

The background of the cover is a photograph of a river winding through a dense forest. The water is dark and reflects the surrounding trees. In the lower right, a small boat with three people is visible. The text is overlaid on the upper left portion of the image.

the  
**ELKS**  
magazine  
JULY 1979

**Police Pursuit Risks**

**GLAUCOMA:  
The Thief Of Sight**

**Suwannee River Fever**



# The World's Most Comfortable Shoe!

The Famous  
**CosmoPedic™**

Not \$50

Not \$25

Here Only

# \$14.99

## Genuine Leather Smooth or Sueded

NOW! BLISSFUL COMFORT MORNING TO NIGHT! The closest thing to going barefoot! Handsomely-styled CosmoPedic shoes are the ultimate in comfort... and quality-crafted with features you'd expect to find in a \$50 or \$25 shoe! Luxurious genuine leather uppers in deer-tanned smooth or sueded leather are incredibly soft, yet amazingly shape-holding. The unique CosmoPedic arch support assures comfort thru long hours of standing or walking. A stitched collar prevents annoying chafing around the ankles. And for that walking-on-air feeling... cushioned insoles and crepe soles pamper your feet from heel to toe! In Tan or Black smooth leather; Brown or Sand sueded leather... just \$14.99!



Tan Smooth  
Leather

for Men and Women

**MEN'S SIZES**  
8½, 7, 7½, 8, 8½, 9, 9½, 10,  
10½, 11, 11½, 12, also 13  
WIDTHS: C, D, E, EE, EEE

**WOMEN'S SIZES**  
5, 5½, 6, 6½, 7, 7½,  
8, 8½, 9, 9½, 10; ALSO 11  
WIDTHS B, C, D, E, EE, EEE

**FAMOUS 14 DAY COSMOPEDIC GUARANTEE**  
Latest fashions, finest quality, great value—accurately described and promptly shipped.  
If these CosmoPedic shoes are not the most comfortable, the finest quality pair of shoes you've ever owned, simply return them within 14 days for a full refund of purchase price, no questions asked. Now that's a guarantee in writing.

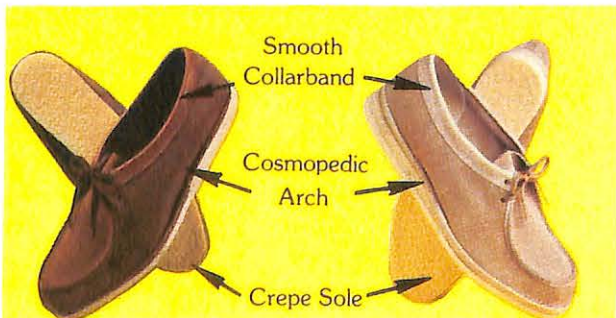

Brown Sueded Leather

Sand Sueded Leather



**OLD VILLAGE SHOP**

Hanover, Pa. 17331

**SATISFACTION GUARANTEED OR MONEY BACK**  
**OLD VILLAGE SHOP Dept. VM-3842 340 Poplar Street, Hanover, Pa. 17331**  
 Sure, I'll try the world's most comfortable shoes. Please send me:

**MEN'S SHOE** \_\_\_\_\_ prs. Men's Tan Leather (M242578B) Size \_\_\_\_\_ Width \_\_\_\_\_  
 \_\_\_\_\_ prs. Men's Black Leather (M236802B) Size \_\_\_\_\_ Width \_\_\_\_\_  
 \_\_\_\_\_ prs. Men's Brown Sueded (M242586B) Size \_\_\_\_\_ Width \_\_\_\_\_  
 \_\_\_\_\_ prs. Men's Sand Sueded Leather (M233361B) Size \_\_\_\_\_ Width \_\_\_\_\_

**WOMEN'S SHOE** \_\_\_\_\_ prs. Women's Tan Leather (M203562B) Size \_\_\_\_\_ Width \_\_\_\_\_  
 \_\_\_\_\_ prs. Women's Black Leather (M203687B) Size \_\_\_\_\_ Width \_\_\_\_\_  
 \_\_\_\_\_ prs. Women's White Leather (M223693B) Size \_\_\_\_\_ Width \_\_\_\_\_  
 \_\_\_\_\_ prs. Women's Brown Sueded (M223784B) Size \_\_\_\_\_ Width \_\_\_\_\_

for just \$14.99 pr., plus \$2.25 per pr. postage and handling.  
**SAVE MORE! Order TWO pair for just \$28.99 plus \$4.00 postage and handling.**

**CHARGE**  American Express  Carte Blanche  Master Charge  
 VISA/BankAmericard  Diners' Club  Interbank # \_\_\_\_\_

Enclosed is \_\_\_\_\_  
 Acc't # \_\_\_\_\_ Date Expires \_\_\_\_\_  
 NAME \_\_\_\_\_ (please print)  
 ADDRESS \_\_\_\_\_  
 CITY \_\_\_\_\_ STATE \_\_\_\_\_ ZIP \_\_\_\_\_



(We need your opinion)

# A system with remote for less than the other people charge for just a telephone answering machine

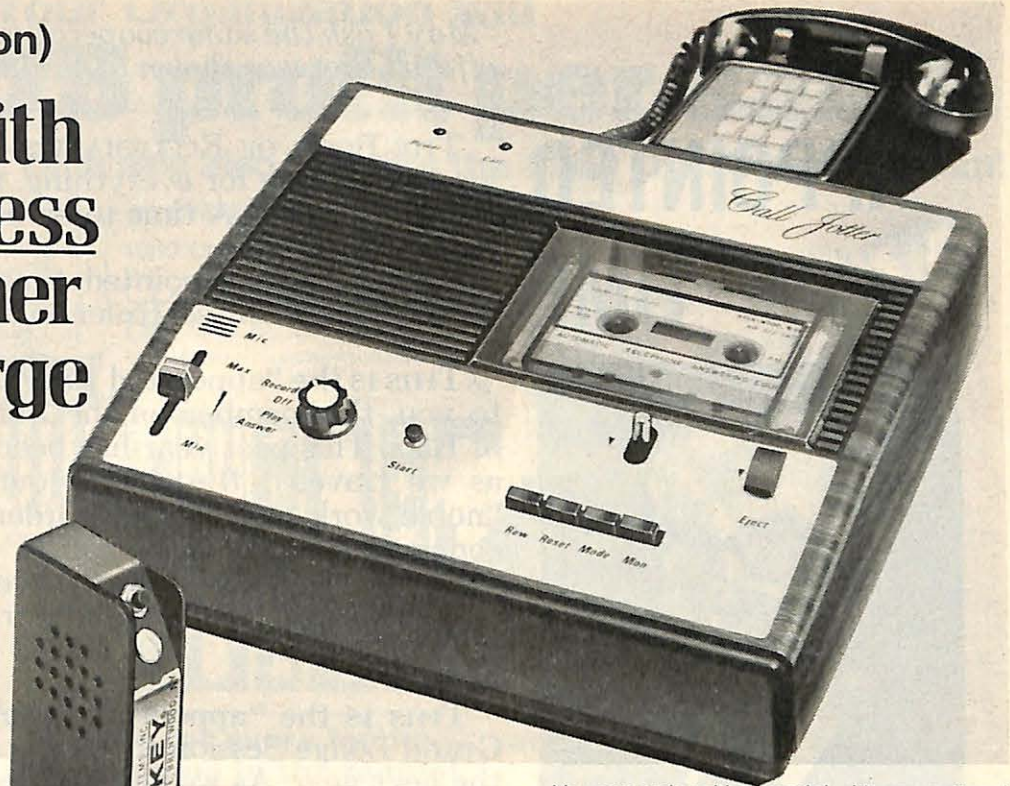

This ad's a test. A kind of consumer survey. With a special Free Offer. To see if the low price of the new Call Jotter remote telephone answering system can turn one of the biggest selling business items into one that's successful with consumers, too.

Ordinarily, information like this comes from a consumer panel. Focus groups. But the manufacturer wasn't about to commit for the enormous sum required based on talk. He wanted facts. And came to us, as one of the largest mail merchandisers, for help. Because orders are facts he could act on.

## Quality Features

For our part, we tested the Call Jotter thoroughly. And can tell you it's exceptionally well made. (It has to be to get our guarantee.) With solid state, microprocessor technology and plug-in simplicity. It's F.C.C. approved. And delivers the freedom and convenience you get with systems selling for \$299.95—which is the going price, as you know, for remote telephone answering machines.

One thing we did tell the manufacturer: something extra should be given to those who participate in this test. He agreed. So, you'll receive with your order a FREE professionally recorded tape that answers and records 30 messages... a FREE blank tape for recording your own messages or for when you're using the machine as a cassette recorder and player... plus a FREE adapter for connecting the Call Jotter to your telephone jack.

## An Extraordinary Convenience

Now, we ask you, how much would it be worth to you, to your wife, even your teen-age children to never miss or worry about a phone call again? And to get your messages without having to wait until you get home—from any phone, anywhere in the world. Resetting the machine to take 30 more messages by touching a button on the Tele-Key remote control.

Of course, you'll use your Call Jotter to answer the phone when you're working outside and when you're in a part of the house where there's no telephone.

How much would you spend for an answering machine when the phone rings and you're up on a ladder painting the house? It's true—isn't it—the phone always seems to ring at exactly the wrong time. Like the critical moment in your favorite show and whenever you're taking a nap.

Get your message from any phone anywhere in the world.



Think of the time you've spent just waiting for someone who's promised to call. And what value do you place on your privacy... on working without interruption?

Because your Call Jotter has a monitoring system that lets you listen without answering, you can go back to what you were doing the instant you know it's a nuisance call or for someone who's out of the house. Naturally, you can take any call that's important.

## Two For The Price of One

For additional value, Call Jotter works with a single cassette, like a pocket recorder or dictating machine, so you'll use it to listen to your favorite tapes and for recording your own tapes, for dictating letters and memos to be transcribed at the office.

## Save \$130.00!

You'll use your Call Jotter, then, when you're away—whether it's running to the corner store or spending a month in Europe.

Still—we agree, you probably wouldn't want to spend \$299.95 for something that isn't business related. With Call Jotter, though, you save \$130.00! And that's a different story.

At **\$169.95** (plus \$4.35 shipping and handling) Call Jotter's the lowest priced remote telephone answering machine you can get. (Without the remote, it's even less, only \$99.95 plus \$4.35 shipping and handling.)

Now, we invite you to discover the convenience and freedom it brings—especially if you're an active family—without risking one cent.

You can order either model with any national credit card simply by calling the toll free number below at any time. If you prefer, send your check to Douglas Dunhill at the address below. (Illinois residents are required to add the sales tax.)

**Call 800-621-5554**

Illinois Residents Call 800-972-5858  
In operation 24 hours, 7 days a week

Remember, the low, down-to-earth price includes the Tele-Key remote control and the two FREE tapes plus the FREE adapter that fits your telephone jack. (If you don't have a phone on a jack, the telephone company will install one for a modest, one time charge when your system arrives.)

## You Must Be Satisfied

Use your Call Jotter for 30 days. If you're not completely satisfied return it to us for a complete refund, no questions asked. Simply use the carton it comes in and follow the simple procedure in the directions we send you.

If this test is successful, the manufacturer will go into full production and you'll be seeing the unit in stores everywhere in six to nine months. You'll have played a part in this success—for which we thank you. Meanwhile, we'll be filling orders while we can from the supply on hand.

- Approved for connection in accordance with telephone company filed F.C.C. regulations
- Uses standard 60-minute cassettes
- Plugs into any phone on a jack with adapter supplied free
- Dynamic microphone, full fidelity speaker, push-button tape controls, call light, recorder-player operates on standard A.C. current
- Tele-Key complete with 9V battery for remote control from any phone anywhere in the world (2" x 3" x 1" — 4 oz.)
- Hi-fi styling. Black and walnut color. Just 9½" x 10½" x 2¾"

The convenience and freedom you want... At the price you've been waiting for.

**Douglas Dunhill**  
INC. AFFORDABLE QUALITY

Dept. 50-3777  
Ten Douglas Dunhill Drive, Oak Forest, IL 60452  
© Douglas Dunhill Inc. 1979



*"May I ask the same cooperation with your new officers that was shown to me during this past year."*

# APPOINTED TIME



A  
MESSAGE  
FROM THE  
GRAND  
EXALTED RULER

THE BOOK OF ECCLESIASTES (3:1-2) tells us: "There is an appointed time for everything, and a time for every affair under the heavens. A time to be born and a time to die . . . ."

THIS IS the "appointed time" for me to bring my year as your Grand Exalted Ruler to an end.

THIS IS the "appointed time" for me to express my gratitude to you, the members of the Benevolent and Protective Order of Elks. This past year has been a busy one for Ginny and me as we traveled throughout our great country observing the "noble work to which this Order is dedicated." The warm and generous spirit of fraternalism that greeted us on every stop during our travels made this year one of great personal satisfaction for us and increased our pride in being associated with Elkdom.

THIS IS the "appointed time" for our Order to convene in Grand Lodge Session to elect a slate of officers to guide us for the next year. As we gather "deep in the heart of Texas," may I ask the same cooperation with your new officers that was shown to me during this past year.

EVERY END is but the beginning of something new. One administration gives way to another. But an administration is only as strong as its members make it. It is my prayer at this "appointed time" that the continued commitment to **effort** and **enthusiasm** that was so evident last year will lead us on to be bigger and better Elks in the year ahead.

AS STATED ABOVE, there is "a time to be born and a time to die." The time in between is what we have to work with as we move ahead. May that time be used wisely and well as we grow together in charity, justice, brotherly love and fidelity.

THANK YOU for this past year, and may God be with you always.

A handwritten signature in cursive script that reads "Leonard J. Bristol".

Leonard J. Bristol



# Your Organization will earn \$1.75 profit per sale!

Easier to sell . . . because each sale also benefits the 1980 U.S. Olympic Team!

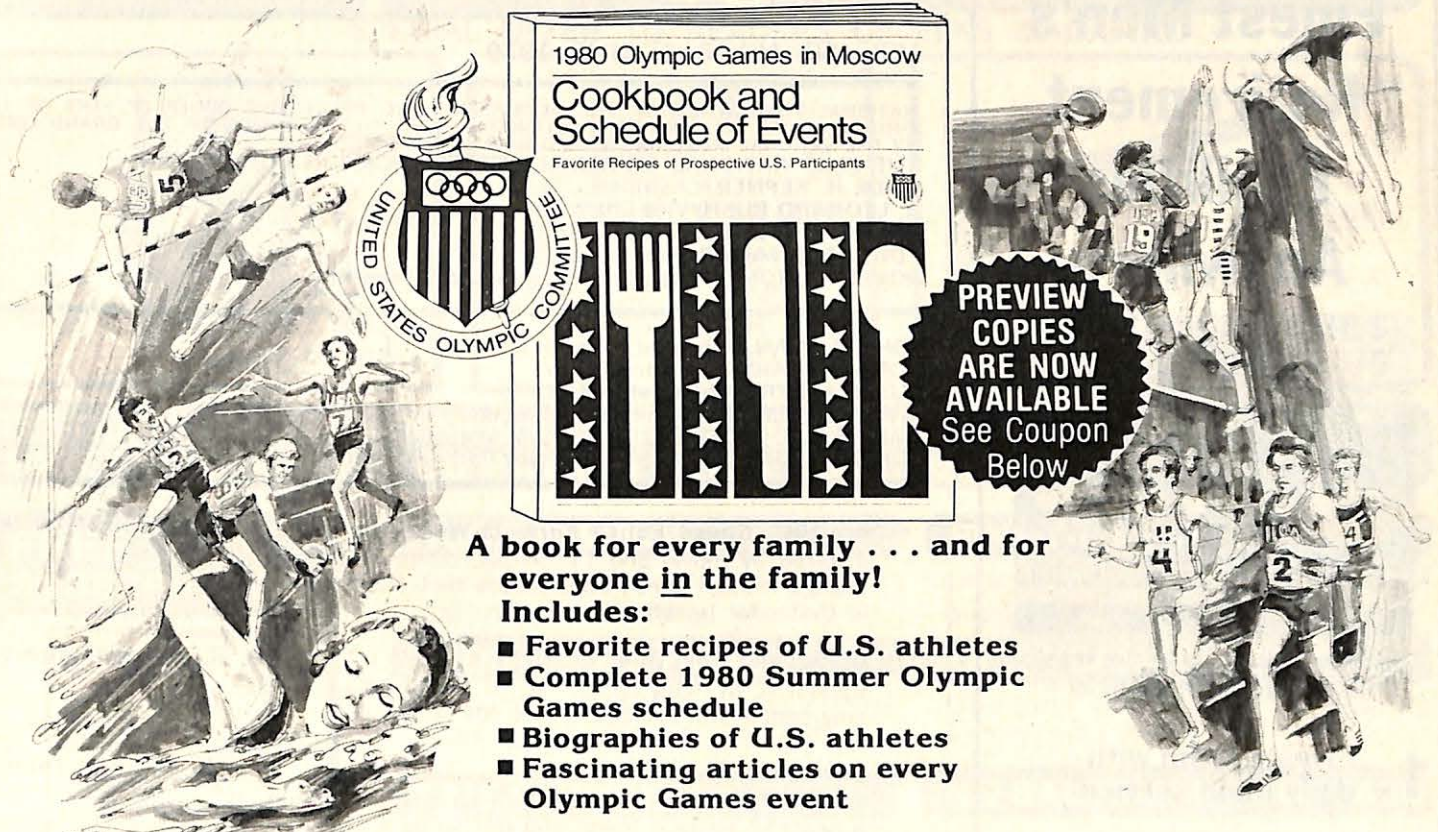

**A book for every family . . . and for everyone in the family!**  
**Includes:**

- Favorite recipes of U.S. athletes
- Complete 1980 Summer Olympic Games schedule
- Biographies of U.S. athletes
- Fascinating articles on every Olympic Games event

**Sell the timely new book published especially for fund-raising organizations like yours!**

It's a natural! You take advantage of the tremendous popular interest in the 1980 Olympic Games and in America's athletes—so you can generate additional funds for your organization.

**The 1980 Olympic Games in Moscow Cookbook and Schedule of Events** is really three books in one: an exciting preview of the 1980 Olympic Games in Moscow . . . a permanent souvenir of the Games . . . and a cookbook like no other! Over one hundred seventy top American athletes, such as Kurt Thomas, Wendy Knudson, and Marty Liquori, expected to represent us in the Olympics, contributed their favorite recipes, over 350 in all—an amazing variety. The book also includes a complete day-by-day Olympic Games schedule . . . informative background articles on the Olympic Games and on each individual sport . . . plus biographies of prospective members of the U.S. Olympic Team.

**Unique sales features mean greater profits for you!**

Any household where there's an interest in sports or cooking—or in helping your organization—is a prime prospect to buy this book from your members. But here's the real clincher to boost your sales: a portion of the proceeds from each book sold will be used to help support U.S. participation in the Olympic games! Of course your organization keeps the entire difference of \$1.75 between your low cost for the book (\$3.25) and the \$5.00 selling price. The donation to the U.S. Olympic Committee will be made directly by Wm. C. Brown Company, one of America's most respected educational publishers.

**Here's what you earn if each member makes as few as 12 sales:**

If you have	and sell	you earn
20 members	12 ea.	\$ 420
30 members	12 ea.	\$ 630
70 members	12 ea.	\$1,470

**Order now! Pay only for what you sell!**

Be one of the very first organizations to benefit from this totally new concept in fund-raising! Along with your books, you will receive plastic carry bags and color sheets with persuasive sales messages. You have a full 45 days after receipt of the books to pay for the ones you sell and to return any unsold merchandise. See the coupon below for details of terms.

All eyes will be on the 1980 Olympic Games . . . all America will be rooting for our nation's athletes as they try for new highs. So your organization is sure to reach its own new high in profits! Act today!

**wcb / WM. C. BROWN COMPANY PUBLISHERS**  
Olympic Project • 2460 Kerper Blvd. • Dubuque, IA 52001

- Please send us \_\_\_ cases of The 1980 Olympic Games in Moscow Cookbook and Schedule of Events (minimum order: 2 cases). We understand the books are packed 48 to a case and sell at \$5.00 each, our cost is \$3.25 per book, a portion of which will be donated by Wm. C. Brown Company to the U.S. Olympic Committee. Our profit per case: \$84.00.
- Please send additional information and a preview copy of the book. We have enclosed \$3.25 plus \$1 for postage and handling. Call toll-free 800-553-4856, ext. 805 for inquiries.

Pay only for the cases you sell. Payment due within 45 days of receipt of merchandise. Any *unopened* cases containing saleable merchandise may be returned within 45 days (\$1 reinspection charge per case). Freight charges are prepaid, billed on the invoice. Extra *free* books will be sent completely covering the shipping cost.

My name \_\_\_\_\_ Title \_\_\_\_\_  
 Address \_\_\_\_\_ Phone ( ) \_\_\_\_\_  
 City \_\_\_\_\_ State \_\_\_\_\_ Zip \_\_\_\_\_  
 Name of organization \_\_\_\_\_ No. of members \_\_\_\_\_  
 Address \_\_\_\_\_

Important: Please have delivery made to business address of one of your members, if possible. This avoids extra home delivery charges, for which Wm. C. Brown Company cannot be responsible.

Shipping address (if different from above) \_\_\_\_\_  
 Signature of adult who will be responsible for payment \_\_\_\_\_

ELJLY





# One Of The Finest Men's Retirement Facilities Anywhere

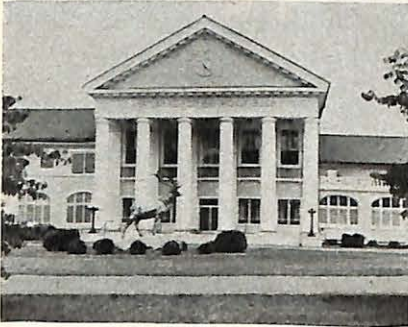

If you have been an Elk for five years, and ambulatory, you are eligible for—

1. Private room with daily maid service
2. Three nutritious meals daily
3. Excellent hospital facilities
4. Free monthly laundry and dry cleaning
5. Free haircut monthly
6. The finest recreation facilities
7. Weekly recreational and shopping excursion

A few vacancies still exist, but the Home is filling up fast.

For full details write:

**DORAL E. IRVIN**  
Executive Director  
Dept. 779  
The Elks National Home  
Bedford, Virginia 24523

VOL. 58, NO. 2 / JULY, 1979

NATIONAL PUBLICATION OF THE BENEVOLENT AND PROTECTIVE ORDER OF ELKS OF THE UNITED STATES OF AMERICA. PUBLISHED UNDER THE DIRECTION OF THE GRAND LODGE BY THE NATIONAL MEMORIAL AND PUBLICATION COMMISSION.  
THE ELKS NATIONAL MEMORIAL AND PUBLICATION COMMISSION  
**WADE H. KEPNER/Chairman**  
**R. LEONARD BUSH/Vice-Chairman**  
**RAYMOND C. DOBSON/Secretary**  
**EDWARD W. McCABE/Treasurer**  
**ROBERT E. BONEY/Asst. Secretary and Asst. Treasurer**

**JOHN R. RYAN/Publisher/General Manager**  
**DONALD STAHL/Managing Editor**  
**SUSAN ALBERT/Fraternal News Editor**  
**SHIRLEY STERLING/Advertising Manager**  
**MALCOLM B. CROFFORD/Circulation Manager**  
**EDITORIAL OFFICES, 425 W. Diversey Parkway, Chicago, IL 60614**

- |    |  |                        |
|----|--|------------------------|
| 6  | <b>Are High Speed Police Pursuits Worth the Risks?</b><br>Inspired by movie and TV heroes, police officers engage in high speed auto chases that often result in bystander fatalities. | Wayne T. Walker        |
| 12 | <b>Glaucoma: The Thief of Sight</b><br>Blindness, in many cases, can be prevented—if only people will act before it is too late.   | G. R. von Kronenberger |
| 23 | <b>Suwannee River Fever</b><br>Mention the Suwannee River and we begin to dream of a peaceful solitude found and lost so long ago.   | Bill Thomas            |

#### Departments

- |                                     |   |
|-------------------------------------|---|
| 2 Message                           | 19 News of the Lodges                         |
| 10 Visits of Leonard J. Bristol     | 25 Elks National Foundation/<br>Joy of Giving |
| 11 You and Retirement: Sales        | 26 Major Projects: SD/OK                      |
| 14 Letters                          | 28 Travel: Caribbean                          |
| 15 Medicine and You: Cataracts      | 34 Elks Family Shopper                        |
| 16 Elks National Service Commission |   |
| 18 It's Your Business: Economy      |   |

Cover: Suwannee River

Bill Thomas

#### ADVERTISING OFFICES



CHICAGO 60614 425 W. Diversey Parkway (312) 528-4500  
NEW YORK 10017 50 East 42nd (212) 682-2810

#### THE ELKS MAGAZINE, Circulation Dept., 425 Diversey Parkway, Chicago, IL 60614

**MEMBERS:** Changes of address should be made through your lodge Secretary. Give him advance notice of at least 30 days. Remember that the day you write, your next copy is already in the mails. Before you move, file your new address at the post office to have mail forwarded. In writing to us regarding an address change, please give: Full name, lodge number, membership number, address to which copy is being mailed, and complete new address. Attach label from recent issue if available. Please show ZIP Code numbers in both old and new address.

THE ELKS MAGAZINE, Volume 58, No. 2, July, 1979 (ISSN 0013-6263). Published monthly at 425 W. Diversey Pkwy., Chicago, IL 60614 by the Benevolent and Protective Order of Elks of the United States of America. Second class postage paid at Chicago, IL, and at additional mailing office. Acceptance for mailing at special rate of postage provided for in Section 1103, Act of October 3, 1917, authorized May 20, 1922. Single copy price is 25 cents. Subscription price in the United States and its Possessions, for Elks, \$1.25 a year, for non-Elks, \$2.50 a year; for Canadian and Foreign postage, add \$1.50 a year. Subscriptions are payable in advance. Manuscripts must be typewritten and accompanied by sufficient postage for their return via first class mail. They will be handled with care but this magazine assumes no responsibility for their safety.

The word, **Elks**, is a registered trademark of The Benevolent and Protective Order of Elks of the United States of America. Copyright, 1979, by the Benevolent and Protective Order of Elks of the United States of America



**FREE TRIAL**  
BEFORE YOU BUY

# HEARING AIDS

UP TO **50% OFF** COMPARABLE AIDS

SPECIAL OFFER TO READERS OF ELKS MAGAZINE

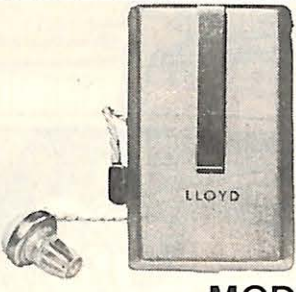

**\$89<sup>50</sup>**  
**BODY AIDS**  
**MODEL 59B**



**\$189<sup>50</sup>**  
**BEHIND THE EAR AIDS**  
**MODEL 270**

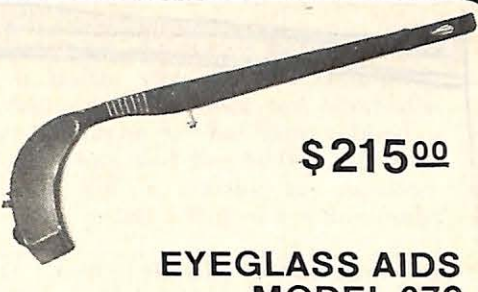

**\$215<sup>00</sup>**  
**EYEGLOSS AIDS**  
**MODEL 670**

**GET QUALITY HEARING AIDS AT AMAZINGLY LOW PRICES BECAUSE WE SELL DIRECT BY MAIL • YOU PAY NO DEALER MARK-UPS OR COMMISSIONS.**

**FREE SUBSCRIPTION**

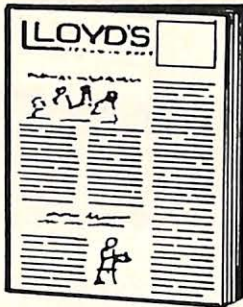

**LLOYD'S LISTENING POST**  
Here's your chance to get this fine Senior Citizens paper absolutely FREE.. It's full of news, articles, and interesting material. You don't have to buy a Hearing Aid or anything else. "Listening Post" is yours for the asking.

**LOW-LOW PRICES ON HEARING AID BATTERIES**

- MERCURY BATTERIES  
13      12 for \$6.00  
41      12 for \$6.00  
312     12 for \$6.00  
401     6 for \$6.00  
675     12 for \$7.00
- SILVER OXIDE BATTERIES  
MS-13   12 for \$6.50  
MS-41   12 for \$6.50  
MS-312 12 for \$6.50  
MS-76   12 for \$7.50

ORDER IN QUANTITIES LISTED

**HUGE SAVINGS**

Buy direct—Eliminate dealer mark-ups and commissions.

**30 DAY FREE TRIAL**

We send you the Aid of your choice —FREE TRIAL—No obligation.

**TIME PAYMENTS**

Time payments arranged after you are satisfied with your choice.

**FINE QUALITY**

One of the Largest Selections of quality Aids to choose from.

**ONE YEAR WARRANTY**

One year warranty on all Hearing Aids from LLOYDS.

**NO SALESMAN WILL CALL**

We promise no salesman will ever call on you.

**OUR TRUST THE CUSTOMER PLAN . . .** has been a resounding success for over 15 years. We've sent thousands of Hearing Aids to customers in all 50 states, never asking for a deposit or down payment. Our files have thousands of letters from satisfied customers. Want us to prove it? Just write us or send coupon on this page.

**LLOYD HEARING AID CORP. 128 Kishwaukee St. P.O. Box 1645 Rockford, Ill. 61110 Dept. EM**

Please send me FREE Literature and Low Prices on all types of Hearing Aids and a FREE Subscription to LLOYD'S LISTENING POST (Senior Citizens Paper)

**REMEMBER, WE PROMISE NO SALESMAN WILL CALL.**

NAME \_\_\_\_\_  
ADDRESS \_\_\_\_\_  
CITY \_\_\_\_\_ STATE \_\_\_\_\_ ZIP CODE \_\_\_\_\_

**WE EVEN PAY THE POSTAGE . . .** fill in coupon. Just tape or paste this Postage-Paid label to the front of any envelope. No further postage or addressing is needed.

Dept. EM

**BUSINESS REPLY LABEL**  
FIRST CLASS PERMIT No. 1891, ROCKFORD, ILLINOIS

POSTAGE WILL BE PAID BY ADDRESSEE

**LLOYD Hearing Aid Corporation**  
**128 Kishwaukee St.**  
**P.O. Box 1645**  
**Rockford, Ill. 61110**

**NO POSTAGE NECESSARY IF MAILED IN THE UNITED STATES**

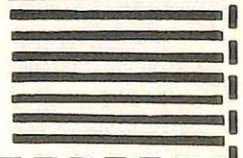



# Are high speed police pursuits worth the risks?

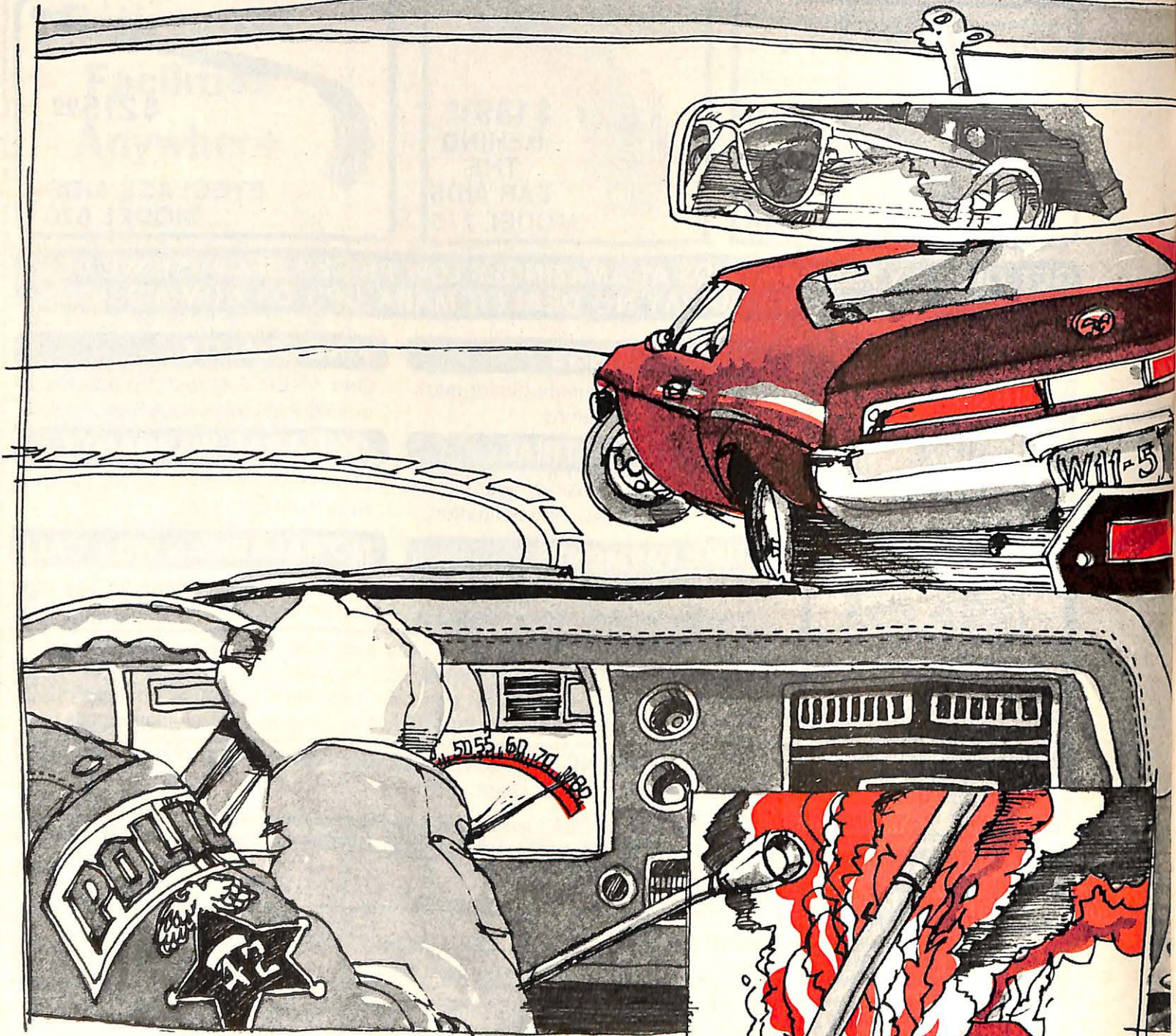

by Wayne T. Walker

## ■ "10-80... chase in progress."

About 4:15 p.m. police officer Mark Slocum spotted the black and gold Pontiac Trans Am speeding through Claycomo, Missouri. The car was a dead ringer for the one driven by Burt Reynolds in the chase scene from the movie *Smokey and the Bandit*.

Slocum recalled, "It was exactly the same kind of car, but I wasn't thinking about it then."

Once he became involved, Slocum was determined to stop the Trans Am and pursued the car through Claycomo, Pleasant Valley and Liberty. Finally, his quarry turned off on Hughes Road, a gravel road that winds

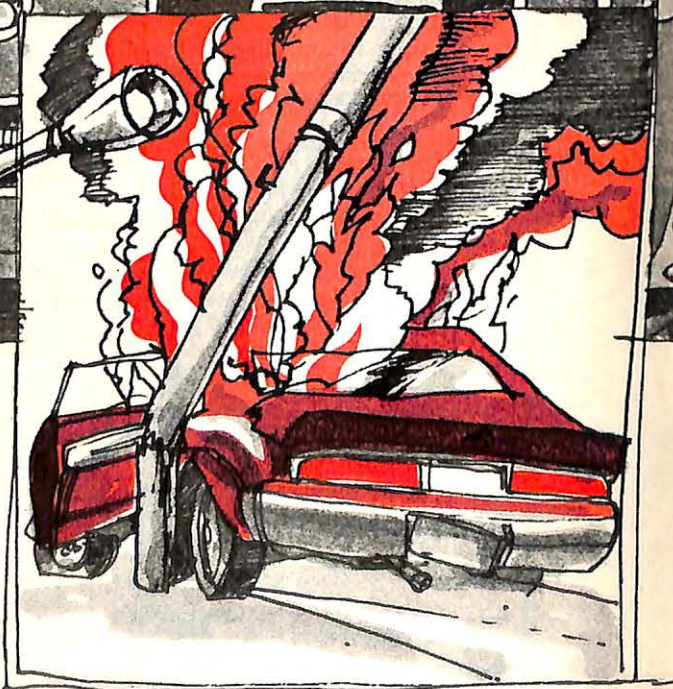



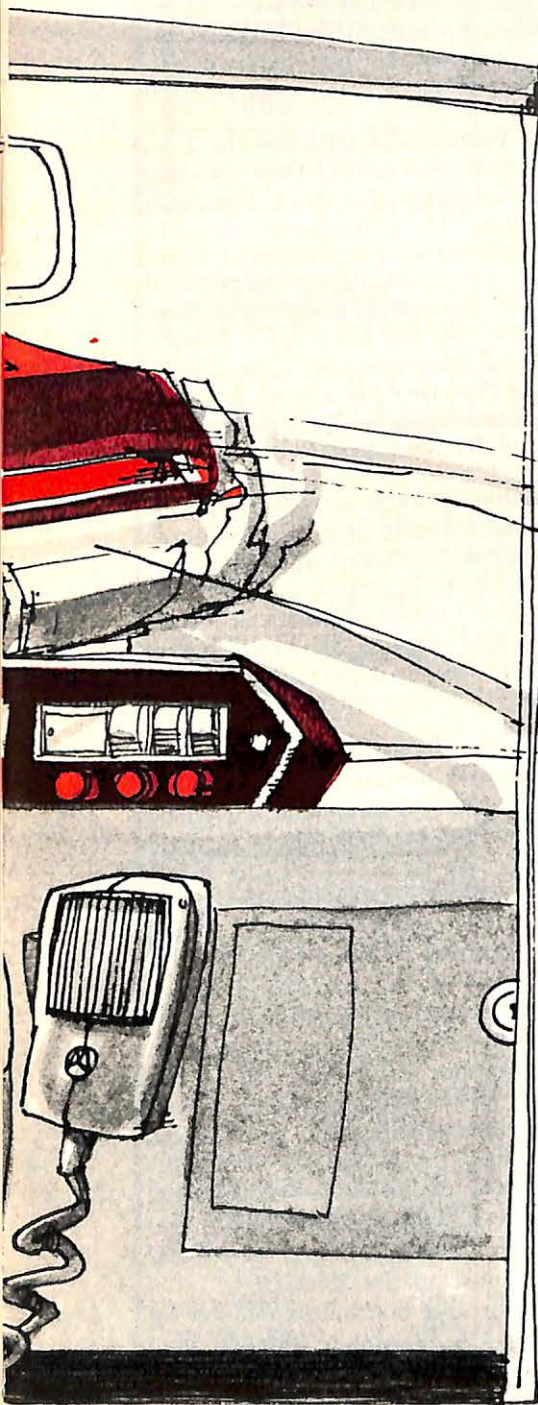

south to the Birmingham Bottoms of North Kansas City.

"We were going up to 90 miles per hour on the gravel road," Slocum said. "I couldn't stay too close because of the gravel and the dust, but I could keep him in sight."

When the road came to a dead end, Slocum thought he had the driver cornered. But like Reynolds in the movie chase, the driver jumped his car across the ditch and continued through a corn field.

"When he went into the corn field I really started thinking about the similarities to the movie," Slocum said, after arresting the 19-year-old youth who was driving the car. He was uninjured, but his 17-year-old girl friend had to be taken to a North Kansas City hospital for treatment.

Fortunately, no one was seriously injured, and Slocum got his man.

Numerous movie producers have intensified the action in their films by high speed chase scenes, with fast-tempo bluegrass music in the background. On film, it is regarded as exciting and hilarious. But what about the real pursuits on our congested highways and streets?

Approximately 6,000 to 8,000 pursuits result in crashes each year, according to a study completed for the National Highway Traffic Safety Administration (NHTSA). The study reported that 300 to 400 persons are killed in these crashes, with 2,500 to 5,000 being injured.

Lloyd Sellers, chief of staff of the California Highway Patrol, is a staunch defender of pursuit. He sees it as a major factor in California's outstanding safety record. The 3.2 deaths per 100 million miles ranks California fourth best in the nation.

Yet, there can be no doubt that turning an adrenaline-pumping police officer loose in a two-ton cruiser to chase someone at high speeds greatly increases the risk of injury to everyone on the road.

Despite this logic, most officers will argue that the high speed pursuit is the quickest way to get dangerous drivers stopped and off the road. They will also insist that it's the best deterrent against drivers' trying to escape arrest or speeding citations. If a driver knows he won't be chased, he'll run for it.

Sometimes the driver being pursued for a traffic violation has committed another crime he does not want disclosed. Maybe he has just robbed a jewelry store and has \$6,000 worth of jewelry and is making his getaway. Perhaps he has a bag of cocaine under the seat.

In Grafton, Illinois, two escaped convicts in a stolen car were spotted running a stop sign by city police and were soon being pursued by the Grafton officers, as well as sheriff's deputies from Jersey and Madison counties. Needles on speedometers began hovering close to the 100 mph mark.

Near Godfrey, IL, the stolen car with the escapees roared into a busy highway intersection and struck an automobile broadside. The gasoline tank exploded instantly and a 28-year-old mother was burned to death.

One of the deputy sheriffs commented: "We used the best judgement we could under the circumstances. These were dangerous men and needed to be apprehended."

During recent months Kansas City, Kansas, has been plagued by a series of incidents that began as police actions but ended in death or serious injury to a hapless bystander or passerby.

About 10:30 p.m. one night in late October, Rose M. Daily, 36-year-old mother of seven and wife of an army major—was traveling east on Parallel, headed for her job at Providence-St. Margaret Health Center. At the same time, a car driven by a 21-year-old youth was swerving around a corner at a high rate of speed at 82nd and State.

A Kansas City policeman saw him and gave chase. By the time the pursuit was westbound on Parallel, the speedometers of the police car and the 1971 Mustang were pushing 100 mph. Suddenly, the youth flipped off his headlights. At this time, the Mustang was pulling away from his pursuer.

It was a highly dangerous situation. This was a residential area; there were four lanes of traffic; the Mustang was hitting over 90 miles per hour with its headlights off. The field supervisor came on the police radio and told the pursuing officer to terminate the chase immediately.

But before the chase terminated, the youth sped through a four-way stop, tried "to split the center lane" and pass



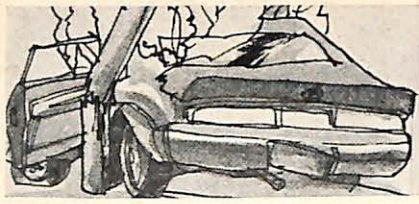

a car in front of him. The high-balling Mustang rammed head on into Mrs. Daily's car.

"I just don't understand," said Major Charles T. Daily, "how they can give chase at 100 miles per hour through a residential neighborhood—and risk an innocent person's life."

The Daily family is bitter over the loss of a wife and mother, while the police officer's loved ones do not understand the pressure and accusations brought about by the officer's attempt to do his duty as he saw it.

More than a decade ago, a study was presented to the American Medical Association in which the foolishness of "hot pursuit" of errant motorists by police was demonstrated.

At that time, the study estimated that 500 Americans were killed each year and more than 1,000 seriously injured in police pursuits of suspected lawbreakers, most of whom turned out to be only minor traffic offenders. The Physicians for Automotive Safety learned that one chase in five led to a traffic fatality, with 10% of the fatalities being among the police involved in the chase. Almost half of the deaths were inflicted upon innocent persons in other automobiles and pedestrians.

The latest study by the NHTSA estimates that there are 250,000 police pursuits each year in the nation. Most of these, they report, end quickly and without incident. It was also brought out that:

- ⊙ More than 90 percent of pursuit cases are triggered by an observation of a traffic violation.

- ⊙ Approximately 15 percent of the offenders were driving without a valid license. About 50 percent had at least one prior license suspension or revocation.

- ⊙ Youthful males with inferior driving records are the most likely to flee from a law officer.

- ⊙ Only three to eight percent of pursuits involve stolen vehicles.

In light of these studies and public pressure, many metropolitan police departments and state agencies have taken a new look at pursuits—either forming new policies or revamping old ones. These policies, in general, limit the number of cars in pursuit to two or three, encourage the use of helicopters, involve a supervisor with making on-going decisions, and set down guidelines as to when an officer is justified in aborting a chase.

Yet, as in police shooting cases, the formulated operating procedures are abstract in the actual pursuit, when decisions must be instantaneous, almost instinctive. The pursuing officers must continually question whether the seriousness of the violation warrants continuation of the pursuit.

During July, 1978, an order was issued to the St. Louis Police Department requiring that sergeants evaluate a chase when it begins. As a result, 20 of the 50 chases conducted up to October 25th were halted within seconds by the sergeants. Most of these were pursuits of traffic violators.

Nevertheless, Lt. Col. William E. Brown, who issued the order, stated: "You not only have to evaluate each chase against the loss of life, but also the risk of damaging expensive patrol cars."

"When you realize that each of these police cars is worth \$10,000, once you figure in the cost of the expensive equipment, you certainly don't want them damaged or destroyed over a traffic violation, such as by using them for a roadblock to stop some teenager for speeding."

As an example of the latter, three teenagers in a stolen automobile led an Illinois state trooper on a wild ride. The trooper, William Haley, radioed the St. Louis police and notified them of the chase that was headed down Interstate 44 into the city. On the chance they might turn off at the 12th Street exit south of downtown, a St. Louis police car was pulled across the exit as a roadblock.

With a squealing of tires, the stolen car roared off the interstate and around the exit. Too late, they saw the police car. Sliding 117 feet, they smashed into the almost new patrol car.

Another major problem in police pursuits, even though many municipalities have attempted to curb it, is the caravan of police vehicles in a chase.

On the Sunday night of October 2, 1978, a police officer in Leawood, a suburb of Kansas City, Kansas, tried to stop a red station wagon after it ran a stop light. The station wagon sped to Ward Parkway, through the Country Club Plaza area and south on Brookside while police cars from Prairie Village and Kansas City joined the chase. A Kansas City police helicopter flying overhead kept track of the station wagon as the officers on the ground alternately neared and then fell away.

By 9:20, the speeding motorcade had looped back to Ward Parkway and was headed southeast to the point where the parkway ends at Wornall Road.

Officers Bill Aguirre and Bob Robnett were standing just south of that intersection, waiting to direct traffic

out of the Beth Shalom Synagogue. They were startled to see the station wagon slow down for the curve onto Wornall, then speed up—straight at them.

Each officer stood squarely in the middle of one south bound lane and pointed his gun at the station wagon. They hoped desperately that the driver would stop. Screeching and weaving, he did. When he got out and placed his hands on top of the car, the two officers discovered it was a 15-year-old boy.

Corp. Patrick McCarthy, of the Leawood police, was one of those chasing the station wagon during the high speed chase. He said, "I was afraid to look down at the speedometer. I never did look. Boy, all those flashing red lights and sirens. It looked like the 'Sugarland Express.'"

"I don't think there is ever a need for more than two police cars pursuing a suspected criminal," said Lt. Col. Brown, of the St. Louis Police Department.

He cited a Highway 40 chase in 1970 as an example of one in their area that involved far more men than was needed. About 30 city and county policemen in 25 police vehicles chased two men in and around St. Louis before they were finally apprehended. The two men were charged with traffic violations.

Many officials across the nation contend that the authority of their law enforcement officers to pursue law violators is the crux of their efforts to deter crime.

"What choice do you have," asked a Houston, TX, police officer, "if a lawbreaker is going to be apprehended?"

Officials explain that an officer is recruited, examined, and trained on the basis of judgement and perception of problems. After he is put out in the field the officer is largely on his own, and his superiors hope he will use the sound judgement it was felt he had.

However, the fact does remain that pursuits result in an unacceptable number of casualties and, therefore, the tactic itself must be questioned.

Although the normal population of Anaheim, CA, is about 200,000, over 13 million visit the city every year. This is due to Disneyland, the Angels' baseball team and stadium, and the numerous conventions held there in its various convention centers every year. It is always a highly active and energetic city.

During the first three months of 1978, the Anaheim Police Department appeared to be carrying on a taxpayer-sponsored demolition derby with their fleet of 38 marked cruisers. There were 22 police vehicles involved in a total

*(Continued on page 17)*



**SPECIAL OFFER**

from Bob Lee  
400 UNIT

**VITAMINE**  
CAPSULES

LIMIT  
ONE OF ANY SIZE TO  
A FAMILY

COMPARE ANYWHERE

- 100 for 1.39
- 500 for 6.88
- 1000 for 12.99

MAIL COUPON WITH ORDER  
B331



Bob Lee

**VITAMINS-BY-MAIL**

Our Low Prices  
Speak for Themselves

**LEE NUTRITION**

290 Main St., Cambridge, Mass. 02142

Upon ordering, we will mail you our latest catalogue with many exciting products that we do not have room to list here including the BOB LEE Newsletter filled with humor, customer comments and today's happenings.

**"Order from Lee and pocket the savings"**

250 mg. CAPSULES THE MOST WANTED POTENCY

**GINSENG** 100 for 2.89  
500 for 12.95

**VITAMIN E**  
CAPSULES

MONEY BACK GUARANTEE—HIGHEST QUALITY

SIZE	100 I.U.	200 I.U.	400 I.U.	1,000 I.U.
100	89¢	1.59	2.76	5.79
500	4.39	7.77	13.59	28.45
1000	7.99	12.49	26.99	50.00

**500 MG. BEE POLLEN tabs**  
AMAZING CONTENT OF NATURAL LIFE—VITAL NUTRIENTS.  
WONDER FOOD OF THE BEE COLONY

100 for 2.22 500 for 7.99

**ARTHRITIS RHEUMATISM PAIN?**

**PUTS PAIN TO SLEEP**



Now blessed, quick temporary relief from the pain of arthritis, bursitis, rheumatism, soreness, stiffness. Just rub Rumal's creamy balm over the affected joints or muscles, and you can feel the pain start lessening in seconds! Begin to sleep peacefully again. If you don't have relief faster than you dreamed possible, we'll refund your money. Send \$3 for 3 1/2 oz. jar or \$5.00 for 7 oz. jar. B331

25 MCG. TABLETS

**SELENIUM**

100 TABLETS **1<sup>19</sup>** 500 for **4<sup>95</sup>**

**NATURAL VITAMIN C**

With Rose Hips Tablets  
AT FANTASTICALLY LOW PRICES

QUANTITY	100 MG.	250 MG.	500 MG.	1000 MG.
100	69¢	95¢	1.39	1.95
500	2.98	4.49	6.59	9.39
1000	5.49	7.99	12.49	17.95

**VITAMINS FOR HAIR CARE**

HIGHEST QUALITY—SAME FORMULA AS HIGH-PRICED NAME BRANDS

**PENNIES-A-DAY PRICES**

100 DAY SUPPLY 3.95 200 DAY SUPPLY 7.49

**BALANCED 50 MG. B-COMPLEX**

**HI-POTENCY "LEE-PLEX 50 MG."**

In 1 cap daily: 50 mg. each of Vit. B1, B2, B6, Niacinamide, Pantothenic Acid, Choline, Inositol; 30 mg. Para-Aminobenzoic Acid; 50 mcg. each of B12, d-Blotin; 100 mcg. Folic Acid.

100 CAPS **2<sup>69</sup>** 500 CAPS **10<sup>99</sup>**

**BREWERS YEAST TABLETS**  
7 1/2 GR.  
250 TABLETS **49¢**  
1000 for 1.69

**VITAMIN A**  
25,000 UNITS  
100 FOR **1<sup>29</sup>**  
500 for 5.00

**HIGH FIBER BRAN TABLETS**  
500 MG.  
100 TABLETS **69¢**  
500 for 2.99

**VITAMINS A & D**  
(5000 A; 400 D)  
100 TABLETS **49¢**  
500 for 1.95

**KELP TABLETS**  
100 TABLETS **35¢**  
1000 for 1.50

**SUPER ORGANIC IRON TABS**  
100 TABLETS **1<sup>29</sup>**  
500 for 4.50

**CHILDREN'S NATURAL CHEWABLE VITAMINS**  
100 TABLETS **89¢**  
500 for 3.99

**Acidophilus CAPSULES**  
100 CAPSULES **1<sup>79</sup>**  
500 for 8.75

**HI-POTENCY STRESS FORMULA**  
(Same Formula as Plus 72. Compare Our Price)

100 TABS **1<sup>95</sup>** 250 TABS **3<sup>89</sup>**

**ALFALFA TABLETS**  
100 TABLETS **39¢**  
500 for 1.59

**GARLIC OIL CAPSULES**  
100 CAPSULES **55¢**  
500 for 2.35

**DOLOMITE TABLETS**  
100 TABLETS **45¢**  
1000 for 1.89

**HERBAL LAXATIVE**  
100 TABLETS **85¢**  
500 for 3.49

**OUR LOW PRICES ON FRUCTOSE**  
2 GRAM TABLETS

100 TABLETS ..... **2<sup>89</sup>**  
200 TABLETS ..... **4<sup>98</sup>**  
500 TABLETS ..... **9<sup>95</sup>**

**LIQUID FRUCTOSE**  
Each bottle contains 120 portions of 3 grams FRUCTOSE... the convenient money-saving form.

1 lb. **1<sup>98</sup>**  
3 Bottles **5<sup>50</sup>**

**FRUCTOSE 3 Gram Packets**

Box of 50 **1<sup>98</sup>** 3 Boxes **5<sup>75</sup>**

**GRANULAR FRUCTOSE**  
8 oz. Bottle ..... **1<sup>98</sup>**

**BONE MEAL TABLETS**  
100 TABLETS **49¢**  
1000 for 3.95

**ZINC 10 MG. TABLETS**  
100 TABLETS **39¢**  
1000 for 3.65

**HERBAL DIURETIC**  
100 TABLETS **1<sup>49</sup>**  
500 for 5.99

**Neutramints (ANTI-ACID) TABLETS**  
100 TABLETS **89¢**  
500 for 3.25

**VIT. B6 50 MG. TABLETS**  
100 TABLETS **65¢**  
500 for 2.95

**DESICCATED LIVER TABLETS**  
7 1/2 Grain  
100 TABLETS **69¢**  
1000 for 3.50

**COD LIVER OIL CAPS**  
100 CAPSULES **88¢**  
500 for 3.99

**19 GR. 1200 MG. HI-POTENCY LECITHIN**  
100 CAPSULES **1<sup>29</sup>**  
500 for 5.79

**595 MG. Potassium GLUCONATE**  
100 TABLETS **99¢**  
500 for 4.50

**CHOLINE 250 MG. TABLETS**  
100 Tablets **1<sup>65</sup>**  
500 for 6.95

**PANTHENOL HAIR THICKENER AND CONDITIONER FOR MEN AND WOMEN**

8 oz. **1<sup>99</sup>**  
3 for **5<sup>00</sup>**

PRICES IN THIS AD GOOD NEXT 30 DAYS

**LEE NUTRITION ORDER FORM**  
Postpaid—Money Back Guarantee

QUANTITY	SIZE	NAME OF PRODUCT	TOTAL PRICE

MAIL YOUR ORDER TO: TOTAL ENCLOSED

Lee Nutrition  
290 MAIN ST.  
CAMBRIDGE, MASS. 02142 B 331

PRINT NAME \_\_\_\_\_

STREET \_\_\_\_\_ APT. \_\_\_\_\_

CITY \_\_\_\_\_

STATE \_\_\_\_\_ ZIP \_\_\_\_\_



# LODGE VISITS

## GRAND EXALTED RULER LEONARD J. BRISTOL



Honored guests of Chaffee, MO, Lodge recently were GER Leonard Bristol (center), Ginny Bristol, and PGER Edward McCabe (right) and his wife, Maggie. The dignitaries attended the state convention, and Brother Bristol dedicated the lodge's new recreation area. ER Daniel Bollinger (left) and his wife, Lynn (second from right), welcomed their guests at a dinner which was served by the local Girl Scouts.

◀ A celebration commemorating the founding of Rensselaer, NY, Lodge took place recently. GER Leonard Bristol (center) was on hand to wish the lodge a happy 20th birthday. Brother Bristol joined PDD Alexander Seney (left), the lodge's first Exalted Ruler, and ER Peter Benko for the dinner affair.



A special guest at Galena, IL, Lodge's 75th anniversary celebration was GER Leonard Bristol (center). A crowd of 500 people attended a dinner held at the lodge followed by a dance held in a nineteenth-century ballroom. On hand to welcome the guests were (front row, from left) H. Foster Sears, chairman of the Board of Grand Trustees, PGER Glenn Miller, SP Fred Sheehan, VP William Leas, and (back row) PSPs Robert Flynn and Wesley Waterhouse.

During Brother Bristol's visit to Lynn, MA, Lodge, he presented an honorary founder's certificate to PER Arthur Gold (right). The occasion was held at Pleasant Valley Country Club in Sulton, MA. PGER Ronald Dunn also witnessed the presentation.



A police-escorted, 20-car caravan brought Ginny and GER Leonard Bristol (third and fourth from left) from the airport to the Hilton Motel in Huntsville, AL, recently. Those who comprised the caravan included (from left) PGER Robert and Mrs. Pruitt, ER Clayton Moneymaker, DDGER W. D. Wood, Mrs. Moneymaker, and SP W. F. Hoover.



# YOU AND RETIREMENT

by Grace W. Weinstein



## PERSON-TO-PERSON SALES

Want to earn some extra money in your spare time? Build toward post-retirement income? Be independent? Direct sales may be your answer. With an honorable history going back to Colonial America and the Yankee Peddler, direct sales now involve some two million Americans selling some \$6 billion worth of merchandise each year.

What kind of products are sold this way? Almost any kind you can name—but the leaders in the field, according to the Direct Selling Association, are cosmetics and personal care items, vacuum cleaners, plastic housewares, home maintenance services, costume jewelry, and reference books. Familiar product names are among them: Avon and Tupperware, Stanley Home Products and World Book Encyclopedia, Amway and Sarah Coventry.

Most direct sales, about 60 percent, are made through a personal visit to a prospective purchaser's home, the traditional door-to-door approach—although the way is often eased through recommendations from satisfied customers. About 15 percent are made at sales parties where goods are touted to a group of prospects, usually friends of the hostess.

Either way, whether you sell one-to-one or at a party, you reap a share of the profits. You may do so by buying the products wholesale and selling them at retail. Or you may do so through a commission—often 25 to 35 percent—on sales. Some companies, such as World Book, will also pay a flat rate for a specific number of demonstrations, whether or not any sales result. Many companies also offer bonus and incentive plans. Top salespeople often move on to managerial positions, where the potential rewards are even greater.

You can sell part-time or full-time. Either way, you have a great deal of flexibility. In direct sales, your time is your own. Your earnings will, however, reflect the time and work you put in, and selling is not necessarily easy. World Book estimates that an effective part-timer should commit himself to at least three sales demonstrations a week, for a total of six to nine hours of work. That's a minimum. Those hours, furthermore, may have to include weekends and evenings if you are to reach your customers when they are at home. And those hours do not include the pre-demonstration work of lining up prospects or the post-

sales time, if you have made a sale, in paperwork.

Many people of all ages, nonetheless, find direct sales a satisfactory route to extra income. A 1975 Harris survey found that direct salespeople enjoy the contact with people as well as the opportunity to work when and as much as they please. The same survey showed that people in general, the public to whom sales efforts are made, rate direct salespeople very highly.

Age is not a barrier to success in direct sales, and retirement is a word that does not apply. There are older individuals, many "retired" from other occupations, working in every line of direct sales. World Book, for example, points with pride to 83-year-old Beth Ramacher,

a former teacher and principal, who has been busily selling encyclopedias in her home state of California for years. For fourteen years, in fact, she has worked six nine-to-five days a week and has sold a minimum of 100 sets per year.

If you decide to give the field a try, you can find direct selling opportunities in the pages of your local newspaper; you can find well-known national companies in the telephone directory; and you can get a list of member companies, and the products they sell, from the Direct Selling Association, 1730 M St., N.W., Washington, DC 20036. Direct selling has had some spots of tarnish on its image, however, as get-rich-quick operators have jumped on the bandwagon, and there are some rules for the wary:

⊙ Find out what, if any, will be your out-of-pocket costs. You shouldn't have to spend more than \$50 for start-up materials. Amway's starter kit is \$15 and World Book's is \$14. Stanley Home Products, another reputable concern (and the originator of the home party plan), charges dealers \$22 for equipment; dealers must also buy a set of products at wholesale prices. Assess all related costs carefully too: Will you have to drive any distance to pick up your merchandise? Will you need to buy bags or catalogs? Will you have to purchase "hostess gifts" for at-home parties?

Watch out for "pyramid" schemes, where you are asked to make a major  
*(Continued on page 27)*

## "Satoh cuts my costs while it cuts my lawn. That satisfies me."



Satoh satisfaction means getting the most tractor for your money. Satoh's line of Diesel tractors give you more fuel economy plus greater productivity. They're smooth-running, quiet and easy to handle with a professional range of power ratios and implement capabilities for tackling any job.

Nothing smaller can match Satoh versatility. And nothing larger can match Satoh economy.

That's why nothing else can satisfy me.

## Satoh. Satisfaction!

Get it at your **SATOH** tractor dealer.  
P.O. Box 5020, New York, N.Y. 10022



# GLAUCOMA:

If we had to depend upon mechanical devices to do our seeing for us, the chances are we'd be blacked out half the time while they were in the shop for repairs. For it is doubtful that the most sophisticated engineers in our gadget-minded world could construct an instrument as efficient and fool-proof as the human eye. On a screen no larger than a thumbnail it gives us miles of scenic landscapes and the twinkling of stars in a night sky, a baseball game, a panorama of city sky-

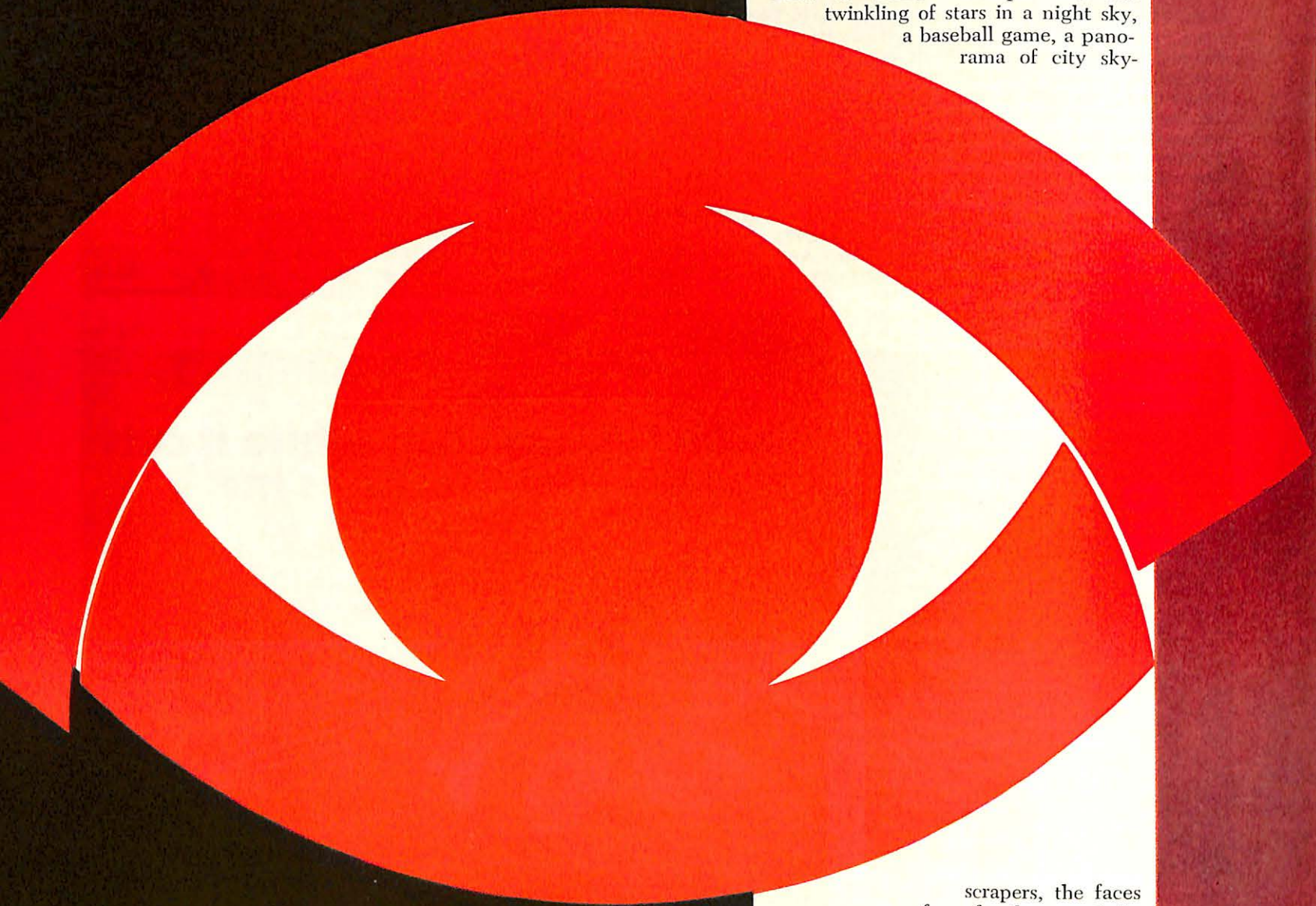

# THE THIEF OF SIGHT

scrapers, the faces of our family around the dinner table—all in full color and in what appears to be life size, even though some details on the retina itself are microscopic. Such man-made marvels as radar, television and guided missiles just can't compare with the eye for precise, delicate, tireless performance.

Considering their superfine construction, the wonder, then, is that our eyes don't get out of order more often than

---

by G. R. von Kronenberger



they do, and that of the more than 220,000,000 pairs in this country only about 500,000 are blind. But it is even more amazing that, when it takes so little to keep our eyes working right, that little is so frequently neglected. A large proportion of blindness is definitely preventable—a truth as plain as night follows day—if only people will act before it is too late. According to the National Society for the Prevention of Blindness, half of all cases of blindness occur needlessly, and could be prevented with current medical knowledge and techniques. It is indeed tragic that in the next 12 months an estimated 46,000 more people in the United States will become blind—and 23,000 of these cases could be prevented.

Of the physical qualities that have been given to us, the one we value most is vision. A recent Gallup poll revealed that among physical afflictions, Americans fear blindness second only to cancer. It seems odd, therefore, that we take relatively little trouble to guard properly that most precious gift which, like other priceless things, must be guarded or it may be lost.

One of the greatest opportunities for preventing men and women from entering a dark tomorrow lies in the field of glaucoma. The second leading cause of blindness in the middle and late years of life (cataract is the leading cause), glaucoma is becoming an ever more serious problem as the proportion of older people in our population increases. In the past year, more than 6,500 persons lost their sight to glaucoma, and it is estimated by the National Society for the Prevention of Blindness that glaucoma is responsible for a total of 66,000 cases of presently blinded persons. In addition, it is estimated that 2,000,000 persons in the

**A large proportion of blindness is preventable, if only people would act before it's too late.**

United States have glaucoma. *Half of them are not aware of it, and face vision impairment or blindness without treatment.* Some think that the occasional blurring of vision is only early cataract and ignore the clue. Others have virtually no symptoms. Yet, with this disease time is precious—the delay of treatment for even a month can mean a loss of part of the vision. Sight lost to cataract can be restored—that lost to glaucoma is gone forever.

Nevertheless, we don't need miracles to save most glaucoma victims from blindness. What we do need is a wider use of sound medical procedures—some new and some old—which have already salvaged countless years of imperiled vision. And when the medical "light lines" are thrown to these glaucoma victims, they must hang on if they are to be saved—a point which many of them ignore. For in few conditions does the punishment so inexorably fit the crime of delay, interrupted or inadequate treatment.

And though sight lost to glaucoma cannot be restored, early diagnosis and prompt treatment can bring glaucoma under control and permanently halt its progress in most cases.

Glaucoma isn't a new disease. The word "glaucoma" is from the Greek words *glaukos*, which means sea-green, and *oma*, a general term indicating a disease condition. "If the pupil becomes sea-colored, sight is destroyed," it is stated in the Hippocratic Aphorisms, "and blindness of the other eye often follows." The word was used by Hippocrates, four centuries before Christ, for any eye disorder in which the normal blackness of the pupil was replaced by a grayish or greenish color. Because of this, for many years in the early history of medicine, cataract was confused with glaucoma, although they are in no way related. In glaucoma, hardness of the eyeball is produced by the accumulation of fluid within it, the normal drainage system being upset. In cataract, cloudiness develops in the lens. The difference between these conditions was first discovered by a French ophthalmologist in 1709, but it was not until a century later that the real cause of glaucoma was discovered. It is supposed to have caused the blindness of the English poet John Milton. In 1830, William McKenzie, the famous Scottish surgeon, wrote a classic description of glaucoma—and in the middle 1880's, Dr. Albrecht van Graefe, of Germany, performed the first operation which saved a patient's sight.

Currently, a nationwide campaign of information and education to awaken Americans to this treacherous eye disease, the Glaucoma Alert Program, is being directed by the National Society for the Prevention of Blindness. Regional and local campaigns are being conducted by such organizations as the National Eye Institute, Public Health Service, American Red Cross, and others.

It is a drive to save the eyes and skills of thousands of trained men and women whose loss of earning power at the present time is estimated to be approximately 200 million dollars.

In many cases, a highly skilled worker who develops this disease and does not receive proper treatment early enough finds that his sight is impaired and must accept an inferior job requiring less skill and precision and with less pay, so that his entire standard of living becomes disrupted and the morale of his family is greatly disturbed. If, however, the early signs of glaucoma had been recognized and early treatment had been given by an eye physician, the failing sight might have been halted and the patient would have been able to continue a normal life.

What is glaucoma? Doctors aren't sure. It isn't caused by germs—although a diseased condition in the eye produces glaucoma as a secondary condition. Glaucoma may be partly hereditary and partly due to poor general health or unwise living habits. Some doctors refer to it as "a sick eye in a sick body."

Glaucoma does not refer to one disease entity, but rather to a series of failures within the eye. All of them, however, have one condition in common: increased pressure inside the eyeball. It is this increasing pressure which destroys the optic nerve. Most of the

**Sight lost to cataract can often be restored, but sight lost to glaucoma is gone forever.**





time, sight is lost slowly but surely over a period of years. Yet the disease is practically symptomless and the victim is scarcely aware of what is happening. It seems difficult to believe that a person can gradually lose his sight without being aware of it, but there's a good explanation.

The human eyeball is best described as a hollow sphere about 1 inch in diameter containing the various organs of vision. Filling all the spaces between these organs are transparent substances, one of them jelly-like (vitreous humor), and one a colorless, watery fluid called aqueous humor. It is called "aqueous" because it is a clear, salty liquid. This fluid leaves the bloodstream, flows through the pupil, and back into the blood stream again through an outlet which is known as the Canal of Schlemm.

In the normal eye this fluid is like a moving stream. But in cases of glaucoma, an obstruction develops and the aqueous humor can no longer escape through the Canal of Schlemm. As more and more of this fluid is trapped, pressure increases. It's like filling a rubber ball with water. The more water that is added to the ball, the larger it gets. It's exactly the same with the eye. When everything is working smoothly in the eye, the outside of it is soft as a fingertip—but when excess fluid makes the pressure rise, it can become as hard as a fingernail, or even a glass marble. This increasing pressure becomes very dangerous. Inside the eye, on its back wall, or retina, are millions of tiny sensitive nerve cells connected to nerve fibers—and blood vessels, which carry the blood that nourishes them. Increased pressure, by reducing the blood supply, can destroy these retinal nerve cells and their fibers. A certain amount of sight is permanently lost with each cell and fiber destroyed. If glaucoma is allowed to progress unchecked, the victim is certain to become blind. Most of the time, too, both eyes are affected. Glaucoma is rarely kind enough to confine its damage to one eye and leave the other one alone.

Glaucoma appears in one of several forms—called specifically acute glaucoma and chronic glaucoma. In *acute glaucoma*—less common than the chronic—the drainage pathways inside the eye are suddenly blocked and vision can be destroyed so quickly that the victim must have immediate medical treatment if the eyes are to be saved.

"If the intraocular pressure is very high and immediate skilled medical help is not available, blindness may occur within 24 hours," says Dr. John G. Bellows, a Chicago ophthalmologist, reporting in a recent medical journal.

Sometimes these acute attacks are preceded by minor seizures that have recognizable symptoms. The pupil is enlarged, the cornea is hazy—vision becomes blurred and the victim sees red and green halos around lights. He also may have slight headaches and eye pains. The first attacks usually disappear in a short time. But as the disease progresses, they occur more frequently and more severely. At first they may be months apart, then weeks, then days.

Studies show that acute glaucoma attacks are often preceded by an emotional upset or a visit to a dark room. Glaucoma may be a form of hypertension, limited to the eyeball. In fact, some medical men think there may be a relationship between glaucoma and high blood pressure because it has been found that glaucoma sufferers have a tendency to develop high blood pressure.

*Chronic glaucoma*—by far the most common form—may be present without the victim's being aware that he has the disease. He may actually become nearly blind before he begins to wonder what's wrong. In chronic glaucoma there is no dramatic increase of pressure with the danger signs of redness, pain and blurred vision. The eye appears normal, feels normal and has normal vision—as vision is commonly tested. But all the time irrevocable damage is occurring. The nerve cells which are first crushed to death by the high pressure are not those few cells in the center of the light-receiving area which are responsible for the fine 20/20 vision the eye has when it looks straight ahead.

When chronic glaucoma begins to destroy sight, it starts at the outermost extremes of the field of vision and gradually works towards the center. This means that while a person with glaucoma may have no trouble seeing straight ahead, his "side vision" may have been completely destroyed, often without his knowing it.

When you look ahead, you see not only what's directly in front of your eyes, but also objects to either side. Focus your eyes on a chair in your room, and you'll see not only the chair but other things which stand to the sides of it. If a person with the beginning of glaucoma looks at the chair, he'll see it clearly enough, but he won't be able to see as much of the surroundings as a person with normal vision.

As glaucoma progresses, his field of vision narrows until eventually he'll see

(Continued on page 16)



• The "You and Retirement" column (April, 1979) by Grace W. Weinstein, was confusing. She lists the new amounts of income that those 65 and over may receive without being subject to tax. Is this the amount one can earn or the total amount of income from all sources? I thought it was the amount we could earn without paying taxes.

David N. Levin  
Wyomissing, PA

*The April column does not refer to tax-free earnings but to tax-free income. Its information comes directly from the Senate's Special Committee on Aging. The memorandum on the 1978 tax bill reads, in the pertinent section: "The amount of taxable income that elderly taxpayers (65 years or older) may receive and not be subject to tax is increased (effective in 1979) from \$4,200 to \$4,300 for individuals and from \$7,200 to \$7,400 for couples. In addition, taxpayers may have Social Security (up to \$5,876 a year for individuals with maximum-covered earnings who retired at age 65 in 1978 and \$8,815 for elderly couples similarly situated), which is exempt from Federal income tax."*

*Social Security benefits are not taxable. Most other income, whether from earnings or from interest on savings or from any other source, is taxable, subject to the new exclusions.*

Grace W. Weinstein

• Larry Holden's article, "Pass the Beef, Beans and Broadway," (February, 1979) warmed many hearts in Lake City (Seattle) Elks Lodge No. 1800. An Elks cast has presented "The Drunkard" in ten sellout performances—and especially for the 111th anniversary of Elkdom. This performance brought nostalgic reminiscences of the Jolly Corks and their efforts. Our director, Stan Cole, is now casting "Ten Nights in a Barroom."

Frank Leighton  
Seattle, WA

• The opportunity to study French in France for \$8.50 a day, as mentioned in the "1979 Guide to Travel Bargains" (April, 1979) by Jerry Hulse, seems too good to be true. Would he know of anyone in a Spanish-speaking area offering something similar?

Donna Hunnicutt  
Cheyenne, WY

*Contact the Spanish National Tourist Office at 3160 Lyon Street, San Francisco, CA 94123; or write to Rolando Torres at the Mexican National Tourist Council, 9701 Wilshire Boulevard, Beverly Hills, CA 90212.*

Jerry Hulse

*CORRECTION: The adult fare for the "All Around Town" Grey Line tour in Dallas is \$7; for children, the fare is \$3.50.*



# MEDICINE AND YOU

by Larry Holden

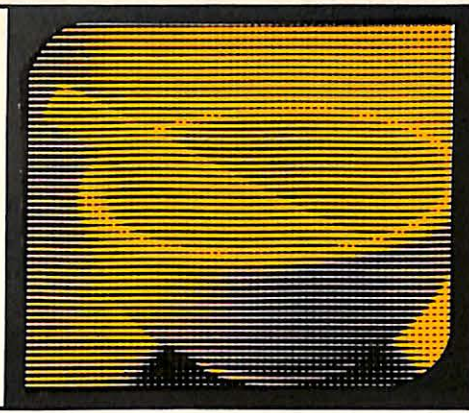

## CATARACTS: SEVERAL SOLUTIONS

One of the things we often don't appreciate—unless we begin to lose it—is our vision. The key to good eye care is regular eye examinations by a vision specialist. Frequently, problems can be detected and corrected before they result in serious loss of vision.

There are some conditions that cannot be prevented; however, many of these can be treated with positive results. Cataracts, for example, are the greatest single cause of blindness among adults in America today. The good news is that the cataract surgery success rate is 95 to 97 percent.

The word "cataract" makes a lot of elderly people shudder. Yet cataract surgery is so improved and simplified that this year a half million Americans—most of them over 65—will undergo successful surgery to correct visual losses caused by cataracts. In fact, if you have a cataract operation, you'll probably be out of the hospital the same day or the next. Nevertheless, apprehension is understandable. The operation removes the lens of the eye. A few years ago, it meant 10 days or more in the hospital, part of the time with your head propped between two supports.

A cataract is *not* an infection, is not contagious and is not a skin growing over the eye. These are all common misconceptions. A cataract is cloudiness in the crystalline lens of the eye or of its capsule; this clouding or opaquing of the lens reduces the amount of light passing through. The lens, a structure inside the eyeball, is about the diameter of an aspirin tablet and hangs like a curtain near the front of the eye.

Normally, the lens is clear, transparent, and colorless. It refracts the light passing into the eye and relays it to the retina, which is the nerve tissue in the back of the eye. When activated by light, the retina transfers its message on to the brain. This is how we see.

A cataract blocks some of the light passing through the lens and is generally described as any clouding of the lens of the eye. Cataracts are most common in older people. However, it is possible for even young children to develop them, and some infants are born with the problem. Also, "traumatic" cataracts may occur after an injury or a blow to the eye.

The symptoms can include blurred or distorted vision, especially at a distance,

and "floaters" (small black specks seeming to appear before the eye). Cataracts are painless, although they do cause an unusual ailment known as photophobia, an intolerance of light.

The only treatment in the great majority of cataract cases is to remove the lens, permitting light to come into the eye unobstructed. The most common way has been to freeze the lens onto a "cryoprobe" and extract it through a small incision in the iris. Another way is to draw the lens through a small hollow needle by suction. A still newer technique called phacoemulsification is gaining favor as a way to shorten recuperation time. It uses ultrasonic vibrations to liquefy the lens, which is drawn through a smaller needle requiring a smaller in-

cision. Precise work and faster healing also result from microscopic surgery with tiny instruments and with suture material so fine it floats in the air.

The best time to operate depends on the progress of the cataract, the amount of vision lost and the type of work the patient does. Age is seldom a factor in deciding whether to operate. In fact, after their sight is restored, many elderly cataract patients report better overall mental and physical health, along with a brighter outlook for the retirement years.

To accomplish the operation, you may have to miss only a few days of work. Dr. Joseph Spina Jr. of Delaware County Memorial Hospital in Drexel Hill, PA, uses ultrasonic and microscopic procedures for operations Saturday mornings, often releasing patients the same day. Short hospital stays are especially helpful to elderly patients, for whom long inactivity is a health threat. You have some pain after cataract surgery, and complete healing takes several weeks. Still, your chances of greatly improved vision are very good.

Although some vision is restored as soon as the cataract is removed, the eye cannot focus without a lens. It is, therefore, necessary for the cataract patient to compensate for the lost lens. Glasses are usually prescribed, but it may also be possible to wear contact lenses or to have intraocular lenses surgically implanted.

After cataract surgery without lens implants, the common glasses required (Continued on page 27)

## Three of America's Last Great Antique Buys!

Carefully Restored  
Hardwood Cases.  
Approx.  
22" H, 13" W, 4½" D.

When they're gone, they're gone forever.  
Genuine Circa 1900 Antiques.



The Parlor Clock  
\$85.00  
(Approx. 20" H,  
9½" W, 4" D.)

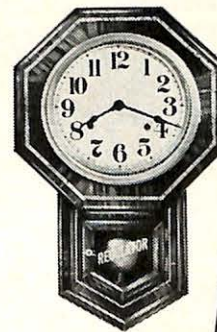

The Traditional  
Schoolhouse Clock  
\$105.00  
(Approx. 19" H, 12" W, 4½" D)



The Fancy  
Schoolhouse Clock  
\$135.00

URGENT NOTICE  
These  
Antique  
Clocks  
at these low  
prices are  
going, going,  
going...  
ORDER  
NOW!

We urge you to take heed. These are truly the last of the Great Old Clocks. At our low price, you may never see these values again. Authentic circa 1900 antique schoolroom clocks, the kind that once ticked happily away in the front parlours, general stores and one-room schools of America's childhood. Lovingly restored and in 100% running order. Each is unique—yours will be numbered, registered to your family or whomever you designate and accompanied by a handsome Certificate of Age and Ownership (suitable for framing). Order now, to avoid disappointment. When these clocks are gone, they're gone forever.

- Certificate of age, authenticity and ownership.
  - Fully re-conditioned 8-day keywind movement, brass pendulum, key. Counts each hour in melodic tones.
  - Sturdily cartoned and shipped to you UPS insured. (Clocks will vary slightly in trim and wood tone.)
- For multiple orders use separate sheet of paper.

Visit our Showroom, just 1 hour from N. Y. C.  
Pony Express System 2986 Navajo St.  
Dept. M-721, Yorktown, N. Y. 10598  
Gentlemen: Please send me the following clock(s) (state qty.):

The Parlor Clock (Style 18) @ \$85.00  
 The Traditional Schoolhouse Clock @ \$105.  
 The Fancy Schoolhouse Clock (Style 12) @ \$135.

Choice of  Arabic or  Roman Numerals.  
(Add \$8.50 for each insured delivery.)

My check is enclosed for \$ \_\_\_\_\_  
(N. Y. State residents add 5% tax.)

We honor Master Charge, American Express & VISA.  
Include signature and appropriate data or for faster service  
call 914-248-7031 9 a.m. to 5 p.m. (E.S.T.)

Mr./Ms. \_\_\_\_\_  
Address \_\_\_\_\_  
City \_\_\_\_\_ State \_\_\_\_\_ Zip \_\_\_\_\_

\_\_\_\_\_ Satisfaction guaranteed or money refunded. \_\_\_\_\_



# Glaucoma

(Continued from page 14)

only things right ahead of him. Even then he may not know what's wrong, though, for he'll be able to see perfectly clearly when he reads or writes or talks to someone standing in front of him. Left untreated, such a person eventually becomes completely blind.

If you hold up two tubes to your eyes, and look through them, you'll get an idea of how a person sees with advanced glaucoma. You think that you'd be sure to notice anything like that if it happened to you, but when it happens to a person as gradually as glaucoma usually does, it's quite possible to be unaware of it.

Glaucoma principally affects the aged, an outcome of normal physiological decline. Anatomy, however, also plays a part. The markedly farsighted eye may be more prone to the disease than the normal or nearsighted.

But in general, glaucoma is seen more frequently in women, and is most prevalent in both men and women over 40 years of age, in those with diabetes and in those who have a parent with glaucoma. Such symptoms as dimness of sight, colored rings around lights, a

feeling of tension in the eye, or headache sharpening into pain are danger signals.

But you must not wait for the symptoms of chronic glaucoma. No one is immune and all people should be tested. The best defense against glaucoma, recommended by the National Society for the Prevention of Blindness, is an eye examination and a simple testing procedure called *tonometry* every other year after the age of 35.

How is this testing done? Very easily. The ophthalmologist puts a drop in the patient's eye and in a few seconds the cornea is incapable of feeling anything. A device called a tonometer, invented by Dr. Hjalmar Schiøtz in Norway more than 70 years ago, is then placed in contact with the eye while the patient either lies back or sits in front of a large instrument called the slit lamp. These instruments tell the doctor how hard the eye is. The test is completely painless, over in a few seconds, and leaves the vision unaffected.

If the tonometer shows a high reading, which is an indication of glaucoma, further testing is done with a gonioscope. This device consists of a mirror or prism and a contact lens and is used for viewing the angle of the anterior chamber (where the cornea and

iris are joined) of the eye. In this way, the examiner can determine what type of glaucoma a patient has. Other tests for visual acuity, for peripheral vision, as well as for the condition of the optic nerve, also will be done.

Once the diagnosis is made, the treatment usually consists of medication. In treating glaucoma, doctors say that first control should be attempted with a group of drugs known as "miotics." These are eyedrops that generally act on muscles and tissues to increase their drainage efficiency.

Occasionally, medicines are not sufficient to keep the pressure down and then surgery becomes necessary.

To try to eliminate the need of daily eyedrops for glaucoma patients, soft contact lenses have been used experimentally to time-release medication to the eyes for as long as a week.

Even if medical advances go slowly, most people right now, with properly diagnosed and conscientiously treated glaucoma, can live their lives relatively free of the threat of blindness. If you are in a glaucoma-prone group, tomorrow's medical miracles could be too late. But an accurate test of your eye pressure now can relieve your mind or alert you in plenty of time to arrest this insidious sneak thief of sight. ■

## ELKS NATIONAL SERVICE COMMISSION

"So long as there is a disabled veteran in our hospitals, the Benevolent and Protective Order of Elks will never forget him."



The Brothers of Jupiter, FL, Lodge visited with residents of the local VA hospital recently. District Vets Chm. Nelson Day, Harry Swab, John Roth, and ER Ralph Denton were among the Brothers who joined the vets for the afternoon's event.

An arts and crafts contest was sponsored by the Ohio National Service Commission recently. Designed to benefit the veterans at the VA Center in Dayton, winners were selected according to the therapeutic value of the effort and creativity shown in the finished product. Carl Scott (center), first-place winner, received a \$50 check from PER Byron Davenport of Dayton Lodge and PDD Marc Humpert.



Physical therapy materials were donated to the Altoona VA Hospital by Lewistown, PA, Lodge recently. The gifts were presented by (from left) District Chm. William McGill, ER Donald Sachs, Est. Loyal Kt. and Chm. Charles Hoffman, and PDD R. Max Gunderman. Lewistown Lodge has donated books, games, clothes, and equipment estimated to be worth more than \$3,500 to the hospital.





## Police Pursuits

(Continued from page 8)

of 25 accidents. Of course, not all were related to Code 3 pursuit driving, but there were many officers trying to move from one part of town to another and driving too fast for conditions.

Police Chief Bastrup decided enough was enough. He leaned hard on the patrolmen by making a few changes in the pursuit procedures. The most startling one to many of the young officers was the speed limit he clamped on his units. He prohibited them from driving more than 15 mph over the posted speed limit, unless they were pursuing a felon.

It was mainly a sense of wanting them to use their brains and modern technology to stop the violators. But the police officers' egos were on the line, and many of them chose to ignore the new regulations.

Shortly thereafter, the police union challenged him, giving him a vote of no confidence. Immediately the city council gave Bastrup a total vote of confidence. By this time, the entire affair had made the press. A backlash came from the public with 1,300 letters and telephone calls coming in—not one against the chief's actions.

Local citizens even stopped patrolmen on the streets and asked them, "Where did you get the idea that you could drive a patrol car any way you wanted to?"

By December, the APD was honored by the National and State Safety Council. Their accident rate for the year had dropped 90 percent. Now there was very little hard feeling in the ranks. They were proud that no officer or citizen had been killed or even seriously injured because of high speed driving by the officers.

"The public in many communities are becoming acutely aware of police officers trying to play Starsky and Hutch roles," said Bastrup. "This type of police procedure is unnecessary with today's technology.

"Most of the time you have helicopters and radio communications. If you can get the license number, a pursuing officer can get an instantaneous make on a car through police computers and soon know if it's a stolen car or just a speeding teenager that you can pick up later at his home."

On the present scene, an important factor is that pursuing officers become intoxicated by the excitement of the chase, the pitch of the siren and the higher flow of adrenaline brought on by the high speed as they roar through traffic. It enhances the chase and makes it hard to decide on the best course of action.

## Money isn't the only reason to start your own business



A lot of people start their own business for the pure satisfaction of it. Being your own boss. Making your own decisions. Establishing your own lifestyle.

If you too want the satisfaction of your own business, consider General Business Services.

GBS is one of the nation's leading small business counseling firms, with franchises in every state. We've started nearly 1000 career-minded men and women on the road to their own business counseling practices. And we can help you get started, too.

As an independent GBS counselor, you'll work with other businessmen and women—right in your own community—providing the professional recordkeeping and management services almost every small business needs.

An investment of \$15,000 covers complete training, supplies, and the full technical support of our large national office staff. Even if you've never had formal training in business or accounting before, the time-proven GBS system can make you your own boss in just a matter of weeks.

Use the coupon below to find out more about the rewarding career opportunity GBS offers you.

©1979, General Business Service, Inc.

Please send me your free brochure, "An Investment in Yourself and Your Future," about a GBS career.

Name \_\_\_\_\_

Address \_\_\_\_\_

City \_\_\_\_\_ State \_\_\_\_\_ Zip \_\_\_\_\_

Phone \_\_\_\_\_



Robert Turner, Vice President  
General Business Services, Inc.  
Department EM-U-7  
51 Monroe Street, Rockville,  
Maryland 20850



### DOG WASTE GONE

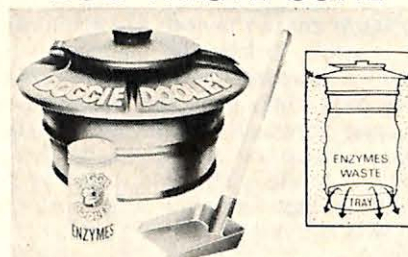

**DOGGIE DOOLEY®** keeps grounds clean, insect-free, sanitary. Rustproof heavy plastic doggie septic tank installs in ground; uses safe, non-poisonous enzyme-bacteria to liquefy pet stools for ground absorption. Shovel up stools, drop into tank, close lid. Enzyme-bacteria action does rest. Harmless to pets, lawns, shrubs. Handles wastes of 1 to 3 dogs. 17½" x 11½" with foot-operated lid, shovel, 6 mos. of enzymes, and moisture holding tray for faster action. \$14.97 plus \$2.85 shpg. Extra 12 mos. enzymes \$3.95 plus 85¢ shpg.

**HOLST, INC.** Dept. ER-79, 1118 W. Lake, Box 370, Tawas City, Mich. 48763.



### WATER MINDER—

With automatic shut-off control. Now your lawn can have the water it requires, and you will never forget to turn off the hose. Attach the water-minder to spigot, dial the amount of water you want and forget it. Measures 0 to 1,500 gallons. Readily adaptable to most water control situations. Only \$11.47 plus \$1.50 postage and handling, or buy two for \$21.50 plus \$2.00 p&h. Write now, while supply lasts to: Holst, Inc., Dept. ER-79, 1118 West Lake, Box 370, Tawas City, MI 48763.

### NEW High Branch TREE SAW

Outreaches and Outworks any Pole Saw!



### CLOSEUP OF PATENTED CUTTING CABLE

Easily clear branches hanging over roofs, windows, play areas, gardens and pools. Revolutionary new "saw on a rope" cuts small and large branches, live or dead, up to 30' and higher while you stand safely on the ground. New concept has flexible steel cutting cable with round carbon steel saw teeth. Cable is attached to control lines and safety sandbag throwing weight. Simply toss weight over the branch you want to cut down, cable automatically positions itself in place, and then pull alternately on each control line to saw down branch. Avoid the hazard of climbing ladders with a hand saw or a chain saw. Avoid the expense of hiring a tree service. **HOMEOWNER MODEL**—3 Foot flexible steel cutting cable, two 25-ft. control lines. Total length 53-ft. \$14.97 plus \$2 shpg. **DELUXE PROFESSIONAL MODEL**—4 foot flexible steel cutting cable, two 45-ft. control lines. Total length 94-ft. **PLUS ADDED BONUS**, 2 sturdy hand straps. \$24.95 plus \$3 shpg. Both models come complete with storage pouch, safety throwing weight and instructions.

Send check or M.O. 20 day money back guarantee.  
**HOLST, INC.** Dept. EKR-79, 1118 W. Lake, Box 370 Tawas City, Mich. 48763





## ELKS ROAD SIGNS

Welcome visiting Elks to your Lodge by erecting these signs on highways into your city. 30" Emblem sign in official colors. Fiberglass Reinforced Plastic—strong, lightweight; 10" x 24" "Modulite" plate with 3 lines of lettering.

**\$41.40** F.O.B. Factory Pennsylvania  
2 or more, same lettering, **\$39.30**

Allow 4 weeks for shipment (We do not supply post)

MANCHESTER LODGE NO. 430  
352 MAIN ST.

To serve you better, we have moved to larger, more modern quarters.



## RUSSELL-HAMPTON CO.

Dept. E, 2550 Wisconsin Avenue  
Downers Grove, Illinois 60515  
(A Chicago Suburb)

## Maxi-Barbeque

8

Models

Optional accessories include pancake griddle, loin basket, automatic thermostat, safety switch and pilot light.



Holstein Manufacturing, Inc.

Box 135 • Phone 712/368-4342 • Holstein, Iowa 51025

World's largest suppliers of gun parts

NEW for **'79** 8th EDITION  
CATALOG #8 ONLY \$2.95 (4 color cost \$3.95)

this catalog "THE LARGEST EVER" page after page of many difficult and hard to find new and obsolete parts, stocks and barrels.



**NUMRICH ARMS CORPORATION**  
WEST HURLEY, N.Y. 12491

Box E TELEPHONE: AREA CODE 914 679-2417 Telex #145331

## BOOK AUTHORS!

Join our successful authors in a complete, reliable publishing program; publicity, advertising, handsome books. Send for FREE report on your manuscript and *Publish Your Book*.

**CARLTON PRESS** Dept. ELS  
84 Fifth Ave., New York, 10011

FREE



SHARING **THE SALVATION ARMY** IS CARING



## HEARING AIDS

**SUPER SAVINGS!** Newest, Finest. All types. Buy DIRECT & save up to HALF! No salesmen. Sold by AIR MAIL on HOME TRIAL FREE Catalog. Write: **MON-Y-SAVE-HEARS**, Dept. EK-7, 9530 Langdon Ave., Sepulveda, Cal. 91343

SAVE 1/2!

FREE CATALOG — WRITE!

# IT'S YOUR BUSINESS

by John C. Behrens

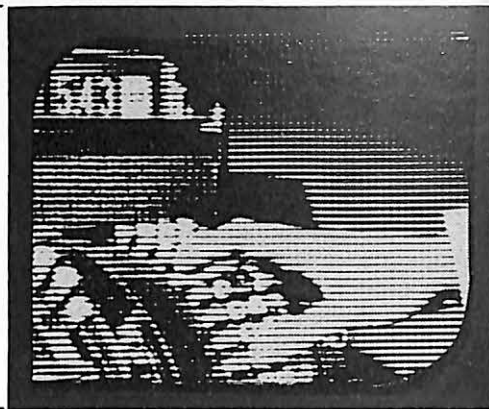

## WILL THE ECONOMY COOL?

Federal officials are reluctant to give any hard assurances about the health of the economy for the remainder of 1979. The truth is (as this column predicted earlier in the year) a number of experts believe inflation will be very close to double digit figures by January 1, 1980.

"Even as the economy starts to cool, it's absurd to think otherwise," a business acquaintance, who monitors the economic climate, told me.

"I think that if you want to look at the wholesale price index it would be naive to say that consumer prices are going to go down in the next few months. Yet, I think there's a good chance that President Carter's economic policy, which basically treads the middle ground, can get the economy into a soft landing so that we can avoid a recession," says Robert W. Dietsch, public affairs director of the Office of Management and Budget.

Dietsch doesn't believe the administration is going to lose the battle over the economy, however. "The economy is much better than many expected. We think we can cool things down and get inflation under control by the third or fourth quarters. At the same time, I can appreciate the pressures on the small businessman who is trying to keep his costs under control."

Every administration, of course, has had its internal bickering about just how to accomplish such a task, and the Carter cabinet and external agencies are certainly no different. Public comments in recent weeks by Treasury Secretary Michael Blumenthal, Labor Secretary Ray Marshall, Commerce Secretary Juanita Kreps and Federal Reserve Chairman William Miller have compounded the confusion. Blumenthal, for example, advocated a tighter money policy, Marshall opposed, and Kreps, who first supported Blumenthal, later backed away, saying, "While inflation remains much too high, there are good reasons to think that the worst of it may be behind us."

Kreps, explained the *New York Times* recently, saw "some hope for price deceleration" in the first quarter figures. She admitted that the overall rate of inflation was a whopping 9.7 percent, but she insisted that raises in programs mandated by Congress—Social Security and minimum wage—accounted for 2.2 percent of that figure.

Administration members are also di-

vided over what to expect during the remainder of the year. Blumenthal and others think that if 1978 statistics are used, the second quarter could race ahead as it did last year. Kreps and Miller have predicted increases during the second quarter, but both maintain any acceleration will be mild. They insist that the second half of the year will be sluggish, adding that a slowdown with a probable rise in unemployment will avoid a recession and produce less price inflation.

Miller thinks that the first two quarters of 1980 will continue at a sluggish pace. The economy, as he sees it, will probably pick up again in the second half of next year.

What advice does Dietsch have, then, for the small businessman in the months ahead?

"I would say keep within the Carter Price-Wage Guidelines and complain like hell if your bigger competitors or associates don't. I think that we have to realize that government cannot control inflation alone. I just don't agree that the federal deficit is the main or only cause of inflation. It's a matter somehow of getting away from this preoccupation with self and realizing that the only way to get a handle on inflation which hurts everybody, and probably hurts small businessmen more than the big business people, is to cooperate."

Some believe, however, that Carter simply isn't getting good economic advice. Critics further contend that OMB, which is supposedly involved in every decision that evolves from budget, management or financial questions, has created some of the problems.

"I don't think any administration can do away with an Office of Management and Budget," Dietsch says. "We need an organization that can prepare the budget and supervise the budget after it's sent to the Congress by the President. You need a management arm of the federal government to look at the way programs are administered and managed. In the case of the Carter Administration, I think OMB is more important than ever, not only to carry on the budget function but for the management side, too."

"We're involved in the things the President is interested in. We're in charge of reorganizing the executive branch, and we're in charge of trying to do something

(Continued on page 27)



# NEWS OF THE LODGES

Eight teams from area schools competed in the sixth annual Eighth Grade Invitational Basketball Tournament sponsored by **Greenwich, NY, Lodge**. Brother George Pfeiffer presented trophies to Kevin Waldron for first place, to Tim Milliam for second place, and to Dale Reid for third place.

A Bonanza Day, sponsored by the Student Aid and the Cerebral Palsy committees of **Waynesboro, PA, Lodge**, brought in \$500 for each fund. Currently, five students receive scholarships from the lodge, while the CP fund helps those in the South Central District. Brothers from Hagerstown, MD, Lodge helped to make the Bonanza Day a success.

Undaunted by years or miles, Brother Fred Mansuis of **Pompton Lakes, NJ, Lodge** has driven 28 miles to his lodge and back every week to supervise bingo for handicapped children. At 88 years of age, Brother Mansuis is one of the oldest members of Pompton Lakes Lodge.

The Brothers of **Clear Lake (Kemah), TX, Lodge** burned their mortgage recently. Participants of the event were ER Marvin Kennedy, Grand Trustee Edward Schlieter, Esquire Ray Vacek, PERs Charles Nagle and Robert Nicol, and SDGERS James Sharp and Gene Norton.

Trophies were presented to young athletes by **Woodland, CA, Brothers** during a dinner held at the lodge. The honored athletes included (from left) Rudy Lucero, Marcia Gagnon, Marcelo Matta, Ray Rojas, David Snow, and Scott Teuscher. Est. Lect. Kt. Ron Fritz showed the youngsters around the lodge.

*Young athletes were guests at Woodland, CA, Lodge.*



Young women from 11 Rockland County high schools in New York competed in a track and field meet sponsored by **Pearl River, NY, Lodge** recently. Annette Naples crossed the finish line to win first place for Albertus Magnus High School in the four-mile relay race. Pearl River Brothers plan to invite schools from Orange and Westchester counties to participate in next year's women's track and field event.

Approximately 350 senior citizens enjoyed a party held for them by **Enfield, CT, Lodge** recently. DDGER Samuel Browne and ER James Captain served as waiters during the evening.

Eye injury prevention among youths was the theme of a poster contest sponsored by **Burns, OR, Lodge** recently. Winner Darren Boyd received a \$50 savings bond and the second- and third-place contestants each received \$18.75. Barry Hatcher presented the prizes to the children, who will enter their posters in the district competition.

The Waynesboro East-Augusta CPR program benefited from a donation of nearly \$1,000 made by **Waynesboro, VA, Lodge** recently. ER T. James Goode and Est. Lead. Kt. Lewis Sweet presented the check to Dr. Thomas Gorsuch. Plans were made to use the contribution for the purchase of a Recording Resusci Anne, which is a CPR teaching device.

The 73rd Annual Old Timers Sunday Wrentham-Foxboro Celebration took place at **North Attleboro, MA, Lodge** recently. 50-year pins were pre-



*Annette Naples crosses the finish line.*

sented to Brother Pat Smith and PER and Chap. Russell Cook, who presided over the initiation of 12 new members during the affair. On hand for the day's events were SP Edward Lynch, PSP Harry Sarfaty, VP Joseph Silvia, and PDD Guistino Marsella.

Nine Brothers of **Westwood, NJ, Lodge** were honored for their dedication to the order on Old Timers Night recently. Life memberships and 25-year pins were proffered by ER Frank Roth. PER Samuel Williamson acted as emcee for the evening's event.

**Santa Monica, CA, Lodge** hosted the South Coast District Elks marshaling team for the Glen Campbell Los Angeles Open Golf Tournament recently. The team included 52 Elks from seven lodges. They were assigned to the eleventh hole for crowd control, and part of the team carried tote boards and accompanied the golfers for 18 holes.

Proceeds from the annual Charity Ball held at **Summit, NJ, Lodge** went to the Union County Association for Retarded Citizens. CP Chm. Kenneth Krohn presented the donation to Jeffrey Jackson of the Union County Association, which operates a satellite program for retarded and handicapped infants.

Eagle Scouts received certificates and American Flags from **Charleston, SC, Lodge** recently. Presentation of the awards was made during a ceremony at the lodge, followed by a dinner held in the Scouts' honor.

## State Association Conventions

State	Date	Place
CO	9/6 thru 9/8	Colorado Springs
MD, DE & DC	6/29 thru 7/1	Easton, MD
MT	7/25 thru 7/28	Butte
WV	8/9 thru 8/11	Princeton





**PAST AND** present officers of Derry-Salem, NH, Lodge participated in the Easter Seal Telethon sponsored by WMUR-TV in Manchester, NH, recently. The Brothers answered telephones and accepted the pledges made by the viewers of the program. On behalf of the lodge, ER Robert Wilkesman (right) presented \$100 to Master of Ceremonies Bob Lobel of WBZ Radio in Boston.



**FUNDS** raised by the Elks' ladies of San Mateo, CA, Lodge through their monthly luncheons were donated to the California-Hawaii Elks Major Project recently. Ms. May Broughan (right) presented the \$459.80 check to Major Projects Chm. Jim Buchan. The major project provides aid for handicapped children.

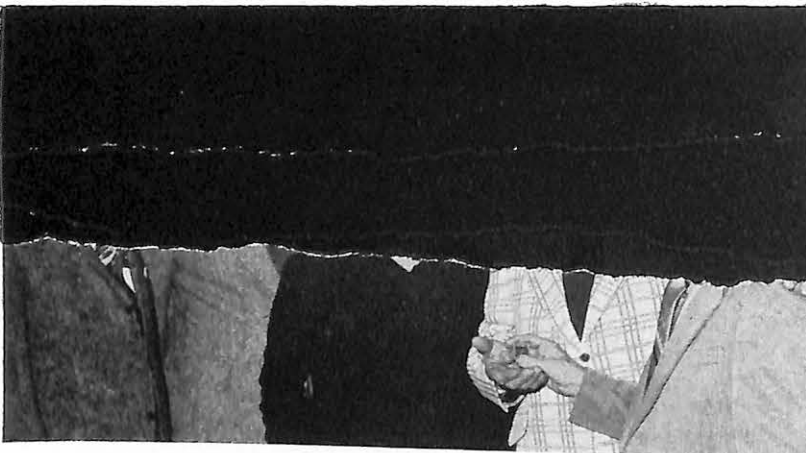

**SENIOR** members of Lambertville, NJ, Lodge were honored during Old Timers Night recently. PVP and Chm. Jack Stymiest (right) proffered old honorary life membership pins to (from left) Bill Mills, Sin Riordan, Dan Yannarella, and Jim Arcieri. Lambertville Brothers offered their congratulations to the old timers.

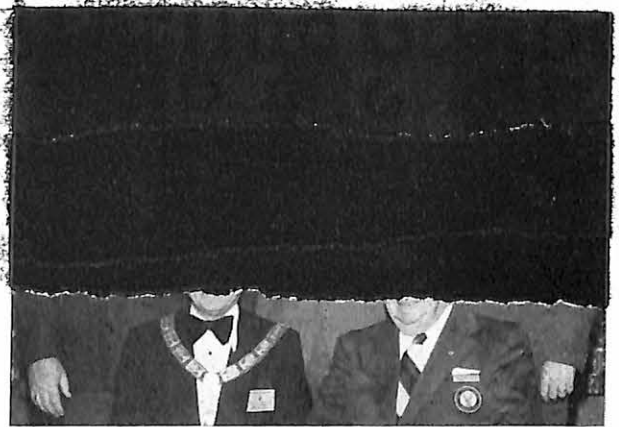

**GREETINGS** were extended by the Brothers of Carthage, NY, Lodge to DDGER Sterling Gaebel (seated, left) recently. Accompanying the DDGER on his visit to his home lodge was SDGER Francis Hart (seated, right). The two dignitaries joined (standing, from left) PDDs Charles McGraw, Charles Hale, and Thomas Gurnett, who are all members of Carthage Lodge.



**SCHOLARSHIPS** worth more than \$1,000 were awarded to winners of the district Most Valuable Student Contest held at Baker, OR, Lodge recently. District Chm. Robert Brown (second from left) and Lodge Chm. Bill Rengert (fifth) of Baker Lodge congratulated second-place winners Alan Nuss (left) and Bonnie Mann (right), who both received \$250 scholarships, and champions LaVita Dougherty (third from left) and Scott McBee, who both received \$400 scholarships. Ms. Dougherty and Mr. McBee prepared for the state competition.





**A GOING-**away party was held at Syracuse, NY, Lodge recently. The occasion marked Brother Al Meehan's (center) move to the Elks National Home in Bedford, VA. On hand to wish Brother Meehan good luck in his new abode were (from left) ER Charles Murray, Chm. Sam Demario, Ed Locklin, and PDD Lyle Rulison.

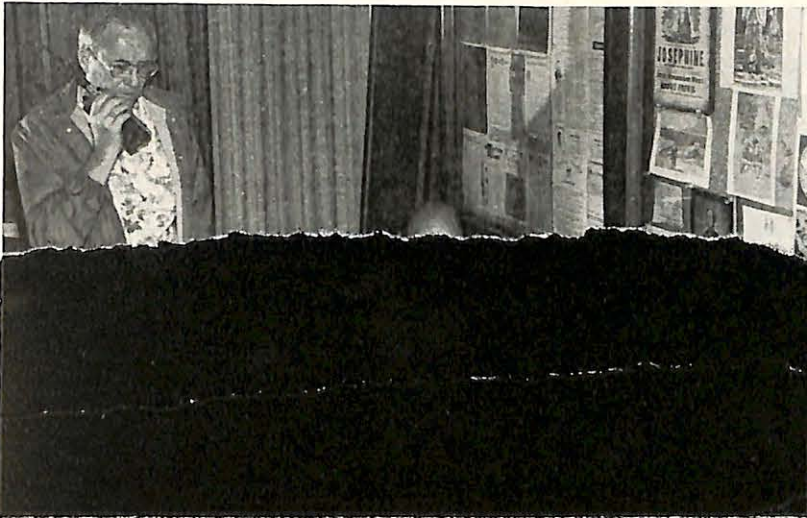

**AN ELKS** radio program was recently held at Escondido, CA, Lodge recently. The program will now be held at a local agency in Pomona, California, where a radio network is necessary. Brothers Bob King (standing), in Pomona (seated, left), and Wally Lynn began operation of the radio center.



**THE ELKS** Annual Youngster Sports Fund Dinner was held at the Elks Lodge recently. Presenting the check to the Elks Association was ER Allan Velander.



**A PROCLAMATION** announcing Escondido Handicapped Children's Day was formulated by Escondido Mayor Doug Best (right) and presented to Chm. John Tartaglia (left). The day was named to mark Escondido, CA, Brothers' fifth annual Festival of Music. The festival raises money each year for the Brothers' program called the Children of 1687, which includes aid to handicapped children and sponsorship of a free pre-school vision screening project.



**POMONA, California,** Brothers contributed a 19-inch color television set, a 15-cord autoharp, a check for \$455, and toilet articles to the Jerry Pettis VA Hospital recently. Dave Portillo (second from left), chief of voluntary services, thanked (from left) District Chm. O. J. Sparks, Lodge Chm. John Porto, and ER Richard Dempsey for the gifts.





**SENIOR** members of Salamanca, NY, Lodge were feted during Old Timers Night recently. The attendants enjoyed a dinner-dance and witnessed the presentation of a certificate of commendation to Treas. Daniel Fitzgerald (fourth from left). Brother Fitzgerald was honored for his service as treasurer since 1948 and received congratulations from (from left) PER James Keenen, Franklin Wildman, ER Lane France, and PERs Harold Warner and Richard Neal.

**COLLECTION** of aluminum cans for resale raised money for Fort Pierce, FL, Lodge's charity fund. Collectors Arthur Swartling (left) and Henry Banks (right) presented a \$100 check to ER Paul Testa (center), which makes a total of \$300 the two brothers have contributed this past year. The contribution is earmarked for the Harry-Anna Crippled Children's Hospital, the state major project.



**IN CONJUNCTION** with a celebration marking the purchase of new lodge facilities, Columbus, OH, Brothers welcomed 85 new members to the order. The ceremony was performed by the Past Exalted Rulers Association, and the class was named in honor of Brother Charles Hill (right). Immediate PER John Suedkamp (left) presented a plaque of appreciation to Brother Hill, who sponsored 77 of the initiates, including his son Robert.



**A SPECIAL** luncheon was held at Lincoln, NE, Lodge for Eagle Scouts and their leaders and parents recently. Federal District Judge Warren Urbom (third from left) was the speaker for the event. On hand to congratulate the Scouts for their accomplishments were (seated, from left) Chm. Bob Turner, ER Ralph Giebelhaus, SDGER Vincent Collura, Scout Executive Ralph Parker, and Est. Lect. Kt. James Rakers.



**OREGON** welcomed a new lodge to the order recently. The institution of Redmond Lodge was witnessed by local, state, and national dignitaries. Among those present were (from left) SP Bruce Reed, DDGER Clifford Rich, ER Ronald Rodman, PGER R. Leonard Bush and PGER Frank Hise.  
(Continued on page 32)



Mention the Suwannee River and we begin to dream of a peaceful solitude found and lost so long ago . . .



# Suwannee River Fever

by Bill Thomas

You can almost hear the heartbeat of the river as you sit along its banks or canoe upon its dark waters. The rustle and swish of the lazy water is remindful of the pace of life here. You can imagine the voices of heart-rending lyrics of the native peoples from long ago, and feel the earthshaking rumble of logs drifting down to the mills and the chop and slap of paddle wheel ghost boats that once plied their way along the jungle-shrouded waters of this immortal river. All that is now history.

This is America's most legendary stream; its very name is accompanied by visions that strum a romantic tune upon the heartstrings. When you launch your boat—or canoe—from any point along its course and travel quietly along, it's like moving through a place foreign to 20th century life. The Suwannee kept its glory and somehow escaped the progress that has destroyed so many streams across America. It was this atmosphere, this vision bred by the Suwannee, that stirred Stephen Foster to write a song which would immortalize it for all time to come. "Way down upon the Suwannee River . . ." those words have a downhome ring that makes one dream of the peaceful solitude to be found here.

It was on an April day—perfect for experiencing the Suwannee—that my family and I first launched our small runabout boat upon the river at Old Town's KOA campground. Nestled back in a huge grove of live oaks near a sweeping bend of the river, the campground provided us with a beckoning

vista that left us spellbound. We set the boat adrift and let it lazily move downstream with the current before starting the engine and motoring slowly upstream.

Great wading birds arose, squawking their displeasure as we moved into view. Alligators slid from the banks and disappeared under the waters. Snakes lay sunning and refused to move unless we approached too closely. A squadron of black buzzards circled overhead and occasionally a bass leaped from the waters.

The Suwannee runs slowly and meanders, its black water feeling its way between soft white sand banks and rocky shores, choosing an uncertain path at times in the low cypress swamps that crowd close to each side. And along its path are great blue-water springs that emerge from the forest to flow sweet, cold and fresh, adding new dimension and great drinking places to any boating or canoeing experience along the river. The sandy bottoms of the springs, some of them 40 feet deep, are carpeted with watercress and other edible aquaplants. You can glide above them in water so crystal clear it's almost like flying. You can count the fish, or see an occasional turtle and sometimes a manatee or a sea cow during the winter months.

Just over 225 miles long from its source in the brooding Okefenokee Swamp, on the Georgia-Florida boundary, to its meeting with the Gulf of Mexico on the great convex bend of Florida's west coast, the river flows through largely isolated country



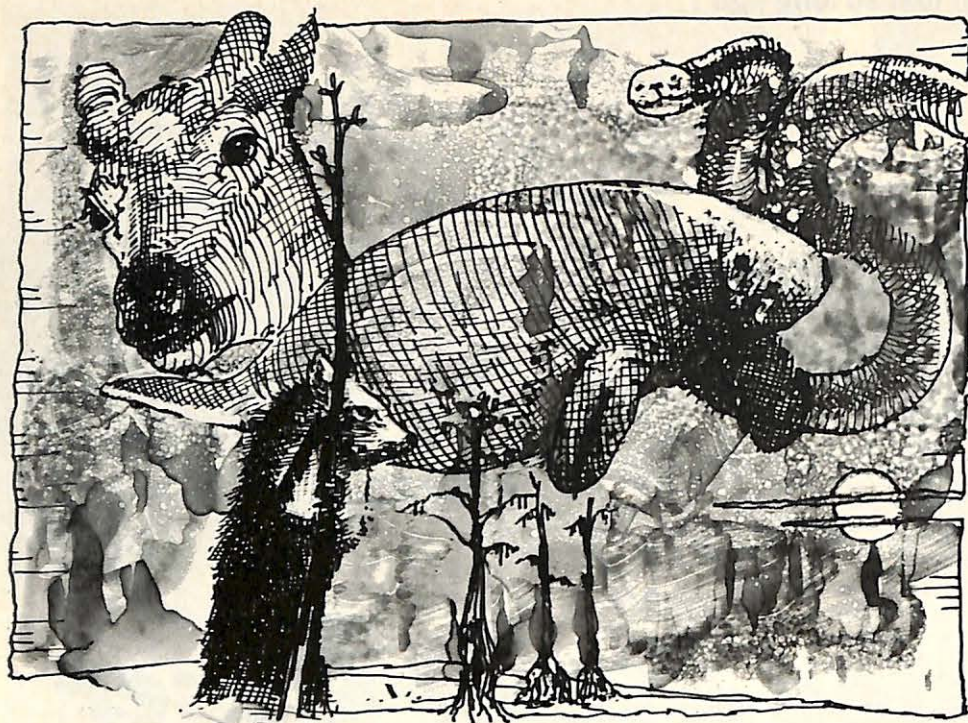

wealthy in the tradition and history of another era. Today, it passes less than a dozen towns on its journey—all with less than 1,000 population each—and most of its territory is as wild as it was during the days when the Seminoles and Creeks held sway before Columbus discovered the New World.

If there is a single river that is most representative of the deep South, it would have to be the Suwannee. Foster wrote about it—even though some historians claim he never saw it—because the name to him possessed a romantic mystique and because of descriptions given him by people who had seen the Suwannee. It was a lazy stream, in keeping with the land and the pace of life one imagined of the deep South. A stream that ambled through dense groves of live oak draped with Spanish moss, past swamps and great clearwater springs. Cypress crowded close along its banks, common egrets and great blue herons fed along its periphery, alligators and cottonmouth snakes bathed on the sandbars or in the shallow waters of adjacent swamplands. Foster was right—the Suwannee River indeed was a romantic southern stream. It still is.

The Suwannee is one of the two rivers within the Okefenokee Swamp. The St. Mary's flows generally southeast to lose itself in the marshland estuaries of the Atlantic near Cumberland Island just north of Jacksonville, FL. Remarkably, it is one of the great rivers on earth that has been little influenced by man or progress.

During the time Foster wrote about it, a number of plantations had been developed along the upper Suwannee; but many later failed, for one reason or another. And today the Suwannee,

along at least two-thirds of its course, has all the appearances of a wilderness stream. It is so natural and pristine that in 1968 the Wild and Scenic Rivers Act recommended that the entire river be considered for addition to that system. Controversy ensued, however, and the issue still has not been resolved.

Originally, the Suwannee had a Spanish name—*San Juan-ee*, meaning Little St. John's. The St. Johns River flows north through Florida not far away to the east. Colloquialism changed that to Suwannee over a period of years, however, and few people today could imagine it being known by any other name. Foster misspelled it—Swanee—but historians say he did so because he consulted an atlas in which the name was also misspelled.

Enroute out of the Okefenokee, the Suwannee flows through a chain of beautiful emerald lakes—Big Water, Minnie and Billy's—all formed during dry periods when the peat bottom of the swamp dried out and actually caught fire, creating vast depressions. These later filled with water and are now lined with bonnet lilies, golden club and bladderwort. The river also winds through natural channels created by large islands that provide a home and dry land for deer, black bear, bobcat, alligators, raccoons, opossum, wild turkey and, some say, the endangered Florida panther. American bald eagles are sometimes spotted along its watery way diving for fish.

Along the river's route nests the white ibis in huge flocks in early spring. The cypress trees are overburdened with their weight as thousands upon thousands of birds gather to raise their young. But the swamp is alive with

wildlife. Once we canoed that portion of the Suwannee with an old friend and fellow photographer, Wendell Metzzen, who is also the wildlife biologist on the Okefenokee National Wildlife Refuge. The Okefenokee and the Suwannee are magical places to both of us, for we find here not only great numbers and diversity of wildlife, but breathtaking beauty.

On the Suwannee's journey, its spongy banks sometimes melt away, and the river for a time becomes part of the vast wetland surrounding it. But in periods of drought, water is found only in 'gator holes and in the main channel of the river. The Suwannee has been dammed just as it is about to leave the Okefenokee to maintain a stable water level in the swamp. But at no other place along its course has its water suffered impoundment.

In north Florida, the river tumbles swiftly over shoals and boulders between high limestone banks, topped for miles with thickets of cedar. At some time in the past—mostly around the turn of the last century—thousands of cedar logs were cut along the river and floated to market. Other trees and masses of underbrush in the valley change with the seasons, shading from pale greens through yellows and reds to dusky brown, but the cedars remain much the same year around. Bass, perch, catfish and bream are found in small numbers in the river, and small game is plentiful along its banks.

One fish is found nowhere else. It's the Suwannee bass (*Micropterus notius*), which exists only in the Suwannee watershed. First recognized as a species in 1949, the fish seldom exceeds 12 inches in length, but it reaches an average of about two pounds in weight. It has a small mouth, is dark in color and exceeds, some claim, the fighting finesse of its cousin, the smallmouth bass. It's an interesting fish, but due to its scarcity, few fishermen ever spend time looking for it.

At many places, the coffee-colored waters are trimmed on each side by a narrow ribbon of pure white sand, particularly during low water. And during these dry seasons in the upper reaches, the low water reveals limestone strata sculptured into fantastic formations by erosion over the centuries. Here the slow current fixes swirling patterns upon the dark surface of the water, broken only by the occasional roll of the great catfish. Along its entire course the Suwannee drops on the average less than six inches per mile. So if you're taking a canoe trip, don't expect to run into any stretches of whitewater rapids.

The dark color of the water originates in the Okefenokee, where the trees and decaying vegetation release



a, chemical called tannin into the stream. Tannin in excessive amounts can sterilize water and limit the growth of microscopic life which, in turn, has a detrimental effect upon higher forms of aquatic life. Consequently, the Suwannee is not, and never has been, a great producer of fish.

Many of the rivers of the deep south, and particularly those of Florida, are born or are supplemented by great springs. We came across a number of spring runs as we boated along. Occasionally, we glided into them, choosing our way along a course so narrow that sometimes we had to take double-hitches at making the turns in the stream. But they were great places to explore, and some of them appeared as though we were the first intruders to come this way.

The springs are important to the Suwannee. They provide waters largely free of tannin, and thus a different type of ecosystem develops. As the spring water enters, the blackwater of the Suwannee fades. And then other tributaries—the Santa Fe, the Withlacoochee and Alapaha—join to broaden the Suwannee to a formidable width.

The springs themselves are most interesting, for they are among the largest to be found in North America. Manatee Springs near Chiefland, FL, for instance, rises from a bowl and

pours more than 49,000 gallons of water per minute into the Suwannee. Up until the 1940s, the manatee frequently came up the river to the springs, thus its name, but rarely do they visit now. The sea cow, as they are sometimes called, an endangered brackish water species, resemble in some ways a sea lion or dolphin. They are docile and harmless. Ranging up to 10 feet in length and up to 1,200 pounds, they are quite slow-moving. Because of this sluggishness, their chief enemy is the power boat which runs over them, slicing them up with its spinning propeller. So one must always—as we were—be constantly on the alert for swimming manatee. They are mammals and must come to the surface every eight to twelve minutes for air. The rest of the time they spend on or near the bottom of the stream.

Marine biologists estimate there are fewer than 100 manatee left in U.S. waters, although they once were so numerous they were found all the way from the Carolinas to Texas. Now they are only in Florida waters. They frequent the springs because of the warmer water temperatures in winter and because of the lush vegetation for food.

But there are other interests in springs, too. Near the town of Bradford, FL, is deep Blue Troy Spring. On the bottom of the spring can still

be seen a sunken Civil War gunboat.

Along the east bank of the Suwannee, five miles from Beel, is Rock Bluff Springs, surrounded by enormous cypress trees. Near Old Town is Fanning Springs. Not all the springs belch water from the earth. Some are so laden with iron they are orange and their waters smell of sulphur. Along their run for the Suwannee, they deposit spongy masses of ironlike scum upon the landscape. No aquatic life lives here.

For several days we boated up and downstream out of Old Town, and soon the pace of the river began to penetrate the very fiber of our character. We became docile, easy-going, carefree . . . and lazy. We meandered almost as the river. We became different people, and the pace of life we had known before we came to Old Town and the Suwannee seemed as foreign as snow and ice would have been here in the deep south.

Numerous places are available to launch your boat along the river, most of them free of charge. And you can boat anywhere you please, for the Suwannee is an inviting stream. The closer to the Gulf you get, of course, the larger it becomes, its banks more remote to the ways of river life and experience. But it is a fascinating stream which provides a unique and colorful boating experience. ■



## THE JOY OF GIVING

Elks National Foundation  
2750 Lakeview Avenue • Chicago, Illinois 60614



Heart-shaped tokens commemorating Greece, NY, Lodge's 50th anniversary were presented to National Foundation contributors recently. Immediate-PER Robert Sutorius (seated, left) and his family were the contributors. (Standing, from left) Robert Sutorius, his fiancée, Collen O'Malley, Barbara, Stephen, and Mrs. Rose Sutorius (seated) gathered to receive their certificates.



The title of honorary founder was earned by Brother Paul Thomas (center) of Vallejo, CA, Lodge recently. Chm. Al Robinson (right) congratulated Brother Thomas for fulfilling his \$1,000 pledge to the National Foundation. ER Bob Perry presented a pin and certificate to the contributor.



Grand Trustee Frank Garland (center) presented seven honorary founder's certificates to contributors at Bremerton, WA, Lodge recently. ER Harry Singer (left) and SP C. J. Hauge (sixth from left) joined Brother Garland in congratulating (from left) Chm. Charles Titus, Frank Honso-wetz, Mrs. Frank Lockwood, PER Harry Schlabach, who received certificates for his donation and for that of the PER Association, Francis Kae- ser, and Theodor Miller.



# MAJOR PROJECTS

*This is part of a continuing series on the state major projects. All state chairmen have been contacted by The Elks Magazine and have been asked to forward information for upcoming articles.*

Flexibility is a key feature in the development of **South Dakota's** major project. The project's goal has been to help children throughout the state. Its progress has included changes in approach, reorganization of the work force, and the traverse of countless miles across the state.

The South Dakota major project dates back to 1934 when the state association provided funds to help operate the state health department's screening clinics for children. The clinics determined which children were in need of physical therapy. This operation was soon expanded to include the treatment of children who needed therapy and for whom no therapy services were available in their home communities. In 1970, the Crippled Children's Hospital and School in Sioux Falls requested assistance for a traveling rehabilitation unit. The state association came to their aid and assumed responsibility for funding the program.

The need for mobile help increased, particularly among infants and small children. And so, in 1976, the South Dakota Elks revised their major project once again: the traveling rehabilitation unit was expanded into a program called Evaluation and Planning for Infants and Children (EPIC) Outreach. EPIC Outreach currently concentrates on children five years old and younger who are physically or developmentally handicapped. The nature of the children's needs is determined through comprehensive evaluations at the Crippled Children's Hospital and School. The evaluations are funded by school district placement committees. After the evaluations, the children are referred to EPIC Outreach.

The staff of EPIC Outreach is comprised of full-time professionals, including speech, physical, and occupational therapists who are members of the evaluation section of the Crippled Children's Hospital and School. They conduct evaluations and implement therapy programs in the children's homes or communities. While operated and staffed by the Crippled Children's Hospital and School of Sioux Falls, EPIC Outreach utilizes the services of Elks volunteers for nonprofessional aspects of the project. The local Elks aid the professional staff in conducting therapy sessions in communities where the Elks facilities are needed.

The value of home therapy for children in remote areas is inestimable. Eric, a young victim of both cerebral palsy and epilepsy, risked serious injury by being unable to coordinate his movements

quickly enough to stop himself from falling. As a result of the EPIC Outreach program, he is now able to prevent himself from falling and continues to improve.

The success of home and community-based therapy programs affects not only the children treated, but also the parents involved. They appreciate the support offered by the visiting therapists and the instruction concerning their day-to-day role in their child's treatment. The therapists try to help parents understand their child's problem so progress can be a family-felt victory.

EPIC Outreach receives the cooperation of school districts, the State Department of Education, the State Department of Health, public health nurses, and family physicians. Records are kept by the Crippled Children's Hospital and School.

Funds for the mobile unit are provided by South Dakota Elks. Part of this money comes from an annual assessment of one dollar per member. The remainder is provided by the interest earned on the South Dakota Elks Charitable and Welfare Trust. All lodges in the state of South Dakota participate in providing funds for the trust, and all funds from the trust are used in support of the major project. To date, more than \$300,000 has been donated by the Brothers for use in EPIC Outreach. Planned expenditure for the major project for 1979 is \$34,000 and will include the purchase of a new mobile unit.

The Elks of South Dakota have found that through mobility they have been able to bring necessary therapy to handicapped children throughout the state. With the many changes and improvements which the Elks have initiated in their major project, they have utilized innovation and flexibility—elements which have been instrumental in broadening the opportunities for Elks to help those in need.

The need to cooperate is something **Oklahoma** Elks recognize as an impor-

tant facet of their major project. There are five different areas with which the Brothers are concerned, and their work in each involves cooperation with community or state organizations. The success of the project depends on the interaction between the state association and these organizations as well as on the dedication of both parties.

One section of Oklahoma's major project is the co-sponsorship of the Oklahoma Highway Patrol Cadet Lawman Academy. The brothers work with the state Highway Patrol's safety education division in organizing and funding a one-week training course designed to promote a better understanding of law enforcement. The school is held in June at the former Clinton-Sherman Air Force Base in Burns Flat, Oklahoma.

Students of the course are young women and men who are juniors going into their senior year of high school. They must be in the top half of their class scholastically and physically able to participate in all the activities. A physical examination is required before entry into the program, and each youngster must be endorsed by a school official, a law enforcement official, and a lodge. Belief in the Elks' principles of law and order and service to God and humanity is also a prerequisite to acceptance into the program. Each lodge in the state may enroll two cadets in the course every year. The Highway Patrol assists the lodges in the selection of the students.

The challenge of learning various aspects of law enforcement adds excitement to the training process. Firearms training, self-defense, judo, and defensive driving tactics are skills introduced to the cadets. Subjects investigated in class sessions include history of law enforcement, jury duty, laws pertaining to arrest and use of radar and aircrafts, and the dynamics of lake patrol. Responsibilities of the citizen is also a topic explored during the one-week stay at the academy. Qualified instructors from the Oklahoma Bureau of Investigation and the FBI join state elected officials and highway patrolmen in teaching the youngsters. In addition to the training sessions, the cadets tour Altus Air Force Base and visit Granite Reformatory.

Although there is a lot to learn in one week, the cadet's days are arranged to allow some time for swimming and other forms of recreation, such as baseball and tennis. Meals are taken in a modern dining room in which there are tables for four youngsters. Seating is changed regularly to encourage interaction among everyone.

*(Continued on page 31)*

PGER Francis Smith and SP Charles Gaeckle join major project therapists.





## You and Retirement

(Continued from page 11)

investment in exchange for the right to sell more distributorships. There are not enough people in the world to fill the number of distributorships necessary to make a profit under most such arrangements. Legitimate companies emphasize profits from the sale of products.

⊙ Ask the company what kind of training you will receive. Most companies place new salespeople under the wings of experienced people; many offer formal training sessions as well. World Book, for instance, has fifteen hours of training and suggests that no commitment be made until a prospective salesperson sits in on one or two sessions.

⊙ Find out whether you will be assigned to a territory or will have free reign. Can you call your friends in the next county? Your relatives back home? Or will that territory "belong" to someone else? Will you have to travel, conversely, when you'd

rather not? Policy differs from company to company; be sure you know the ground rules before you start. Find out, too, whether your community requires that you be licensed before you sell.

⊙ Will you have to make a quota? You'll want to set your own goals but it's best to know, in advance, if the company has requirements which must be met.

⊙ Be sure that the company stands behind its products and that you will not suffer a personal loss if a customer is dissatisfied or if you, for any reason, have to stop selling. Amway, for instance, will buy back any excess inventory.

Legitimate companies have a major investment in product development. They buy national advertising to support their local sales force; you'll find such advertising a big help in securing product credibility. Legitimate companies also subscribe to the code of ethics of the Direct Selling Association. If you have any questions about a particular company, contact the Direct Selling Association and/or your local Better Business Bureau. ■

## Medicine and You

(Continued from page 15)

need not be the unsightly thick "bubble glasses" of former years. A wide choice of frames is available to suit personal taste and the dictates of fashion, although certain extra-large frames are not recommended.

Aspheric lenses are often prescribed; with these (which vary slightly from a true spherical curvature), power gradually decreases towards the periphery of the lens to reduce distortions that can occur in the high-power lenses needed by cataract patients. Aspheric lenses, like most others, can be made of either glass or plastic.

The choice of lens material for cataract glasses should be discussed with the eye care specialist, as each case is different. Patients should know they have a choice of lens material and should consider all the pros and cons.

The special cataract glasses were the first (and are still the most frequently prescribed) post-surgical visual aids de-

veloped. Then came hard—followed by soft—contact lenses. These provide better peripheral vision and produce less distortion than the eyeglasses. But for the elderly or infirm, they may be difficult to insert and clean.

Perhaps the biggest improvement in cataract surgery is the increased use of the technique that involves implanting a tiny plastic lens in place of the clouded and opaque lens that is removed from the eye during surgery. For about 50,000 carefully selected patients a year, these "built-in spectacles" offer an increasingly popular alternative to eyeglasses.

These intraocular lenses were developed about 10 years ago. They have since been refined so that now they come in a variety of designs and powers that can also correct other vision problems like near- and far-sightedness in the cataract patient. However, these lenses are not without their problems. Critics say they can slip and cause eye damage.

In deciding the best type of surgery for you, do consult more than one doctor. And remember that today, cataract surgery is common and incredibly successful. ■

## It's Your Business

(Continued from page 18)

about the volume of paperwork—the red tape—on the private sector. We're carrying on the usual function of legislation and testimony, and we're also involved in regulation and what effect it has on the private sector. A president needs that sort of guidance.

"But I see nothing unusual about businessmen being critical. Most businessmen are Republicans and this is a Democratic President; and then too, business doesn't like interference and regulation . . . they'll criticize any administration, depending on how the decisions affect them."

Finally, what about the complaint among small business people that their views aren't being heard in an administration headed by a one-time small business proprietor? "I know the President is meeting with more and more small business people," Dietsch insists. "I can tell you in the Office of Management and Budget the director has had a whole series of meetings with small businessmen and minority business persons. There's a natural tendency for any group to think it's under-represented or not heard. But I think that today small business is adequately represented in Congress, and I think that the administration is hearing the views of small business."

"I don't believe the small businessman is going to be ignored . . . nor will the small businesswoman either." ■

# Florida

From only \$23,900 on Florida's Atlantic Coast there is beautiful lake country where you can retire on a sensible budget in an adult community of doublewide mobile homes. Phone Toll Free 1-800-237-9494 for more information or Fill out coupon below.

MAIL TO: VILLAGE GREEN  
Dept. 370 3P.O. Box 2823,  
Vero Beach, FL. 32960

Name \_\_\_\_\_  
Address \_\_\_\_\_  
City \_\_\_\_\_  
State \_\_\_\_\_ Zip \_\_\_\_\_  
Phone \_\_\_\_\_

## VILLAGE GREEN

at Vero Beach / A Lakefront Community  
of Distinctive  
Mobile Homes



### SAVE HUNDREDS OF DOLLARS

Possess the gem that's as brilliant as a diamond.

The incredible MAGIC FIRE™ has more "fire" than a glittering natural diamond. Own the dazzling impact of diamonds that can easily sell for up to \$1,000 per carat — for a fraction of the cost. From \$35 — All settings in 14K Solid Gold. Send for our FREE catalog of pendants, earrings, and rings for men and women. Credit cards accepted.

### MONEY BACK GUARANTEE

Easy Payment Plan Available

The Crown Collection Dept. EL-79  
509 Madison Ave, NY, NY 10022

# BINGO

## FOR PERMANENT FUND RAISING

Easy way to raise money for your Organization because everyone has fun playing BINGO! Thousands of Organizations are making up to \$500.00 per week using "BINGO KING" supplies and FREE Idea Bulletins. Write for FREE catalog and details on raising money for your Organization.

PLEASE GIVE NAME OF ORGANIZATION.

'BINGO KING'  
DEPT. EL-79, BOX 2499, LITTLETON, COLO. 80161



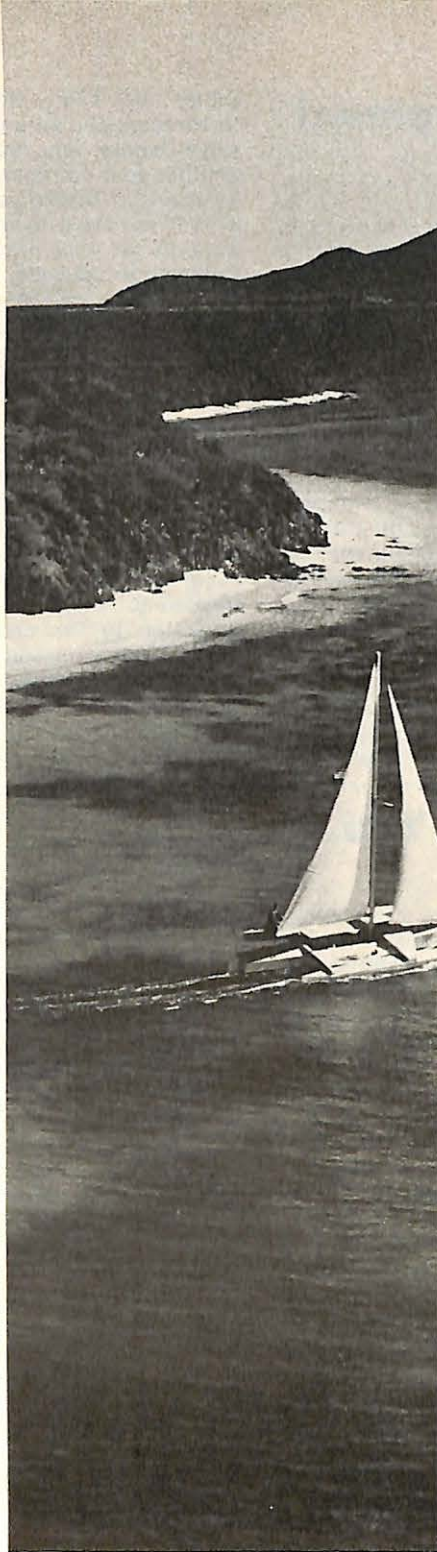

# Turn Off The World On A Caribbean Island

**A**s an old island hand I must tell you about St. Lucia, a bit of heaven that floats in the Caribbean just a sigh from Martinique. As islands go it is small (27 miles long, 14 miles at the widest) but devilishly green and breathtakingly beautiful. Yes, and even a bit unspoiled. Clouds hang on the horizon and jungles sweep from volcanic peaks and hillocks to the sea, and in places the growth is so thick that day becomes night in a rather eerie way.

by Jerry Hulse



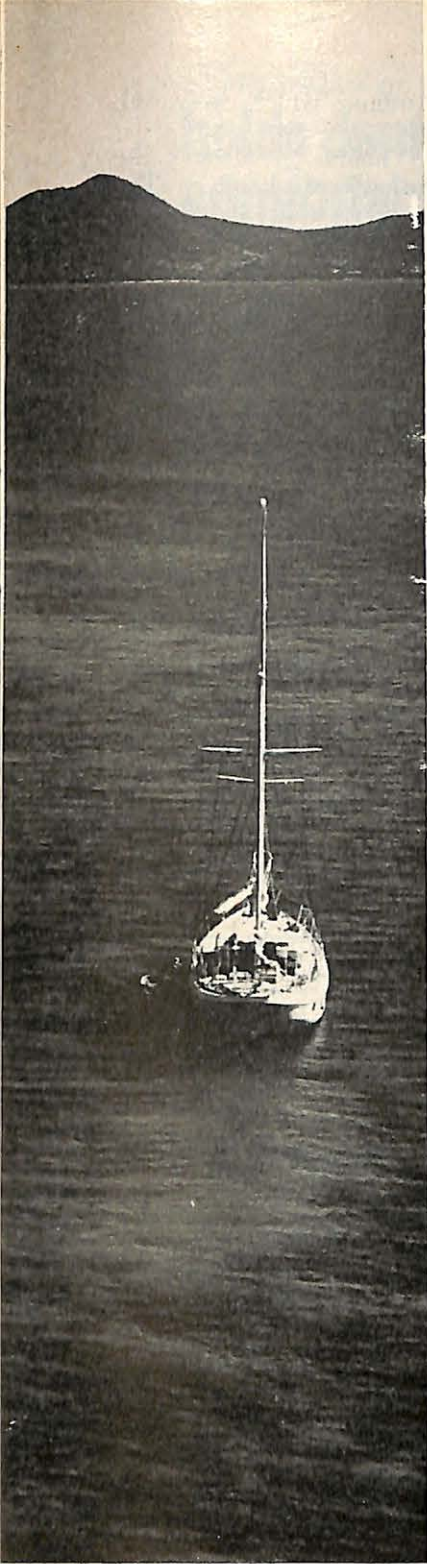

**Whether you dive for sunken treasure or water-ski across a rainbow-colored lagoon, the Caribbean, with sun, sea and sand, can divorce you from the cares of a sometimes frustrating world.**

When I arrived one evening recently it had been raining and the headlights of an ancient taxi stabbed the darkness and steam rose from the pavement. Wheezing as if to collapse, the taxi bumped along through the night. Deftly, the driver dodged pot holes and the fallen branch of a tree.

He spoke with the softness of the West Indies islander.

"Hot, suh, very hot tonight."

"Feels good," I replied.

"Your first visit here?"

I nodded.

He smiled. "Oh, you'll find this a beautiful island. Yes, suh, a most beautiful island."

At a junction he switched to another road. It was filled with still more pot holes. Finally we saw lights glowing from Anse Chastanet, one of St. Lucia's proudest resorts. Anse Chastanet provides 21 doubles in octagonal rooms with electric fans spinning in the ceiling, while breezes flow through the windows so that air-conditioning isn't required.

The units are strung up a hill that overlooks a striking black sand beach, and at night guests are lulled to sleep by the sound of the surf and the symphony of singing frogs. A couple of peaks, the Pitons, rise heavenward like those on Moorea. Indeed, there's a feeling here of the South Seas. And like resorts in the South Seas, Anse Chastanet is a place to come to rest. There is little else to do but read, sun, swim and meditate. And what's so bad about that?

Anse Chastanet, like the rest of St. Lucia, exudes a friendship and informality that puts one at ease. Like its guest quarters, the dining room at Anse Chastanet is open and octagonal. The dinner menu makes mention of sauted sausage, pumpkin, yams, mango ice cream and other selections, many of them creole. A stairway leads to the beach where barbecue buffets are featured along with West Indian soups and salads.

The resort is operated by a couple of Canadians, Wayne Brown and Nick Troobitscoff, who ran off to the Caribbean to escape the northern freezes. Off-season rates (April 16 through December 14) are \$39 single and \$64 double.

And then there is Dasheene, one of the slickest hideaways in the entire Caribbean. Perched on a hilltop dead center of the Pitons, its 16 condominiums are without walls—on the ocean side anyway. It's a trip, a shocker, and with one of the loveliest views on earth. Guests seated in the living room lean back and relax, staring out the missing wall. Between them and the sea there's

nothing, absolutely nothing. Just space. And in case someone gets hooked by the view out the missing wall, the apartments are on sale starting at \$15,000. Drop a line to Lionel Couture, c/o Dasheene, Soufriere, St. Lucia, West Indies.

Between here and the capital city of Castries the land is strewn with coconut palms, bread fruit and nutmeg trees, coffee plants, banana plantations and a tangle of jungle vines. Goats and pigs cross the road at will, all of which makes for a bit of skillful driving.

Above the colorful, tin-roofed town of Castries, ex-RCA executive Len Headley and his wife, Pat, have created a string of fashionable apartments in a building formerly occupied by British civil servants. Called Top O' the Morne, the apartments provide a moving view of the harbor below and Martinique on the horizon. At any rate, Top O' the Morne makes for some splendid viewing. With an even dozen apartments, high season tariffs range from \$32-a-day for a studio to \$56 for a two-bedroom unit. Each apartment comes with a fully-equipped kitchen. The Headleys toss in a rental car for another \$99-a-week, with unlimited mileage. For details, write to Top O' the Morne, P.O. Box 376, St. Lucia, West Indies.

From the Headleys' place it's only five minutes to a splendid restaurant, the Green Parrot, which is operated by a St. Lucian named Harry ("Don't ask my last name," says he) who has built himself a reputation as the island's No. 1 chef. He likes that handle: Chef Harry. Harry is a singer to boot—his theme song being "Yellow Bird"—and once in England he loosened up the vocal cords for Princess Margaret. This occurred while he was learning about souffles and such at Claridge's where he was hired on as an apprentice chef. Besides turning out some of the best creole cooking on the island, Harry has built himself an inn next door. The cost for board and room starts at \$50-a-day.

Others take their meals at a romantic old pile down on Columbus Square called Rain. And indeed it does conjure up memories of naughty Sadie Thompson in Somerset Maugham's classic tale of a debauched female shifting for herself on another green island. A picture of Joan Crawford who played Sadie in the film hangs on one wall. It's the sort of place you would expect to bump into Richard Widmark (or Bogie when he was alive). Customers line up downstairs at a six-stool bar, their images reflected in an old-fashioned Coca-Cola mirror. In keeping with the mood of the place, someone spins a dated record and the words



# Caribbean

spill forth. Waiters lead guests upstairs to the balconied dining room with its hurricane lamps. And as if on cue, the rain came this recent night in torrents, and outside on the street islanders walked barefoot through puddles, unmindful of the downpour.

Then there is the island of Antigua with its 365 beaches or one for every single day in the year. They run the gamut from small wedges of talcum to others skirting the coast for a mile or more. The one at Half Moon Bay stirs the hearts of all ambitious sun worshippers. Up the coast the beach at Hyatt Halcyon Cove is particularly inspiring. A sign tells the sunbather the distances between the island and various cities and capitals. (At 570 miles, Caracas is the closest.) As for the beach, it sweeps downcoast all the way to Runaway Bay, which in turn spends itself somewhere on the horizon. The Hyatt is where the action is. It's run something like a Club Med. It doesn't cost a single Antiguan cent, for example, to water ski or to sail or to take a turn on one of the paddle boats. Out to sea, there's an over-water dining room for the noontime crowd. Of an evening guests take their meals at a hilltop restaurant that's reached by tram. All this makes for a spectacular scene at night with lights strung along the coast and the Milky Way overhead. Financially, it's best to arrive in the off season when there are all the frills but the price is right—\$42 to \$47-a-day.

One of the cheapest offers on Antigua comes from the Barrymore Hotel, a mom 'n' pop operation only five minutes from the sea and a short jog from St. John's. Even high-season rates are only \$36 (single) and \$58 (double) including both breakfast and dinner. It's the best bet in Antigua if you don't mind being off the beach. And even if you do, the hotel operates a free shuttle to Dickenson Bay. Elegant it's not, spotless it is—with that same feeling of adventure one experiences at Aggie Grey's in western Samoa.

And then there is Blue Waters, a spick-and-span resort on the very northern tip of Antigua. While the beach is

narrow, Blue Waters provides huge helpings of atmosphere. It's a peaceful enclave consisting of 47 rooms and a couple of garden suites spread across meticulously manicured grounds. Barbecues are staged Tuesday and Friday at Blue Waters, a steel band performs on Saturday and there's dancing to a conventional live band on Tuesday.

At the opposite end of the island others put up at English Harbour, which served for more than a century as Caribbean headquarters for the British Royal Navy.

It was here that Horatio Nelson stood off French and Spanish fleets in a series of skirmishes during the 18th century. Afterward he sailed off to nip the enemy in the Battle of Trafalgar. Admiral's Inn faces a harbor crowded with charter yachts ("Sail away for a day, a week, a lifetime...") and the lofty peaks of Shirley Heights with its crumbling fortifications. Only a few steps away, workmen have concluded converting Admiral Nelson's ancient copper and lumber store into one of the niftiest inns in the entire Caribbean. It's up to its beams in atmosphere—a dozen luxury apartments sheltered inside the old Georgian building. Family vacationers give it raves. Units complete with bedrooms, sitting rooms, kitchens and baths are provided. For this, the weekly rate during the high season adds up to \$250 for doubles and \$400 for the larger family units. For details, write to Ted Stevens, Box 1283, English Harbour, Antigua, West Indies. (Stevens can also furnish information on yacht charters.)

The Caribbean is where tourists go to do their thing. And their thing could be anything from the limbo to diving for lost treasure or water skiing across a rainbow-colored lagoon. St. Thomas in the U.S. Virgin Islands is where the big cruise ships tie up. It's the jumping off place to other islands.

Roughly 100 islands, islets and cays are scattered throughout the waters of the American and British Virgin Islands. And then there are others: St. Martin, St. Barts, St. Kitts, Nevis, Guadalupe, Montserrat, Dominica, Martinique, St. Vincent Barbados, Grenada, the Grenadines, Tobago, Trinidad, Haiti, the Dominican Republic, Jamaica, the Cayman Islands, Aruba, Curacao, Bonaire and, of course, St.

Lucia and Antigua which we've already discussed.

As for St. Thomas, it attracts the shoppers—thousands of shoppers. The reason, of course, is that St. Thomas is the major duty-free stop in the U.S. Virgins. Those shopping bags are bulging with Thai silks, Swiss watches, Japanese pearls, German cameras, Italian knits, Bally Amalfi shoes, Metzger shirts and other snappy clothing with names like Pierre Cardin, Christian Dior and Givenchy. Stores line both sides of Main Street. Other roads reach to the waterfront. In St. Thomas it's Christmas year-round, with a duty-free allotment of \$600 rather than the customary \$100 limit elsewhere in the world. (This is because the U.S. Virgins belong to Uncle Sam.) Regular air shuttles run seven days a week between St. Thomas and San Juan. It's a 20-minute hop.

In the Caribbean some resorts play a game of turning off the world. No telephones, no radios, no television, no newspapers. Just sun, sea and sand. It's a hedonistic society totally divorced from our sometimes frustrating world. At one resort I visited, a young lady arrived carrying nothing but a handbag. Stuffed inside were three bikinis. It was all she brought. Wasn't this enough, she asked?

Well, that's the Caribbean—free 'n' easy. Just pick an island, forget your cares... and relax. ■

## Departed Brothers

**PAST DISTRICT DEPUTY** Alfred W. Pierce died April 16, 1979. A member of Mountain Home, ID, Lodge, Brother Pierce served the South District as District Deputy Grand Exalted Ruler in 1969-1970.

**PAST DISTRICT DEPUTY** John H. Sibold of Lewisburg, WV, Lodge died March 24, 1979. Brother Sibold was District Deputy Grand Exalted Ruler for the South District in 1961-1962.

**PAST DISTRICT DEPUTY** Curtis A. Hill of Lawrenceville, IL, Lodge died April 20, 1979. In 1954-1955, Brother Hill was District Deputy Grand Exalted Ruler for the Southeast District.

**PAST DISTRICT DEPUTY** Earl M. Buckley died April 24, 1979. A member of Gulfport, MS, Lodge, Brother Buckley held the position of District Deputy Grand Exalted Ruler for the South District in 1959-1960.

**PAST DISTRICT DEPUTY** Nathaniel B. Harrison of Gardena, CA, Lodge died April 27, 1979. In 1964-1965, Brother Harrison served as District Deputy Grand Exalted Ruler for the South Central Coast District.

### FIND BURIED TREASURE

Find buried gold, silver, coins, treasures with powerful new electronic detector. Ultra sensitive. Penetrates deep into earth. Works through mud, beach sand, rock, wood, etc. Signals when object is detected.

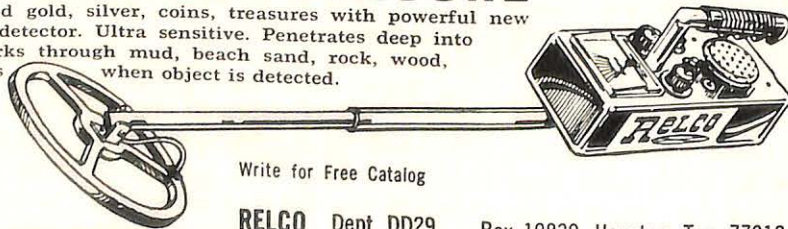

Write for Free Catalog

RELCO Dept. DD29. Box 10839, Houston, Tex. 77018



No paste or powder  
**holds dentures  
comfortably tight  
for weeks** like Snug  
Denture Cushions

Not a messy paste, powder, cream or wax pad—but an amazing soft plastic adhesive cushion. Snug® Brand Denture Cushions hold loose, wobbly dentures comfortably tight for weeks. With Snug there's no need to bother with messy daily "fixing." It lasts for weeks, sticks to your plate not to your gums, so easy to clean or remove. Get Snug Denture Cushions to hold your dentures tight and firm for weeks...in comfort. At all drug counters.

# BINGO

Largest Manufacturer  
and Distributor of  
BINGO Supplies

Free Catalogues available for:

- ★ Complete bingo supplies
- ★ Tables & chairs
- ★ Flags & banners
- ★ Armchair races
- ★ Jar & breakopen tickets

ALL STAR BINGO INC. Dept. E7  
P.O. Box 346, Rockville Centre, N.Y. 11571  
Toll Free Call: 800-221-6706



## JOKES FOR SPEAKERS!

Topical Joke-Bulletin with approx. 100 funny one-liners, stories and roast-lines. Created by top Hollywood comedy writers. Ideal for Business and Club meetings, Banquets, etc. Humorize your speech for any audience; any occasion. Current issue, \$5.00. Send check or m.o. to:

JOKES UN-LTD.  
1357 Miller Dr. Dept. E-6, Hollywood, Calif. 90069

### \* HEARING AIDS \*

From \$89.50—30 Day Trial  
GIGANTIC SAVINGS ON BATTERIES

Write For Free Gift Offer  
and Brochure Today

ELECTRONIC PRODUCTS  
Box 2005-E, Pinellas Park, Florida 33565

REMBRANDT DID IT IN OILS...

Let us do it in  
**BRONZE PLAQUES**

FOR ALL OCCASIONS  
Write for Free Catalog E23  
Engraved Plaques E21

INTERNATIONAL BRONZE TABLET CO., INC.  
150 W. 22nd St., N.Y., N.Y. 10011 212-WA 4-2323



## Japanese Swords Wanted by Collector

**George Nalle**  
203 Colorado Street  
Austin, Texas 78701 (512) 477-6168

### PUBLISHING EXPERTISE WANTED

National magazine in Chicago area seeking magazine generalist. Advertising, production, administration experience, or will train sharp beginner seeking long-term opportunity. Some fraternal background helpful. Reply in confidence to Box 502, The Elks Magazine.

## Major Projects

(Continued from page 26)

When the law enforcement course is completed, both the Highway Patrol and the Brothers hope that the education the youngsters received will provide an understanding of the field and that understanding will lead to a greater appreciation of law officers. The graduates are asked to speak at various school, civic, and youth meetings so that their experience can be shared.

The second part of Oklahoma's major project also demands cooperation between the Brothers and the Highway Patrol. The two groups work together in providing a drug education service. Members of the Highway Patrol visit various school and community groups to present lectures on drug abuse and education. They travel in vans outfitted with slides, films, and projectors and exhibiting the Patrol's and the Elks' emblems. All funding for this operation is provided by the state association.

Two other groups with which Oklahoma Brothers work are the Oklahoma Association for Retarded Citizens and the Cerebral Palsy Training School. Their involvement with the former group entails the co-funding of summer camps for the state's mentally and physically handicapped citizens. There are three camps which operate for one-week terms.

The Cerebral Palsy Training School receives funds from the Brothers for the purchase of needed vehicles and equipment. Oklahoma Elks either provide the total amount needed for a purchase, or they match a donation offered by the Housing, Education, and Welfare Department. A bus with hydraulic lifts, two vans, and a bath system were among the items donated through this program.

The Oklahoma Brothers support the state's handicapped in yet another fashion. For the past three years, they have worked with the Oklahoma Special Olympics. The state association provided all ribbons, medals, and T-shirts, which display the Elks' emblem, for participants of the contest. This particular event provides enjoyment and a feeling of pride for the Brothers as well as the participating children.

The coordination of Oklahoma Elks' involvement in all these programs is the responsibility of 25 directors who are appointed by the SP and the major projects president. Five officers, including a president, two vice-presidents, a treasurer, and a secretary, assist in the administration of the project. Funds for the project's operation are collected through the request for a penny a day from each member in the state. The budget for 1978-1979 totalled \$32,530.

The accomplishments achieved through working with the different community and state organizations are as varied as are the particular aspects of the major project. Through cooperation, Oklahoma Elks can share the success of the Academy as well as that of the Special Olympics. They have the opportunity to extend their aid to many in the state.

## NEVER BUY GAS AGAIN!

CALL FREE  
800-257-7955



### ELECTRIFY YOUR BIKE!

**PEDALPOWER** exciting new bike drive tames tough hills. Be independent. Shop when you want. Fits all Bikes, Adult Trikes. Installs in minutes. Thousands sold. Recharges overnight. Travels 100 miles for a dime.

MONEY BACK GUARANTEE.

Call toll free: 800-257-7955\*

Or send today for

FREE ILLUSTRATED BOOKLET.

**General Engines Co.**

5396 Mantua Blvd.

Sewell, N.J. 08080

\*In NJ, Alaska, or HI. Call Collect: (609) 468-0270

# 30% OR BETTER

**A BOOK ON HOW TO RECEIVE A 30% OR BETTER RETURN ON YOUR INVESTMENT CAPITAL EACH YEAR USING ARBITRAGE IN COMPANY MERGERS.**

5 Years of research are offered to you.

61 Illustrations covering 5 years of actual investments. 8½ by 11 inch 148 page book. **DO IT TODAY—SEND FOR YOUR COPY AND START PROFITING TOMORROW.**

**KAJE Publishing Co., Inc.**  
332 Main St. — P.O. Box 769  
Winner, S.D. 57580

Please send my copy of 30% OR BETTER — If not satisfied I may return the book within 15 days for full refund less postage & handling.

( ) Soft Cover Leatherette \$19.95

( ) Hard Cover \$24.95

Please add \$1.00 postage and handling—S.D. residents add 4% tax.

Please type or print plainly  
Check or money order enclosed for \$ \_\_\_\_\_

Name \_\_\_\_\_

Address \_\_\_\_\_

City \_\_\_\_\_ State \_\_\_\_\_ Zip \_\_\_\_\_



# NEWS OF THE LODGES

(Continued from page 22)



**IN APPRECIATION** of service to the community, Cedar Rapids, IA, Lodge presented a special plaque to Police Chief Gareth Clift (left). Mr. Clift has been a member of the force for 39 years. (From right) Assistant Police Chief James Barnes, chairman of the law and order committee, Mayor Donald Canney, and ER Robert Kacena were on hand to offer congratulations.



**THE BROTHERS** of Manistique, MI, Lodge began a blood bank recently. The first to contribute was ER Gary Traven (left). The bank was instituted to serve all the lodge members and their immediate families.

**TWENTY-FIVE** years after PER Carl Wademan (left) served as Exalted Ruler of Nebraska City, NE, Lodge, he installed his son in the same position. After the ceremony held at the lodge recently, the PER congratulated ER Frederick Wademan (right).



◀ **A PRONE BOARD**, designed to permit variance of position for those normally confined to a wheelchair, was donated to Eugene Field School by Rock Island, IL, Lodge recently. Terry Schlabach (right), occupational therapist, and Sharon Sanyi (second from right), physical therapist, thanked Chm. George Johnson (third) and Est. Lead. Kt. Al Nesseler (left) for the gift. On hand to test the equipment was 6-year-old Levi McGinnis.



**THREE RADIOS**, a guitar, tape deck and stereo systems, and tapes were contributed to the Grove School by Des Plaines, IL, Lodge and the Elks' ladies. The funds were raised through extra performances of a variety show. Presenting the gifts to the school, which is for retarded children, were (seated, from left) Florence Dahm, Mrs. Mize, LaVerne Steuart, Liz Hathaway and (standing, from left) Dave Nelson, Kenneth Cognac, Kima Probst, PER Dave and Marian Seaholm, PER Ronald Sorrentino, Bob Von Schwedler, and Betty and Jerry Wienckowski.





**AN AMERICAN** flag, which was flown over the nation's Capitol, was presented to Storm Lake, IA, Lodge by members of the Disabled American Veterans recently. The DAV holds its monthly meetings at the lodge and offered the flag as a token of appreciation for the use of the facilities. Immediate PER Pete Brown (left) and ER Merle Zillig (right) accepted the gift and a plaque presented by (from left) T. W. Prather, department chaplain, Kermit Siebrecht, Glen Carlson, Larry Flink, and Ken Oleson.



**A CLASS** of 350 new members was initiated into Romeo, MI, Lodge recently. Byron Nichols (left), the first Exalted Ruler of the young lodge, was congratulated by SP William Murray (center). ER Harvey Graham of Rochester Lodge, which sponsored Romeo Lodge, joined VP Edward Kowacik (right) to applaud the occasion.

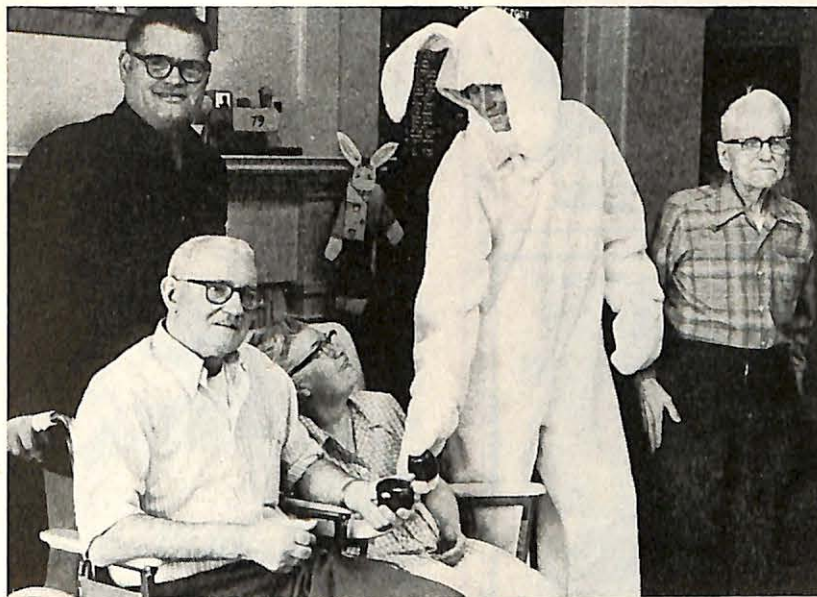

**THE EASTER** rabbit, alias Est. Lect. Kt. Mike Peterson of Rock Island, IL, Lodge, paid a visit to the Rock Island County Healthcare Center. The Rock Island Elks have been bringing gifts to residents of the center for several years. The floppy-eared visitor, accompanied by ER Al Nesseler, gave each resident an apple.



**THE FOURTH** annual Top of the North Award was given to Evanston, IL, Lodge recently. The award recognizes accomplishments in four categories of membership, lap-sation, and support of the National Foundation and handicapped children. PVP Thomas McCreadie presented the award to ER M. William Hurlbutt at the North District Exalted Rulers' Dance.



**YOUNG MEMBERS** of the Sea Explorer Ship No. 541 received awards at the annual Scout-O-Rama recently. The ship is sponsored by Green Bay, WI, Lodge. ER Thomas Mays (right) was on hand for the occasion.



## Carry TEN TIMES a Wheelbarrow Load with INCREDIBLE EASE!

These BIG, strong carts are perfectly balanced on two huge wheels — roll easily over lawns and gardens — carry up to 400 lbs. of load — huge volume capacity means you make fewer trips — you'll save time and steps. If you are still struggling with a wheelbarrow or inadequate cart (with tiny wheels) send for FREE Cart Catalog. Build-it-yourself kits, too.

GARDEN WAY RESEARCH  
Charlotte,  
Vermont  
05445



©1979 Garden Way, Inc.

GARDEN WAY RESEARCH

Dept. 90127

Charlotte, Vermont 05445

Please send FREE CART CATALOG.

Name .....

Address .....

City .....

State ..... Zip .....

# Elks Family SHOPPER

Useful and unique  
new products for  
indoors and outdoors

## COLLECTION OF UNITED STATES STAMPS ALL 50 TO 95 YEARS OLD—ONLY 10¢

Get-acquainted Special—A collection of 10 different old U.S. stamps, each issued at least 50 years ago. ADULTS ONLY Send 10¢ Big lists also included MYSTIC STAMP CO. Dept. E-55 Camden, New York 13316.



## NOW! GET 3 REAL OLD U.S. COINS -- ONLY \$1



You get 2 pre-1938 Buffalo Nickels and a pre-1908 Indian Head Penny. Plus, wonderful price lists Offer to ADULTS ONLY One set per customer. Littleton Coin Co. Dept. SX-77 Littleton, New Hampshire 03561

## STAMP GRAB BAG ONLY 10¢

Giant grab bag of over 100 un-assorted foreign stamps! Africa, Asia, Europe, South Seas, etc Plus wonderful price lists of U.S. & foreign stamps Offer to ADULTS ONLY Send 10¢ to LITTLETON STAMP CO. Dept. G-3, Littleton New Hampshire 03561



BURKE COMFORT FLEX BED features automatic push-button position adjustment & "3 dimensional" total body massage for improved comfort & health benefits. Separate upper & lower body massage units. Timer provides automatic massage shut-off. Free Home Trial. Twin to dual king sizes. Write or call Toll-Free for free color brochure. 1-800-255-4147 Comfort-Flex, Burke, Inc. P.O. Box 1064, Dept. E79 Mission, Kansas 66222

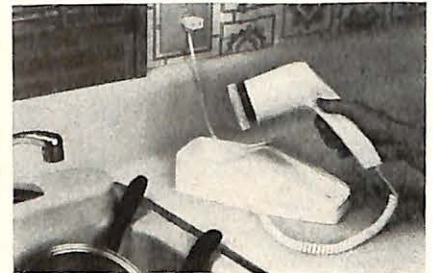

KITCHEN BOON—NEW ELECTRICAL POT-SCRUBBER—"Whirl-away" action scrubs pots and pans completely clean. 3 interchangeable pads take on all cookware scrubbing tasks from toughest cast iron to sensitive teflon. Also for griddles, grills, ranges, ovens, sinks & tiles. Fully warranted. Attractively boxed, with instructions. 10-day return privilege for full refund. \$49.95 + \$3.50 shpg. Check, Visa, Master Charge. H&S Distributors, 2621 Pico Blvd., Santa Monica, CA 90405

## 1000 RETURN ADDRESS LABELS \$1.00

1000 gummed economy name and address labels printed in black with ANY name, address, zip code. Up to 4 lines. Order S717 Set of 1000 Economy Labels (boxed) . . \$1.00

## 250 Self-Stick GOLD FOIL LABELS \$1.98

Gleaming gold foil labels stick to any clean, dry surface—need no moistening. Rich black printing, classic border.

Order P6128 Set of 250 Gold Foil Labels (boxed) . \$1.98

## 250 Self-Stick WHITE GLOSS LABELS \$1.98

Glossy white self-stick labels cling to any smooth surface — no moistening. Sharp black printing up to 4 lines.

Order P6030 Set of 250 White Gloss Labels (boxed) \$1.98

Walter Drake 3297 Drake Bldg.  
Colorado Springs, CO 80940

NAME .....

ADDRESS .....

CITY & STATE ..... ZIP .....

\_\_\_\_\_ S717 1000 Labels @ \$1 each \$ .....

\_\_\_\_\_ P6128 Gold Foil Labels @ \$1.98 each \$ .....

\_\_\_\_\_ P6030 White Gloss Labels @ \$1.98 ea \$ .....

Add 20¢ per set for postage & handling \$ .....

SATISFACTION GUARANTEED Total \$ .....

## INVENTORY ADJUSTMENT SPECIAL!

## PILOT'S GLASSES AT UNBELIEVABLE PRICES!

ONLY  
\$6.95

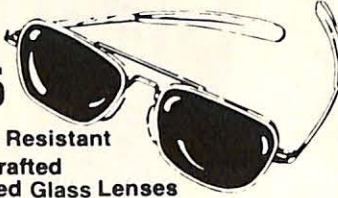

- Impact Resistant
- Handcrafted
- Polished Glass Lenses
- Hardened Metal Frames
- Money Back Guarantee

To order, send check or money order (include \$1.00 for postage and handling) to U.S. Optics, Dept. 314, P.O. Box 14206 Atlanta, GA 30324. (Please specify gold or silver frames.) SPECIAL: Order now and get TWO PAIR for \$13 plus one dollar handling charge.

FREE! During this limited offer.  
Deluxe velour lined protective case. A \$3.00 value.

LIMITED OFFER FROM U.S. OPTICS

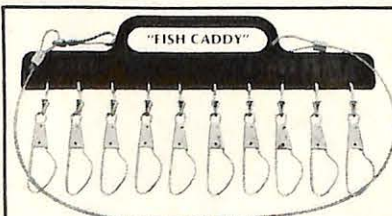

- displaying catch & photographing
- light weight and durable
- measures inches and millimeters
- Price \$5.95 — Postpaid Promptly

PLASTIC MOLDING CO.  
4120 So. 27th West Ave.  
Tulsa, Okla. 74107

## 19 - OFFICERS LAPEL PIN SET

COMPLETE SET  
(Including Assistants)

FREE BONUS P.E.R. PIN



\$29.95  
California  
add 6% tax

Elks Jewelry - Custom Designs - Specials

## EARL BRYAN Club & Fraternal Supplies

9347 Compton Boulevard  
Bellflower, CA. 90706  
213: 666-8417 - Collect

everything  
for your  
lodge





CHILDREN AND ADULTS HAVE FUN with the Belly Board. Inflatable surf mattress has molded skeg keel for complete turning control. Made of special PVC material resistant to punctures, tears or sun, with I-beam construction. Grab lines strong enough to pull belly board thru heavy surf or withstand towing. 42"x18" wide x 3 1/2" thick. Skeg keel 11 1/2" long x 3" deep. Weight 3 1/2 lbs. orange top with blue bottom \$37.00 ppd. L. L. Bean, Inc., Freeport, ME 04033



MAKE YOUR OLD BARBECUE grills & hibaches look like new! Butcher's Black Grill Polishes clean & renew the original black finish & remove and prevent rust. Available in 8 oz liquid bottles & 3.5 oz semi-paste tubes. Non-toxic & non-flammable. Great for woodburning stoves too. Suggested retail price \$1.99. Available at most stores, or write, The Butcher Polish Co., Marlborough, MA 01752

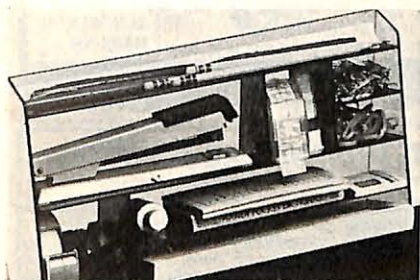

OMNI-FILE™ SUPPLY ORGANIZER—a versatile system for small supplies, held neatly in one place... easy-to-see, easy-to-reach. Slanted shelves keep items from falling out and rounded corners make the smallest item easy to retrieve. Compact unit (9x13x4 inches) mounts simply on cabinets, walls or desk with either screws or adhesive strips (inc.) Molded in rigid plastic. Available in smoke, \$9.95, 2 for \$19.00 ppd. Barrett Technology, Inc., P. O. Box 2096, Sunnyvale, CA 94087

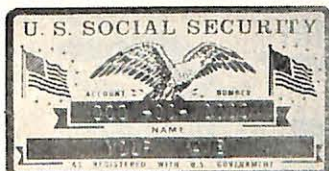

**ATTENTION**  
Beautiful, lifetime metal Social Security plate engraved with your name and Social Security number. Eagle and American flag design will make you proud to show it. Sturdy, yet lightweight. Fits easily in wallet or purse. Satisfaction Guaranteed.  
With 2 pocket clearview carrying case and I.D. card. Postpaid \$2.50  
**ASK ABOUT SPECIAL GROUP RATES**  
BRESSLER ENTERPRISES  
5331 10th Ave. S.E., Salem, Ore. 97302

# Sun Shield

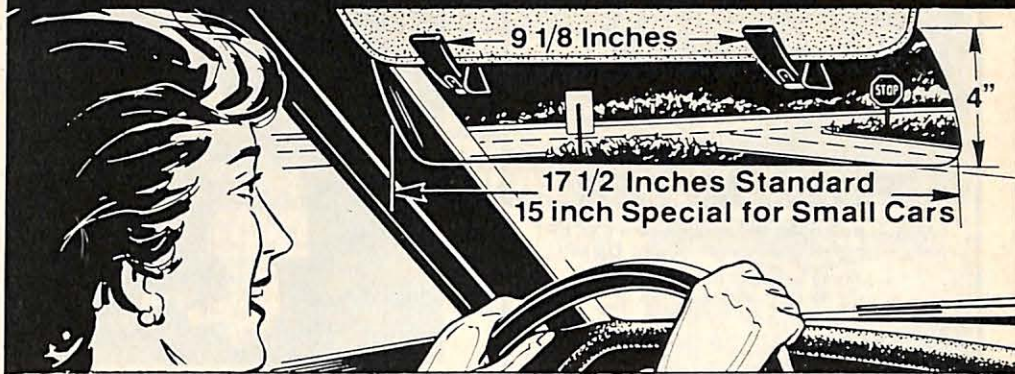

## DOUBLES your driving COMFORT

- Reduces ALL GLARE and HEAT, front or side, Day or Night
- Accepted by leading safety authorities • Positive screw clamps hold securely
- Universally adjustable for look-through or shade-and-look-under.
- SATISFACTION GUARANTEED (Return within five days for full refund)

THE IDEAL GIFT • MOST ENJOYED • MOST APPRECIATED

Sun Shields, Inc. • Box 351 • Plymouth, MI 48170

Check or money order enclosed; Michigan residents ONLY add 4% tax.

- \$5.00 for one Sun Shield, shipped postpaid promptly.
- \$9.00 for 2 Sun Shields - Make your passenger comfortable, too!
- \$42.00 Doz. (minimum, one order) for group buyers - fleet owners.

Specify 15 in. LENGTH (not car model) for sub compact & small foreign cars.

Name \_\_\_\_\_ Street \_\_\_\_\_  
City \_\_\_\_\_ State \_\_\_\_\_ Zip \_\_\_\_\_

## YOU DON'T NEED CASTRO'S PERMISSION TO ENJOY THE UNIQUE HAVANA FLAVOR



If you remember savoring and lingering over a fantastically mild and flavorful Cuban leaf cigar in the days before the Cuban embargo, you will be interested in this offer — and the story behind it!

When the Cuban embargo hit, we and other small manufacturers of fine custom-made cigars faced ruin. Our very existence depended on maintaining the same incomparable quality we had made our reputation on.

The solution was pure cloak-and-dagger. One dark night a few years ago a group of daring Cuban expatriates put to sea carrying a precious cargo of Cuban tobacco seeds. After running a gauntlet of Cuban gunboats they finally reached their destination — Honduras. Here under almost identical conditions of climate and soil, this prime tobacco flourishes to this day, far from its native land. This is the

tobacco we use to make our superbly mild and flavorful cigars — cigars an expert can't tell from Havana.

### MY OFFER TO CIGAR LOVERS

I will send you postpaid a variety of 60 Factory Fresh Cigars. Smoke one or a half dozen with our compliments. If these cigars aren't all you expect and a great deal more, return the remainder by Parcel Post and I'll refund your money. No questions asked. Your delivered cost is only \$9.90 for 60 Factory Fresh Cuban Seed Leaf Cigars.

A-306 To order: Fill in & mail coupon to:  
**THOMPSON CIGAR CO.**  
200 N. Edison Ave., Dept. A-306, Box 1839, Tampa Fl. 33601  
O.K. TOM! Ship me the Victory Sampler under your money-back guarantee for only \$9.90.

- Check for \$9.90 enclosed. (Fla. residents add 4% sales tax.)
- Charge \$9.90 to my
  - VISA
  - Master Charge
  - American Express
  - Diners Club



Credit Card No. (Print All Digits) \_\_\_\_\_  
Master Charge Also Enter EXP. DATE  
4 Digits Below Your Acct. No. \_\_\_\_\_  
name \_\_\_\_\_  
street \_\_\_\_\_  
city \_\_\_\_\_ state \_\_\_\_\_ zip \_\_\_\_\_

CREDIT CARD HOLDERS CALL TOLL-FREE: 800-237-2559



## BEAT THE HIGH COST OF GAS

UP TO  
**20%**  
GAS SAVINGS\*

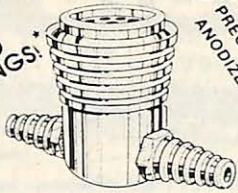

PRECISION ENGINEERED  
ANODIZED ALUMINUM

## FUEL MIZER

Fits ALL American and foreign cars EXCEPT VW's, Fuel Injection Engines and Diesels!

- MORE HORSEPOWER.
- INCREASE PERFORMANCE!
- SAVES GAS!
- BETTER AIR TO GAS RATIO!
- INSTALLS EASILY — NO TOOLS REQUIRED!

There are many energy saving devices on the market today, but FUEL MIZER REALLY WORKS! There are no plastics to over-react to engine heat! Air injection increases performance! Gas prices will continue to rise so take advantage NOW to SAVE in the future. \*According to letters on file.

DISTRIBUTED BY:

F.M. Enterprises  
Box A-165  
1685 Tustin Ave.  
Costa Mesa, CA 92627

ONLY

**19.95**

Calif. Res.  
Add 6%  
Sales Tax

POSTAGE & HANDLING

30 DAY MONEY BACK GUARANTEE



Cheney.  
Because  
Carol loves  
this house.

Carol's illness prevented her from climbing these stairs like she used to. She could move to a one-story house, but she loves this house. A Cheney Weclator™ solved Carol's problem by letting her ride from floor to floor quickly and comfortably. As the first stairway elevator to be UL-listed, it's virtually maintenance-free and can be installed in just a matter of hours. For a colorful brochure on Cheney Weclators, or Wheelchair Lifts and Wheelchair Van Lifts, contact your local Cheney Representative or write: The Cheney Company, Dept. EM, 3015 S. 163rd Street, New Berlin, WI 53151. (414) 782-1100.

Helping people help themselves.  
**CHENEY Weclators.**

## Elks Family Shopper

### consumer/news

Each year, 6,000 Americans die in home fires.

In a new booklet titled *People and Fire*, the Department of Housing and Urban Development gives you the latest fresh information to use to help keep your family out of danger. There are tips on getting out of burning houses fast, and advice for high-rise dwellers. It also gives the homeowner advice on the safest interior finishing materials. For the latest in fire protection information for your home and family, send \$1.30 to the Consumer Information Center, Dept. 93G, Pueblo, Colorado 81009.

If you think that the rising cost of credit means it's useless to comparison shop anymore, it's time to revise your thinking. You still can  
*(Continued on page 38)*

## FACTORY SPECIAL — \$299.95

WE BUILD IT!  
Buy direct from our factory and save!

Dozer blade and grass catcher available.

Free Delivery. Big 26" cut. Order now or send for free picture brochure while they last.



★ Big powerful 8 H.P. Briggs & Stratton engine. Compare at \$529.95

not a 'MUSTANG'. We have a bigger cut plus other features.

RIDING MOWER THE CONTINENTAL MARK VIII

CONTINENTAL MFG. DEPT. E  
3205 E. Abrams St. Arlington, Tx 76010 817-640-1198

## CUSTODIANS - HOUSEWIVES



Homes - Schools - Churches - Bars - Commercial Bldgs. Hospitals - Restaurants. If you work in or own these types of businesses you need this plastic disposal probe to remove debris (cigarette butts, bones, broken glass, gum, toothbrush, wash clothes, paper towels, toothpicks, wrappers, etc.) from sinks, toilets, cat boxes, garbage disposals & urinals. U.S. Patent # 4012068. Approx. length 15½ inches. Send \$3.99 + \$1.50 shipping fees to:

PODAC ENTERPRISES, LTD.,  
11896 Lavinia Lane, Northglenn, CO 80233

• NON-POLLUTING • NO DEAFENING NOISE •

Quiet Power



## 12 VOLT Chain Saw

- Runs off battery in your car or truck
- Can cut a pickup load of wood. still leaves plenty of juice to start vehicle.
- Famous super-tough Oregon bar & chain.
- Approved for Highway Department use.
- Sold and used around the world.

For Free Information, write: Tensen Dept. 196, 1218 N.W. Glisan, Portland, OR 97209

MAINTENANCE-FREE • INSTANT START • TOUGH, BUT NOT TOO HEAVY FOR LADIES • NO FIRE DANGER • NEEDS NO GASOLINE

Your Dollar Still Has Clout At RVP



**\$1.00 BRINGS YOU 100 Vitamin E 400 I.U.**

Mail **\$1.00** Today To:

(LIMIT ONE BOTTLE PER HOUSEHOLD WITH THIS AD)



**Vitamin Products**

16 NASSAU AVENUE ROCKVILLE CENTRE, N.Y. 11570

8ELK-21

NAME \_\_\_\_\_

ADDRESS \_\_\_\_\_

APT. \_\_\_\_\_

CITY \_\_\_\_\_

STATE \_\_\_\_\_

ZIP \_\_\_\_\_



## FLY-GONE

**KILLS FLIES**

outside before they enter the house. The safe, energy-saving answer to control of filthy, pesty, disease-carrying flies. Uses no electricity—no chemicals—no poisons.

Add 50¢ for postage and handling. Calif. residents add 6% sales tax.

**\$3.99**

FLY-GONE DISTRIBUTING CO.  
P.O. Box 4308 / Panorama City, CA. 91412  
A Division of Aristo-Craft Metal Products Co

PLAY ANY TUNE



With A TRU-TONE HARP

Only \$5.95 + 75¢ for Shipping

\* NEW PATENTED DESIGN

\* FINEST JEW'S HARP MADE

\* CLEAR MUSICAL SOUND

\* ILLUSTRATED INSTRUCTIONS

TRU-TONE HARP CORP. Box E  
4805 S.E. 26th • Portland, OR • 97202



See Advertisement on Back Cover

Haband's new man-made in U.S.A.

**EXECUTIVE SHOES**  
**HABAND COMPANY**  
 Direct Service Dept.  
 265 N. 9th St., Paterson, N.J. 07530

**2** Pairs for **24<sup>95</sup>**  
 Only

3 for 37.35 4 for 48.90 5 for 61.00

OK, Gentlemen: Please send me \_\_\_\_\_ pairs of your famous shoes as specified hereon, and for which I enclose my remittance of \$ \_\_\_\_\_ plus \$1.15 for postage and handling. 72E-430

Color & Style	Qty.	Size	Width
Brn. & White Loafer			
Black Wing-Tip			
White Reptile Grain			
Brown Tassel Loafer			
Lt. Brn. Slip-on Loafer			
Black Loafer			

Print Name \_\_\_\_\_  
 Street \_\_\_\_\_ Apt. # \_\_\_\_\_  
 City - State \_\_\_\_\_ Zip \_\_\_\_\_

See Advertisement Inside Front Cover

**SATISFACTION GUARANTEED OR MONEY BACK**  
**OLD VILLAGE SHOP**

Dept. VM-3842, 340 Poplar St., Hanover, Pa. 17331

Sure, I'll try the world's most comfortable shoes. Please send me:

**MEN'S SHOE**  
 ...prs. Tan Leather (M242578B) Size \_\_\_\_\_ Width \_\_\_\_\_  
 ...prs. Black Leather (M236892B) Size \_\_\_\_\_ Width \_\_\_\_\_  
 ...prs. Brown Sueded (M242568B) Size \_\_\_\_\_ Width \_\_\_\_\_  
 ...prs. Sand Sueded Leather (M233361B) Size \_\_\_\_\_ Width \_\_\_\_\_

**WOMEN'S SHOE**  
 ...prs. Tan Leather (M203562B) Size \_\_\_\_\_ Width \_\_\_\_\_  
 ...prs. Black Leather (M203687B) Size \_\_\_\_\_ Width \_\_\_\_\_  
 ...prs. White Leather (M223693B) Size \_\_\_\_\_ Width \_\_\_\_\_  
 ...prs. Brown Sueded (M223784B) Size \_\_\_\_\_ Width \_\_\_\_\_  
 for just \$14.99 pr., plus \$2.25 per pr. post. & hdlg.  
**SAVE MORE!** Order Two pair for just \$28.99 plus \$4.00 postage and handling.

**CHARGE IT**  
 AMERICAN EXPRESS  
 BANKAMERICARD - VISA  
 CARTE BLANCHE  
 DINERS' CLUB  
 MASTER CHARGE Interbank No. \_\_\_\_\_

Acc't No. \_\_\_\_\_ Date Expires \_\_\_\_\_  
 Enclosed is \_\_\_\_\_

NAME \_\_\_\_\_ (please print)

ADDRESS \_\_\_\_\_

CITY \_\_\_\_\_

STATE \_\_\_\_\_ ZIP \_\_\_\_\_

# Help!

The Elks Magazine postage fees have skyrocketed!

Help us cut costs by reporting any address change to your lodge secretary and The Elks Magazine Circulation Department.

Be sure to include lodge and membership number or an address label from the magazine. **Notice should be sent 6 to 8 weeks before your move.**

ATTACH ADDRESS LABEL HERE

New Address:

Name \_\_\_\_\_

Address \_\_\_\_\_

City \_\_\_\_\_

State \_\_\_\_\_ Zip \_\_\_\_\_

Lodge No. \_\_\_\_\_

Member No. \_\_\_\_\_

Mail to: Circulation Manager  
 The Elks Magazine  
 425 W. Diversey Pwy.  
 Chicago, IL 60614

7-9

**Drive More Safely—Arrive More Relaxed!**

## DELUXE WIDE ANGLE REAR VIEW MIRROR

**only \$5<sup>98</sup>**



**Shows you 6 lanes at a glance**

How many times have you narrowly escaped disaster from a car in the next lane sneaking up on your "blind spot"? With freeway traffic getting heavier and heavier, this deluxe wide angle oversized mirror could be the best investment in safety you ever made! 13½" long by 3¼" wide with 43 sq. in. of viewing area, it reduces your blind spots by giving you a clear view of 6 lanes behind and on both sides too!

It eliminates that stiff neck you get from constantly twisting to watch traffic in lanes next to you — eliminates a lot of the strain and tension of driving with unseen traffic to the right and left of you. And lets you drive more safely, with more confidence, arrive less tired and more relaxed after a long trip.

**Order risk-free today**

Why let a single unnecessary day go by without equipping every car you own with this great safety device . . . especially when it is such a snap to install, and costs you less than half as much as smaller mirrors we've seen advertised in 1978! If not delighted, return within 14 days for full refund (except postage and handling). Rush your order now — mail coupon today!

© 1979 Panacolor, Inc., Caroline Rd., Phila., PA 19176

**MAIL NO-RISK COUPON TODAY**

**AMERICAN VALUE**, Dept. WVM-68, Caroline Road, Philadelphia, PA 19176

Please rush me \_\_\_\_\_ (WVM) DeLuxe Wide Angle Rear View Mirror(s) at only \$5.98 plus 95¢ postage & handling per mirror.

**SAVE:** Equip two cars and save \$2.38 — two mirrors only \$9.98 plus \$1.50 postage & handling.

If after receiving my order I'm not delighted, I may return it within 14 days for refund (except postage & handling).

Total amount enclosed \$ \_\_\_\_\_ PA residents add 6% sales tax. Check or money order, no COD's please.

Canadian Customers please send orders to: Mail Store Ltd., Dept. WVM, 170 Brockport Drive, Rexdale, Ontario M9W 5C8 3321-007 (Ontario & Quebec residents add sales tax)

Div. of Panacolor, Inc.

---

**CHARGE IT:** (check one) Exp. Date \_\_\_\_\_

Visa  American Express

Master Charge Bank # \_\_\_\_\_

Credit Card # \_\_\_\_\_

Name \_\_\_\_\_

Address \_\_\_\_\_ Apt. # \_\_\_\_\_

City \_\_\_\_\_ State \_\_\_\_\_ Zip \_\_\_\_\_

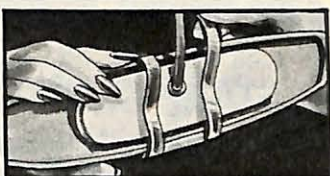

• Installs in seconds right over your present mirror

• Oversized Panoramic view - 80% more vision area than mirrors advertised in 1978 at \$12.95!

• Day-night control switch cuts high-beam glare



## ADJUSTABLE CAPS

WITH EMBLEMS USE FOR:  
 Safety awards, incentive for production goals, product promotion, advertisement, conventions, company picnics, trade shows, attendance awards.  
 Choose the cap that fits your need. Send us a copy of your logo or a rough pencil sketch and we'll do the rest. Your emblem expertly made and sewn on the best caps available.

Please furnish the following information:

- Style No. \_\_\_\_\_ How Many \_\_\_\_\_
- Copy For Emblem \_\_\_\_\_
- Color \_\_\_\_\_ Royal Blue, Navy Blue, Red, Black, Orange, White, Gold, Kelly Green

Price includes one 1-color emblem sewn on front of cap. (Minimum Order --- 72)

72	144	288	432	864	1728
\$3.45 ea.	\$2.98 ea.	\$2.85 ea.	\$2.75 ea.	\$2.65 ea.	\$2.55 ea.



Highway 460-92 Box 275 TOLL FREE  
 Grundy, VA 24614 800/336-0551  
 Alaska, Hawaii and Virginia  
 Call Collect 703/935-4545



## THE GARDEN WAY CIDER PRESS

Making cider can be as much fun (and as easy!) as drinking it! With Garden Way's complete system, fresh cider is just minutes from the tree. Grind apples (and many other fruits) in the top-mounted grinder — then press the pulp into delicious cider and juices. Full bushel capacity — stands over 4 ft. tall. Constructed from spruce and Vermont maple hardwood to last a lifetime. Available also in two money-saving kits. Send for FREE information TODAY!

### GARDEN WAY RESEARCH

Charlotte, Vermont 05445

**Garden Way Research**  
 Dept. 90127P  
 Charlotte, VT 05445

Please send FREE information about the Garden Way Cider Press and Cider Press Kits.

Name \_\_\_\_\_

Address \_\_\_\_\_

City \_\_\_\_\_

State \_\_\_\_\_ Zip \_\_\_\_\_



**"SAVE YOUR HEART"**



with a **STAIR-GLIDE®** Stairway Lift

**RENTAL-PURCHASE Program Available**

America's largest selling stairway lift. Ideal for people who cannot or should not climb stairs. Easily installed in less than 2 hours without damaging stairway. Runs off household current. Choose from Deluxe or Economy models.

**AMERICAN STAIR-GLIDE® CORP.**  
4001 East 138th, Dept. E-79  
Grandview, Missouri 64030

**U.S. COINS BY THE POUND & GOLD**



Rather than sort overflowing vaults, these are sold by the pound! **GOLD PIECE** of the world added! All coins 30-150 years old. May include Indian, Lincoln cents; silver dollars; 2¢; 3¢ pcs. etc. 1 lb.—\$16.50; 2 lbs.—\$30; 5 lbs.—\$72; 10 lbs. (plus 2 gold pcs)—\$130.



**LAST U. S. SILVER COIN SETS**  
Never again will silver be used in coin mintage! Most has already been melted so these UNCIRCULATED coin sets increase in value! 1964-\$8.50; 1963-\$9; 1962-\$9.50; 1961-\$10; 1960-\$10.50. All 5 sets \$45 (mounted in lifetime holders). Special 1955 thru 1959-\$98. All major credit cards accepted. (Add exp. date.) Add \$2 for ins. & hndlg. Centre Coin Co., Box 1, Dept. K7, Sherman Oaks, Calif. 91413.

**Elks Family Shopper**  
consumer/news

save when borrowing money—just by shopping around.

A new, free 46-page booklet from the Federal Reserve Board called the *Consumer Credit Handbook*, tells you what to look for. For your copy, just send a postcard to the Consumer Information Center, Dept. 659G, Pueblo, Colorado 81009.

There are two figures you'll need to know when comparing credit costs: the finance charge and the annual percentage rate (APR). The finance charge gives you the total cost you must pay for borrowing the money you need. That includes the interest, some service charges, insurance, and appraisals, if required. The annual percentage rate or APR is your finance charge expressed as a yearly percentage of the money you borrowed. ■

**Unique COIN COUNTER & PACKAGER**



**\$3.00**  
2 for \$5.00  
3 for \$6.00

plus .50 (p-H)  
Pa. residents add 6% sales tax

Enables you to accurately count pennies, nickels, dimes and quarters in standard amounts and easily place them into standard tubular coin wrappers. Plastic and pocket size. Dealer inquiries invited.

**CHESSMAN CORP., Dept. E-9**  
307 Susquehanna Ave., Wyoming, Pa. 18644

**SAVE UP TO \$215.80**

on a famous **TROY-BILT Tiller!**



**Just ONE HAND!**

"Off Season Savings" now in effect! Right now is the best time ever to learn about the amazing TROY-BILT Roto Tiller-Power Composter... the "breakthrough" machine that's allowing anyone—of any age—with any soil—to easily have a fabulously fertile, productive garden! For free complete details, prices, write today to: TROY-BILT Tillers, Dept. 90557, 102nd St. & 9th Ave., Troy, NY 12180.

**In just One Season Make a TON OF COMPOST**



Turn garden and kitchen wastes into rich fertile compost to improve poor soil and feed your plants. Grow beautiful harvests of vegetables and more beautiful flowers. Scientifically designed bins produce valuable compost in weeks. No turning the heap. Make a ton in one season. Send for free catalog.

**Rotocrop (USA) Inc.**  
178 Aero Park  
Doylestown, Pa. 18901

**SIDLES AUTO SUN SHADES**

"Take the sizzle out of the sun!"

DOES NOT OBSTRUCT VIEW



**RIDE UP TO 15° COOLER with SIDLES SHADES**  
Custom made from durable aluminum to block out the sun's rays. Easily installed and instantly removable. Increases air conditioner efficiency and saves passengers and contents from the ravages of a blazing sun. For free information send year, make, series, model (sedan, station wagon, pickup, bus, etc.), and style (2 or 4 door), with your name and address to: SIDLES MFG. CO., INC., Box 3537E, Temple, TX 76501. For questions and/or same day shipment on Master Charge/VISA/UPS COD phone orders, call TOLL FREE (800) 433-3101. In Texas call (817) 778-1636.

**NOW! MAKE YOUR OWN BADGES BIG PROFITS, FUN, TOO!**



Fill constant demand for colorful, plastic-protected, metal pin-back badges and buttons with the improved **BADGE-A-MINIT**. Buttons, key-chains, purse mirrors sell fast at shops, malls, fairs. Take orders from clubs, schools. Parts cost just pennies each. Fun and profit for you, creating badges. Write for free sample button and details or send \$24.95 (plus \$1.75 shipping and 5% tax-ill. residents) for complete **BADGE-A-MINIT** containing die press, color-coded dies, one dozen badge parts, illustrated instructions.

**GET FREE SAMPLE BUTTON AND NEW COLOR CATALOG**

**BADGE-A-MINIT, Ltd.** Box 618, Dept. E79, LaSalle, IL 61301

**ENJOY MORE GOLF**



Whether you're just starting golf or are tired of toting a bag full of clubs, **golf can be more fun and less tiring** when you use the Adjustable®. A great club for practice—wherever you are, when the course is too wet for carts, for par 3 courses or traveling. The New Adjustable All-In-One golf club adjusts to driver, 3, 5, 7, 9 iron, sandwedge and putter. Only one club to carry and get used to, **master and enjoy**. Many golfers use it all the time and find their scores are just as good as with a full set. Money back guarantee. \$47.95; 2 for \$89.95. For MasterCard and Visa, send number and expiry date or order toll free-800-621-5809. (Illinois residents 800-972-5858) **Please specify** right or left handed & height for proper club length.

**INTERNATIONAL GOLF PRODUCTS**  
1865 J Campeau Street • South Bend, IN 46617

**SAVE HUNDREDS of DOLLARS**

**WITH BURKE SEAT-LIFT CHAIRS**



**Free Week Home Trial**

**Ask about Medicare coverage**

Now's the time to save hundreds of dollars with a comfortable Burke recliner. Burke seat-lift chairs let you stand and sit when you want, with less strain. Power recline to any position, automatically elevating your feet and legs. Write for information and compare.

**BURKE** P.O. Box 1064, Dept. E-779  
c. Mission, Kansas 66202  
or call TOLL FREE 1-800-255-4147



**NEW SPACE-AGE PAINT STRIPPER *WIPES LIKE A SPONGE!***

**STRIPS AWAY OLD PAINT, VARNISH,  
WITH JUST ONE LIGHT WHISK!**

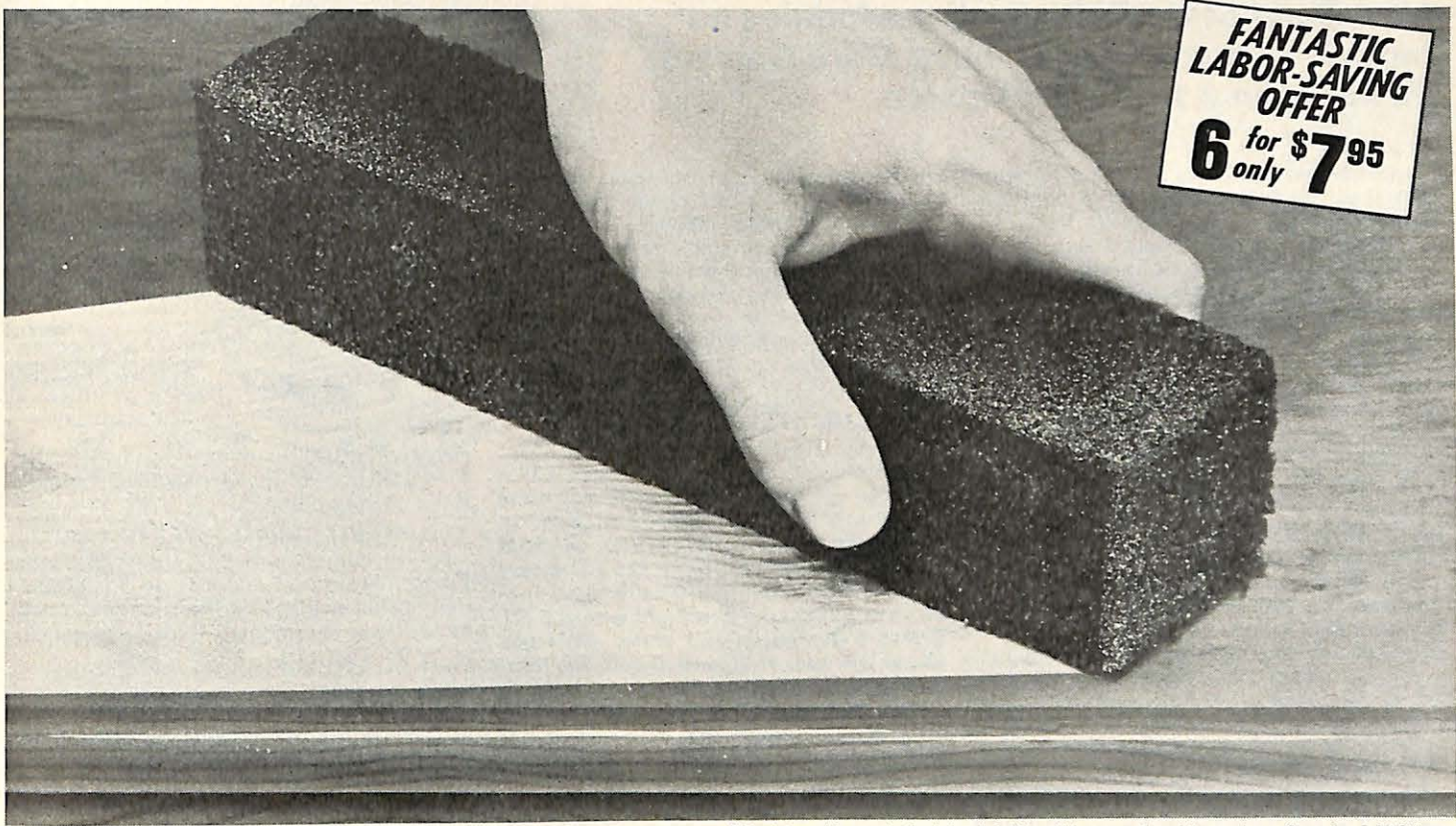

This photographic accentuation helps depict the whisk-away action of the wonderful Space-Age Paint Stripper.

**Now Strip Away Anything *FAST!***

- No Sanding • No Blasting • No Scraping • No Burning
- No Dangerous Power Tools • No Harmful Chemicals

**MEET THE STRIPPER!** It's space age science's super efficient paint and varnish remover that *erases away, strips away, whisks away caked paint, tough varnish and years of grime with light easy strokes.* That's not a promise—*THAT'S A GUARANTEE!* You'll be absolutely amazed at the results. THE STRIPPER moves across facades and veneers easily as it turns those caked, scarred, crusty surfaces into smooth, bare finishes F-A-S-T!

**THE STRIPPER works just as well on all kinds of tough problems** without sanding—without scraping—without burning or blasting—without harsh chemicals or power tools. So powerful it **STOPS RUST DEAD IN ITS TRACKS** as you erase those ugly stubborn patches down quickly to clean, bare metal. **No hard rubbing!** Just light erasing motions and you strip paint, varnish, rust, etc., from furniture, walls, doors, cabinets, boats, grills, cars, pipes, etc. Perfect for tackling thousands of tough, nasty jobs. It ends the need for sandpaper and caustic solvents.

The result of space age technology THE STRIPPER has thousands upon thousands of microscopic points that work *efficiently and scientifically to strip away, whisk away, erase away old paint, rust and varnish with a simple erasing motion.* Satisfaction guaranteed. Order today.

**RESULTS GUARANTEED—TRY AT OUR RISK**

The Stripper that looks and weighs like a sponge comes to you with this amazing "Use it and abuse it" no nonsense guarantee: Tackle your toughest jobs. Be amazed at how much labor the Stripper saves you. If you are not pleased and delighted with its incredible performance return within 14 days for a full refund of your purchase price (less postage and handling, of course). Order several sets today.

**DOES ALL THIS:**

- ✓ "Whisks-off" years and years of old paint.
- ✓ Strips away rust down to bare metal fast!
- ✓ Restores furniture to smooth paint-free finish.
- ✓ "Erases" years of grime and varnish as if by magic.
- ✓ Perfect for hundreds of jobs on walls, doors, cabinets, cars, grills, furniture, etc.

REMOVES RUST      CONTOUR CONTROL      WHISK AWAY ACTION

© 1979, Encore House, Inc., Roberts Lane, Glen Head, NY 11545

**MAIL THIS NO-RISK COUPON TODAY**

SPACE-AGE STRIPPER, Dept. SAS-106  
Roberts Lane, Glen Head, NY 11545

Please RUSH me the Incredible SPACE-AGE PAINT STRIPPER(s) with the understanding that if I am not completely thrilled and delighted with the way it completes my toughest jobs I may return for a full refund of my purchase price within 14 days (less postage and handling, of course). Check offer desired:

(#001) 1 Carton of Six Strippers for only \$7.95 plus 50¢ postage and handling.

(#002) **SAVE \$3.20!**—2 Cartons for only \$12.95 plus 75¢ postage and handling.

(#003) **SAVE \$7.40!**—3 Cartons only \$16.95 plus \$1 postage and handling.

Amount enclosed \$\_\_\_\_\_ (NY residents please add sales tax). No C.O.D.'s please.

**CHARGE IT!**  VISA (BankAmericard) Exp. \_\_\_\_\_

Master Charge Date: \_\_\_\_\_

Credit Card # \_\_\_\_\_

Name \_\_\_\_\_

Address \_\_\_\_\_

City \_\_\_\_\_ State \_\_\_\_\_ Zip \_\_\_\_\_



# Portable refrigeration breakthrough makes ice chests obsolete!

**New Solid State Refrigeration Modules no bigger than your watch, have More Cooling Power than a 10lb. Block of Ice.**

Your ice chest is bulky, awkward to carry, messy and inefficient at keeping its contents cold. You have to buy ice every day, if you can find it, throw away the spoiled soggy food and drain off the water repeatedly.

Conventional portable refrigerators are either too heavy, too noisy, drain your battery too quickly or need to be kept level.

These problems and inconveniences have finally been resolved in one totally new product - the Koolatron 12 volt portable electronic refrigerator. We believe the Koolatron portable represents such a dramatic advance in refrigeration for recreational use that all existing methods are now outmoded.

## USES AEROSPACE REFRIGERATION MODULES

The Koolatron portable cools your food electronically with solid state thermoelectric refrigeration modules. These same powerful modules are used by military and aerospace scientists to cool critical components in rockets and satellites. They use thermoelectric cooling because of its absolute reliability, insensitivity to motion or level, small size & weight and minimal battery drain.

## WHY IS THE KOOLATRON PORTABLE SO MUCH BETTER THAN AN ICE CHEST?

An ice chest maintains an air temperature of 50-60 deg. F. Meat and milk spoil rapidly at temperatures above 50 deg. F. which is why the top of your meat will go bad even when it is sitting on ice. Koolatron portables maintain normal home refrigeration temperatures of 40-45 deg. F. even in 95 deg. F. weather.

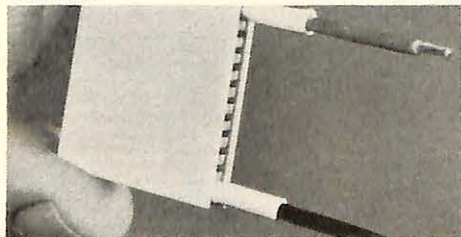

Two of these miniaturized thermoelectric modules replace all the bulky complex piping coils, compressors and motors in conventional portable refrigerators. The modules pump heat from your food into efficient heat sinks where it is dissipated by a quiet fan. They operate on a principle called the "Peltier Effect" - passing electricity through the junction of dissimilar metals causes heat to flow away from the junction.

## BOATING, FISHING, CAMPING, HUNTING

Fits into virtually any boat, van or camper. Carry it on the back seat during car trips. Ideal for fishing and hunting - bring your catch back home fresh (a few loads of fish filets could pay for your portable). Use it for grocery shopping, medicines, carrying film, salesman's samples. Take it to the drive-in movies, auto races and other sporting events. With an inexpensive battery charger

you can use your Koolatron as a bar fridge all winter and a patio fridge in the summer. Run it in your motel room at night and enjoy a midnight snack whenever you feel like it. We have customers using our portables on construction sites, in workboats, laboratories and even in locker rooms for a "cold one" after the game.

## THE ULTIMATE PORTABLE REFRIGERATOR

It weighs less than most coolers with a block of ice but holds over 40 pop cans or 40 lbs. of food in its large 36 qt. capacity. Plug it in a lighter socket in your car, boat or van or operate it from a 12 volt battery charger plugged into 110 volts. Cold contents will stay cold overnight with unit off. Draws a maximum of 4 amps., averages about 2 amps. at 70 deg. F. with the thermostat on. Keeps your food cold and dry. Exterior dimensions are 21" L x 16" W x 16" H. Interior dimensions are 16" L x 11-1/2" W x 12" H.

## BUILT-IN QUALITY AND DURABILITY

The rugged "ABS" case is filled with the best insulation available - rigid urethane foam. It has a "150 lb. test" handle and non-rusting polypropylene hinge and latches, with stainless steel fasteners. The exterior is harvest gold with a white interior and has 4 non-slip rubber feet. Your portable comes with a 9 ft. detachable cord which plugs into your cigarette lighter. It also has terminals for attaching wires directly from a battery or fuse panel. The same terminals are used for your battery charger clips when operating from a charger. A reverse polarity warning light & buzzer are included. The Koolatron was designed so that the fan motor can be replaced by you with only a screwdriver. No other service should ever be required except for physical damage which can be repaired at our depots in Batavia, N.Y., or Barrie, Ontario.

## GUARANTEE. 21-DAY MONEY-BACK TRIAL PERIOD

Your Koolatron comes with a written 1 year guarantee plus complete instructions and helpful information about batteries and chargers. If for any reason you are not totally satisfied, return it for a prompt refund in full.

## BUY NOW AT OUR NEW LOW PRICE

Good news. Our increased sales have overcome mounting material costs. So for now we can pass on a



The Koolatron portable keeps 40 lbs. of food at household refrigeration temperature but weighs only 15 lbs. Only 21" x 16" x 16" ext. Model F1A shown.

saving of \$10.00 per unit. Formerly \$169.00. Now \$159.00 + \$7.00 handling and shipping (\$179.00 in Canada).

## ADJUSTABLE THERMOSTAT OPTION

For an additional \$10.00 you can order the Koolatron portable with an adjustable thermostat in place of the standard fixed temperature thermostat - order Model F1A.

## PAYS FOR ITSELF

If you are regularly using ice, your Koolatron portable will pay for itself with the money you save on ice, spoiled food, restaurant bills and the gasoline used looking for ice.

**Don't Waste Another Dollar on Ice!**

Phone your order in collect to

**705-737-0842**

Koolatron Industries Limited,  
56 Harvester Ave., Batavia, New York 14020  
230 Bayview Drive, Barrie, Ontario, Canada  
Or use this handy order coupon.

**Koolatron**  
INDUSTRIES  
LIMITED

Dept. 607

56 Harvester Ave., Batavia, New York 14020  
Canada: 230 Bayview Drive, Barrie,  
Ontario L4N 4Y8

Send me \_\_\_ Koolatron F1 @ \$159.00 (\$179.00 in Canada) + \$7.00 each for handling and delivery in USA or Canada. (N.Y., Ont. and Que. residents add sales tax.)

\_\_\_ I want model F1A and have added \$10.00. I understand that I may return it undamaged within 21 days and get a full refund if I am not satisfied. I enclose my  check  money order for \$\_\_\_\_ or, please charge my  Visa  Mastercharge  American Express.

Acct. No. \_\_\_\_\_

Expiry Date \_\_\_\_\_  Send brochure only

Signature \_\_\_\_\_  
(necessary to ship merchandise)

Name \_\_\_\_\_

Address \_\_\_\_\_

City \_\_\_\_\_

State \_\_\_\_\_

Zip \_\_\_\_\_





"I love coffee, but caffeine made me nervous. Then I switched to SANKA® Brand. Now, I get a terrific tasting cup of coffee, and feel terrific, too!"

"Well, Fred, that's because SANKA® Brand is 97% caffeine-free. But it's 100% real coffee, and tastes it!"



# SANKA®. THE 100% REAL COFFEE

BRAND DECAFFEINATED COFFEE

## THAT LETS YOU BE YOUR BEST.

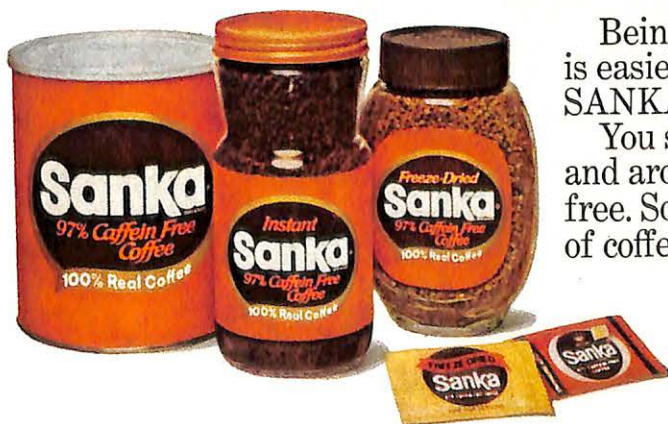

Being your best and getting a great tasting cup of coffee is easier than you think. All you have to do is switch to SANKA® Brand Decaffeinated Coffee.

You see, SANKA® Brand has the full-bodied taste and aroma of 100% real coffee. But it's 97% caffeine-free. So you get all the enjoyment of a good cup of coffee, without getting caffeine.

Join the millions of caffeine-concerned Americans who have turned to SANKA® Brand: It's the 100% real coffee that lets you be your best.





100% man-made  
in U.S.A.

# BIG SAVINGS ON SHOES!

Even these Luxurious New Styles!

**2** Pairs for Only **24<sup>95</sup>**

Why pay higher and higher prices for shoes? Here is one place you can

## Save Without Sacrifice!

For convenient  
**NO-RISK AT-HOME INSPECTION**  
of ANY SHOES  
ON THIS PAGE.

Just tell us  
your choice  
on  
**EASY ORDER FORM**  
**BELOW** and

See Them On Approval!

2 pairs  
for 24.95

### CAN YOU WEAR THESE SHOES?

Of course you can! Even men who used to spend \$50 and \$100 per pair for shoes, now write to Haband, in Paterson, New Jersey, whenever they need shoes.

**Our Specialty is Comfort!** All our shoes are made on a unique set of beautiful hand-carved lasts, and we fit to your exact size and width, **NO FOOLING AROUND!** You get all the most tasteful, interesting new styles in beautifully grained and richly antiqued uppers that keep their shape, are absolutely weatherproof, and never need a shine. You get life-of-the-shoe one-piece heel and sole, with flexible, built-in support shank in the arch, deluxe new inner sole, heel counters and quarter linings, you name it — The Works! And remember — this is no "Save 10¢" bargain offer. You can easily save \$10 to \$30 per pair from your regular shoe prices. Don't pass such savings by!

Brown and White  
Loafer

Black  
Wing Tip

White  
Reptile Grain

Brown  
Tassel Loafer

Lt. Brown  
Slip-On  
Loafer

### HOW TO GET ACQUAINTED

Haband is a conscientious family business, operating by U.S. Mail since 1925. We serve over 2-million active customers direct to the home, and sooner or later you too will discover just how great these savings can be!

So why wait? Don't overspend even one penny more on shoes! We will be proud to show you this remarkable new way of doing business: Just tell us your size and choice of styles on coupon at right. Two pairs for only \$24.95! We promise fast reliable service, and you will be amazed at the incredible value. **Do it today!**

# HABAND

265 North 9th Street  
Paterson, New Jersey 07530

Haband's new man-made in U.S.A.

## EXECUTIVE SHOES

2 Pairs for Only **24<sup>95</sup>**

3 for 37.35  
4 for 48.90  
5 for 61.00

HABAND COMPANY Direct Service Dept.  
265 N. 9th St., Paterson, N.J. 07530

OK, Gentlemen: Please send me ..... pairs of your famous shoes as specified hereon, and for which I enclose my remittance of \$....., plus \$1.15 for postage & handling.

**GUARANTEE:** I understand that if upon receipt of the shoes I am not completely delighted with my purchase, I may return them to Haband within 30 days for full refund of every penny I paid you.

72E-430

IS YOUR SIZE ON THIS CHART?

	5½	6	6½	7	7½	8	8½	9	9½	10	10½	11	12	13
A														
B														
C														
D														
E														
EEE														

Name ..... Please Print ..... Apt. ....  
Street ..... # .....  
City & State ..... ZIP CODE .....

Color & Style	Qty.	Size	Width
Brown and White LOAFER			
Black WING-TIP			
White REPTILE GRAIN			
Brown TASSEL LOAFER			
Light Brown SLIP-ON LOAFER			
Black LOAFER (not shown)			