

the  
**Elks**  
magazine  
March 1979

THE  
ELKS  
NATIONAL  
MEMORIAL  
BUILDING





# Thrives Where Seed and Sod Fail!

## ZOYSIA GROWS DENSE GREEN PERFECT LAWNS IN MOST ANY SOIL & CLIMATE



### FREE! Bonus Plugs With Every Order!

- Perfected by the U.S. Government
- Released by the U.S. Golf Association
- Won't Winter Kill . . . Survives 30° below zero!
- Won't Heat Kill . . . When other grasses burn, Zoysia stays green!
- Thrives in "problem" spots — Slopes and Bare Areas!
- Resists Insects & Disease!
- Chokes Out Crabgrass, Weeds!
- Needs Less Mowing, Less Watering than ordinary grass!
- Plug it in Without Ripping Out Present Grass!

**LAKELAND'S NEW FRESH-FROM-THE-FIELD SHIPPING POLICY**  
 Now, we've added a brand new **Midwestern Distribution Center** to our **National\*** shipping network. Your **Lakeland Zoysia** arrives even **faster than before!** Quicker delivery guarantees **fresh, healthy plugs** brought right to your yard the most **economical way—ever!**

\*Eastern customers will continue to be supplied from our Eastern Center.

**YOU INVEST IN A SURE THING with Zoysia Plugs!** You're not spending money and time on a lawn only to see the seeds washed away by rain . . . or have the newly-established grass burned by the sun just when you're ready to enjoy it!

**NEEDS LITTLE OR NO CARE!** Best of all, you're not a "lawn slave." Zoysia stays a lush, rich green through droughts . . . chokes out crabgrass, needs less watering, about 2/3 less mowing! In other words, you're liberated—free to go on vacation, play golf . . . Summertime becomes funtime, not lawntime!

**A TRUE PERENNIAL—PRACTICALLY INDESTRUCTIBLE!** Now you can own a thick green hardy lawn, as luxurious as a deep-pile carpet. Merely place the living pre-cut Zoysia Grass Plugs in the ground, and they'll

flourish thicker and wider until they spread over your entire lawn. Yes, there's no need to rip out your existing grass! And once established, the Zoysia "lawn carpet" becomes so tough, so resilient that it withstands cook outs, lawn parties, children's play! Zoysia thrives even on sandy or clay soil. Only following sharp frost will its colors burn out, but it renews itself as ever in the spring! A true care-free perennial for every climate! Plant the plugs 1-ft. apart. All instructions included.

**NO-BEND STEP-ON PLUGGER FOR FAST, EASY DIGGING** . . . Light but rugged 2-way Plugger operates from standing position, saves bending. Cuts away present growth as it digs hole for each plug. Fast, easy, efficient . . . anyone can use it.



**GUARANTEED-TO-GROW  
 ZOYSIA PLUGS SAVE  
 TIME, WORK, MONEY!**

**(Our Plugs Are  
 the Lowest-  
 Priced . . .  
 the Finest  
 Quality Famous  
 Meyer Z-52  
 Zoysia Grass!)**

By Mike Senkiw  
 Agronomist,  
 Lakeland Nurseries

### LAKELAND'S DOUBLE GUARANTEE

- 1) All Zoysia plugs must be received by you in perfect condition or notify us promptly for free replacement, or refund, whichever you prefer.
- 2) All Lakeland Zoysia plugs must thrive, after planting, or we will replace them anytime within three full months.

**LAKELAND NURSERIES SALES, Dept. NL-1253**  
 Hanover, PA 17331

Zoysia also on sale at Lakeland Nursery Barn, U.S. Rte. 30, W. Abbottstown, PA., 20 min. East of Historic Gettysburg.

Please send the guaranteed Zoysia Plugs checked below:

- |   |   |  |
|---|---|--|
| <input type="checkbox"/> FULL SIZE PLUGGER (L000778H) | <input type="checkbox"/> 100 PLUGS (L000927Y) Plus Bonus of 25 FREE PLUGS \$4.95                    | <input type="checkbox"/> 100 PLUGS & PLUGGER (L000950Y) PLUS 25 FREE PLUGS \$8.88 (SAVE \$3.42)      |
| <input type="checkbox"/> 200 PLUGS (L000935Y)         | <input type="checkbox"/> 200 PLUGS & PLUGGER (L000968Y) PLUS 50 FREE PLUGS \$9.88 (SAVE \$4.82)     | <input type="checkbox"/> 200 PLUGS & PLUGGER (L000976Y) PLUS 125 FREE PLUGS \$12.88 (SAVE \$6.77)    |
| <input type="checkbox"/> 500 PLUGS (L000943Y)         | <input type="checkbox"/> 500 PLUGS & PLUGGER (L000976Y) PLUS 125 FREE PLUGS \$19.88 (SAVE \$16.87)  | <input type="checkbox"/> 500 PLUGS & PLUGGER (L003301Y) PLUS 250 FREE PLUGS \$22.88 (SAVE \$18.82)   |
| <input type="checkbox"/> 1000 PLUGS (L003293Y)        | <input type="checkbox"/> 1000 PLUGS & PLUGGER (L007666Y) PLUS 250 FREE PLUGS \$29.88 (SAVE \$43.62) | <input type="checkbox"/> 1000 PLUGS & PLUGGER (L007666Y) PLUS 375 FREE PLUGS \$32.88 (SAVE \$45.57)  |
| <input type="checkbox"/> 1500 PLUGS (L007633Y)        | <input type="checkbox"/> 1500 PLUGS & PLUGGER (L006296Y) PLUS 375 FREE PLUGS \$38.88 (SAVE \$71.37) | <input type="checkbox"/> 1500 PLUGS & PLUGGER (L006296Y) PLUS 500 FREE PLUGS \$41.88 (SAVE \$73.32)  |
| <input type="checkbox"/> 2000 PLUGS (L006288Y)        | <input type="checkbox"/> 2000 PLUGS & PLUGGER (L006296Y) PLUS 500 FREE PLUGS \$47.88 (SAVE \$99.12) | <input type="checkbox"/> 2000 PLUGS & PLUGGER (L006296Y) PLUS 500 FREE PLUGS \$50.88 (SAVE \$102.12) |

I enclose check or m.o. for \$\_\_\_\_\_ (PA resident's add sales tax)

Shipped "Transportation Collect" the most economical way.

CHARGE TO MY:

- BankAmericard / VISA     Diner's Club  
 American Express     Master Charge  
 Carte Blanche    Interbank No. \_\_\_\_\_

Acc't No. \_\_\_\_\_ Exp. Date \_\_\_\_\_

NAME \_\_\_\_\_ (please print)

ADDRESS \_\_\_\_\_

CITY \_\_\_\_\_

STATE \_\_\_\_\_ ZIP \_\_\_\_\_

© LAKELAND NURSERIES SALES

LAKELAND NURSERIES SALES, Hanover, Pa. 17331

TO KEEP THIS COVER INTACT—USE COUPON ON PAGE 45



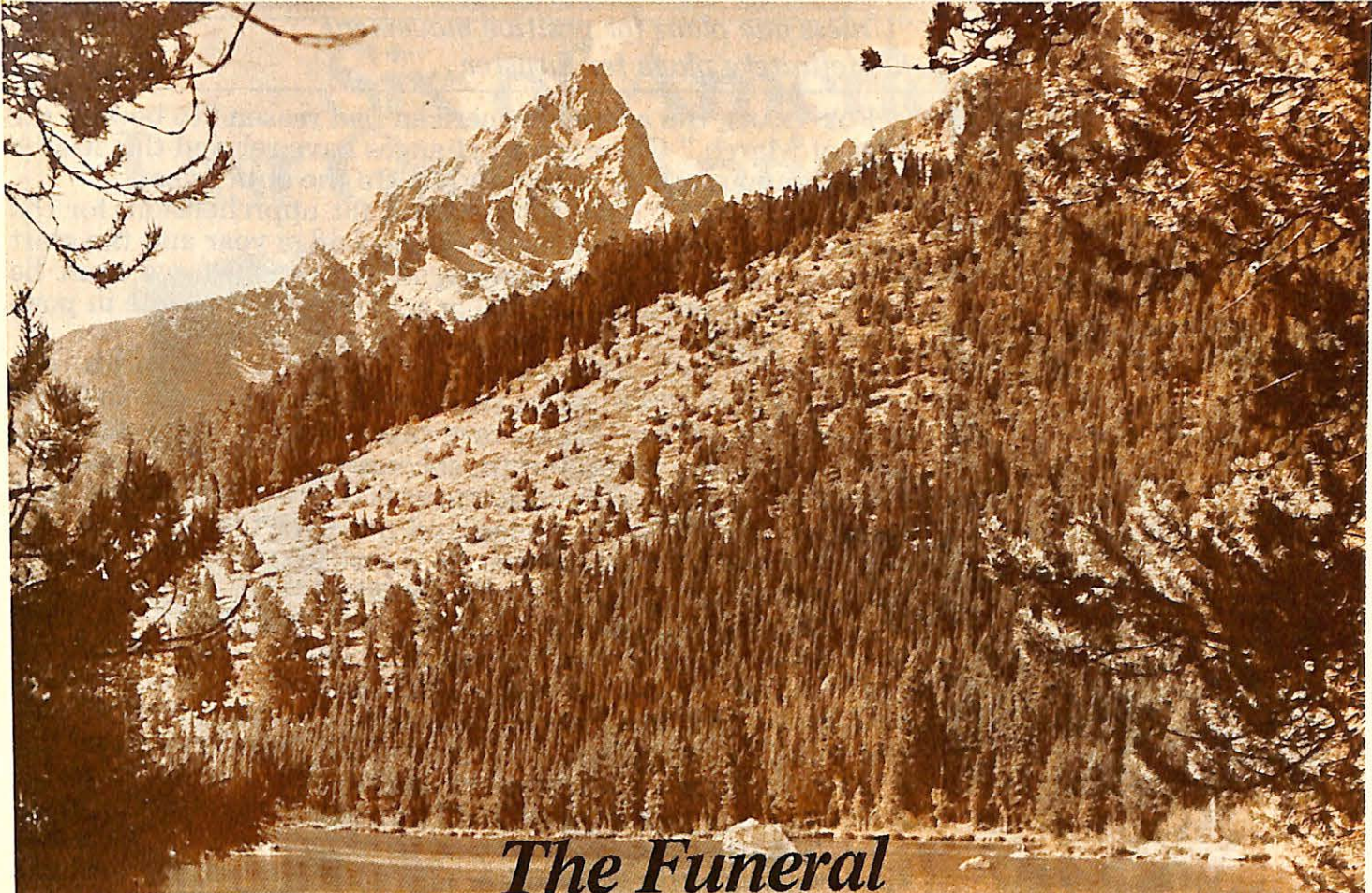

# The Funeral

*It helps you remember the yesterdays.  
And move on to tomorrow.*

*The funeral service fulfills man's age-old wish and need to honor his departed through a dignified ceremony. Determined by custom and culture, the funeral serves a variety of purposes. It symbolizes the beliefs and hopes of society. For many, it is firmly rooted in religious concepts. But, more importantly, the funeral is a service for the living, providing the vehicle for adjusting to a life situation that has been radically altered. In short, the funeral helps persons prepare for the future.*

*Your funeral director is a sensitive and conscientious professional who will assist you in planning the appropriate service to meet your needs. With perception and concern, he*

*will handle the wide range of essential details and arrangements that go to make up a meaningful funeral.*

*As America's foremost manufacturer of quality burial vaults, Wilbert is also a vital part in the funeral service, offering families the very finest in underground protection. For this enduring protection, Wilbert brand name burial vaults are selected by most families nationwide.*

*Send today for a copy of Wilbert's free booklet called "FACTS every family should know," which details, in straightforward language, the information you will find most helpful at the time of a death in the family or of a friend.*



Providing quality when it is needed most



**YES!** Please send me a free copy of "FACTS every family should know"

Name \_\_\_\_\_

Address \_\_\_\_\_

City \_\_\_\_\_ State \_\_\_\_\_ Zip \_\_\_\_\_

WILBERT, Inc.  
P.O. Box 147E  
Forest Park, IL 60130



*"Unless one plans for positive movement,  
he definitely plans for disaster..."*

## A NEW BEGINNING



A  
MESSAGE  
FROM THE  
GRAND  
EXALTED RULER

FOR YEARS, the average American had reason "to beware the Ides of March." Government changes have relaxed this March anxiety and given us reason to beware the entire year.

WE ELKS STILL have some reason for apprehension, for the Ides of March signals the end of one Lodge year and the start of a new one. At the beginning of next month, we must be ready with a new Exalted Ruler and a slate of people in positions of importance and authority in our Lodges.

ALTHOUGH THE EXALTED RULER will come in with his officers already established, he still has an important job to do. It is necessary that he take every precaution in his position to insure his Lodge a prosperous, successful, and happy year.

ONE OF HIS FIRST CONSIDERATIONS is that he must realize that he is the leader of the Lodge and must devote the time and energy necessary to show that he is just that. All too frequently, leadership is confused with dictatorship. The former implies warm, close, personal relationships and assures cooperation, understanding, and success. The latter demands narrow, single-minded operation and begets confusion, distrust, and, at best, a static or retrogressive condition. This we cannot afford; and in order to avoid it, the Exalted Ruler must exercise the greatest caution in his first and most important assignment, selecting those members who will form the various committees.

IN THIS TASK he would do well to remember that he cannot sit down and arbitrarily fill in any name that comes to mind and assign it to a position. Every position is important and deserves thought and consideration. Round holes will never accommodate square pegs, and a haphazard selection will result in just such a condition.

IN SELECTING HIS COMMITTEES, the Exalted Ruler might invoke the chief principle of leadership, which is close personal contact. Each member being considered for such a position should be contacted personally and be made aware of all the responsibilities involved. He should know the duties, purposes, and objectives. Approached in this way, he will remember that he joined the Order to serve and not to be served. As a good Elk, he will do everything in his power to help manage the affairs of the Lodge. Truly, he is one of the group "running things." The group really turns out to be a large, well-represented segment of the Lodge rather than a small "clique." The Exalted Ruler would do well to study his membership and enlist the aid of the new and inexperienced members as well as the aid of the more mature and knowledgeable people.

THE PROCEDURE sounds complicated and, indeed, it is. But the position of Exalted Ruler is not, nor is it intended to be, a glittering, empty honor. It is a position of great responsibility and should be recognized as such. It requires great care, unmitigated effort, and boundless enthusiasm.

PERSONAL CONTACT and warm relationships will accomplish this. Unless one plans for positive movement, he definitely plans for disaster.

*Leonard J. Bristol*

Leonard J. Bristol



# Six of America's Last Great Antique Buys!

Genuine Circa 1900 Antiques.  
When they're gone, they're gone forever!



The Parlor Clock  
\$85.00



The Traditional Schoolhouse Clock  
\$105.00



The Ring Octagon Schoolhouse Clock  
\$120.00



The Original Schoolhouse Clock  
\$115.00



The Classic Double Scroll Clock  
\$115.00



The Fancy Schoolhouse Clock  
\$135.00

All clocks are approx. 22" H, 13" W, 4 1/2" D: except Parlor Clock, approx. 20" H, 9 1/2" W, 4" D, and Traditional Schoolhouse Clock, approx. 19" H, 12" W, 4 1/2" D.

We urge you to take heed. These are truly the last of the Great Old Clocks. At our low price, you may never see these values again. Authentic circa 1900 antique schoolroom clocks, the kind that once ticked happily away in the front parlours, general stores and one-room schools of America's childhood. Lovingly restored and in 100% running order. Each is unique—yours will be numbered, registered to your family or whomever you designate and accompanied by a handsome Certificate of Age and Ownership (suitable for framing). Order now, to avoid disappointment. When these clocks are gone, they're gone forever.

- Clocks, we believe, will appreciate many times in value in the years to come.
- Certificate of age, authenticity and ownership.
- Fully re-conditioned 8-day keywind movement, brass pendulum, key. Counts each hour in deep, melodic tones.
- Finely polished and carefully restored hardwood case, approx. 22" H, 13" W, 4 1/2" D. (Clocks will vary slightly in trim and wood tone.)
- Sturdily cartoned and shipped UPS insured.

Pony Express System, 2986 Navajo St., Yorktown, N.Y. 10598

**FOR FASTER SERVICE ON CREDIT CARD ORDERS**

call (914) 248-7031 9 a.m. to 5 p.m. (E.S.T.)

Visit our Showroom, just 1 hour from N.Y.C.



Pony Express System

2986 Navajo St., Dept. M -327, Yorktown, N.Y. 10598

Gentlemen: Please send me the following clock(s) (state qty.)

- The Parlor Clock (Style 18) @ \$85.00
- The Traditional Schoolhouse Clock @ \$105.00
- The Ring Octagon Schoolhouse Clock (Style 13) @ \$120.00
- The Original Schoolhouse Clock (Style 11) @ \$115.00
- The Classic Double Scroll Clock (Style 15) @ \$115.00
- The Fancy Schoolhouse Clock (Style 12) @ \$135.00

Choice of  Arabic or  Roman Numerals. (Add \$8.50 for each insured delivery.)

If these clocks are to be Gift orders, please attach a separate sheet of paper stating the name the clock is to be registered to, and name and address for shipment. We will enclose a gift card at your request. On multiple orders, be sure to specify who gets which clock.

My check is enclosed for \$ \_\_\_\_\_ (N.Y. State residents add 5% tax).

I prefer to charge my (check one)

American Express       Master Charge       VISA

Acct. No. \_\_\_\_\_ Exp. Date \_\_\_\_\_

Signature \_\_\_\_\_

Mr./Ms. \_\_\_\_\_

Address \_\_\_\_\_

City \_\_\_\_\_ State \_\_\_\_\_ Zip \_\_\_\_\_

Satisfaction Guaranteed



# What do you call 'home'?



House?



Apartment?



Condominium unit?



Mobile home?

Allstate has designed special insurance for each of these special needs. Dollar for dollar, among the best home protection values on the market today.

Whatever kind of dwelling you call "home," come in—to Sears or an Allstate office—and compare our price with what you're paying now.

Maybe we can save you some money.

**Allstate**  
You're in good hands.

It's wise to keep track of what you've invested in furnishings, too.

Send for Allstate's free "Household Inventory Record." Check # \_\_\_\_\_ on this page.

Allstate Insurance Company

Policies available in most states

NATIONAL PUBLICATION OF THE BENEVOLENT AND PROTECTIVE ORDER OF ELKS OF THE UNITED STATES OF AMERICA. PUBLISHED UNDER THE DIRECTION OF THE GRAND LODGE BY THE NATIONAL MEMORIAL AND PUBLICATION COMMISSION.

THE ELKS NATIONAL MEMORIAL AND PUBLICATION COMMISSION

WADE H. KEPNER/Chairman

R. LEONARD BUSH/Vice-Chairman

RAYMOND C. DOBSON/Secretary

EDWARD W. McCABE/Treasurer

ROBERT E. BONEY/Asst. Secretary and Asst. Treasurer

JOHN R. RYAN/Publisher/General Manager

DONALD STAHL/Articles Editor

MARY M. CAVANAGH/Fraternal News Editor

MALCOLM B. CROFFORD/Circulation Manager

EDITORIAL OFFICES, 425 W. Diversey Parkway, Chicago, IL 60614

- |    |   |                 |
|----|---|-----------------|
| 6  | <b>The Loneliest Man in the World</b>   | Frank Thistle   |
|    | Only one prisoner remains in Spandau, the world's most strange, expensive, and secretive prison. He is Rudolf Hess, Hitler's former Deputy Fuehrer. |                 |
| 26 | <b>Jury Duty Calls</b>  | John C. Behrens |
|    | The chances are increasing each year that your time to take a turn on jury duty is closer than you think.   |                 |
| 30 | <b>Seaweed: Miracle Plant of the 21st Century</b>   | Doreen Buscemi  |
|    | In the future, seaweed may feed us when we're hungry, heal us when we're sick, and keep us warm in winter.  |                 |

### Departments

- |    |                                     |    |  |
|----|-------------------------------------|----|--|
| 2  | Message                             | 24 | Major Projects: NE/OH                      |
| 10 | You and Retirement: Dentures        | 29 | Visits of Leonard J. Bristol               |
| 10 | Letters                             | 34 | Elks National Foundation/<br>Joy of Giving |
| 12 | The Elks National Memorial Building | 35 | Travel: Spain                              |
| 14 | A Candidate for Grand Exalted Ruler | 38 | Elks National Service Commission           |
| 15 | News of the Lodges                  | 40 | Elks Family Shopper                        |
| 20 | It's Your Business: Keogh Plan      |    |  |
| 22 | Medicine and You: Diabetes          |    |  |

### Cover: The Elks National Memorial Building

ADVERTISING OFFICES



CHICAGO 60614 425 W. Diversey Parkway (312) 528-4500

NEW YORK 10017 50 East 42nd (212) 682-2810

THE ELKS MAGAZINE, Circulation Dept., 425 Diversey Parkway, Chicago, IL 60614

MEMBERS: Changes of address should be made through your lodge Secretary. Give him advance notice of at least 30 days. Remember that the day you write, your next copy is already in the mails. Before you move, file your new address at the post office to have mail forwarded. In writing to us regarding an address change, please give: Full name, lodge number, membership number, address to which copy is being mailed, and complete new address. Attach label from recent issue if available. Please show ZIP Code numbers in both old and new address.

THE ELKS MAGAZINE, Volume 57, No. 10, March, 1979 (ISSN 0013-6263). Published monthly at 425 W. Diversey Pkwy., Chicago, IL 60614 by the Benevolent and Protective Order of Elks of the United States of America. Second class postage paid at Chicago, IL, and at additional mailing office. Acceptance for mailing at special rate of postage provided for in Section 1103, Act of October 3, 1917, authorized May 20, 1922. Single copy price is 25 cents. Subscription price in the United States and its Possessions, for Elks, \$1.25 a year, for non-Elks, \$2.50 a year; for Canadian and Foreign postage, add \$1.50 a year. Subscriptions are payable in advance. Manuscripts must be typewritten and accompanied by sufficient postage for their return via first class mail. They will be handled with care but this magazine assumes no responsibility for their safety.

The word, Elks, is a registered trademark of The Benevolent and Protective Order of Elks of the United States of America. Copyright, 1979, by the Benevolent and Protective Order of Elks of the United States of America



# Raise as much money as you need!

**Sell a Pen-Pac for \$1  
Keep 50¢ PROFIT!**

Make Big Profits for your school, church, team or civic organization. Here's the easiest fund-raising program around:

- Full 50% profit!
- Free step-by-step manual for fund raising leader!
- No call backs, no order taking, no paperwork!
- Nothing to spoil!
- No heavy bulky packages to carry!
- No hidden costs — we even pay postage!
- NO RISK — Pay only after your fund raising drive is over AND return any leftover Pen-Pacs for full credit!

## Pen-Pacs are a real value!

5 high quality ball-point pens with long-lasting ink supplies and effective ink erasers make up a Pen-Pac. Outside, its handsome blue & white design states, "Thank You for your generous help." It would sell for \$1.45 in any store. You sell a Pen-Pac for \$1.00 and keep 50¢ profit. Since everyone needs and uses pens, your funds really add up fast!

## You Don't Risk a CENT!

Unlike other programs that give you just 40% or less, YOU KEEP 50% of what you've collected. You pay us AFTER your drive is completed. We even pay the cost of shipping your order to you AND you can return any leftover Pen-Pacs at our expense. You risk nothing. *Mail the coupon NOW!*



**Full  
50%  
Profit!**



## Everything You Need is Included!

25 Pen-Pacs come packaged in a lightweight carrying carton. Order 1 carton per member. Also included are contribution envelopes, a "how-to" manual, record-keeping forms, even press releases . . . all designed to guarantee your success.

## Take advantage of our Fund Raising Know-How!

U.S. Pen Company is a division of one of America's leading manufacturers of writing instruments. These are pens you can be proud of. We are. And we'll stand behind them with over 50 years' experience.

## Make BIG Profits — Order Today!

For extra fast service, call toll free 800-631-1068 from anywhere in the continental U.S.A. or mail the coupon below. N.J. residents call 201-227-5100 collect. Do it today.

## CALL TODAY or MAIL THIS COUPON now!

We need to raise .....	<input type="checkbox"/> \$100	<input type="checkbox"/> \$300	<input type="checkbox"/> \$500	<input type="checkbox"/> \$1000
Please send Pen-Pacs .....	200	600	1000	2000
Ship to:				
My Name _____	(please print)			
Organization _____				
Address _____				
City _____	State _____	Zip _____		
My Title _____				
Signature _____				
Telephone _____	<input type="checkbox"/> Please send more information.			
Available in Canada too! Write for information.				
<b>U.S. PEN company</b>				A subsidiary of Cadence Industries Corporation
Dept. FR437, W. Caldwell, N.J. 07006				

Copyright © 1978 U.S. Pen Company, a subsidiary of Cadence Industries. All rights reserved.





# the loneliest man

**Rudolf Hess, Hitler's former Deputy Fuehrer and the only prisoner in Spandau Prison, sits alone in his shadowy cell, howling like a wolf.**

by Frank Thistle

Thirty-two years ago seven men stepped from a van in the red brick courtyard of Berlin's Spandau Prison and were led to separate cells. They were the senior survivors of 22 Nazis brought to trial at Nuremberg for major war crimes. Their compatriots in crime—among them Luftwaffe Boss Hermann Goering and Wehrmacht Chief Wilhelm Keitel—escaped imprisonment by suicide or hanging.

Today, only one prisoner remains in Spandau, the world's strangest, most expensive, most secretive, and most closely-guarded prison. He is Rudolf Hess, Adolf Hitler's former Deputy Fuehrer. At 84, Hess is a haggard, hollow-eyed remnant of the saturnine Nazi fanatic that Hitler named as his successor after Goering. Despite his physical deterioration, Hess has lost none of his air of mystery. To his jailors, he remains an enigma, a strange one, carrying behind his dark, brooding eyes answers to questions that still tease historians.

On the night of May 10, 1941—as Hitler's triumphant armies stood poised on the French coast looking toward England—Hess astounded the world by parachuting into Scotland. Allied leaders found the visitation no less mystifying than did the Scottish farmer who rounded up Hess in his meadow.

According to the official British version, Hess claimed he had come over on a "mission of humanity." He wanted to convince the British they had lost the war and should make peace immediately. Hess said Hitler favored peace without "oppressive demands" on Britain. But if his terms were rejected, he intended to lay waste and subjugate the island nation. Among Hitler's conditions were no negotiations with Prime Minister Winston Churchill.

Churchill was enjoying a Marx brothers movie when told of Hess' descent on Britain. Reluctantly, the Prime

Minister switched attention to what he regarded as another farce. Churchill accepted Hess' statement that he made the flight on his own initiative. He wrote of it later as an "escapade" of no importance to the course of the war.

Josef Stalin disagreed. The Russian dictator declared that Hitler was trying to rally the United States and Britain against Russia and that Hess was sent to England as part of the plot. German officials discounted reports that Hess went to Britain on Der Fuehrer's secret orders. Hitler seemed enraged by the episode. He ordered the name of Rudolf Hess, once his inseparable confidant, blotted from the public record.

Explained the German Foreign Office: "The Deputy Fuehrer became 'the victim of hallucinations,' one with 'the fixed idea that he was a sort of messiah who, by a spectacular individual gesture, could bring about the termination of hostilities.'"

In October 1946, Hess' "mission of mercy" did not deter the Allied War Crimes Tribunal at Nuremberg from sentencing him to life imprisonment for "plotting against peace and planning, inciting and carrying through aggressive war." A prison psychologist told the court: "There is no indication that Hess was insane at the time of the activities for which he has been indicted. Hess is not insane but suffers from hysterical amnesia."

Rudolf Hess was born in Alexandria, Egypt, on April 26, 1894, the son of a German wholesale merchant. He attended school there and his lessons were supplemented by a tutor. He was a "wanted" child and his relationship with his parents was always good. The Hesses were a well-off family, enjoying a distinguished position in a large German community. At 12, he was sent to Germany to attend school at Godesberg am Rhein. At 17, he enrolled in a business school in Switzerland. After

a year, he went to Hamburg to join an export house and serve his apprenticeship for his planned third-generation Hess role as an importer-exporter.

In 1914, when the war broke out, he saw his chance to break away. He volunteered and was accepted in the 1st Bavarian Regiment. During fighting on the Western Front he sustained the first of three war wounds, none of them serious. He was commissioned as a lieutenant and in the first year of the war transferred to the Air Corps where he got his first taste of flying.

At the end of the war, Hess entered Munich University and studied history, economics, political science and geopolitics, the study of the effect of geographical position on a nation's life. His geo-politics professor often peppered his lectures with references to the influences of astrology and the supernatural on Germany's history. They had a profound effect on Hess. The 24-year-old Hess felt keenly about the position in which Germany found herself after the war. He was angry about the poverty and the apparent injustice. He dreamed of Germany becoming great once more.

He mixed eagerly in the political life of the university. He distributed anti-Semitic pamphlets and brawled in the beerhalls with various armed bands he linked up with. In 1920 he went to a meeting of the Nazi party, heard its fiery Hitler speak, and was enthralled. Captivated by what the shouting, gesticulating man said, Hess joined the Nazi party. It was only a short time before Hitler's attention was drawn to new member Hess. The university student had written a thesis outlining the type of man who must lead Germany back to power. When Hess' thesis was shown to Hitler he preened and congratulated Hess on his insight.

Hess gave Hitler his loyalty and followed him with a dog-like devotion.



in the world

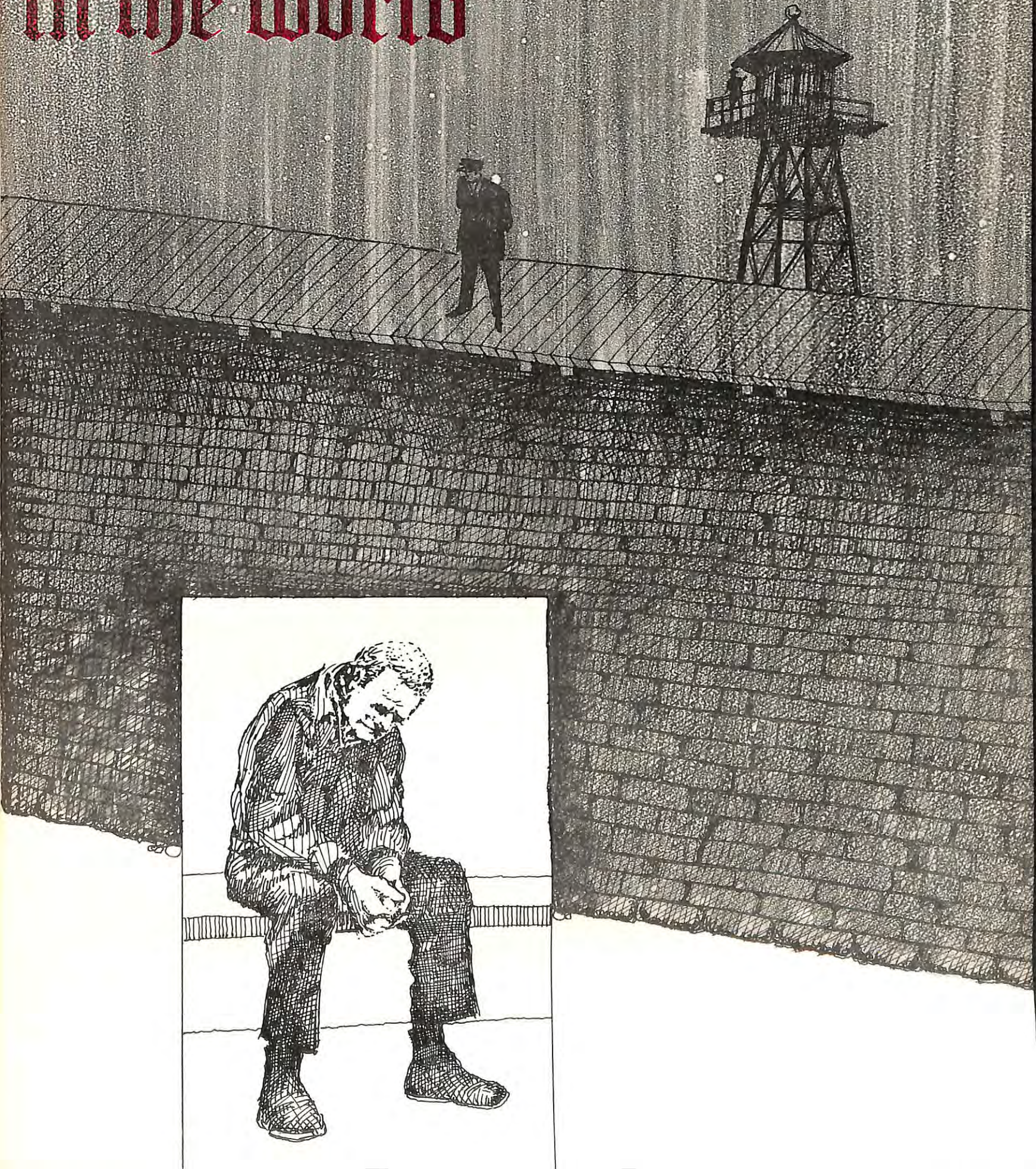



# the loneliest man in the world

His first big chance to show his loyalty was in the Munich beer-cellar putsch on November 8, 1923. After its failure, both he and Hitler were tried. Hitler was jailed for five years. Hess got 18 months, and the two found themselves in the Landsberg prison. Here Hitler started *Mein Kampf* and Hess agreed to help edit his manuscript.

When Hess and Hitler were released just before the end of 1924, having served only a few months of their sentences. Hess had become, in effect, Hitler's private secretary. On July 20, 1929 he was appointed personal adjutant to Adolf Hitler. In 1932 Hitler appointed his adjutant head of the Party's central political commission where he supervised the political activities of the Nazi factions in the State Assembly and helped determine questions of general political strategy.

On April 21, 1933 came a still higher honor: "I hereby name to be my deputy, the leader of the central political commission, Party member Rudolf Hess, and give him all the powers of attorney in all questions of decision of the Party leadership to be decided in my name"—Adolf Hitler. Hess was dominating Party control of universities, schools and religious societies. He was busy organizing the labor front, and in 1935 he put his name to the ominous Jewish legislation that was to play such a terrible part in Hitler's dictatorship. Three years later he moved into Hitler's Secret Cabinet Council that was busy planning foreign aggression.

Today, within Spandau's secretive walls, a prison source who observes Hess nearly every day says the former Nazi leader lives in a morose dream world.

"He no longer takes an interest in politics. I believe he wants to forget the past. He won't read newspapers or books, except those on astrology, which he reads avidly."

Until 1969, Hess declined visits by his wife, son or other relatives. Prison rules allow him one 30-minute visit a month by a relative.

"My family shall see me again only under normal circumstances," Hess once told a guard. However, he does not conceal his longing to rejoin his family when he writes letters which are censored by prison officials.

Hess lives in one of Spandau's four cell blocks designed to house 660 inmates. More than 100 guards and other attendants watch his movements day and night. Frequently, in the middle of the night, Hess bursts into wild outcries, usually complaining of abdominal pains or the light which prison

rules require be flashed on in his cell every two hours to guard against suicide attempts. Once he tried to commit suicide by swallowing garden insecticide. When he is roused at 6 a.m., Hess sometimes doubles over complaining of stomach pains and refuses to get out of bed.

"He takes a special pleasure in worrying the warden," says a prison guard. "One never knows whether he is really ill or just pretending. By 8 o'clock he is supposed to be working in the vegetable garden. But he usually refuses to work."

Control of the prison rotates month to month among the United States, Britain, France and Russia. When the western forces are in control, they wink at Hess' antics and let him go pretty much his own way. But the Russians insist Hess do his gardening. If he throws a tantrum, the Russians lock him up in his cell.

Hess came back into the public eye not long ago when he called his lawyer and made his will. His lawyer claims Hess is not insane. Psychiatrists disagree on this point. Some say he is perfectly normal. Others insist he is psychotic.

Laymen also disagree. Guards say he sometimes seems sane and at other times he appears to be under a hallucinatory spell. There is no doubt that he is a hypochondriac and suffers from half a dozen imagined ailments. He is also eccentric and mean in petty ways.

Hess has alienated the Spandau staff for many years by begging new guards for a smoke—which he is not supposed to do—and then calling the warden to exhibit the butt while gleefully relating that the guard has broken the rules. He sings Nazi songs in his cell, goes on brief hunger strikes, and still praises the greatness of Hitler.

His mental state has not improved with the years. Some nights he howls

Frank Thistle recently won five first-place awards at the 18th annual awards competition of the San Fernando Valley Press Club, setting a record for the number of first-place awards won by an individual. Two of Mr. Thistle's winning entries appeared in *The Elks Magazine*: Best In-Depth Reporting, "Loneliness: America's Newest Killer" (June, 1978) and Best Feature Story, "Irving Lazar: The Peerless Prince of Pitch" (May, 1978).

like a wolf in his cell. Soldiers on guard can hear him plainly and sometimes they get so fed up with it that they howl back at him.

Allied intelligence agents are constantly picking up rumors that Nazi diehards plan to free Hess in an escape plot. But Spandau is as escape-proof as a prison can possibly be. The Teutons who built the fortress ringed the inside with a row of walls, which were later redesigned into cell blocks. The inner block, where Hess is incarcerated, is sealed off from the other blocks. Cell windows are barred and are high above reach.

Spandau has no side or back exits and its only entry to the outside is through the front gate. Atop the massive outer wall are electrically charged barbed-wire barriers that kill upon touch. Guards armed with machine guns are stationed in the lookout towers. Every 15 minutes a report comes from each lookout post to the central prison office. Guards constantly scour the area around the prison for signs of activity.

The prison is one of the last operations to be jointly managed by the countries that fought Germany in World War II—the U.S., the Soviet Union, Great Britain and France. Each of these powers take monthly turns supplying guard troops. In addition, Spandau has a staff of about 300, including permanent jailers, administrative personnel, cooks, laundry workers and medical personnel who operate a fully-equipped lab and hospital. With this small army guarding him, Hess has little chance of getting away with anything.

Hess is not called by name but by number. When he came to Spandau and was told he would be given a number, he demanded to be called "Number One." To deflate him, he was given the last number, "Number Seven." He has never forgiven his captors for this insult.

Although Hess delights in irritating his guards through petty mischief, he is careful not to act overbearing toward his jailers. Normally, he ignores them by his sieges of amnesia and his spells of "deafness." He is often punished for disobedience by being deprived of writing and visiting privileges. But such punishments don't disturb him. He often doesn't even bother to write the one monthly letter he is permitted to send out.

Mrs. Ilse Hess, who runs a lodge in a mountain area south of Munich, says she keeps in touch with her husband by "telepathy." This telepathy has been going on supposedly since 1941, when her husband was in British confinement.

(Continued on page 34)



# Portable refrigeration breakthrough makes ice chests obsolete!

**New Solid State Refrigeration Modules no bigger than your watch, have More Cooling Power than a 10 lb. Block of Ice.**

Your ice chest is bulky, awkward to carry, messy and inefficient at keeping its contents cold. You have to buy ice every day, if you can find it, throw away the spoiled soggy food and drain off the water repeatedly.

Conventional portable refrigerators are either too heavy, too noisy, drain your battery too quickly or need to be kept level.

These problems and inconveniences have finally been resolved in one totally new product - the Koolatron 12 volt portable electronic refrigerator. We believe the Koolatron portable represents such a dramatic advance in refrigeration for recreational use that all existing methods are now outmoded.

## USES AEROSPACE REFRIGERATION MODULES

The Koolatron portable cools your food electronically with solid state thermoelectric refrigeration modules. These same powerful modules are used by military and aerospace scientists to cool critical components in rockets and satellites. They use thermoelectric cooling because of its absolute reliability, insensitivity to motion or level, small size & weight and minimal battery drain.

## WHY IS THE KOOLATRON PORTABLE SO MUCH BETTER THAN AN ICE CHEST?

An ice chest maintains an air temperature of 50-60 deg. F. Meat and milk spoil rapidly at temperatures above 50 deg. F. which is why the top of your meat will go bad even when it is sitting on ice. Koolatron portables maintain normal home refrigeration temperatures of 40-45 deg. F. even in 95 deg. F. weather.

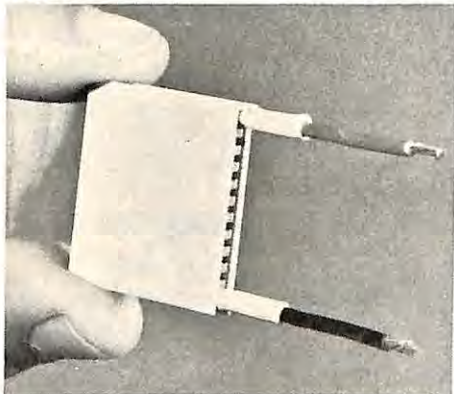

Two of these miniaturized thermoelectric modules replace all the bulky complex piping coils, compressors and motors in conventional portable refrigerators. The modules pump heat from your food into efficient heat sinks where it is dissipated by a quiet fan. They operate on a principle called the "Peltier Effect" - passing electricity through the junction of dissimilar metals causes heat to flow away from the junction.



## THE ULTIMATE PORTABLE REFRIGERATOR

**It weighs less than most coolers with a block of ice but holds over 40 pop cans or 40 lbs. of food in its large 36 qt. capacity. Plug it in a lighter socket in your car, boat or van or operate it from a 12 volt battery charger plugged into 110 volts. Cold contents will stay cold overnight with unit off. Draws a maximum of 4 amps., averages about 2 amps. at 70 deg. F. with the thermostat on. Keeps your food cold and dry. Exterior dimensions are 21" L x 16" W x 16" H. Interior dimensions are 16" L x 11-1/2" W x 12" H.**

## BOATING, FISHING, CAMPING, HUNTING

Fits into virtually any boat, van or camper. Carry it on the back seat during car trips. Ideal for fishing and hunting - bring your catch back home fresh (a few loads of fish fillets could pay for your portable). Use it for grocery shopping, medicines, carrying film, salesmen's samples. Take it to the drive-in movies, auto races and other sporting events. With an inexpensive battery charger you can use your Koolatron as a bar fridge all winter and a patio fridge in the summer. Run it in your motel room at night and enjoy a midnight snack whenever you feel like it. We have customers using our portables on construction sites, in workboats, laboratories and even in locker rooms for a "cold one" after the game.

## BUILT-IN QUALITY AND DURABILITY

The rugged "ABS" case is filled with the best insulation available - rigid urethane foam. It has a "150 lb. test" handle and non-rusting polypropylene hinge and latches, with stainless steel fasteners. The exterior is harvest gold with a white interior and has 4 non-slip rubber feet. Your portable comes with a 9 ft. detachable cord which plugs into your cigarette lighter. It also has terminals for attaching wires directly from a battery



or fuse panel. The same terminals are used for your battery charger clips when operating from a charger. A reverse polarity warning light & buzzer are included. The Koolatron was designed so that the fan motor can be replaced by you with only a screwdriver. No other service should ever be required except for physical damage which can be repaired at our depots in Batavia, N.Y., or Barrie, Ontario..

## ONE YEAR WRITTEN GUARANTEE

Your Koolatron comes with a written 1 year guarantee plus complete instructions and helpful information about batteries and chargers.

## 21-DAY MONEY-BACK TRIAL PERIOD

Use your Koolatron portable for 21 days after you receive it to be certain it is suitable for your application. If for any reason you are not totally satisfied, return it for a prompt refund in full.

## BUY FACTORY-DIRECT AND SAVE

Because of increased sales, our regular factory-to-you price of \$169.00, is now reduced to \$159.00 + \$5.00 shipping (\$179.00 in Canada).

## ADJUSTABLE THERMOSTAT OPTION

For an additional \$10.00 you can order the Koolatron portable with an adjustable thermostat in place of the standard fixed temperature thermostat - order Model F1A.

## PAYS FOR ITSELF

If you are regularly using ice, your Koolatron portable will pay for itself with the money you save on ice, spoiled food, restaurant bills and the gasoline used looking for ice.

## Don't Waste Another Dollar on Ice!

Phone your order in collect to

**705-737-0842**

Koolatron Industries Limited,  
56 Harvester Ave., Batavia, New York 14020

Or use this handy order coupon.

**Koolatron**  
INDUSTRIES LIMITED Dept. 405  
56 Harvester Ave., Batavia, New York 14020  
Canada: 230 Bayview Drive, Barrie,  
Ontario L4N 4Y8

Send me \_\_\_ Koolatron F1 @ \$159.00 (\$179.00 in Canada) + \$5.00 each for delivery in USA or Canada. (N.Y., Ont. and Que. residents add sales tax.)

\_\_\_ I want model F1A and have added \$10.00. I understand that I may return it undamaged within 21 days and get a full refund if I am not satisfied. I enclose my  check  money order for \$\_\_\_\_\_ or, please charge my  Visa  Mastercharge  American Express.

Acct. No. \_\_\_\_\_

Expiry Date \_\_\_\_\_  Send brochure only

Signature \_\_\_\_\_  
necessary to ship merchandise

Name \_\_\_\_\_

Address \_\_\_\_\_

City \_\_\_\_\_

State \_\_\_\_\_ Zip \_\_\_\_\_





# YOU AND RETIREMENT

by Grace W. Weinstein

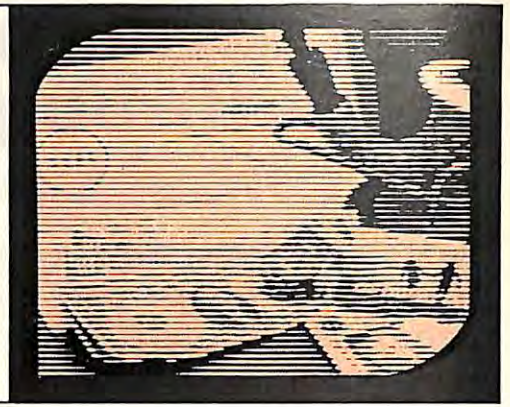

• I remember when I joined the Elks in Yakima, WA, back in 1922. I'll never forget the initiation. They asked all of us who wanted to donate \$100 for the new Elks dining room to stand up. Of course, we stood up—our seats were wired!

By the way, many of us wondered what happened to the 3 million men who served in the Civilian Conservation Corps from 1933 to 1942. . . so last summer, some 500 former members of the CCC from 39 states met in West Sacramento, CA. We organized the National Association of Civilian Conservation Corps Alumni (NACCCA). We are trying to locate the ex-CCC boys who did so much for their country in the Great Depression. We have found over 10,000 of them, but still have over 2 million to locate.

Anyone who served in the CCC, in any capacity, is eligible to join NACCCA. For details, please write me.

Jack Vincent  
1709 Michigan  
West Sacramento, CA 95691

• The article on mushrooms, "For the Love of Fungus," (January, 1979) by John Grossmann, not only interested me, but may interest many others.

A point I'd like to make is that there are over 38,000 known species of mushrooms, a large portion of which are poisonous. The *amanitas*, for instance, are widespread and contain several very poisonous species. Readers should be cautioned that only skilled persons can tell which mushrooms are safe and which contain a deadly poison.

Dennis M. McLaughlin  
Lynchburg, VA

• Regarding the letter that appeared in the "Letters" column (January, 1979) from Thomas E. Biggert—he didn't mention the newly-formed Elks Collectors Club, of which he is a member.

Brother Richard J. S. Hale, a member of the Oceanside, CA, Lodge, has formed a club for those who collect B.P.O.E. memorabilia. Our first Memorabilia Newsletter was in the Christmas mail.

Among the informative and interesting articles was the true story of how and where "Hello Bill" was derived.

This could develop into a very large and exciting club. Besides the California members, we are also from Iowa, Texas, Kansas, and Nebraska. Anyone who would like information about joining us, please write: Richard J. S. Hale, 3401 Rollsrinch Dr., San Diego, CA 92111.

Mr. & Mrs. Wesley Norton  
Muscatine, IA

Letters must be signed and may be edited. Address to: Letter Editor, *The Elks Magazine*, 425 West Diversey, Chicago, Illinois 60614.

## DENTURES

The percentage of Americans wearing dentures is dropping dramatically, according to new data just released by the American Dental Association, largely because of advances in preventive and restorative dentistry. But significant numbers of older Americans are wearing dentures or should be wearing them. The Federal Trade Commission recently issued a report noting that 40% of America's older population has ill-fitting or incomplete dentures, and that 25% of all Americans over 65 need to have complete upper or lower dentures but are unable to get them because they cost so much.

Missing teeth definitely need to be replaced. If even a single gap is left in your mouth, other teeth may shift and loosen, food may get caught, and disease may develop. A single missing tooth may be replaced by a bridge. When large numbers of natural teeth are past saving, an adequate diet becomes almost impossible, and partial or complete dentures may be the only answer.

Traditionally, only dentists have been legally permitted to work in the mouth. Cost-conscious consumers, however, among them older adults desperate for new teeth, have sought other alternatives. One such alternative is having dentures fitted, often illegally, by a denturist or dental technician.

Now, amidst considerable controversy, open war has erupted between dentists and denturists. An Oregon law, passed in November, 1978, permits denturists to fit dentures in a patient's mouth. Previously, denturists did the laboratory work but were not allowed to make the impressions or do the actual fitting. Senior citizen advocates, who pushed very hard for the new Oregon legislation, claimed that dentists paid the laboratory approximately \$120 for a set of dentures and then charged the patient about \$600. The new legislation, proponents say, will put false teeth within financial reach of the people who need them.

But Oregon dentists do not agree. Neither do dentists in other states, and the war is far from over. The issue, according to the denturists (who have organized in the National Denturists Association, based in Denver), is simple: patients can get less-costly dentures from a denturist, and they can get dentures made and fitted by a specialist, someone

who does nothing else. The issue, according to the American Dental Association, is one of training and of complete patient care. Training to make dentures is not training to fit them in the human mouth, says the ADA, any more than pharmaceutical training to fill prescriptions is training to diagnose and prescribe. After-care, furthermore, is very important; tissues continue to change and dentures must be adjusted, while overall oral health must be evaluated.

If you don't want to use a denturist or, more likely at this writing, don't have access to one, there are still some other cost-saving options. The American Dental Association, in an effort to combat charges that prices are far too high, has established referral services in a number of states. Your local or state dental society can tell you if it has a list of dentists who will provide dentures at lower-than-usual costs. Some dental school clinics also offer dentures, along with other dental services, on a sliding scale fee basis. One, the New Jersey College of Medicine and Dentistry, has just opened the first no-cost denture center for low-income people who are not eligible for Medicaid. And group dental practices, sometimes specializing in dentures, offer another alternative to high prices, one without income limitations. One such group, the New York-based (but expanding) Denture Center, has an on-site laboratory and offers single-session fitting.

It's important to keep costs down. It's also important to guard your health. It is possible to fit dentures in a single sitting, but follow-up visits may still be necessary; such visits may be difficult to arrange with an out-of-town or one-stop clinic. It is possible to have "immediate" dentures, but you should know the advantages and disadvantages.

Immediate dentures, fitted to the mouth right after extraction of the natural teeth, do offer some plus factors. You will never, for one thing, have to appear without teeth. The form, size and arrangement of your natural teeth can more easily be duplicated while some of your own teeth remain in your mouth. There is less discomfort with immediate dentures because they act as a bandage, reducing bleeding and cushioning the extraction sites from food. Speech patterns and eating habits do not have to be relearned.

(Continued on page 25)



# You worked hard most of your life. Now your age can work for you.

AARP is an organization created exclusively for people 55 or over. Its main purpose is to keep vital people in the forefront of life, participating and contributing. Profitably.

AARP stands for the American Association of Retired Persons. It is non-profit and non-partisan. For people retired or not, active or not, healthy or not so healthy. There are now almost 11 million members across the country who are taking advantage of their age. Through AARP.

For only \$3.00 a year, you and your spouse can join AARP and take advantage of all its unique benefits and services.

## Meet with people your own age.

At over 3,000 Local AARP Chapters across the U.S. people are meeting to improve the quality of their lives, to make new friends and get involved.

## Travel Service and Group Tours.

Whether you want to travel around the world, or across the country, AARP's recommended Travel Service helps you do it right. Choose from a wide variety of high quality tours and cruises. Luxury or economy and escorted by experienced tour directors, as well as get significant discounts at fine hotels and motels and special car rental rates at Hertz and Avis.

## Pharmacy Discounts and Service.

AARP's 11 million members provide the buying power that gets you prescriptions and over-the-counter medicine at discount prices. Also they're mailed to your home, postage paid.

## Health and Auto Insurance.

Unfortunately, medicare may not cover all your needs. Therefore, one of AARP's most important benefits is eligibility for a Group Health Insurance Plan. Also available is a skilled Nursing Facility and Home Nursing Care Plan, plus you'll receive information about life, home owners and an auto insurance plan that's designed especially for people 55 and over.

\* Membership dues include \$1.40 for annual subscription to Modern Maturity and \$.60 for the AARP News Bulletin.

**"AARP showed David and me that being over 55 had advantages we never dreamed of."**



## Job Opportunities

Being retired doesn't mean you can't work. Mature Temps, an AARP recommended service in many major cities may be able to help you find part-time or temporary employment. This special service like many of AARP's is free.

## Government Representation.

AARP's legislative program represents your particular best interests with state legislatures and Congress. 11 million AARP members make their voices heard for all those 55 and over.

## Community Involvement

At Local AARP Chapters you can find ways to help your community and yourself through Defensive Driving Courses, Consumer Information Desk and The Tax Aide Program.

## Important Reading

AARP provides new members with a series of booklets that guide retired people through areas of particular concern. And when you join AARP you automatically receive two subscriptions. One to Modern Maturity, a full color bi-monthly magazine and one to AARP News Bulletin. Exclusive AARP publications with a variety of news and features of special interest to you.

## How to Join AARP

Just fill out the coupon below and send \$3.00\* for one year's dues. It's that simple. The coupon immediately enrolls you to take full advantage of all the AARP benefits and services. There's only one requirement. You must be 55 or over, retired or not. If you are, welcome to the club.

# JOIN AARP

1909 K Street, N.W., Washington, D.C. 20049

Gentlemen: I am 55 or older:

Please enroll me as a member of AARP. I understand that it makes me eligible for all AARP benefits and privileges.

Enclosed find  \$3 (one year dues)  \$8 (3 years dues)  Bill me later.

Name \_\_\_\_\_ DGPJ

Address \_\_\_\_\_

City \_\_\_\_\_ State \_\_\_\_\_

Zip \_\_\_\_\_ Birthdate \_\_\_\_\_

One membership makes both member and spouse eligible for all AARP benefits and privileges, however, only one may vote. Please allow 30 days for delivery of your membership kit.



# The Elks National Memorial Building

The Elks National Memorial and Headquarters Building is visited by thousands of people each year, and it has become a Chicago landmark since its dedication on July 14, 1926. This awe-inspiring structure, with its beauty and grandeur, is considered by many experts to be the finest of its kind in the world.

Originally erected in memory and tribute to Brother Elks who sacrificed their lives for our country in World War I, it was rededicated on September 8, 1946, in honor of those who served and died in World War II. The address of rededication was delivered by United States Senator Alben W. Barkley of Paducah, Kentucky, Lodge No. 217.

Then on July 4, 1976, a ceremony was held to commemorate America's Bicentennial and the rededication of the Elks National Memorial Building (in its Golden Anniversary year), recognizing those who served and died in the Korean and Vietnam conflicts.

The cornerstone of the Elks National Memorial Building was laid on June 7, 1924, with ceremonies fitting the occasion.

The Elks National Memorial and Publication Commission had invited seven of the most distinguished architects in the United States to participate in a competition to be held under the rules of the American Institute of Architects. After careful consideration, the design submitted by Egerton Swarthout of New York was unanimously selected as the most beautiful and appropriate.

The central unit of the structure is circular and massive in proportions, with a flattened dome 115 feet above the main level. Entered by a single great arched doorway, entirely encircled by a stately colonnade, just below which is a belting frieze carved in high relief, this central building constitutes the distinctively memorial feature of the edifice.

On the north and south of this circular unit, and connected with it by gracefully columned passageways, are wings containing two levels of offices for administrative use. In the front end

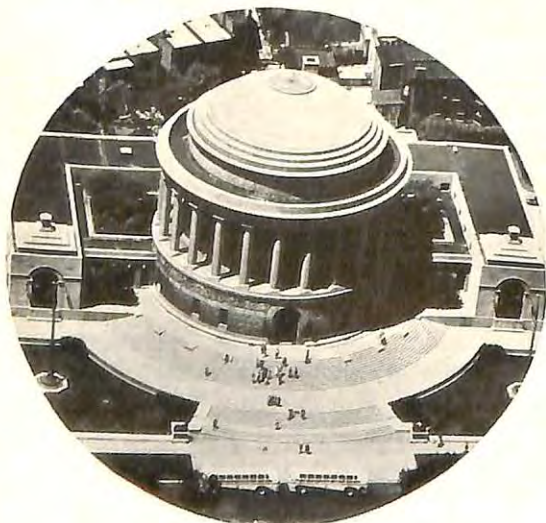

*Highlights of The Elks National Memorial Building (above) include the bronze group sculpture entitled, Patriotism (top), the magnificent Memorial Rotunda (right), and the beautiful Reception Room (far right).*





of each wing stands a statuary group of heroic proportions.

An important and interesting part of the visitor's tour through the Memorial Building is the Archives Room, containing Elks memorabilia of all kinds, some dating back 100 years. Included in this collection is a complete display of State and National Convention badges, as well as other outstanding relics and mementos of the history of the Benevolent and Protective Order of Elks.

Outside, the approach to the main entrance is made between massive stone pedestals, each of which supports a life-sized reclining elk in bronze. Facing each other in postures of dignified repose, these representations of the gentle and graceful animal from which the Order derives its name are strikingly faithful to the living models used, and symbolically indicate the fraternal significance of the shrine. This fitting introduction to the Memorial is the work of Laura Gardin Fraser, who was then widely acclaimed as America's foremost artist of animal sculpture. It was awarded first prize at the 1928 Exhibition of the National Arts Club in New York as the best work of art by a woman in either painting or sculpture produced in 1927.

The terraced flights of steps are flanked by grassy lawns, in the centers of which rise graceful flagstaves that spring from elaborate bronze fascces. From these twin staffs the American flag waves emblematic of the loyal patriotism of the Order's membership.

Within the niches of the facade of the administrative pavilion are the heroic bronze groups of Adolph A. Weinman. Without a superior then among the world's living sculptors, Mr. Weinman is seen at his best in these groups,

which are entitled, respectively, *Patriotism* and *Fraternity*.

The arched doorway and great bronze doors afford the only access to the building from the front. The design is elaborately ornate, cast in duplicate with heavy plate glass between, thus presenting the same finished appearance of open work from within and without; yet the essential effect is that of strength. These doors, in striking contrast to the plain stone facing in which they are set, constitute one of the outstanding art features of the Memorial Building. They are the product of the Gorham Studios and have been accorded recognition as among the finest examples of portal architecture.

In every direction there is marble. The interior facing of the main walls and corridors, the great floor, the 24 huge columns forming an interior colonnade 27 feet above the floor, the 44 columns marking the corners of the arcades leading to other sections of the building, the graceful balustrades protecting the stairways to the rooms below, the stairways themselves, the contrasting entablature and molding around the walls—all are of marble.

Varying from darkest green and richest chocolate brown to the most delicately tinted light blues and lavenders, exquisitely carved and perfectly polished, the marble is a feast to the eye.

Uniformly spaced about the circular hall are four niches. In each, elevated upon an altar-like pedestal, stands a statue of gilded bronze. These symbolize the four cardinal virtues of the Order: *Charity*, *Justice*, *Brotherly Love*, and *Fidelity*. These significant figures, of heroic size, are the work of James Earle Fraser, one of America's foremost sculptors. Admirably conceived to express their meaning and executed with

perfect skill, they would find a welcome place in any of the world's great art galleries.

Between each pair of the upper columns is a tall window of art glass, designed and colored to harmonize with the whole, while furnishing a softly filtered light to the interior of the Memorial Hall.

Alternating with the windows are 12 large panels containing a series of allegorical mural paintings from the hand of Eugene Savage. The number and size of these paintings presented a gigantic task upon which Mr. Savage was engaged for several years. Additional mural paintings were created by Edwin H. Blashfield.

North and south, leading from the main hall into the passageways to the administrative pavilions, are short corridors marked at each corner by twin columns of tinted marble. Flowing arched portals and ceilings blend nicely with the general design of the rotunda. These effectively frame vistas of rare architectural charm and beauty.

Through the west arcade, directly opposite the main entrance of the building, one passes into the great reception room. It is second only to the Memorial Hall in impressiveness; and, despite its size, possesses a charming atmosphere of warmth and luxury.

The specially designed furniture, which contributes to the effect, includes two massive walnut tables of exquisite grain and finish, matching high-backed chairs, and tall lighting standards in wood and bronze. Large Oriental rugs in beautiful patterns and colors adorn the floor.

A touch of brilliance is added by four chandeliers of crystal and bronze, proportioned to the spaciousness of the room and providing adequate night illumination.

Three large windows of art glass, designed and tinted to sustain the general effect, are set deep in the west wall. They provide the soft daylighting of the whole interior. Contrasting with the dark woodwork all around, they are striking features of this unusual room.

The most distinctive part of the reception room is the arched ceiling which is divided into deep panels of varying sizes and shapes. Here again, Eugene Savage excelled artistically with a generous use of gold leaf and rich colors to create a fine harmony with the dark woodwork.

A special invitation is extended to all Elks and members of their families to visit this magnificent structure. Uniformed guides conduct tours from 10:00 A.M. to 5:00 P.M., seven days a week (closed Christmas and New Year's Day only). Special arrangements can be made for large groups by calling 312-528-4500.





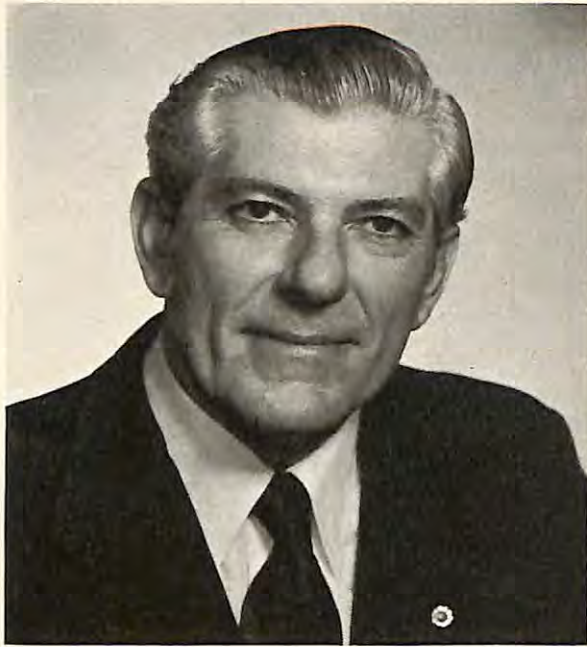

**North Palm Beach,  
Florida,  
Lodge No. 2069  
Presents  
Robert Grafton  
For Grand Exalted Ruler**

North Palm Beach, Florida, Lodge No. 2069 of the Benevolent and Protective Order of Elks, at its regular session on December 18th, 1978, unanimously resolved to respectfully present the name of its distinguished member, Robert Grafton, for the office of Grand Exalted Ruler for the year 1979-1980.

Brother Grafton was born in Cleveland, Ohio, on March 5, 1927. When he was 4 years of age, the family moved to Florida, and that has been his permanent residence. He attended school in West Palm Beach, Florida, graduating from St. Ann's High School in 1944. He attended Palm Beach Junior College and the University of Florida, College of Law, graduating in 1950 with a Bachelor of Laws degree from the latter institution, and is admitted to the practice of law before all Florida Courts and the Federal District and Circuit Courts of Appeal.

From 1950 to 1956 he practiced law in West Palm Beach and, during this period, served as City Prosecutor and Municipal Judge of that city.

Early in 1956 he became Attorney for the Central and Southern Florida Flood Control District (now known as South Florida Water Management District), a special district formed for the purpose of water management in the central and southern part of Florida. The area encompassed by the District comprises 17,400 square miles, a land area about the size of the States of Connecticut and New Jersey combined. In 1959 he became District Counsel for the District and has continued in that capacity to the present time. His respon-

sibilities have included complete legal representation and a land acquisition program involving the expenditure of approximately 50 million dollars. Several Governors of Florida have appointed him a member of special water resources study committees initiating and reviewing Florida water resource laws. In 1968 he was elected Chairman of the Southern Water Resources Conference, an organization of administrators involved in water resource activities.

Brother Grafton has served his community by coaching a little league baseball team for 9 years; served 5 years (2 as Chairman) on the Planning Board of the City of Riviera Beach, Florida, and 10 years as Chairman of the Zoning Board of Appeals of Riviera Beach.

His official affiliation with our Order began with his initiation in July of 1948 into West Palm Beach, Florida, Lodge No. 1352, but his father and grandfather were members and he had been a member of the Antlers organization.

Upon return to West Palm Beach from college, he became active in the West Palm Beach Lodge and, after serving in 5 Officer's chairs, became Exalted Ruler in 1957. During that year his Lodge was judged best in the state in Youth Activities, as well as State Ritualistic Contest winners and finished 5th amongst 38 teams in the National Contest in New York City. He became a certified ritualistic judge in 1958 and coached his lodge team to the position of second in the Eastern Division in both 1959 and 1960.

During the latter part of his term as Exalted Ruler, he participated in the

institution of a new lodge in an adjoining community. That lodge is North Palm Beach Lodge No. 2069, to which he demitted in 1961 and for which he served as Exalted Ruler in 1962-63.

The Florida State Elks Association has been the beneficiary of his service in many capacities, including that of President, and presently he is a member of the Operating Board of its major project, Harry-Anna Crippled Children's Hospital.

He served as District Deputy Grand Exalted Ruler, Special Deputy Grand Exalted Ruler and 4 years as a member of the Grand Lodge Judiciary Committee. In 1974 he was elected to a 4-year term on the Board of Grand Trustees, serving as Home and Pension Member, as well as Chairman. He presently is a member of the Grand Forum.

He is a member of the Palm Beach County, Florida State and American Bar Associations, the American Judicature Society, American Legion and the Sierra Club.

Brother Grafton and the former Patricia Anne Weiland were married in 1952, and have 3 children, Elizabeth 24, Mary 19, and John 16. They are members of St. Francis of Assisi Catholic Church in Riviera Beach, Florida.

Wherefore, North Palm Beach Lodge No. 2069 is extremely pleased to offer Brother Robert Grafton as a candidate for Grand Exalted Ruler, secure in the knowledge that his experience and leadership have fully prepared him to do an outstanding job in that office.

William K. Beyea, Exalted Ruler  
Robert J. Gee, Secretary



# NEWS OF THE LODGES

A benefit dinner-dance was held by **Deer Lodge, MT, Lodge** recently. The proceeds from the event helped defray the hospital expenses facing Brother and Mrs. Al Lowery, whose eldest son was injured in a motor bike accident. Many civic organizations, businesses, and individuals within the community joined the Elks in raising \$4,022.24.

More than 1,200 new citizens received their naturalization papers recently and were congratulated by their hosts, the Brothers of Bellflower, Downey, Huntington Park, Lakewood, Long Beach, Montebello, Norwalk, Paramount, San Pedro, and Whittier, CA, Lodges. The featured speakers for the event were Nathan Shapill, a naturalized citizen who survived a concentration camp, and Francis Dale, publisher of the Los Angeles *Herald Examiner*. Past GL Committeeman Bernard McCune, master of ceremonies, and Chm. Nick Capalia joined the California Brothers in presenting the new citizens with certificates of welcome and American flag pins.

A check for \$350 was contributed to Chenango Memorial Hospital by the Brothers of **Norwich, NY, Lodge** recently. Richard Riley, chief hospital administrator, thanked Chm. Frank Giltner, who presented the check on behalf of the lodge. The donation will be used to purchase equipment for the occupational therapy department.

Varsity basketball players from Stanford University judged a "Hoop Shoot" contest sponsored by **Palo Alto, CA, Lodge** recently. Chap. Joe Leitner (front, left) and "Hoop Shoot" Chm. Bill Donoghue (right) got some pointers from the experts (back, standing from left) Doug Marty, Jeff Ryan, Doug Barnes, and Steve Crandell.

Brothers recruiting Stanford University players to judge "Hoop Shoot" contest



A check for \$2,331, two color television sets, and 2,600 books and magazines were donated by **Millinocket, ME, Lodge** to the veterans hospital in Togus, ME. Additional books will be bought with the check. The 800 patients of the hospital thanked the Brothers for the gifts.

A class of new members was recently welcomed to **Flemington, NJ, Lodge**. The initiation took place in honor of PGER William Jernick, who, along with



Preparing hides for veterans

Preparing about 100 skins collected by **Woodland, CA, Lodge** was hard work for the Brothers. The salted hides are sent to a tannery in San Francisco before they are distributed to the VA hospitals. Brother Jim Trucker (above) was among those who rolled the skins gathered for the project.

Tribute was paid to long-time and dedicated members of Elkdom recently. **Rumford, ME, Lodge** honored their Brothers who have been members in good standing for 25 or more years. PDD George Skinner of **Kinston, NC, Lodge** received a state distinguished service award. Brother Skinner was instrumental in the institution of his lodge. **Decatur, IN, Lodge** honored Brother Charlie Weber, who has been an Elk for 66 years.

The proceeds from a white elephant sale held by **Chanute, KS, Lodge** were contributed to the Kansas Elks Training Center for the Handicapped, the state major project. June Campbell, director of development at the center, accepted the \$2,116 check and explained that the money will help pay for the expansion of the Training Center's wood-working facilities.

Three hundred permanent-type bingo cards were contributed by **Cobleskill, NY, Lodge** to the veterans hospital in Albany, NY, recently. Robert Boyd, hospital management analyst, thanked Elks' ladies Rose Armlin and Mary Calderone, ER John Calbo, Co-chm. Bogdon Demetrowitz, Brother Merrell Armlin, and Chm. Paul Calderone for delivering the gift.

Brothers from the New York Capitol District gathered at Saratoga Springs raceway for a fund-raising event recently. The proceeds from the affair augmented the district major projects fund.

## State Association Conventions

State	Date	Place
AK	5/17 thru 5/19	Kenai
CA & HI	5/16 thru 5/19	Anaheim
FL	5/17 thru 5/19	Kissimmee
ID	6/21 thru 6/23	Lewiston
IL	5/18 thru 5/20	Springfield
IN	6/7 thru 6/10	French Lick
IA	5/4 thru 5/6	Sioux City
KS	5/3 thru 5/6	Wichita
KY	5/24 thru 5/26	Princeton
LA	3/23 thru 3/25	Houma
MD, DE & DC	6/29 thru 7/1	Easton, MD
MA	6/8 thru 6/10	Bretton Woods, NH
MI	5/17 thru 5/20	Muskegon
MS	5/18 thru 5/20	Greenville
MO	4/6 thru 4/8	Cape Girardeau
NE	5/18 thru 5/20	Ogallala
NV	6/21 thru 6/23	Las Vegas
NH	6/1 thru 6/3	West Lebanon
NJ	6/7 thru 6/10	Wildwood
NM	4/19 thru 4/21	Albuquerque
NY	5/3 thru 5/6	Kiamesha Lake
NC	5/18 thru 5/19	Winston-Salem
OH	4/26 thru 4/29	Columbus
OK	4/27 thru 4/29	Oklahoma City
OR	5/3 thru 5/5	Klamath Falls
PA	6/7 thru 6/10	Philadelphia
RI	6/16 thru 6/17	Providence
SD	6/7 thru 6/9	Aberdeen
TN	3/29 thru 4/1	Gatlinburg
VA	6/8 thru 6/10	Lynchburg
WI	5/4 thru 5/6	Baraboo
WY	5/4 thru 5/6	Sheridan

SP James St. George, was on hand to congratulate one of the largest classes of Flemington Elks.





**NORWOOD, Massachusetts,** Lodge was the recent host to a group of Elks dignitaries who were present in honor of DDGER Peter Stupak (center). ER Wolfred Morganstern (second from left) joined (from left) VP James Consolmagno, GL Committeeman Arthur Kochakian, and PSP Donald Podgurski in welcoming Brother Stupak to his home lodge.



**A DINNER-DANCE** was sponsored by Harrisburg, PA, Brothers in a gesture of support of the Elks' commitment to veterans. A copy of the Elks' official proclamation written about their dedication to the country's veterans was displayed by (from left) Brother Clarence Baker, DDGER Fred Moeslein, and Americanism Chm. Herodotos Sophocleous (right) for Joshua Lock, county public defender. Mr. Lock was the guest speaker at the event.



**LEATHER** was presented to Oklahoma City VA Medical Center by the local lodge vets committee. Thanks were offered to the Brothers by Frank Caldwell (center), hospital director, and Leland Bowles (second from right), occupational therapy chief. Oklahoma City, OK, Elks (from left) S. R. Hutcheson, vets chairman, State Vets Co-chm. Wayne Moore, and ER Victor Isakson delivered the hides on behalf of the vets committee.



**A YOUTH** awards dinner held by Palm Springs, CA, Lodge paid tribute to students Rick Gill (second from left), Lorena Alonso (third), and Craig Murrell (fourth) for their accomplishments. Youth Chm. Willison Schaefer (left) and ER Charles Malin were on hand to offer the lodge Brothers' congratulations to the youngsters.



**ARTHUR MORGAN** (second from right) and Robert Gorham (second from left) were congratulated by DDGER F. Reginald Fuller (right) and ER Phillip Demers upon their election to life membership. The DDGER and the ER presented new cards to the two honored gentlemen in a ceremony at Concord, NH, Lodge during Brother Fuller's official visit.



At the Elks National Home in Bedford, VA, PGER Raymond Dobson (right) performed the holiday ritual of lighting the Christmas display by throwing the master switch. In mid-December, Brother Dobson was joined by Russell Otey, Bedford mayor, Grand Trustee Alex Harman, Virginia SP Robert Pannell, Maryland, Delaware and District of Columbia SP Marland Deen, DDGER Robert Stevens, South Carolina SP Arch Wallace, North Carolina SP William Goodwyn, Grand Chap. Rev. John Moeder, PGER John Walker, Grand Trustee A. Lewis Heisey, Grand Trustees Chm. H. Foster Sears, Pennsylvania SP Carlon O'Malley, and Illinois SP Fred Sheehan at the evening ceremony. By the end of the holidays, people in 18,050 vehicles had passed through the grounds of the National Home viewing the "festival of lights."

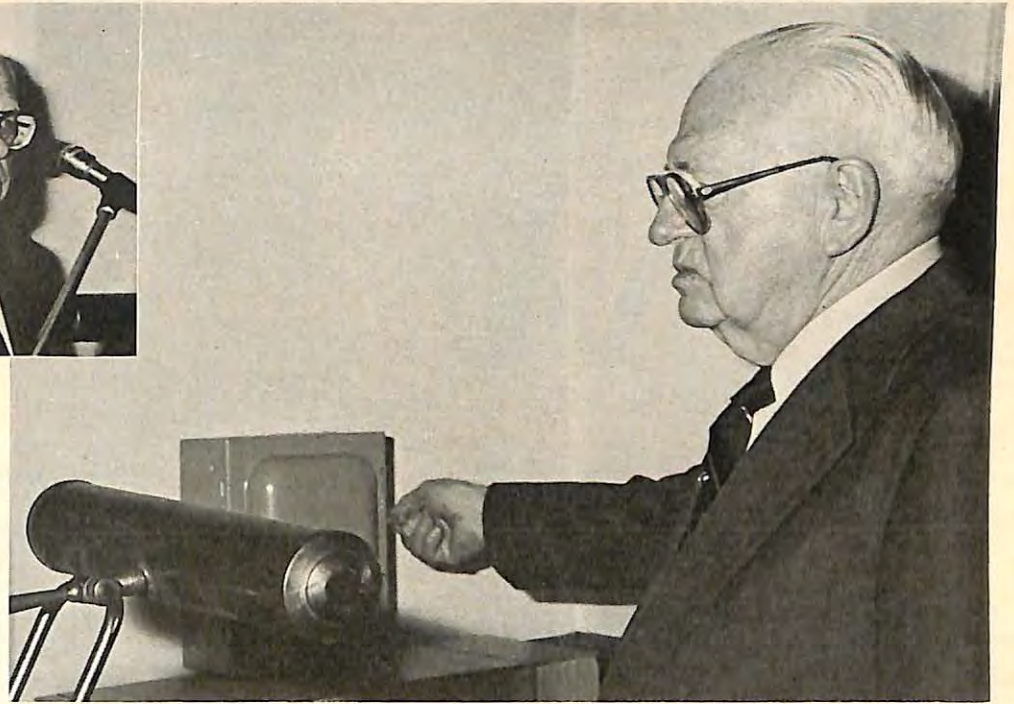

**A THREE-WHEELER** was purchased by the Brothers of Chula Vista, CA, Lodge as a replacement for the foot-powered three-wheeler stolen from Don McBride recently. The battery-powered cycle was presented to McBride, who has cerebral palsy, by ER W. L. Goodmanson, while the two owners of a local motorbike agency gave Don instructions on the use of his new vehicle. The lodge voted to use over \$850 from its local charity fund for the purchase.

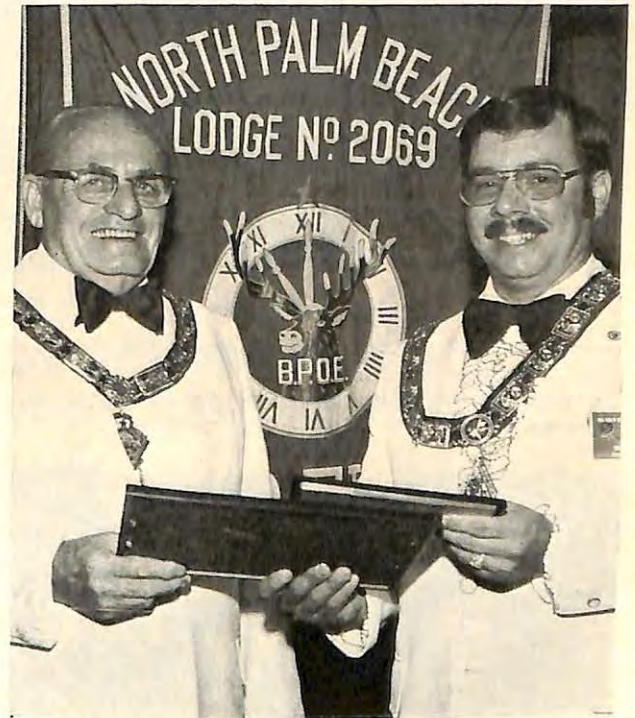

**DDGER EDGAR** Armstrong (left) received a National Foundation participating member's certificate and a Harry-Anna Hospital contributor's certificate. The presentation was made by ER William Beyea of North Palm Beach, FL, Lodge.



**IN CELEBRATION** of their 20th anniversary, the Elks of Port Jefferson, NY, Lodge shared their earnings with the state association's major project and the Jerry Lewis Muscular Dystrophy Telethon. During the lodge's annual charity ball, ER William Wohlars (second from left) presented a \$1,500 check for the major project, the treatment of cerebral palsy, to VP James Caroleo (second from right), while DDGER James Fountain (left) and PER Wallace Weaver observed.





**A FOURTH** \$1,000 donation to the National Foundation was made by PER Louis Ernster (second from right) of St. Paul, MN, Lodge recently. State Chm. Clarence Oster (second from left) accepted the check on behalf of the Foundation. PGER Francis Smith (right) and ER Winton Ramstrom observed the contribution and thanked Brother Ernster for his additional presentation of \$1,000 to the Elks State Youth Camp.

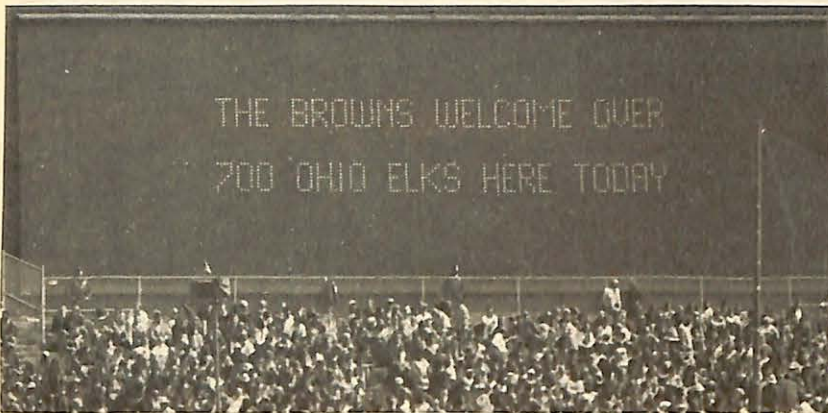

**THE FIRST** Ohio Elks Day at an NFL football game at the Cleveland Stadium was organized by Parma Lodge. The electronic scoreboard welcomed over 700 Elks from 21 Ohio lodges. Parma Brothers hosted post-game activities, which included the appearance of Brother Doug Dicken, Cleveland Browns offensive tackle. The event was so successful that plans are underway for an NFL Elks Day next year.



**A FIVE-FOOT** tall Mickey Mouse doll was donated to the United Hospital, a crippled children's hospital in Newark, NJ, by PER Anthony DiViccario (right) of Newark, NJ, Lodge recently. Presenting the gift during a party held at the hospital were PER and Chm. George Knott Jr. (second from left) and Co-chm. William Holland (left).



**AMBULANCE** squads from Colonie, NY, were honored by the local lodge at the annual George Bricker Memorial Ambulance Night. Among those in attendance were (seated, from left) Edward Potyrala, captain, Chm. Frank Taft, Lindsay Fahey, lieutenant, ER Michael Hoblock Jr., Ron Baker, captain, and (standing) Chm. Ron Olson, MC Al Litster, Mark Beattie, Art Fischer, and Charles Rappazzo, captain. Proceeds from the event were distributed to the town's ambulance squads by the Colonie Brothers.



**A BOY SCOUT** night was sponsored by Pearl River, NY, Lodge recently. Scoutmaster Edwin Ward (left) presented an Eagle Scout pin to Albert Sedlacek (second from left) and a Life Scout award to John Stedje. Mr. and Mrs. Sedlacek were present to congratulate the boys.



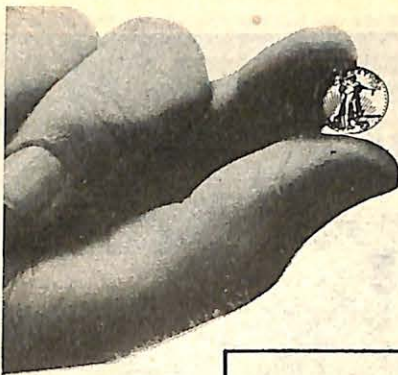

Actual Size!

## The World's First Miniature \$20 Gold Piece



**SOLID 14 KARAT GOLD - ONLY \$19.95**

*The Historic Providence Mint proudly announces the minting of the world's first miniature \$20 Gold Piece - in solid 14 karat gold*

You have a rare opportunity to possess the world's first miniature \$20.00 Gold Piece in solid 14 karat gold. This coin is an exquisite duplicate - minted in exactly the same manner as the first Saint-Gauden's \$20.00 Gold Piece struck at the U.S. Mint in 1907. Every detail - even the delicate sculpture of the tiny wing feathers is boldly defined. Carefully die struck in deep dimension, this truly magnificent coin highlights the unique Roman Numeral dates and the lustrous gold, mirror-like finish of Saint-Gauden's original. Each of these magnificent \$20.00 gold pieces is protectively housed in a plush collector's case. And every one is accompanied by an individually numbered Certificate of Authenticity and a 30 day money-back guarantee.

**AVAILABLE FOR A LIMITED TIME!**

This fabulous \$20.00 Gold Piece in solid 14 karat gold is available exclusively from the Historic Providence Mint. The price - for a limited time only - is \$19.95. This price is

guaranteed until April 30, 1979. However, due to the rising gold market, we urge you to act promptly. Send for your coin TODAY!

*Due to fluctuations of gold and silver prices on the world market, we reserve the right to withdraw this offer at any time. Current price is guaranteed only until April 30, 1979.*

### The Historic Providence Mint

Div. of The Harry Klitzner Co.  
Dept. EL-2, 222 Harrison Street, Providence, R.I. 02901

Please send:

..... G1 14 Kt. Miniature \$20 Gold Piece(s) at \$19.95 each  
plus 75¢ Postage and Handling.

Enclosed find check or M.O. for total amount due \$.....

Please charge:  Bankamericard/Visa  Mastercharge

No. .... Exp. Date .....

Signature .....

Send to .....

Address .....

City ..... State ..... Zip .....

RUSH my order. I enclose an extra \$1.00 for First Class Mail.



**Make \$800 An Hour and MORE Sparetime or Fulltime**

**BE YOUR OWN BOSS!**

**Sharpen Saws**

and other tools in Profitable Business of Your Own



SEND FOR EXCITING FACTS



Free Booklet Tells How

Hundreds of men now using the Foley plan successfully...  
... YOU Can Do It Too!

Find out TODAY how the proven Foley plan can quickly put you in a Money-Making business of your own. Work in your spare hours and weekends for extra income, or start a fulltime shop. Set the hours you want to work... keep the profits you earn. Age, education or minor handicaps are no barrier to success. No special skills, experience or huge investment needed — not a franchise. Start in basement or garage. No selling involved, no canvassing — keep 90% profit on every dollar you make. Plenty of business from handymen, carpenters, contractors and industry. **30-Day No-Risk Trial!** Send for complete facts and details without obligation. Our FREE Booklet tells how to start, how to grow, and how Foley will even finance you. **Act NOW!**

**Foley**

Just fill in coupon below. Mail to:  
1832 Foley Building  
Minneapolis, Minnesota 55418

Send for FREE Book! CLIP OUT AND MAIL TODAY

FOLEY Manufacturing Co. 1832 Foley Building  
Minneapolis, Minnesota 55418

Please send FREE Book about the opportunities in my own sharpening business. I understand there is No Obligation.

NAME \_\_\_\_\_  
ADDRESS \_\_\_\_\_  
CITY/STATE \_\_\_\_\_ ZIP \_\_\_\_\_

## Put Your Fund-Raising Program in the Winner's Circle

CINEMA RACES is a fascinating fund-raising formula used successfully by organizations throughout the U.S.A. The CINEMA RACES complete package includes: Authentic full-color-and-sound 16mm horserace films, programs, tickets, play money and easy-to-follow instructions. CINEMA RACES will make the most rewarding Game Night you've ever sponsored. Call or write for details.

**CINEMA RACES**  
Dept. E4

A General Instrument Company  
383 Hillen Rd. / Towson, Md. 21204  
301-321-8166



### ELKS RITUAL CLOCKS

No initiation or lodge ceremony is truly complete without our Emblem Model (as shown) or a Custom Ritual Clock. A Portable Model suitable for funeral services is also available. Optional features may be selected. Over 40 years of satisfied customers.

11th HOUR MFG. CO.  
1137 Dearborn St.  
Aurora, Ill. 60505  
312-851-7353



### HYDRAULIC JACK REPAIRS

Earn While You Learn In Your Spare Time

Trained and qualified mechanics needed NOW to service inoperative hydraulic jacks. BIG opportunity for ambitious men. We show you HOW — in your basement or garage to earn spare time cash in an expanding industry. Don't wait, ACT NOW! Get the facts.

Write for folder E3 and free bonus offer

Hydraulic Jack Repair Manual Co., Inc.  
P. O. BOX 3 • STATEN ISLAND, N. Y. 10314



# IT'S YOUR BUSINESS

by John C. Behrens



## KEOGH PLAN: A SOUND DEDUCTIBLE

One of the things that always bothers me about this time of year is finding out about deductions I could have taken... if I had remembered or known about them. It never fails. Either I didn't declare at the right time or I overlooked it when my accountant and I put the figures together.

The Keogh Plan is a good example.

While it's one of the most practical steps self-employed proprietors and professionals in the \$10,000 to \$50,000 income bracket can take, accountants tell me, a number of businessmen apparently overlook it.

The much-publicized Keogh Act, which Congress has tuned and retuned since its inception in the early 1960s, is a business retirement program that can give you the satisfaction of knowing that a portion of those hard-earned profits won't be absorbed by taxes... at least for the present.

Accountants, architects, some doctors and dentists, owners and co-owners of unincorporated businesses and even those who work at one place and moonlight elsewhere among others, can be eligible to participate. The latitude of the Keogh gives those with irregular kinds of income—for example, an author who publishes a book—an opportunity to shelter up to \$7500 or 15 percent of income in one year without guaranteeing similar amounts in the years that follow.

The regulations and the "legal boilerplate," some contend, have made conventional Keogh contracts at banks, insurance companies and brokerages more complicated. The difficulty, most agree, is trying to retain flexibility and understand the restrictions found in some custodian agreements. The dilemma is that many seeking such plans know little about the mechanics, and those who administer them aren't always up-to-date on the changes and interpretations that govern such accounts.

For example, there is disagreement over the withdrawal procedures described in many Keogh accounts. Some interpret the IRS guidelines to mean that the funds can be withdrawn between the age of 59½ and 70½, no earlier and no later without penalty. Others interpret the guidelines more narrowly.

Another problem is how the account can be used. Accountants and bankers insist it cannot be used as collateral. Yet

the agreements don't clarify the issue.

Generally, everyone agrees about the basic benefits, though. One: the self-employed person gets a deduction for amounts he pays into such a plan. The deduction may not exceed \$7500 or 15 percent of his self-employed income, whichever is less. Two: earnings on retirement fund investments are not taxable until the funds are distributed, usually at retirement or death. Three: lump sum distributions of deducted contributions and investment earnings qualify for reduced taxation in the form of tax averaging.

It's possible for a self-employed person to establish his own program but it's more likely he will join some form of existing agreement, say those familiar with Keoghs. A practitioner, for example, might find it much easier and more beneficial to join a trade or professional association plan. At the same time, a business owner might want to arrange a bank, investment brokerage or insurance company program, or he may want to invest in US Treasury Retirement bonds.

The advantage of dealing with a bank, a CPA explains, is the interest the money earns without risk. The banks, he points out, are the safest place to merely put money aside and not really be involved until retirement. On the other hand, such arrangements could be a disadvantage to others. Such plans have a fixed rate for the money invested and the agreement may stipulate tight controls. For example, a bank may determine the manner and circumstances in which the fund can be withdrawn, and it may also declare itself owner of the account as custodian.

An investment house can give its client more growth potential. It can manage investments in blue chip stocks, dividends and capital appreciation and take care of the responsibilities the proprietor simply doesn't have time to handle. The more common arrangement is for a brokerage to set up a custodial account with the bank and instead of putting funds in savings, the bank buys bonds and/or stocks for the plan through the brokerage.

Yet there are disadvantages here, too. Stocks go down as well as up in today's fluid marketplace and such arrangements must be entered with the knowledge of such risks. In addition, commissions can be high.



# Compare our prices on HIGH POTENCY VITAMINS



AND SUPPLEMENTS FROM  
**NUTRITION HEADQUARTERS**  
All prices POSTPAID! Satisfaction guaranteed or money back.

25 MCG.  
**SELENIUM**  
TABLETS  
New Low Price  
100 TABLETS **1.69**  
500 for 7.50  
1,000 for 12.49

10 MG.  
**ZINC**  
TABLETS  
100 TABLETS **49¢**  
1000 for 4.45

Vitamin B6  
50 MG Tablets  
100 TABLETS **95¢**  
500 for 4.25

**KELP**  
Tablets (Iodine)  
100 TABLETS **39¢**  
1000 for 2.49

**VITAMINS FOR HAIR CARE**  
Same Formula Others sold for 9.95  
50 DAY SUPPLY **\$3.95**

**GARLIC & PARSLEY**  
TABLETS  
100 TABLETS **75¢**  
500 for 3.25

**BONE MEAL**  
TABLETS  
100 TABLETS **79¢**  
500 for 2.49  
1000 for 4.45

500 MG.  
**ASCORBIC ACID**  
VITAMIN C  
100 TABLETS **95¢**  
500 for 4.49

Dessicated  
**LIVER**  
TABLETS  
100 TABLETS **79¢**  
500 for 3.49

**DOLOMITE**  
Calcium Rich  
100 TABLETS **49¢**  
500 for 1.85

"Formula T-M"  
Therapeutic Multi-Vitamins with Minerals  
100 TABLETS **\$1.85**  
500 for 8.99

**HERBAL LAXATIVE**  
100 TABLETS **95¢**  
500 for 4.35

**BIG 4**  
KELP, VIT. B6, LECITHIN, CIDER VINEGAR  
100 TABLETS **98¢**  
500 for 3.88  
1000 for 6.88

19 GRAIN  
**LECITHIN CAPSULES**  
(1,200 mg.)  
100 CAPSULES **1.59**  
300 for 4.39

500 MG  
**BRAN**  
TABLETS  
Easy way to get this important wheat fiber.  
100 TABLETS **85¢**  
500 for 3.49

500 MG.  
**TIME RELEASE VITAMIN C**  
CAPSULES  
100 CAPSULES **2.98**

**PAPAYA PAPAINE**  
(Digestant)  
100 TABLETS **75¢**  
500 for 3.25

**HERBAL CALMATIVE**  
Helps relax tensions for a good night's sleep  
100 **\$3.00**  
250 **\$6.50**  
500 **\$12.50**

**VITAMINS A & D**  
(5,000 A; 400 D)  
100 TABLETS **49¢**  
1000 for 3.50

ONE GRAM  
**DIET PROTEIN**  
TABLETS  
Each contains 1 gram of protein.  
240 TABLETS **4.95**  
No carbohydrates  
No fats

**BREWERS YEAST**  
TABLETS  
250 TABLETS **65¢**  
1000 for 1.95

**LECITHIN POWDER**  
Dissolves Easily  
8 oz. **1.49**

100 MG.  
**GINSENG**  
TABLET  
50 TABLETS **99¢**  
250 for 3.95

250 MG.  
**SUPER GINSENG**  
TABLET  
100 TABLETS **2.98**  
500 for 12.95

**ALFALFA**  
Tablets  
100 TABLETS **49¢**  
500 for 1.95

Super Potency  
500 MCG.  
**VITAMIN B12**  
100 TABLETS **1.19**  
500 for 4.25

**VITAMINS A & D**  
(5,000 A; 400 D)  
100 TABLETS **49¢**  
1000 for 3.50

**ACIDOPHILUS CAPSULES**  
(Our Price)  
100 CAPSULES **2.50**  
250 for 4.95

**BY MAIL POSTPAID**

## VITAMINE

400 UNIT CAPSULES  
 50 DAY SUPPLY **88¢**

100 FOR **\$1.49**     500 FOR **\$7.25**     1000 FOR **\$13.98**

Limit: One of Any Size to A Family

Mail Coupon with remittance to  
**NUTRITION HEADQUARTERS**  
104 West Jackson, N1885  
Carbondale, Ill. 62901

© 1978, Nutrition Hdas.

500 mg.  
**VITAMIN C**  
with Rose Hips  
100 TABLETS **1.69**  
500 for 7.95  
1,000 for 14.75

**MULTI-MINERALS 9 VITAL MINERALS**  
100 TABLETS **98¢**  
500 for 4.50

**CHOLINE**  
250 MG. TABLETS  
100 TABLETS **1.65**  
500 for 6.95

**HI-POTENCY STRESS FORMULA**  
(Same formula as PLUS 72)  
100 TABLETS **1.95**  
250 for 3.89

**DOLOMITE & BONE MEAL**  
100 TABLETS **69¢**  
500 for 2.65

**ARTHRITIS RHEUMATISM PAIN? TRY "RELEEZE" FOR**  
Quick temporary relief of Arthritis, Rheumatism, Bursitis pain. Apply directly to the pain area. Many users say "there is nothing finer."  
2 oz. bottle **4.95**    2 bottles **9.00**

500 MG.  
**BEE POLLEN**  
TABLETS  
100 TABLETS **2.49**  
500 for 9.85

**GARLIC OIL CAPSULES**  
100 CAPSULES **79¢**  
500 for 3.75

595 MG.  
**Potassium GLUCONATE**  
100 TABLETS **1.25**  
500 TABLETS **5.00**  
1,000 TABLETS **9.50**

**WE STOCK MANY HERBS**  
Include this coupon with order for complete price list.

**HERBAL DIURETIC**  
TABLETS  
HELPS REDUCE EXCESS BODY FLUID AND THE WEIGHT THAT GOES WITH IT.  
If your clothes are too tight from time to time even though you haven't changed your eating habits, you may be retaining excess body fluid. This condition affects your whole body right down to your ankles.  
Feeling bloated and puffy can be the result of water retention. Also, extra weight is another factor. It is a fact that a quart of water weighs over two pounds.  
Safe, mild HERBAL DIURETIC TABLETS help eliminate excess water in your body, so you can feel slimmer and more comfortable.  
100 Tabs. **1.75** 500 Tabs. **6.50**

**WE HAVE FRUCTOSE**

<input type="checkbox"/> 2 Gram Tablets (8 calories per tablet) 225 Tablets	<b>4.49</b>	<input type="checkbox"/> 3 Gram Packets Box of 50	<b>1.98</b>
<input type="checkbox"/> SPECIAL 5 Bottles	<b>19.75</b>	<input type="checkbox"/> 3 Boxes	<b>5.75</b>

ORDER BY MAIL AND SAVE N1885

**PROTEIN DIET POWDER**  
16 oz CONTAINS 416 GRAMS OF PROTEIN  
lb. **3.98**

**ORGANIC IRON Supreme**  
100 TABLETS **1.49**  
500 for 4.95

**VITAMIN E Beauty Cream**  
1 oz. Jar **1.00**

Our "TOP-B" B-COMPLEX "50"  
Famous Formula at a Sensational Low Price!  
Every Capsule Contains 50 mg. B1, B2, B6, Niacinamide, Pantoic Acid, Choline, Inositol; 50 mcg. B12, Biotin; 50 mg. Paba; 100 mcg. Folic Acid.  
50 Capsules **2.49** 100 Capsules **3.98**  
250 for 9.49

**GRAPEFRUIT DIET PILL**  
Contains one of the strongest diet aids available without prescription. Includes modern, effective diet plan that lets you enjoy 3 delicious meals and snacks everyday as you lose weight.  
90 for **\$2.98**  
500 for 9.85

"SPECIAL C-500"  
500 mg. Vit. C Plus Rose Hips, 100 mg. Bioflavonoids, 50 mg. Rutin, 25 mg. Hesperidin  
100 TABLETS **1.89**  
500 for 8.49

**Money Saving MAIL ORDER BLANK** **RUSH Your Order Now to:** THE BEST TIME TO SAVE IS NOW!  
**NUTRITION HEADQUARTERS**  
104 West Jackson St.— N1885  
Carbondale, Ill. 62901

List items you wish here:

QUAN-TITY	SIZE	NAME OF PRODUCT	TOTAL PRICE

**SATISFACTION GUARANTEED** **WE PAY ALL POSTAGE** **TOTAL—amount enclosed**

PRINT NAME \_\_\_\_\_  
ADDRESS \_\_\_\_\_  
CITY \_\_\_\_\_ STATE \_\_\_\_\_ ZIP \_\_\_\_\_



WITHIN 2 OR 3 YEARS OF RETIREMENT?



ENJOY an Arizona Vacation  
in a lovely apartment in

**Sun City West**

STANDARD OF THE WORLD IN RESORT-RETIREMENT LIVING

A FABULOUS RESORT VACATION \$150\*  
FOR ONE OR TWO PEOPLE JUST

Golf, tennis, swimming and special parties are just a few of the things you'll be invited to enjoy. Plus you'll stay in a beautiful air conditioned apartment with a completely equipped kitchen, color TV, attached carport and private patio. Just 15 miles from exciting Phoenix. Easy drive to the Grand Canyon, Mexico or Las Vegas.

\*INTRODUCTORY RATE:

For 1 week: Jan. 1, 1979-May 31, 1979

For 2 weeks: June 1, 1979-Oct. 16, 1979

Rates subject to change without notice

MAIL THIS COUPON TODAY!

DEL E. WEBB DEVELOPMENT CO. DEPT. EM-39  
P.O. BOX 1725, SUN CITY, ARIZONA 85372

Send all details on the \$150 Vacation Special plus full-color brochure to:

Name \_\_\_\_\_

Address \_\_\_\_\_

City \_\_\_\_\_ State \_\_\_\_\_ Zip \_\_\_\_\_

\*One guest to be 50 or over, none under 18. Reservations limited to available dates. Return visit Rate: \$200  
13601 Meeker Blvd., Sun City West, AZ  
Equal Housing Opportunity Employer  
Sun City West is not a lot sales development

# BINGO

FOR PERMANENT  
FUND RAISING

Easy way to raise money for your Organization because everyone has fun playing BINGO! Thousands of Organizations are making up to \$500.00 per week using "BINGO KING" supplies and FREE Idea Bulletins. Write for FREE catalog and details on raising money for your Organization.

PLEASE GIVE NAME OF ORGANIZATION.

'BINGO KING'  
DEPT. EL-79, BOX 2499, LITTLETON, COLO. 80161

World's largest  
suppliers  
of gun parts

NEW  
for '79<sup>8th</sup>  
EDITION  
CATALOG #8 ONLY \$2.95  
(Foreign cost \$3.95)

this catalog "THE LARGEST EVER" - page after page of many difficult and hard to find new and obsolete parts, stocks and barrels.



**NUMRICH ARMS  
CORPORATION**

WEST HURLEY, N.Y. 12491

TELEPHONE: AREA CODE 914 679-2417 Telex #145 331

## YOU CAN QUIT SMOKING

QUICK! NO CRAVING! EASY!

You can quit smoking in the privacy of your home or office. No Pills. No Gadgets. No Clinics. No Lectures. No Withdrawal Symptoms. Money back guarantee.

Sleep better, breathe easier, save money and live longer. Let us help you become free of the smoking habit. Write now for information on "You Can Quit Smoking".

TRYCO PUBLICATIONS; Dept. ELK 101;  
7001 35th Ave., N.E.; Salem, Oregon 97303

# MEDICINE AND YOU

by Larry Holden

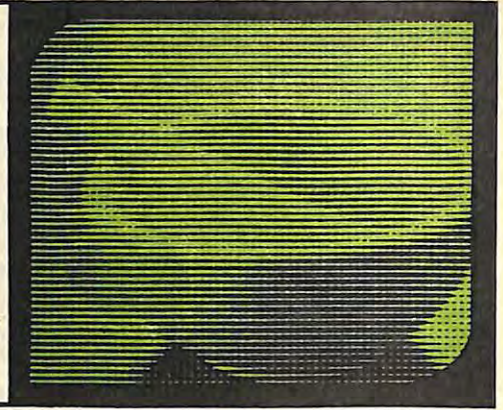

## DIABETES: THE OVERLOOKED KILLER

Diabetes is third on the list of killer diseases, outranked only by cardiovascular diseases and cancer. Yet when a recent Gallup poll asked Americans which diseases they feared most, diabetes did not even make the top ten.

Diabetes is a slow and quiet killer. It infrequently makes the headlines although *uncontrolled diabetes kills*.

In a study made by the National Commission on Diabetes, some startling realities were made which clearly document a health problem of the greatest magnitude. The study revealed:

⊙ Between 1965 and 1973 the prevalence of diabetes increased by more than 50 percent in the United States.

⊙ In 1974 alone more than 600,000 new cases of diabetes were diagnosed and the rate of diabetes appears to be increasing by six percent a year.

⊙ Diabetics are 5 times more prone to blindness than non-diabetics, 17 times more prone to kidney disease, five times more prone to gangrene—often leading to amputation—and twice as prone to heart disease. The life expectancy among people with diabetes is approximately one third less than that of the general population.

⊙ 38,000 deaths in the United States in 1974 were directly linked to diabetes. Further evidence indicates that diabetes and its complications are responsible for more than 300,000 deaths annually, putting it into the third ranking category on the list of killer diseases.

⊙ Efforts to cope with diabetes have failed to prevent the disease from increasing. Few substantial improvements in therapy have occurred since the discovery of insulin more than 50 years ago. Despite considerable research in diabetes and metabolism, the biochemical basis of the disease remains unknown.

⊙ Women are 50 percent more likely than men to have diabetes, non-whites are one fifth more likely than whites to have it, and poor persons (income less than \$5,000 per year) are three times as likely as middle-income and wealthy individuals to have the disorder.

⊙ During pregnancy, diabetes increases the chances of premature delivery and death of the baby.

⊙ Diabetes is the third major chronic ailment of children, as well as the most common endocrine disorder among young people.

⊙ About half of the children with diabetes now living will die of kidney failure within an average of 25 years after the diagnosis of diabetes. The National Commission on Diabetes estimates there are currently 86,000 children facing the prospect of blindness and death from kidney failure prior to the age of 40.

Added to the physical problems of the diabetic, the Commission declares, are the psychological and economic effects on the diabetic patient and his family. Of the diabetic population, 14 percent are bedridden for an average of one and one-half months per year.

Diabetes can develop at any age. The highest incidence occurs between the ages of 40 and 60, whereas the percentage of cases in infants and children is comparatively small. Diabetes can develop after the age of 70; however, the incidence is much lower among the elderly than in the middle-aged group.

Diabetes is caused by the body being unable to use food properly. It is a hereditary-related disease caused by an insufficient supply of insulin in the body.

Insulin, a hormone produced by a gland in the abdomen called the pancreas, is released into the bloodstream to regulate the rate at which the body cells use and store sugar. This sugar, which is derived from the food we eat, supplies the energy that the body cells need to sustain life and keep the body functioning in a normal manner.

Because the symptoms of diabetes are not always obvious, it's sometimes called the "hidden disease." Many people, especially in the older age groups, may develop diabetes but have no visible symptoms to warn them. They may just not feel well. In such persons the disease is detected through a blood sugar test. Some signs to watch for and to report to your physician include: undue fatigue, unusually frequent urination, rapid weight loss, vaginal itching, sores that don't heal and headaches accompanied by dizziness and nausea.

Other classical symptoms of diabetes may also be blurring eyesight and skin disorders such as boils, carbuncles, and infections. Despite these obvious signs many people either are unaware of them or simply ignore them. As a result, for every four known cases of diabetes, about three are undetected and untreated.



# THEY FLEW THE UNFRIENDLY SKIES!

Own These Full-Color, Collector's Lithographic Reproductions of

## 4 ACES

WWI'S Greatest Flying Aces

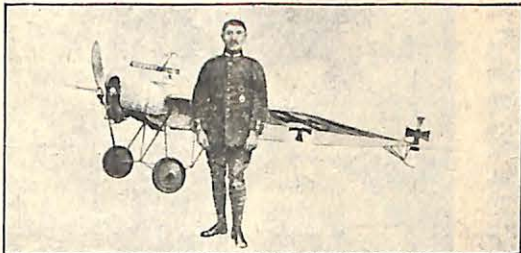

Max Immelman  
Germany's first WWI ace

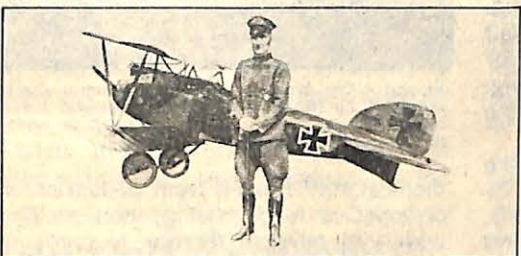

The Immortal "Red Baron" von Richtofen  
Top WWI Ace, with 80 victories



Georges Guynemer  
Youngest and Greatest French War Hero

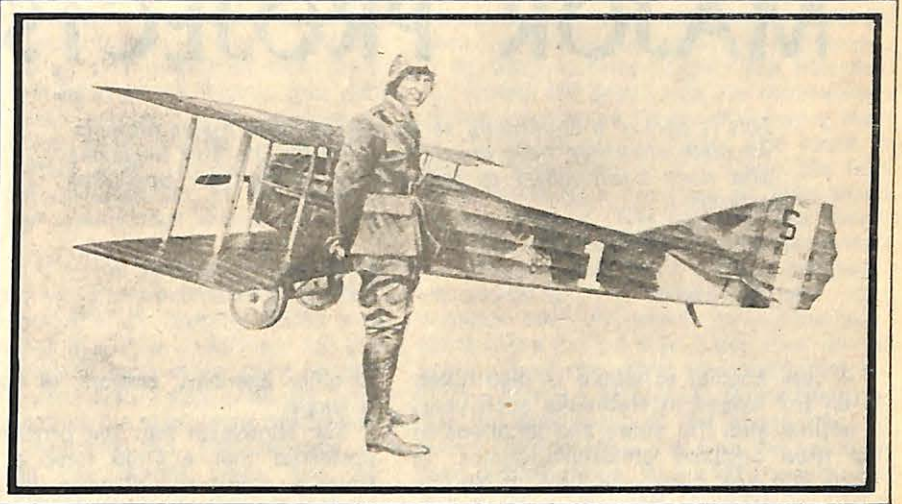

Captain Eddie Rickenbacker with his Spad 13  
His record was never equalled

## 4 GALLANT YOUNG MEN & THEIR FLYING MACHINES

They dared greatly, they achieved much with little and they took the first bold steps that led to today's modern aerial warfare. Fueled as much by courage as anything else, their flimsy but ferocious craft streaked like angry wasps over No Man's Land — and more than 60 years later they are still heroes, remembered with respect and admiration.

The original works of art from which these prints are reproduced are part of a private collection not available for viewing by the general public. But now, you can own your own copies, so skillfully reproduced they possess the same nostalgic quality as the originals.

Each print is reproduced with complete fidelity on luxurious museum-quality, 100% rag paper for the permanent enjoyment of you, your family and friends. Each measures 12" x 17" overall, with a 9" x 13½" image area. Carefully researched and painted in meticulous detail by Dennis Markus, they will enhance any room or office. Each print is suitable for framing.

### ASSEMBLED FOR IMMEDIATE ACCESSIBILITY IN THIS HANDSOME PORTFOLIO

Your reproductions of World War I Aces will come to you in a tastefully-designed, permanent and durable portfolio, elegant in appearance and strong enough to keep your prints in mint condition as long as you own them. Shipped in special package to insure arrival in perfect condition.



### MONEY-BACK GUARANTEE

If for any reason you are not completely pleased with your set of 4-ACES Prints, you may return them within 30 days and receive a full refund.

Don Jimmies  
THOMPSON AND COMPANY

TO ORDER YOUR 4 ACES, JUST FILL OUT, CUT OUT AND MAIL THIS COUPON

### THOMPSON & COMPANY

200 North Edison, Dept. A264  
Box 1839, Tampa, FL 33601

A264

Under your money-back guarantee, send me the four lithographic prints of WWI aces and their fighter planes, nestled in an elegant presentation portfolio, for only \$16.95.

- I enclose \$ \_\_\_\_\_ (Florida residents add 4% sales tax.)  
 Charge to my:  
 Visa/BankAmericard  
 Master Charge  
 American Express

Credit Card No. (Print All Digits) \_\_\_\_\_

Master Charge Also Enter Exp. Date  
4 Digits Below Your Acct. No. \_\_\_\_\_

name \_\_\_\_\_

street \_\_\_\_\_

city state \_\_\_\_\_

zip \_\_\_\_\_



Shipping & Insurance  
Add 50¢ for all shipments in 48 Continental United States  
Add \$1 for APO, FPO & shipments outside 48 Continental United States

© 1979, Thompson Cigar Co.

CREDIT CARD HOLDERS SPEED DELIVERY BY CALLING **TOLL-FREE: 800-237-2559**



# MAJOR PROJECTS

*This is part of a continuing series on the state major projects. All state chairmen have been contacted by The Elks Magazine and have been asked to forward information for upcoming articles.*

A very special schedule is distributed to all the lodges in **Nebraska** each year. It enumerates the dates and locations of the area crippled children's clinics. In 1978, the first clinic was held at Norfolk Lodge on January 28 and provided general diagnostic screening and service for those with cerebral palsy, heart conditions, and asthma. Between January and December 9, 23 clinics were held at various locations throughout the state. The August Schneider Crippled Children Commission, Nebraska Elks Association's major project, joined with the Services for Crippled Children, a program administered by the State Department of Public Welfare, to conduct those clinics along with three other types of services for afflicted children.

As partners in caring for Nebraska's crippled children, SCC (Services for Crippled Children) and the Elks deal with a wide range of problems, which includes orthopedic conditions, cerebral palsy, oral handicaps (cleft lip and palate), heart disease, systic fibrosis, eye conditions amenable to surgery, neurological defects, hearing loss, and neoplasms (leukemia and lymphoma). In the consideration of these conditions the SCC emphasizes that children ought to have the chance to overcome or mitigate the difficulty of being handicapped. Embraced by the program is the belief that rehabilitation of a handicapped child contributes to the richness of the future for the state and for the child.

Complementing the expanse of afflictions dealt with by the SCC is a gamut of services available to children. In addition to the area clinics, there are permanent clinics in Lincoln and Omaha. Doctors in Scottsbluff, North Platte, Kearney, Norfolk, Hastings, Grand Island, and Lincoln participate in the program on a contract basis. Treatment and follow-up care are provided by the doctors involved in the program. Paramedical services, including physical, occupational, and speech therapy and the provision of drugs and appliances (braces, hearing aids), inpatient and outpatient hospital services, mental health and social services, home health care, transportation assistance, and nutritional guidance are all part of the major project program. In the event that a child's needs cannot be met through the program, every effort to refer a child

to other agencies, doctors, or therapists is made.

For admission into the program, it is preferred that a child have a referral from a physician, because information provided by a doctor is usually more accurate and complete than that given by a parent or social service. Children are accepted into the program on the basis of certain medical conditions the family cannot combat due to their financial situation. All children, however, can receive the free diagnostic screening. A first visit to a clinic or program staff member may be for consultation only, for treatment, or for a diagnostic screening. Emergency situations are handled by the SCC branch in Lincoln.

At one time the major concern of the Nebraska Brothers did not include involvement in area clinics, but only, around the turn of the century, support of an orthopedic hospital in Lincoln. It was in 1929 that the Brothers recognized the need for area clinics. With the passage of the Federal Social Security Act in 1935 came official governmental concern for crippled children. In October of that year the Nebraska state legislature passed the State Assistance Act, which created SCC under the state's Child Welfare Bureau.

The availability of federal and state funds for the care of crippled children met the Nebraska Elks' goal "to interest government in improving and expanding services for crippled children." Working together, the SCC and the Elks continued to help handicapped children, and in 1954 a written document solidifying their partnership in this endeavor was composed.

The Brothers' involvement in the major project takes different forms. Monetarily, they allotted \$57,655.42 for 1978-1979. The workings of an exemplary area clinic reveal the Brothers' and Elks' ladies' direct involvement with the program.

An area clinic was held in Norfolk on July 29, 1978, at the Elks lodge. Among those scheduled for the services offered there were 15 patients for the cerebral palsy clinic, 25 for the heart clinic, and one for the screening. Although prior appointments were suggested, they were not mandatory. Twenty-one doctors and medical professionals arrived at the lodge to run the clinic. The specialties of the



*Fitting a leg brace is one of the many services provided by the Nebraska major project; helping those in need who can be helped is one of the project's precepts.*

medical staff ranged from pediatrics and orthopedics to psychology and sociology and from physical therapy to cardiology and EKG technology.

The Elks' ladies worked on the voluntary, non-medical staff serving the clinic, which was open at 7:30 AM and included a free lunch for the children and their families. The state chairman and his wife attend all the area clinics and transport the equipment necessary to set up and conduct the examinations and treatment services.

The effectiveness of clinics like the one in Norfolk is evidenced by the success of ensuing therapy and medical programs. In March of 1978 a screening, hearing, cerebral palsy, and heart clinic was held at Kearney Lodge. One of the patients, 8-year-old Kellie, was examined by four heart specialists and a pediatrician. She was admitted to the University Hospital in Omaha the following week and underwent tests and a heart catheterization. The results of the tests indicated the need for intestinal surgery, which was a total success. Heart surgery was scheduled for June and complete health was within reach for Kellie.

Behind the services offered at the various clinics and through the other branches of medical attention there must be a continuous source of funds. The Nebraskan Brothers join the SCC in providing the financial backing. Of the per capita dues for membership, 50¢ goes to the major project fund. Interest on invested stocks and bonds, money raised by the annual Exalted Rulers' March,



memorials, and miscellaneous donations are sources of income for the support of the project.

It is more than funding that keeps the Nebraska major project running. The dedication of the administration and staff in all phases of the program is fundamental to the working of the project. The spirit of confidence that conditions which may prevent a child from realizing his or her potential can be overcome increases the strength of that dedication.

The history of the Ohio Elks major project began with the establishment of a cerebral palsy treatment center in 1951. Since then, the program has been altered several times. The Elks CP Training Board, as administrator of the project, ensures that those changes in the CP program do not interfere with its growth and that it continues to serve people as effectively as possible.

The original treatment center was fully equipped and staffed by professional therapists. All expenses were paid by the Ohio Brothers. By 1954, though, they began to think that more people would benefit from a mobile unit division which could reach areas where there were no treatment facilities. After it had received several years of support from the Elks, the treatment center was transferred to a county branch of United Cerebral Palsy.

When it began operation, the mobile therapy unit was well received by the

people and families it served. In fact, the Elks had not anticipated the extent of the need for such a therapy program, but they responded to that need with the addition of a second unit. The new unit supplied the services of both an occupational therapist and a physical therapist. Children who benefitted from therapy were treated in the mobile unit program, which worked from designated care centers. Elks' lodges, churches, and hospitals were among the institutions that volunteered to be centers where the youngsters could visit the units.

Until 1975, the mobile unit program continued with the backing of Ohio Elks. At that time the CP Training Board met and decided that they could best aid the cerebral palsied by pointing their project in a new direction. Established CP centers throughout the state were requesting the Elks' financial aid. The expense of conducting the mobile units had increased greatly; traveling therapists were less necessary and less available.

The Board moved to help fund established treatment centers. Seventeen of the centers received \$91,600 in 1977 from the Elks. With the CP Board acting as the governing body, the money raised from member donations, the National Foundation, and events sponsored by the Elks' ladies and Brothers is distributed to the centers across the state. The only specific donation requested of the Elks is an annual one dollar per member.

Among the projects which receive Elks funding is a Family Living Institute

Program. Conducted by the Ohio Easter Seal Society, the program has been deemed a success. Last year about 33 adults and 37 children attended the Institute, where they were able to discuss, examine, and learn about their interactions as families affected by handicaps.

An administrator of the Ohio Elks major project CP Board saw the significance of the program in terms of a young man he met at Elks conventions. The youth, a victim of cerebral palsy, made his first appearance at a conclave of Elks when he was a child. The boy and the therapist who accompanied him demonstrated the effectiveness of his therapy program. He appeared at a number of Elks conventions over the years, each time presenting the Brothers an illustration of his accomplishments after treatment that included physical and occupational therapy. The thoughtfulness of the young boy, in taking time to show the Elks the value of their contributions, is a vivid memory for that administrator and, probably, for many other Elks who met him. A college graduate, married and employed now, the young man no longer needs the therapy program which had an effect on his life.

The Ohio Elks hope that through their funding, they will guarantee effective programs for other people with cerebral palsy. The accomplishments of people with cerebral palsy who have received treatment is a dividend for the Elks. Throughout the history of their project, they have continued to search for the best way they can serve the people of their state. ■

## You and Retirement

(Continued from page 10)

And your facial appearance will not change.

Immediate dentures are not advisable for every patient. Even where they can be used, moreover, they have some disadvantages. More office visits will probably be required in the long run, as the shape of your mouth changes and the dentures must be adjusted. Sometimes, in fact, tissues change so much that new dentures must be made after a few months. In the areas where the last remaining teeth will be removed, immediate dentures will not always fit quite as accurately as conventional dentures made at a later date, after the gums have healed and hardened.

"Modular" dentures, like conventional ones and unlike the immediate variety, are fitted after all teeth are out and the gums have healed. They are less expensive than conventional dentures, however, because no attempt is made to replicate the irregularities or shadings of the natural teeth. Instead, a choice is made among a limited number of sizes and shades.

Learning to live with dentures, wherever you get them and whatever type they are, is not easy. You must learn to eat and speak with an unfamiliar object in your mouth, and this takes both time and patience. The American Dental Asso-

ciation offers some pertinent advice:

- ⊙ Don't expect dentures to make you look 20 years younger. Don't expect them to function as well as your natural teeth.
- ⊙ Continue to visit your dentist regularly, so that general oral health can be checked and dentures adjusted as necessary. Continuous changes in the mouth can alter the fit of dentures, and ill-fitting dentures can cause serious problems.
- ⊙ Do not attempt to adjust or repair

your denture yourself. If you relines them, you can make them too tight, putting pressure on the supporting ridge. If you repair them, you may unwittingly use glue containing solvents dangerous to both the denture and your mouth. You are more than likely to align the broken parts incorrectly. Breakage while eating, furthermore, is often a sign of change in fit, and the entire denture may need to be adjusted or remade. ■

### NEW FOR THE ELKS MAN

These beautifully hand-crafted pieces of Elk styled jewelry will make a handsome gift, or buy it for yourself, you deserve it. All pieces are unconditionally guaranteed against breakage.

Watch band, belt buckle and bolo tie are available in silver plate or gold plate; your choice at one low price.

Watch band—\$19.95. Belt buckle—\$16.95. Bolo tie—\$12.95.

Price includes shipping and handling. Please allow up to 3 weeks delivery time from date order is placed.

When ordering, be sure to specify gold or silver. To order thru:

■ BankAmericard ■ VISA ■ Master Charge (check one)

Fill in card numbers & expiration date below.      date

--	--	--	--	--	--	--	--	--	--

Send all orders to J&L Enterprises, P.O. Box 486, Montebello, CA 90640, (213) 724-6407.

### FIND BURIED TREASURE

Find buried gold, silver, coins, treasures with powerful new electronic detector. Ultra sensitive. Penetrates deep into earth. Works through mud, beach sand, rock, wood, etc. Signals when object is detected.



Write for Free Catalog, treasure hunting tips and unusual souvenir coin.

**RELCO** Dept. DD29, Box 10839, Houston, Tex. 77018



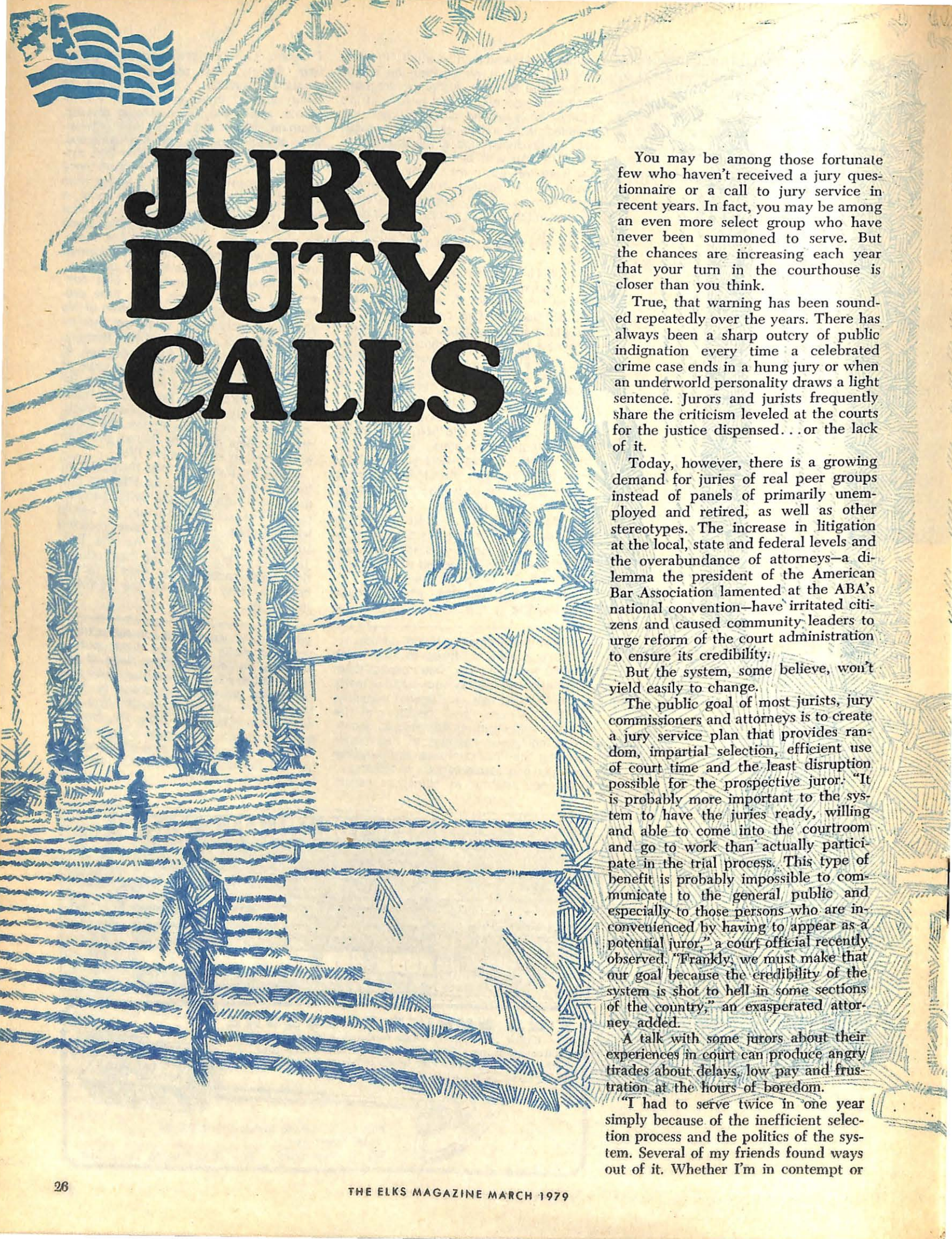

# JURY DUTY CALLS

You may be among those fortunate few who haven't received a jury questionnaire or a call to jury service in recent years. In fact, you may be among an even more select group who have never been summoned to serve. But the chances are increasing each year that your turn in the courthouse is closer than you think.

True, that warning has been sounded repeatedly over the years. There has always been a sharp outcry of public indignation every time a celebrated crime case ends in a hung jury or when an underworld personality draws a light sentence. Jurors and jurists frequently share the criticism leveled at the courts for the justice dispensed...or the lack of it.

Today, however, there is a growing demand for juries of real peer groups instead of panels of primarily unemployed and retired, as well as other stereotypes. The increase in litigation at the local, state and federal levels and the overabundance of attorneys—a dilemma the president of the American Bar Association lamented at the ABA's national convention—have irritated citizens and caused community leaders to urge reform of the court administration to ensure its credibility.

But the system, some believe, won't yield easily to change.

The public goal of most jurists, jury commissioners and attorneys is to create a jury service plan that provides random, impartial selection, efficient use of court time and the least disruption possible for the prospective juror. "It is probably more important to the system to have the juries ready, willing and able to come into the courtroom and go to work than actually participate in the trial process. This type of benefit is probably impossible to communicate to the general public and especially to those persons who are inconvenienced by having to appear as a potential juror," a court official recently observed. "Frankly, we must make that our goal because the credibility of the system is shot to hell in some sections of the country," an exasperated attorney added.

A talk with some jurors about their experiences in court can produce angry tirades about delays, low pay and frustration at the hours of boredom.

"I had to serve twice in one year simply because of the inefficient selection process and the politics of the system. Several of my friends found ways out of it. Whether I'm in contempt or



by John C. Behrens

not, I simply won't be around the next time a notice comes," said an irate New York juror.

Such a comment isn't infrequent in a county or state where, officials concede, ineptness, legislative indifference or even political bungling have interfered with proper administration.

Says Geoffrey C. Hazard Jr., a Yale Law School professor and a reporter to the ABA Commission on Standards of Judicial Administration, "I am sure many systems still select on a non-random basis, and thus impose uneven burdens of service. On the other hand, I suspect some respondents to such a question tend to think of an unfair burden only if they themselves have suffered it. Jury commissions prefer to select from among those who will serve and hence may recall those who don't

decline. There is a conflict here between efficiency from the point of view of the system and fairness from the viewpoint of those summoned."

Jury commissioners in many states, for example, are required by law to select persons who are qualified electors. As a matter of convenience, these officials start with those who appear on the various poll books which each Board of Elections is required to keep.

In 1975, Prof. Hazard and others on the ABA standards commission drafted a report on management of the jury system and called for an overhaul. The report said, in part: "Each state should have a single jury selection statute applicable to all courts, governing all aspects of juror selection for all classes of cases...the only qualifications for service should relate to a minimum

age, U.S. citizenship, residency in the jurisdiction, the ability to read and speak English and exclusion of those who have not completed their sentence for conviction of a felony." Equally important, the committee continued, were the grounds for exemption.

"No citizen should be exempt from his obligation for jury service; the concept of exempting certain classes (occupational or other) of citizens should be abandoned. Necessary elimination of individuals should occur either through disqualification or excuse," the report stated.

Prof. Hazard believes the document has brought progress. "I think the changes will indeed actually increase the number of eligible jurors—they already have in Colorado and Texas and several other places. Of course, it hap-





## FUN AND FREEDOM

### Electrify



Your



Bike!

Ride away with your own silent exciting *electric drive system*. New patented non-polluting PEDALPOWER installs in minutes on the front wheel of any Bike or Trike. Allows easy pedaling when desired. Over 20,000 sold. Powered by latest 12-volt battery. Recharges at home. Ride 100 miles for a dime. Be independent! Improve your health! Enjoy the outdoors! Simple single lever control allows you to go where you want to, when you want to. Rebate plan and Senior Citizen time payment plan available! **MONEY BACK GUARANTEE.** Save \$15.00 - call toll free: 800-257-7955\* - or send today for \$15.00 coupon and free illustrated booklet. **Added bonus:** Receive free information on complete line of Electric Cars, Electric Bikes and Trikes.

**General Engines Co.**  
5260 Mantua Blvd.  
Sewell, N.J. 08080

Save  
**\$15.00**

\*In N.J., Alaska, or HI. - Call Collect: (609) 468-0270

# JURY DUTY CALLS

pens all the time that reforms are recommended but not adopted, or adopted nominally but not in substance. That makes reform frustrating but not necessarily futile.

Most frustrating are major states—such as Ohio and New York—which sift and sort changes but balk at sweeping reform. In New York, for example, the state legislature made slight alterations in 1978. For years, New York exempted women from jury duty simply because they were mothers and housewives. Empire state legislators changed the exclusion in 1975. Three years later, the state took airline pilots and newspaper editors and reporters off the exempt list. But the attorney-dominated legislature, similar to those in other states, refused to end exemptions. In fact, it added several more.

What bothered New Yorkers more, however, was the change in the law that required those who served less than five days to be subject to a recall to serve a minimum time. Before the change, a juror could serve two or three days, depending upon the length of the case, and not have to serve again for two years.

"We've got people who served in February who were called in again the first of March," Onondaga County, New York, Commissioner of Jurors Victor F. DelGiorno explained. "We don't want to call these people but we have to follow the law."

Generally, when jurors complain they usually criticize the discrimination and

unfairness of exemptions, jury commission officials say. "Many used to be able to understand why people involved with life and death jobs—doctors, firemen, and police for example—should be exempted. Now when they know their doctor doesn't make house calls and has as much vacation time as they do in some instances, they don't see why he's exempted. They don't understand why morticians, clergymen, lawyers, and dentists can get exemptions and they cannot," an attorney noted.

"The reasons lawyers are exempted," Prof. Hazard suggested, "is not the importance of their work but because it is thought that as 'experts' in law, they will have disproportionate influence in the jury deliberations. This may be a baseless supposition, in which event lawyers should not be excused, nor should doctors."

Some judges agree. John M. Kistler of the Court of Common Pleas, Miami County, Troy, Ohio, believes Ohio is already moving in that direction.

While some charge politics has prevented the establishment of effective jury systems in many states, Judge Kistler believes there are more basic reasons. "I practically never hear the charge in this county at least. Many people utilize every reason and excuse imaginable to try to get out of jury duty, though. This is a very human reaction and I probably would do the same thing; however, once they get involved, practically all agree that it was a worthwhile experience. Yet I am sure that specific areas are very political. This certainly should be stopped. But any generalization that the jury system is political is simply contrary to my experience."

(Continued on page 33)

**\$300 a Week ... Now I'm a**

**FULL TIME LOCKSMITH**

"Because of a disability, I needed work that didn't require much physical effort. I investigated Belsaw, and now I'm working full time earning as much as \$300 in a week."

Tom Tipton - Covington, Georgia

Make up to \$10 an Hour - Even While Learning! Send for facts! Don't let age, education or a handicap stand in your way. Be your own boss in a business of your own. Learn at home in spare time. All equipment and supplies furnished. Special tools, picks and a pro Key Machine are yours to keep. Send for facts. Accredited Member NHSC.

No Obligation... No Salesman Will Call

FREE BOOK

BELSAW INSTITUTE

139M Field Bldg., Kansas City, Mo. 64111

Please rush FREE Book "Keys to your Future."



NAME \_\_\_\_\_

ADDRESS \_\_\_\_\_

CITY, STATE, ZIP \_\_\_\_\_

## EXALTED RULER SHIELD

Present your retiring officers or lodge members with this beautiful walnut-finish trophy. Measures 9"x11". With solid

bronze emblem and plate...only \$13.25 F.O.B. Chicago (add 16¢ for each engraved letter).

Write for catalog.

To serve you better, we have moved to larger, more modern quarters.



**RUSSELL-HAMPTON CO.**

Dept. E, 2550 Wisconsin Avenue  
Downers Grove, Illinois 60515  
(A Chicago Suburb)

## Best Lodge Youth Program

Subordinate lodge youth activities chairmen should now be assembling their Best Youth Program brochures. The deadline for submitting brochures to the state youth activities chairman for judging is March 23, 1979.

The state winners in all membership categories will be declared by the state association youth activities chairman by April 6, 1979.

The state association youth chairman is to have selected a winner in each of five (5) membership groups and also to have selected a single state overall winner for the Best Youth Program and mailed them to me for consideration in the national Best Lodge Youth Program Contest by April 20, 1979.

If you have planned and carried through a well-balanced, year-round Youth Program you will have touched the lives of youths of all ages and helped them meet the challenges of tomorrow.

Bob J. Bybee, Member  
Grand Lodge Youth Activities Committee  
1430 Antares Drive  
Idaho Falls, ID 83401



# LODGE VISITS

## GRAND EXALTED RULER LEONARD J. BRISTOL



Woonsocket, RI, Brothers were honored by the presence of GER Leonard Bristol (second from right) for their 75th anniversary banquet. State Elks officials who greeted the GER were (from left) ER Lewis Andrews, SP Antonio Cabral, and SDGER Fred Quattromani.



The Grand Exalted Ruler, a guest for the 75th anniversary celebration of Queens Borough (Elmhurst), NY, Lodge, joined his fellow New Yorkers in enjoying the festivities. General Anniversary Chm. and PER Joseph Mansi (left) and Anniversary Ball Chm. Carl Sciortino (right) discussed the history of Queens Borough (Elmhurst) Lodge with GER Leonard Bristol (center).



A reception and a dinner were held at Ambridge, PA, Lodge for GER Leonard Bristol (third from right) and his wife Virginia. Pennsylvania dignitaries who were present included state sponsor PGER Homer Huhn, Jr. (fourth from left) and (from left) PDD Raymond Strickler, ER Raymond Pross, PSP Donald Oesterling, Grand Trustee A. Lewis Heisey, SP Carlon O'Malley, and DDGER E. Roger Zallon. The Bristols were escorted from the airport by a delegation of Pennsylvania Elks to Ambridge, where they were met by the mayor, Walter Panek, and given a tour of the town. During the Elks' reception the Bristols received a number of gifts from the ladies and the Brothers.

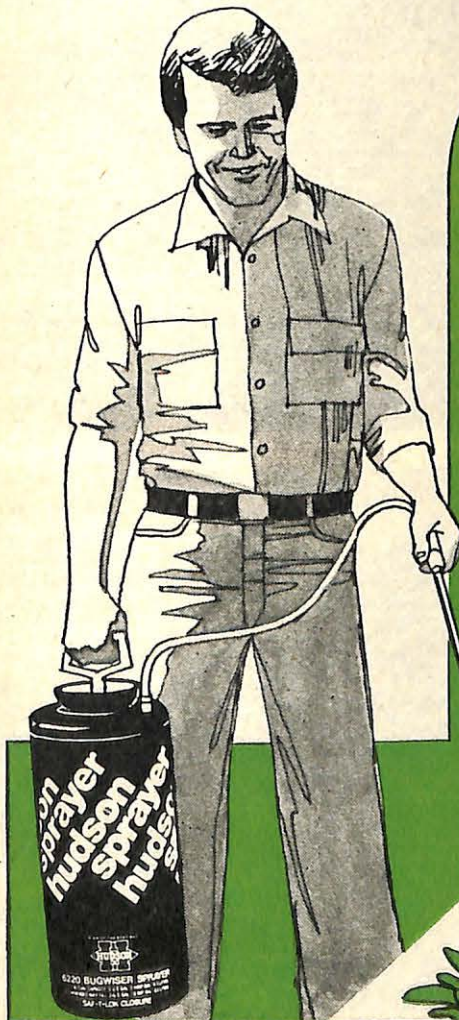

*Here's an easy, sure way to get rid of most lawn weeds.*

**"Sweep" them away with a Hudson sprayer!**

It's almost that easy to get rid of dandelions, plantain and other broadleaf weeds. With a Hudson sprayer, a quick, once-over "sweep" of weed killer can destroy

ugly weeds—roots and all. Easy to spot-spray, too. Go anywhere, no hose to drag. Also, you can mix the concentrate and water exactly as recommended for better results.

**Bugwiser®  
Compression  
Sprayer.**

America's popular all-around yard and garden sprayer. 3-gal. galvanized tank, brass pump, adjustable nozzle.



*Buy Hudson. How you spray does make a difference.*

**Duralite®  
Compression  
Sprayer.**

Polyethylene. Light, tough, corrosion-resistant. 1- and 2-gallon capacities.



**\$3  
FACTORY  
REBATE**

Details at Participating Dealers

For more information, write to Box 79B

SIGN OF THE BEST BUY



**HUDSON®**

H. D. HUDSON MANUFACTURING COMPANY  
500 North Michigan Avenue, Chicago, IL 60611

©MCMXXIII H.D.H. MFG. CO.



# SEAWEED:

## The Miracle Plant Of The 21st Century

by Doreen Buscemi

The storm had passed, leaving the waters of the Pacific calm once again. Sixty feet below the surface, just a short distance off the California coast, two divers were swimming slowly among the beds of giant kelp, a type of brown seaweed that can reach 200 feet in length. The massive fronds of the kelp waved gently over the divers' heads as they inspected the damage to the seaweed beds. As part of an experimental program to cultivate and harvest seaweed, these two divers, like good farmers everywhere, were concerned about the harm done to their crop by the violent storm.

Seaweed farming is no longer science fiction. In an effort to ease the energy crisis, seaweed is being cultivated to harvest the methane gas produced by the algae. In addition, aquaculture projects are beginning that include the harvesting of sea vegetables (seaweed, of course) to help feed the people of the world.

There are a myriad of other uses for seaweed. Chemicals gleaned from various seaweeds may soon be used to treat—and perhaps cure—everything from ulcers to malignant tumors. On the lighter side, seaweed extracts are being used to thicken jams and sauces, coat writing paper, add permanency to ink, and even put a head on beer. Seaweeds, those plentiful and often taken-for-granted plants of the oceans, may one day be one of the most valuable plants mankind has ever known.

In the hushed, sterile atmosphere of the operating theatre, Dr. Sannomyra Massanbu, of Kyushu University in Japan, was completing a delicate abdominal operation. There was something different about this operation, however. In place of blood plasma, Dr. Massanbu was using alginon, a gelatin-like extract from a species of brown seaweed. Alginon prevents the blood pressure from dropping too low and lessens the surgical risks.

Today, research laboratories across the United States and throughout the world are bustling with white-coated scientists busily uncovering countless medical uses for seaweed. One of the most dramatic possibilities is a treatment for cancer.

While researchers are quick to point out that there is no "cure for cancer," what they are patiently searching for is a substance that will slow down or possibly stop the growth of cancerous cells. When they find such a chemical, they know it might be possible to develop it into an anti-cancer drug.

In a number of experiments, various chemicals have been isolated from seaweed and then tested in tumors *in vitro* and in laboratory animals that have had malignant tumors grafted onto them. In some cases, the seaweed extracts have completely stopped the growth of malignant cells. Although it is a long road from laboratory animals to people, the hope persists and the research continues.

"Extracts of seaweed are also beneficial... in cancer therapy," reports Dr. George Ruggieri, a noted authority on marine medicine. Perhaps the worst aspects of cancer therapy today are the painful side effects that frequently occur. However, two physicians in Naples, Italy, conducted experiments in which patients suffering from bone cancer were treated with an algal compound after surgery or X-ray therapy. "The treated patients," continued Dr. Ruggieri, "were free of nausea, had improved appetites, and less painful symptoms than those normally associated with this form of cancer."

Somewhat less dramatic, but also very important, is that seaweed is a likely source of new antibiotic drugs. In recent years, some strains of bacteria have become resistant to penicillin and our other powerful antibiotics. New antibiotics are needed and *Sargassum*, a type of brown seaweed that gives

the Sargasso Sea its name, has yielded a strong antibiotic that appears to kill resistant bacteria. Some seaweed, including giant kelp, also appear to inhibit viruses.

The Chinese were the first to recognize the remarkable medicinal properties of seaweed. Centuries ago, they used seaweed to treat stomach disorders, abscesses, and even cancer. This isn't too surprising, however, since seaweed has always been an important part of Oriental cultures.

In the Orient, also, farmers have long farmed the edge of the sea. Here in the Western World, however, it took the energy crunch to get us seriously interested in seaweed farming. Today, everybody from General Electric to the U.S.

Navy is getting into the act. Probably the most ambitious endeavor to date is the Ocean Food and Energy Farm Project implemented by the Navy in San Diego.

The main thrust of this program is the production of methane gas from giant kelp. Methane gas is produced from seaweed by a very simple process. The harvested kelp is placed in large vats along with certain types of bacteria. The bacteria consume the seaweed and produce the methane gas as a by-product. Methane gas, of course, can be interchanged with natural gas for modern appliances.

In order to have a steady, reliable supply of kelp for methane production, it must be cultivated artificially since

there is not enough free-growing kelp. The seaweed farms envisioned by Dr. Howard Wilcox, head of the Ocean Farm Project, will consist of large artificial reefs located about 40 feet below the surface of the water. The kelp plants will grow on polypropylene lines and will be tended by skin-diving marine biologists.

According to Dr. Wilcox, a cultivated area that encompasses the same length as the distance between San Diego and San Francisco could provide enough energy to equal all of the natural gas presently consumed in the United States every year. But are prices competitive to energy produced by more conventional means? "The economic feasibility isn't there today," concedes Dr. Wil-

cox. "We can't compete with a flowing oil well. When the oil dries up, then hopefully the project will come into its own."

At the moment, four experimental farms are in use. The next phase of the program calls for the establishment of two large demonstration farms—one in the Atlantic and one in the Pacific. By 1990, Dr. Wilcox hopes that the project will be out of the experimental stage and that industry will be able to take over the seaweed farms.

Not far from Dr. Wilcox's seaweed farms, the harvesting of the natural kelp beds is moving along in full swing. The Kelco Company of San Diego, established in 1929, is the largest harvester of kelp in the country. The company



A harvester boat (left) returns home with a load of kelp, which is then processed to obtain algin (above). In the future, seaweed farms will be tended by skin diving marine biologists (below). All types of marine life live in kelp beds (right).





# Seaweed

does not process the kelp for methane gas but rather for algin, a very important industrial product.

Moving slowly, stern first through the strands of kelp, the submerged cutters of the harvester boat *Kelmer* mow a

20-foot swath, three feet down, through the kelp. The conveyor belts of the boat catch the seaweed and move it up into a holding bin. After about six hours of harvesting, the *Kelmer* sails back to San Diego with a full load of three to four hundred tons of wet kelp.

Once back on shore, each ton of kelp is refined down to 50 or 60 pounds of finished algin. Algin is used throughout

the world as a stabilizer in fruit drinks, marshmallows, and ice cream and as a thickening agent in a variety of things ranging from jams and jellies to certain medical products.

On the other side of the continent, the commercial harvesting of a type of seaweed known as Irish moss is big business along the shores of New England and Eastern Canada. This particular type of seaweed is so valuable because it yields carrageenan, an extract that, like algin, is widely used in industry as a thickener and stabilizer. Carrageenan may also have medicinal applications. The throats of soldiers who had been gassed during World War I were often soothed by carrageenan. It has also been used for years to keep medicines from settling; and now, recent scientific finds show that carrageenan may soon be useful in the treatment of a wide variety of illnesses—ranging from stomach ulcers to the flu. There is no synthetic substitute for carrageenan.

In the face of all these exotic uses for seaweed, however, it should still be remembered that seaweed may be the "miracle plant" of the next century simply by its ability to feed the world's people. Seaweeds are very nutritious plants that are much higher in protein than land vegetables. They are also good sources of iodine (a vital trace element) and the vitamins A, B<sub>2</sub>, B<sub>12</sub>, and C.

Although seaweed has always been a part of the daily diet in the Philippines, Japan, China, and the Hawaiian Islands, most Americans turn green at the thought of eating these vegetables from the sea. Yet Judith Cooper Madlener, author of *The Sea Vegetable Book*, writes that seaweeds "are not salty or fishy, as might be expected; some might be described as beanlike, nutlike, or similar to celery, parsley, or even grapes." And while she allows that a taste for seaweed must be acquired, she believes that it is no different from acquiring a taste for some of the stronger-tasting land vegetables such as cabbage or brussels sprouts.

Some westerners are already eating seaweeds and enjoying it. Pub-goers in the Canadian Maritimes eat dulse, a variety of red seaweed, instead of potato chips. And laver bread, made from another seaweed, is considered a breakfast treat in the British Isles. As scientists continue their research on the isolation of flavor enzymes, we may one day be eating seaweed that has been changed to taste like the finest cut of steak.

So, whether seaweed is feeding us, healing us when we're sick, or providing gas to keep us warm in the winter, seaweed is going to be a plant to be reckoned with in the coming century. ■

## Money isn't the only reason to start your own business



A lot of people start their own business for the pure satisfaction of it. Being your own boss. Making your own decisions. Establishing your own lifestyle.

If you too want the satisfaction of your own business, consider General Business Services.

GBS is one of the nation's leading small business counseling firms, with franchises in every state. We've started

nearly 1000 career-minded men and women on the road to their own business counseling practices. And we can help you get started, too.

As an independent GBS counselor, you'll work with other businessmen and women—right in your own community—providing the professional recordkeeping and management services almost every small business needs.

An investment of \$15,000 covers complete training, inventory and supplies, and the full technical support of our large national office staff. Even if you've never had formal training in business or accounting before, the time-proven GBS system can make you your own boss in just a matter of weeks.

Use the coupon below to find out more about the rewarding career opportunity GBS offers you.

© 1979, General Business Services, Inc.

Please send me your free brochure, "Invest in Your Own Future," about a GBS career.

Name \_\_\_\_\_

Address \_\_\_\_\_

City \_\_\_\_\_ State \_\_\_\_\_ Zip \_\_\_\_\_

Phone \_\_\_\_\_



Robert Turner, Vice President  
General Business Services, Inc. Department EM-U-3  
51 Monroe Street, Rockville, Maryland 20850



## RETIRE IN FLORIDA'S

### FINEST MOBILE HOME COMMUNITY

From only \$22,900 on Florida's Atlantic Coast there is beautiful lake country where you can retire on a sensible budget in an adult community of doublewide mobile homes.

Phone toll free 1-800/237-9494 for more information on how to get full enjoyment out of Florida retirement living. Or fill out the coupon. →

**VILLAGE GREEN**

at Vero Beach / A Lakefront Community

of Distinctive  
Mobile Homes



MAIL TO: VILLAGE GREEN  
Dept. 3703 P.O. Box 2823,  
Vero Beach, FL. 32960.

Name \_\_\_\_\_

Address \_\_\_\_\_

City \_\_\_\_\_

State \_\_\_\_\_ Zip \_\_\_\_\_

Phone \_\_\_\_\_



# Jury Duty Calls

(Continued from page 28)

The charge may have emanated erroneously, some jury commissioners believe, because the commissions have to change their procedures to meet legislative and court requirements. Oneida County, New York, Commissioner of Jurors Kenneth Cook says he has been challenged by attorneys and minority groups for not having enough women and minorities serving on juries. He points out that juror cards are not marked as to color or race, so such information simply isn't available.

He also faces criticism that there aren't enough young people among those serving on juries. "We have made a diligent effort. We even went to a local community college to get names and had the election bureau send us names of new voters in an attempt to get young voters. But many of those we got either went on to colleges elsewhere or moved out of the county to work. At least we tried. We've done everything we can to build the list of women, and we've more than doubled our figure." At the same time, he noted, the exemption of nurses could be another setback.

The same problem exists in other counties, too. According to reporter Michael Connor who wrote about jury duty in Rensselaer County in eastern New York, white collar workers normally dominate jury panels. Said Connor of one jury term: "Only 10 or 5.2 per cent of the 192 panel members were in their 20s; 17 were between 30 and 35. The average age of the jury panel was 48.8—the median age of the county in 1970 was 28.8. In short, the usual jury panel member in Rensselaer County is a middle-aged man working in an office...the usual defendant is likely to be under 35 and a man."

And what about pay? Oneida County jurors receive \$8 a day and 8 cents a mile. In Rensselaer County, a juror is paid \$5 a day. On the other hand, Wayne County, Michigan, paid its jurors \$15 a day and mileage in recent years and Miami County, Ohio, residents receive \$10 a day to serve as a juror. Rate discrepancies, though, occur throughout the country and, furthermore, an employer does not have to compensate an employee if the employee elects to accept the court fee. The ABA believes that a minimum of \$20 a day should be paid, plus round-trip mileage and the daily cost of parking if the court does not provide a parking lot.

The public, Cook suggests, doesn't understand the effort most commissioners make to maintain representative

lists of prospective jurors. "People ask why we don't go to one of the predominantly black housing projects to get names of minorities. One man asked why we didn't take his father-in-law instead of him, but that would be hand-picking jurors which is against

the law." Each year, one commission office assistant said, the process seems more difficult. Of approximately 5,000 persons screened "we're lucky if we get 2,300 out of that number to serve. You'd be surprised how indispensable people

(Continued on page 39)

Father Flanagan's  
**Boys Town**  
Boys Choir

Now Booking  
**34th ANNUAL  
CONCERT TOUR**  
Fall of 1979  
Midwest and West

Write: Father Robert P. Hupp  
Boys Town, Nebraska  
68010



Frank Szynskie  
Director

## Good News for Model Railroaders!



I'll never forget when I was given my first train set. My father and I played with it every chance we had.

As years went by, we added houses, scenery, and as many parts as we could find to build up our model train layout.

We even joined a club with other railroad hobbyists, but there was one problem we all had—we just could not find any place that offered a complete selection of quality "HO" and "N" parts and accessories.

That's when I decided to do something about it and started manufacturing railroad models for "HO" and "N" scale. But I insisted on only the very finest quality possible. As my business grew, more and more people told me how pleased they were with what I offered to railroad hobbyists.

Today my catalogs and idea books contain more than 10,000 different items for railroad hobbyists including accessories for "HO" and "N" scale—locomotives, cars, scenery, signals, structures—you name it—we probably have it.

If you are a beginning Model Railroader I am sure you will enjoy reading this 225 page "Model Railroading Handbook", it covers all aspects of building a model train layout from the ground up.

If you are already an experienced model railroader, or want to buy something for a friend or a relative who is, you will want to order one of our colorful catalogs so you can start adding to that model railroad empire right away.



1025 Industrial Drive,  
Bensenville, Ill. 60106

I enclose \_\_\_\_\_ for the following:

- Model Railroad Handbook (all scales) 225 pages \$7.95. Please tell us what scale you are interested in so we can send you more information.
- Complete 200 page "HO" catalog \$5.00.
- Complete 160 page "N" scale catalog \$4.50.
- Lionel 0-27 brochure \$1.00 (refundable).
- Books and photos on real railroads histories \$1.00 (refundable).

If I am not satisfied I may return for full refund (within 15 days).

NAME \_\_\_\_\_

ADDRESS \_\_\_\_\_

CITY \_\_\_\_\_

STATE \_\_\_\_\_ ZIP \_\_\_\_\_

E 39 © JMC 1979



# Loneliest Man

(Continued from page 8)

She says she understands why Hess refused until 1969 to permit her or their only child—a tall, blonde son named Wolf—to come to Spandau.

"He couldn't stand us to see him living like a caged animal," she says.

Except for exercise periods, when he marches listlessly about the prison yard in a black overcoat with a white numeral seven stenciled on its back, Hess generally lies on the floor of his 7-by-10-foot cell and practices yoga.

Since he is now the only prisoner in a deteriorating prison that is exceedingly expensive to maintain, Western officials are wondering what to do with him. Hess' lawyer has asked for his release on the ground that no law makes preparing or engaging in an aggressive war a crime. He also contends that Hess in 1946 was suffering from latent schizophrenia and should never have been tried at Nuremberg because of his illness.

But chances of Hess' release appear very slim. All four powers would have to approve it and the Russians have indicated they would never consent. The Russians feel anything that keeps alive

the memory of the Nazi regime serves a useful propaganda purpose in the Cold War.

If Hess remains in detention, some Western officials would like him transferred from Spandau. The total upkeep of the prison for its sole inmate is more than \$300,000 annually.

The question of Hess' mental state is still undetermined. One Western official who has seen the reports of his periodic psychiatric checkups says: "For a man who has been in jail for over 30 years, Hess is not mentally unbalanced." Another official claims Hess is mentally alert although he never talks about anything but his health, food and the weather.

The three Western nations do not believe Hess is legally insane. If he must remain in prison they want to transfer him to other quarters. Nonetheless, Hess may well remain in Spandau and continue to be the loneliest man in the world.

Annually for several years, the United States, Great Britain and France have formally requested that Hess be permitted to spend his remaining years with his wife, Ilse, now 78, and son, Wolf, a 40-year-old Munich engineer. But the Russians adamantly refuse. Soviet representatives keep using their veto power to reject the proposal. Why?

"He would become a symbol for all the Nazi groups still active in Germany," a Soviet journalist commented.

Hess, according to the few witnesses who know his mental state, has never regretted his early allegiance as chief deputy to Adolf Hitler. He was convicted of conspiring with Hitler and other Nazis to start a war of aggression and to break world peace. Of the seven Nuremberg defendants sent to Spandau, three had life sentences, but only Hess remains.

"If they ever let him out, he will prove to have risen above his ordeal," Albert Speer, a Nuremberg defendant who left Spandau 12 years ago, said not long ago.

In addition, many Western experts believe that Hess has never fully explained, at least publicly, the reasons for the mysterious solo flight he took to England in a Messerschmitt fighter plane in May, 1941, just over a month before the Nazi army invaded the Soviet Union.

Hess has always claimed he had undertaken "a peace mission" and wanted to prevent further war between Great Britain and Germany. Soviet experts believe his purpose was to tell the British about the planned Nazi attack on Moscow and to arrange a deal so  
(Continued on page 52)



## THE JOY OF GIVING

Elks National Foundation

2750 Lakeview Avenue • Chicago, Illinois 60614

A recognition night was held at Sebring, FL, Lodge recently in honor of contributors to the National Foundation. Participating members (from right) Floyd Schumacher, John Austin, and Ed Eckert accepted their certificates from Chm. and Est. Lead. Kt. Jesse Melanson.



On behalf of the National Foundation, PER and Chm. John Golden thanked Brother Robert Howard for his contribution of \$1,000. Among those on hand to congratulate the donator was ER Birkby Leip of Bordentown, NJ, Lodge.

Chap. Donald Dewar (center) of Wakefield, MA, Lodge received his honorary founder's certificate from Chm. and PDD Frederick DeVries (second from right). Also present to congratulate the \$1,000 donor were (from left) DDGER Amable Morin, PER Robert Miller, and ER William Rice.





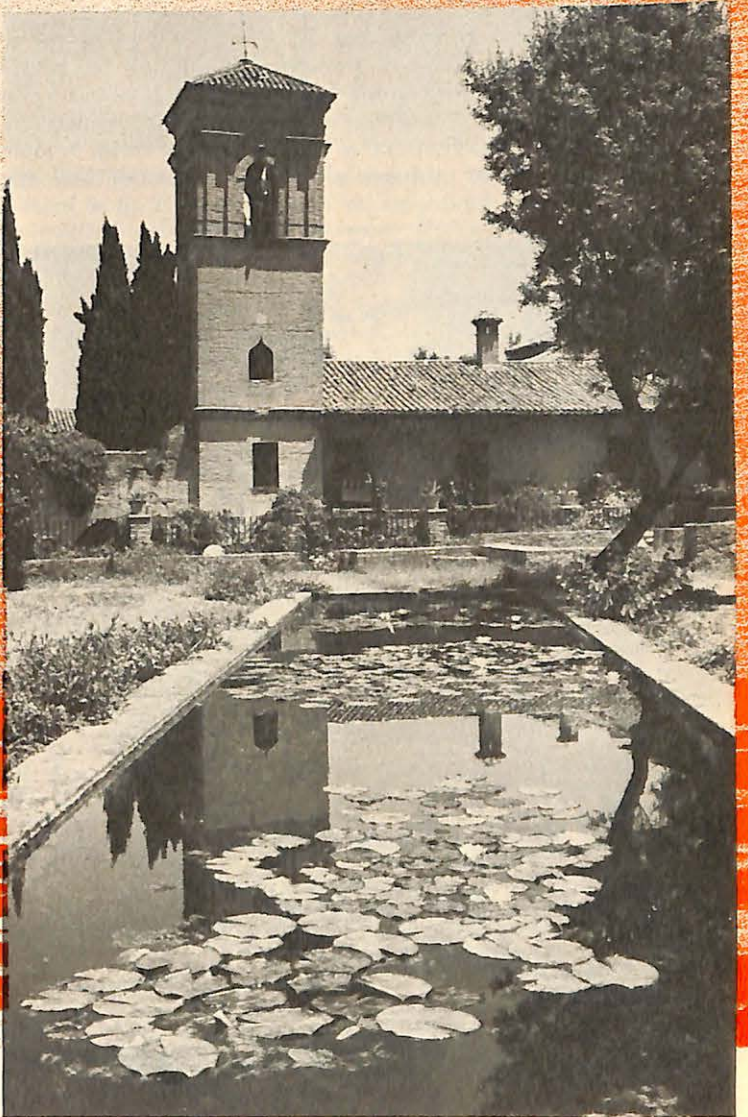
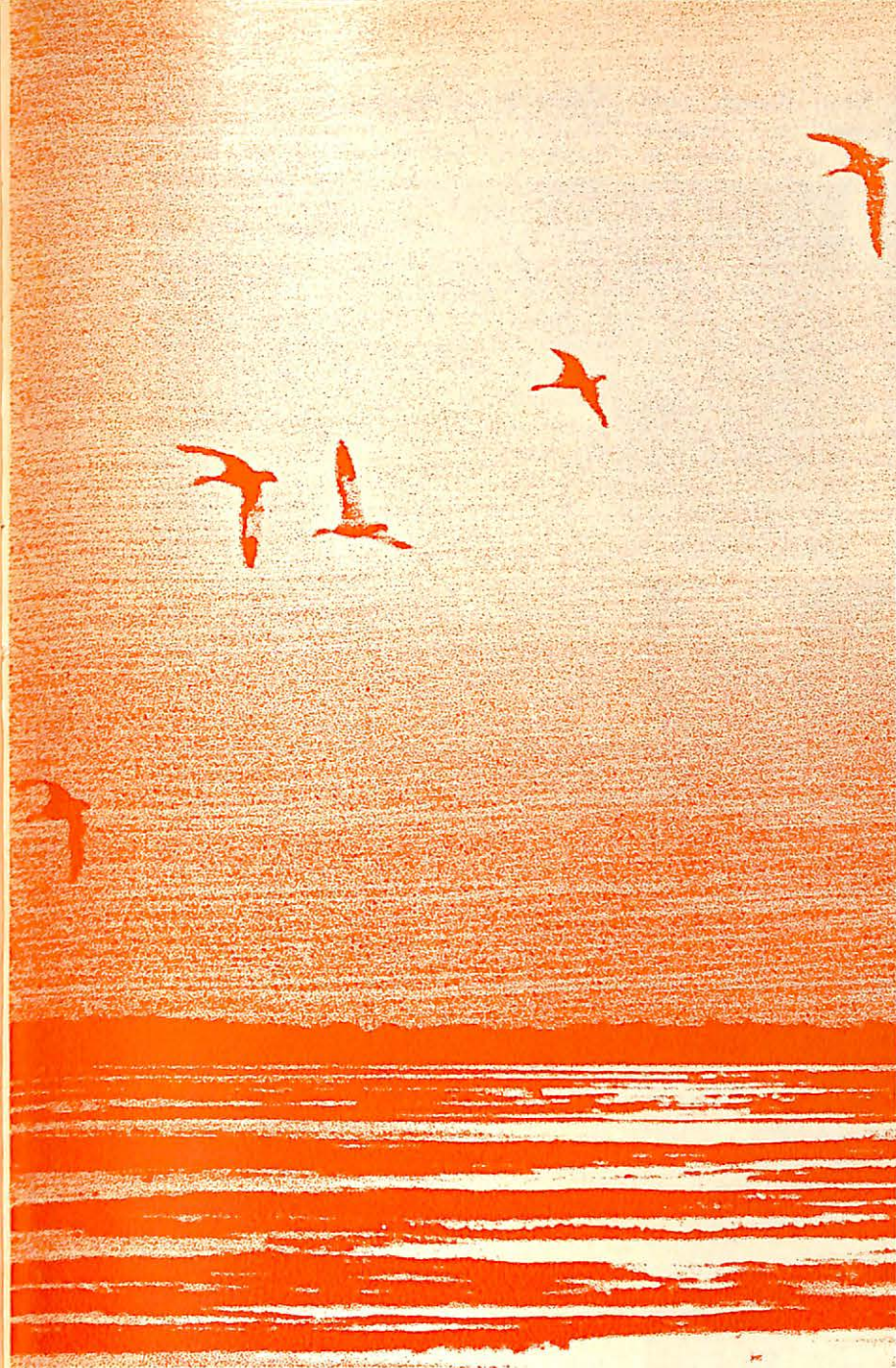

*Convents and monasteries have been converted into tourist shelters, such as the Granada parador (right).*

# The Paradores of Spain

by Jerry Hulse

Gulls wheel against the gray Spanish sky and far out to sea a single fishing boat rocks on heavy swells. Waves roll toward the rocky, twisting coastline of Bayona and the lone fisherman becomes lost in the growing darkness. Black clouds gather on the horizon and soon the sky and the sea are one and the same. Total darkness is only moments away; and now in the twilight hours the village of Bayona is at peace with the world. It is particularly restful at Conde de Gondomar, a magnificent Spanish parador occupying a prominent

position on the peninsula of Monte Real, with steep cliffs and private grounds and striking, manicured gardens only a few miles from the Portuguese border. During the day, guests hike to beaches nearby to sunbathe and listen to the melody of the surf and to play among the tide pools. In all of Spain, few paradores compare with Conde de Gondomar, a special place set along the Atlantic with the privacy of a royal estate near the fishing village of Vigo. Honeymooners find it particularly romantic. Indeed, there is a wedding chapel

where couples are united; afterward, they need only stroll the few yards to the privacy of the parador. The 45-acre peninsula on which the parador rests is surrounded by castellated walls, with access to a modern yacht basin, a swimming pool and tennis courts. Constructed on the site of a palace, it features Renaissance furniture, antique clocks and suits of armor. One half-expects some swashbuckling knight to come ambling down a hall, or else to encounter Douglas Fairbanks leaping from a staircase to a chande-



# Spain

lier, sword in hand, lashing out at the enemy in the remake of some half-forgotten film. Julius Caesar fought nearby.

More importantly, it was from one of the battlements at Bayona that inhabitants glimpsed the first of Columbus' three caravels returning home from the New World. Later, Sir Francis Drake was repulsed by defenders at Bayona and pirates sought refuge along its

craggy coastline. Now, though, only visitors invade Bayona and Parador Conde de Gondomar, whose rooms in the low season are offered at pre-inflation prices of \$7.50 a day single and \$10 double. In summertime, the rates are hiked to \$14.85 and \$18.60, tax and service included. (For an extra \$11.75 they'll provide all three meals.)

Throughout Spain the parador (as well as the more modest albergue) continues to be Iberia's finest bargain, with shelter provided for as little as \$3.50 a night. During the high season, one may remain up to 10 days in a parador and 48 hours at an albergue.

While the albergue often resembles a modern motel, the paradores generally occupy an old palace, a convent or monastery that has been renovated or reconstructed.

One of Spain's popular paradores, the San Francisco, adjoins the Alhambra and the gardens of the Generalite at Granada. Originally, the San Francisco was an Arabian palace and after this a convent. Reservations should be made six months in advance. Some travelers I know book a year ahead, which gives you some idea of the popularity of this gem of a parador.

Another worthy of mention is Parador de Los Condes de Villalba near Lugo. With a dungeon-like dining room, great stone walls and impressive murals, it is reached by drawbridge. Again, one expects some knight to come rattling through the great doorway, sword drawn and ready to do battle. While researching *Iberia*, author James Michener was a frequent visitor to the Spanish paradores. To travel through Spain in such a manner, Michener confessed, "is to travel at its best and most reasonable." Spain's paradores are government-operated, featuring first-rate plumbing, immaculate kitchens and generally cozy guest rooms such as those provided in Bayona at Conde de Gondomar.

During '79, travelers will be seeking bargains as never before, and particularly so if Europe is on their itineraries, which from all indications it will be. Thus the parador, that European bargain of bargains, will be high on the popularity poll. It will, indeed, be a hedge against inflation. And in addition to giving the traveler a true taste of Spain, it offers shelter at rock bottom rates.

While many hotels across the continent project a certain sameness, the parador is something else. One night you may sleep in a castle, the next night in a monastery. For roughly half a century Spain has been restoring its paradores and creating others until presently nearly 100 of these bargain basement establishments operate across Iberia.

They are found near the big cities, the seaside, inland valleys, the Basque country and high in the Pyrenees—nearly everywhere a traveler chooses to go. In Cordoba I looked in on one (La Arruzafa) that offers trails for riding, pools for sunbathing and rooms with private baths and air-conditioning. All this for under \$15 a night.

And then there is the Gibralfaro overlooking Malaga and the Costa del Sol from a dizzying niche hundreds of feet above the Mediterranean. A total of 12 rooms are up for grabs at the Gibralfaro, but be forewarned: they are  
(Continued on page 38)



## Live at Continental Country Club

A distinctive mobile home community surrounded by natural beauty that recalls memories of small town living in a rural setting. Privacy and convenience that comes with living in an individual home on a landscaped homesite that you also own. The convenient Central Florida location puts you in touch with major shopping areas and most popular attractions. An affordable lifestyle — one that minimizes the cost of living without lowering your living standards. A challenging golf course (optional annual fee membership), modern clubhouse, restaurant and lounge are just part of the extensive facilities available for active recreation. Visit Continental this year and forget cold winters forever.

**Continental  
Country Club  
Community**

Located on State Road 44  
Wildwood, Fla. 32785 Box 101-EL

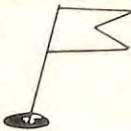

**YES!** Please send me more information

Name \_\_\_\_\_

Address \_\_\_\_\_

City/St/Zip \_\_\_\_\_

OFFER VOID WHERE PROHIBITED BY LAW



# NEWS OF THE LODGES

(Continued from page 18)



**BIRTHDAY CANDLES** were blown out by Cecelia Salter (center) on her 100th birthday recently. Delivering the cake and birthday wishes were Manistique, MI, Lodge's ER Vernon Annelin (right) and Est. Loyal Kt. Ernie Tweedie. Brother Tweedie is chairman of a lodge committee which provides birthday cakes for a local medicare facility.



**FOUR WHEELCHAIRS**, three commodes, and two walkers were contributed to St. Francis Hospital by Litchfield, IL, Lodge recently. On hand for the presentation were (from left) Est. Lead. Kt. Nick Wineburner, Sarah Krukoski, director of nursing services, Past GL Committeeman John Meckles, Robert Steinhour, director of the Elks Crippled Children's Commission, Frank Davis, Sister Hugh Holtmann, hospital administrator, Lonnie Nickles, Nina Millett, director of social services, PER Glenn Martin, and Marcia Eden, director of home health.



**AN ALUMINUM** can drive was organized by Grand Island, NE, Lodge recently. The proceeds of the endeavor totalled \$284.48 and were donated to the local veterans hospital. ER Bernell Shum (second from left) presented the check to Dr. Robert Munch (left), while vets Chm. Rudy Krueger (right) and Margaret Peterson, chief of voluntary services, observed.



**THE SIXTH** annual entertainment day was held by Baraboo, WI, Lodge for the patients of the veterans hospital in Tomah, WI, recently. The event included a tour of the Circus World Museum and the presentation of 42 deer hides. Participating in the occasion were (foreground, from left) Willard Munsell, ER Herbert Messer, Dale Williams, museum representative, John Gray, Chm. John Scharnke and (back) Jan Prell, hospital representative, Brother Morey Pierce, Joe German, and Mable Olson and Mary Ellen Wilson, hospital representatives.





# Spain

(Continued from page 36)

constantly in demand. One should write ahead for reservations several months in advance. Get busy this instant if you don't wish to be disappointed this summer.

Although the setting is less spectacular, I was impressed with the Parador de Nerja on the sea, 25 miles or so to the west of Malaga. Besides a pool and nearby beach, there are gardens, recreation rooms and a bar. It is also within short driving distance of Gibraltar and a number of excellent golf courses.

In all of Spain, though, no parador could possibly compare with Hostal de los Reyes Catolico, in Spain's spiritual capital of Santiago de Campostela, 60-odd miles north of Bayona. A five-star hotel, it was built originally as a pilgrim's hospital by Ferdinand and Isabella in the 15th century. It is operated by the Entursa Hotel chain and is unique in all of Spain. Although a hotel, it is more a museum, with 159 tastefully furnished guest rooms, including an immense suite once occupied by Generalissimo Franco. Gargoyles peer from the walls, and fountains play in the patios. The Franco suite demands \$62.50 a night, while ordinary rooms

are priced from \$18.75 to \$34.50. (The management threatens, however, to increase its rates by 25 percent.) Rising in the heart of the old city, the hotel faces the ancient square and the cathedral at Santiago de Campostela where, during the Middle Ages, pilgrims from every corner of Europe came to pay homage at the tomb of St. James the Apostle. Santiago de Campostela (the Jerusalem of the West) is ranked second only to Rome as a destination of the devout. All of this is tucked away in Spain's northwestern region. It is called Galicia and it has been discovered by few Americans. Mostly the tourist travels south to Seville and Granada or east to Valencia and Barcelona.

Unlike Madrid, Seville is old Iberia. Narrow alleys and whitewashed houses crowd the Moorish sections, surrounding courtyards with their musical fountains and bougainvillea. For those who become lost in the maze of streets, there are gentle souls who, for a few pesetas, will lead them back to the sun-washed area of the Cathedral of Seville. From there it is only a five-minute stroll down tree-lined boulevards to the Hotel Alfonso XIII, where countless crowned heads have spent the night.

For the traveler planning to do Spain or other European countries on a shoestring this year, it would be well to

remember Cosmos of London—one of the world's truly inexpensive tour operators.

Cosmos deals exclusively in inexpensive tours of Britain and the Continent. What they're selling is volume at the bottom dollar level, one of their cheapest trips being a seven-day tour of Brussels, Amsterdam, Bonn, Luxembourg and Paris for \$235. The air fare between the U.S. and Europe is extra, but the \$235 includes hotels and most meals in addition to sightseeing.

Because they are inexpensive tours, accommodations are in tourist-class hotels and family-run establishments. Few packages guarantee the traveler a private bath. Cosmos describes itself as "Europe's largest motor tour company." A majority of its customers jet to Europe by charter, such flights being booked by U.S. travel agents. Besides its London office, Cosmos operates in the U.S. at 69-15 Austin Street, Forest Hills, N.Y. 11375. Meanwhile, for other details on Spain, write to the Spanish National Tourist Office at 665 Fifth Avenue, New York 10022; 3160 Lyon Street, San Francisco 94123; and in the Midwest at 644 North Michigan Avenue, Chicago 61601.

(Note: Figures quoted in this article are subject to inflationary changes both in the U.S. and abroad.) ■

## ELKS NATIONAL SERVICE COMMISSION

"So long as there is a disabled veteran in our hospitals, the Benevolent and Protective Order of Elks will never forget him."



A 19-inch portable color television set was donated to the Albany Medical Center by the Brothers of Guilderland, NY, Lodge. The presentation was made to Dewey Robbiano (third from left), physician, during a veterans' dinner-dance at the lodge. (From left) Bruce Crate, dinner chairman, VP James Cornwell, ER Blaise Lambert, and DDGER Wallace Towle were among those who attended the affair.



Preparations for the shipping of hides to a tannery were undertaken by (from left) Jack Lewis, manager, ER Theodore Taylor, and PER Orville Figgs. The three Elks and their Brothers at Red Bluff, CA, Lodge collected the hides for the use of veterans, who will receive the leather after it has been cured and tanned.

Albuquerque, NM, Lodge recently saluted the nation's veterans with the initiation of a special class. Among the 39 new Elks who belonged to the "National Veterans Remembrance Month Class" was a group of local citizens who included veterans.





If you shouldn't climb stairs  
**INSTALL AN "Elevette"**

"Elevette" — the modern home elevator — can carry three adults or a wheelchair patient and attendant. It's custom built to the size best suited for your needs and serves two or more floors of your home. Tax deductible when doctor recommended. Free literature describes "Elevette" and stairway passenger lifts.  
**For Free Literature Call Toll Free 1-800-325-6400**  
Or write to  
**INCLINATOR COMPANY OF AMERICA**  
2217 Paxton St., Harrisburg, Pa. 17105  
In business for over 50 years

No paste or powder  
**holds dentures comfortably tight for weeks** like Snug Denture Cushions

Not a messy paste, powder, cream or wax pad—but an amazing soft plastic adhesive cushion. Snug® Brand Denture Cushions hold loose, wobbly dentures comfortably tight for weeks. With Snug there's no need to bother with messy daily "fixing." It lasts for weeks, sticks to your plate not to your gums, so easy to clean or remove. Get Snug Denture Cushions to hold your dentures tight and firm for weeks...in comfort. At all drug counters.

# BINGO



**Largest Manufacturer and Distributor of BINGO Supplies**

Free Catalogues available for:

- ★ Complete bingo supplies
- ★ Tables & chairs
- ★ Flags & banners
- ★ Armchair races
- ★ Jar & breakopen tickets

**ALL STAR BINGO INC.** Dept. E-3  
P.O. Box 346, Rockville Centre, N.Y. 11571  
Toll Free Call: 800-221-6706

**\* HEARING AIDS \***  
From \$89.50—30 Day Trial  
**GIGANTIC SAVINGS ON BATTERIES**  
Write For Free Gift Offer and Brochure Today  
**ELECTRONIC PRODUCTS**  
Box 2005-E, Pinellas Park, Florida 33565

**RUPTURE AGONY**  
DISAPPEARS . . .  
WHEN you slip into a Brooks Appliance! Why not the best for your reducible rupture? Not sold in stores. Write for our free booklet today.  
**BROOKS CO., Box 370-A, Marshall, MI 49068**



## Jury Duty Calls

(Continued from page 33)

become when they are called to serve on a jury."

Unfortunately, some former jurors believe they have very good reasons for avoiding the bureaucracy they found and for criticizing the system. "I was looking forward to jury duty, that's the irony of it," one said. "I sat in the jury room waiting for hours while judges and attorneys had coffee breaks and alleged legal discussions. Then I actually sat on one case that was dismissed after we waited for two more hours to find if, in fact, there was a case. You better believe I will be a reluctant juror the next time," she added, her voice rising with anger.

"I had to give up several days of work to travel some distance for court duty and both days were simply wasted. We met and sat, and I would have probably been there for the rest of the week at \$8 a day had I not been able to get out of it," another complained.

Although neither instance occurred in Ohio, Judge Kistler admits there is a serious problem in the use of court time. "I have to plead guilty to this charge. We do have inefficient court administration, and it is a matter we are constantly working on to improve. Jurors have a legitimate gripe in the number and length of unexpected delays in court proceedings. I have been reluctant to explain a lot of the delays in my cases because of the fear of what I would tell them might prejudice them in their decision in the particular case they are trying, or perhaps in a case they would have to sit on in the future.

"I think that I have been wrong because I really don't think jurors feel that they are required or entitled to know the actual reasons and details of the particular delays, but they are more interested in simply knowing something and having some idea of what is required of them and would be satisfied with just some indication as to how long the delays will be. Some delays in a trial are unavoidable, however. My experience would indicate that a substantial number of delays, perhaps 50 per cent, could be avoided by better preparation by everyone."

In its report, the ABA commission on standards stressed the need for efficient court administration throughout the country. "The judges of the court have the responsibility to see that jurors at court are utilized efficiently."

Meanwhile, don't get overly optimistic about the fact that you haven't voted in recent years; your name can pop up among a growing number of lists on your jury commissioner's desk. ■

## PLAN AHEAD FOR DERBY DAY MAY 5th

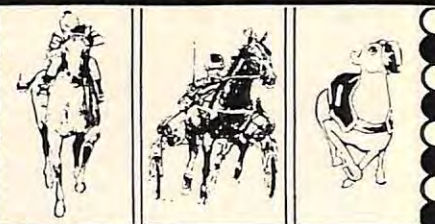

- THOROUGHBRED RACING
- HARNESS RACING
- GREYHOUND RACING

Whether it's Thoroughbred, Harness or Greyhound racing, A NITE AT THE RACES® offers the most unique "fun" and fund-raising program in popular use today.

A complete 16mm film package of actual races in vivid color with authentic track sounds and commentary which also includes official programs, mutuel tickets, play money, computation forms and daily doubles. Exactas and quinellas available. **PAST PERFORMANCES** and **MIXED FORMAT RACING KITS** are also heavy favorites with A NITE AT THE RACES.®

Write today for free brochure.

**a nite at the races, inc.**

2320 Ave. "U" • Brooklyn, N.Y. 11229  
Tel: (212) 769-7355

### Make Rubber Stamps for BIG PAY



Need more money? Earn \$60-\$75 a week, spare time, at home making rubber stamps for offices, factories, individuals. Hundreds of uses. Hundreds of prospects—everywhere. Right in your own community. Turn out special stamps for names, addresses, notices, prices, etc., in minutes with table-top machine. We furnish everything and help finance you, at less than bank rates. Write for free facts. No salesman will call.

Rubber Stamp Div., 1512 Jarvis, Dept. R-24-1C, Chicago, 60626

### PUBLISH YOUR BOOK!

Join our successful authors. Publicity, advertising, beautiful books. All subjects invited. Send for fact-filled booklet and free manuscript report.

**CARLTON PRESS**

Dept. ELO  
84 Fifth Avenue, New York 10011



### BOOK OF MEMORY

in everlasting bronze  
For listing 100 to 3250 names of deceased members economically. Write for free catalog showing photos of hand-chased cast bronze plaques.

**NEWMAN BROTHERS, Inc.**  
5625 Center Hill Avenue  
Cincinnati, Ohio 45216

### PARTS for CHAIN SAWS



Replacement chain, guidebars, sprockets, other parts at substantial savings. Also professional sharpening equipment, service tools. All first quality. Guaranteed. **FREE CATALOG.** Stores, shops give sales tax number for special dealer information.

Box 6329

Dept. K-106

**REPAIR PARTS**  
Erie, PA 16512



## Carry TEN TIMES a Wheelbarrow Load with INCREDIBLE EASE!

These BIG, strong carts are perfectly balanced on two huge wheels — roll easily over lawns and gardens — carry up to 400 lbs. of load — huge volume capacity means you make fewer trips — you'll save time and steps. If you are still struggling with a wheelbarrow or inadequate cart (with tiny wheels) send for FREE Cart Catalog. Build-it-yourself kits, too.

GARDEN WAY RESEARCH  
Charlotte,  
Vermont  
05445



© 1979 Garden Way, Inc.

GARDEN WAY RESEARCH  
Dept. 90123  
Charlotte, Vermont 05445  
Please send FREE CART CATALOG.

Name .....

Address .....

City .....

State ..... Zip .....



ACTUAL  
SIZE

## FREE STICK-ON PATCH

Beautifully embroidered, sticks to any surface — a perfect start for any collection. Order our full-color catalog of over 300 carefully crafted emblems featuring all states, cities, national and state parks, landmarks, major travel attractions plus many other subjects — each available for \$1 or less. Include 35¢ (cash, check or money order) to cover postage and handling.

Limited-edition 1980 Winter Olympic series. Collect this colorful assortment of Olympic Souvenir emblems and help support America's team.



Shown 1/4 Size

**Voyager  
Originals**

Box 512, Dept.-EL  
Sanborn, N.Y. 14132  
716-731-4121

35¢ enclosed for catalog postage and handling plus my FREE stick-on patch.

Name .....

Address .....

City ..... State ..... Zip .....

# Elks Family SHOPPER

Useful and unique  
new products for  
indoors and outdoors

## LIMITED SUPPLY OF PILOT'S GLASSES AVAILABLE NOW AT REDUCED PRICES!



ONLY  
**\$9.95**  
MONEY BACK  
GUARANTEE

These precision Flight Glasses are now available to the public for only \$9.95. If you could buy them elsewhere they'd probably cost you over \$20! Handcrafted, these glasses feature hardened metal frames, impact resistant polished glass lenses and selective ray-screening capabilities. Your satisfaction is absolutely guaranteed. If not satisfied, simply mail them back within 10 days. Your money will be returned.

To order, send check or money order (include \$1.00 for postage and handling) to United States Optics Dept. 6, P.O. Box 14206 Atlanta, GA 30324. (Please specify gold or silver frames) SPECIAL. Order now and get TWO PAIR for \$18 plus one dollar handling charge. (Deluxe, velour-lined vinyl cases also available for only \$2.00 ea.)

LIMITED OFFER FROM U.S. OPTICS



PORTABLE POWER CAN BE YOURS with Aquabug's 19 Pound Generator. Smaller than 1'x1'x9". Punches out 300 watts of 115 volt AC current & 12 amps worth of 12 volt DC current. Features electromagnetic governor, patented fuel pump system that re-cycles unburned fuel. 1 yr. warranty. \$275 Aquabug Intn'l, Inc. Dept. PR, 100 Merrick Rd., Rockville Centre, NY 11570



### THE EXALTED RULER

Charles M. Russell's Greatest Masterpiece

In 1912 he was asked if he would contribute something for the dedication of a new Elk's Temple. Russell painted the famous picture, "The Exalted Ruler", and signed it, "To My Brothers".

This beautiful print is 15"x20" with wide margins, reproduced in full color on canvas. This would make a very fine gift for a special Elk member such as your Exalted Ruler, your past Exalted Ruler, or would be a fine addition to your Lodge.

One canvas print is \$15.50, each additional print is \$13.00 if ordered at the same time. Mailing and handling incl. Satisfaction guaranteed. Send check to:

**MOUNTAIN MAN PRINTS**  
BOX 6611 Rm. 47, GREAT FALLS, MONT. 59406

## NOW! MAKE YOUR OWN BADGES BIG PROFITS, FUN, TOO!

Fill constant demand for colorful, plastic-protected, metal pin-back badges and buttons with the improved BADGE-A-MINIT Buttons, key-chains, purse mirrors sell fast at shops, malls, fairs. Take orders from clubs, schools. Parts cost just pennies each. Fun and profit for you creating badges. Write for free sample button and details or send \$24.95 (plus \$1.75 shipping and 5% tax—ill residents) for complete BADGE-A-MINIT containing die press, color-coded dies, one dozen badge parts, illustrated instructions.

GET FREE SAMPLE BUTTON AND  
NEW COLOR CATALOG

BADGE-A-MINIT Ltd. Box 618 Dept.E38, LaSalle, IL 61301

## CUSTOM MADE EMBLEMS

Organizations, Schools, Churches, Commercial Fund Raising and etc. Free Brochure Dept. CM 10E



EMBLEMATIC JEWELRY E15  
ELKS, K of C., MASONS, ETC. 75¢ ea.  
Free brochure Dept. EJ 12E p.p. 25¢  
Fraternal Wholesale Jewelry Mfg. Co.  
P.O. Box 8123, Cranston, R.I. 02920  
(401) 942-4591



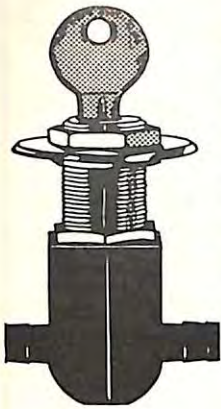

**MAKE YOUR CAR THEFT-PROOF** by installing an Inline Gas Lock. Takes only a few minutes. Anti-theft accessory works on any fuel-generated vehicle. Valve installs in the gas line and shuts gas off by the turn of a key. \$24.95 (MA residents add 5% sales tax) ATA Industries, Box 495, 164 Lindell Ave (Rear) Leominster, MA 01453. Dealer Inquiries Invited.

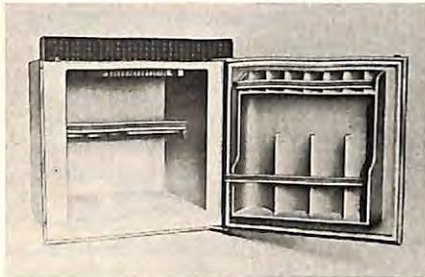

**SOLID-STATE FRONT-OPENING** refrigerator perfect answer for boaters and R.V. owners using a built-in icebox. The B42 uses thermoelectric modules instead of compressors, freon & gases. Never wears out or breaks down. Only moving part 12 volt fan motor that can be replaced. Total of 1.5 cu ft of useable space, holds up to 40 lbs of food & beverages. 1 yr warranty. Koolatron Industries, Ltd, 230 Bayview Dr., Barrie, Ontario, Canada L4N 4Y8



**TEST TUBE BABIETM**—the cloning of a perfect plant. Conceived in a laboratory by scientific process called tissue culture. Placed in a test tube in a completely sterile transparent environment. No care needed, just light, until it grows to the top of the tube—then ready for planting into the real world! Complete in gift box container with tube stand and birth certificate. \$5.95 + \$1.00 shpg. Setrian Enterprises, 1030 Wayne Ave, New Smyrna Beach, FL 32069



Outfit your officers and Lady Elks in these attractive blazers of 11-11½ oz. 100% textured polyester double knit with Elk buttons for year-around wear. Special emblems custom made for your lodge. Write for information and swatches. Blazers \$46.95 each. Buy with confidence from the official supplier of Ohio's Elk blazers.

THE VAN WERT MFG. Co.,  
Box 230, Van Wert, Ohio 45891

# THOUSANDS SOLD AT \$19.99! REAL DIESEL HORN

## Makes Every Car "King of the Road"

... even tiny compacts roar like a lion!



- Commands attention—can't be ignored!
- Could be a lifesaver in emergencies!
- Authentic tractor trailer horn!

A horn should be used with discretion, but when you *do* use it, you want it to be heard. *And heard it is*—with this precision-made electric diesel horn that gives any car the roar of a giant tractor-trailer. Now when danger threatens, you let go a blast you *know* won't be ignored. Now you are sure of getting your fair share of the road no matter what size or make car you're driving. Easily installed. Mounting brackets, simple instructions included. 12-Volt.

**CLARIDGE PRODUCTS, Dept. 56**  
2105 Lakeland Ave., Ronkonkoma, N.Y. 11779  
Please send \_\_\_\_\_ Diesel Horn(s) with complete money-back guarantee. I enclose check or m.o. for \$15.95 plus \$2.00 post. & handl.  
Name \_\_\_\_\_  
Address \_\_\_\_\_  
City \_\_\_\_\_ State \_\_\_\_\_ & Zip \_\_\_\_\_  
N.Y. Res. Add Applicable Sales Tax



**CALL TOLL FREE 24 hrs.,**  
Credit Card orders (800) 648-5311  
(in Nev. (800) 992-5710)

With Built-in  
**RADIO**

Your Own "Last of a Breed" Personal Collector's Item

## Cadillac CONVERTIBLE

A superb replica of the elegant 1963 Cadillac CONVERTIBLE with built-in SOLID STATE RADIO (battery included). The magnificent body (10" x 3½" x 2½") with its sleek long lines and silver-chrome colored finish is reproduced to perfection, including rubber tires. CONVERTIBLE production has stopped. Now is your chance to own this collection piece. If not delighted, return for refund within two weeks.

**\$19<sup>95</sup>**

A great gift for home or office

**HOUSE OF ORLEANS, CD-82** 2042 Armacost Ave., W. Los Angeles, Ca. 90025  
Ship \_\_\_\_\_ Caddy(s) at \$19.95 ea. plus \$2.00 shipping (Ca. residents add tax)  
Enclosed is \$ \_\_\_\_\_ (check or m.o.) or charge my acct.  Carte Blanche  Diners  
 American Express  Master Charge  BankAmericard Card expires \_\_\_\_\_  
Acct. No. \_\_\_\_\_ Signature \_\_\_\_\_  
Name \_\_\_\_\_ Address \_\_\_\_\_  
Apt. \_\_\_\_\_ City \_\_\_\_\_ State \_\_\_\_\_ Zip \_\_\_\_\_



# DO-IT-YOURSELF

FINE GRANDFATHER  
CLOCK KITS  
STARTING UNDER

**\$220**

(including movement and dial)

- Factory direct prices
- Heirloom quality
- Solid 3/4" hardwoods: black walnut, cherry, mahogany, oak
- Easy to assemble, parts pre-cut
- Solid brass West German chiming movements
- Money back guarantee
- Prompt shipment

MASTER CHARGE and BANKAMERICAN/VISA ACCEPTED

Write for FREE color catalog



**EMPEROR®**  
CLOCK COMPANY  
WORLD'S LARGEST MANUFACTURER  
OF GRANDFATHER CLOCKS

Dept. 807, Emperor Industrial Park  
Fairhope, Alabama 36532

WIND DIRECTION  
AT A GLANCE

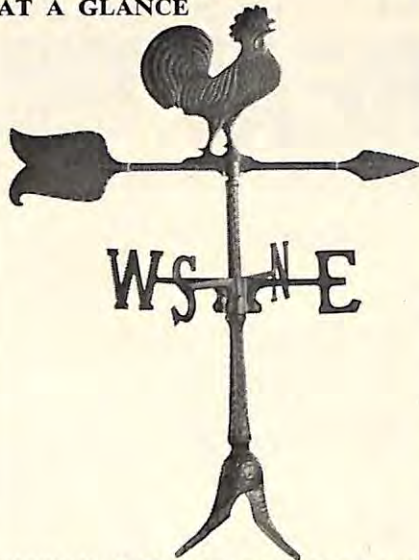

WEATHER VANES add the finishing touch to your country home! Perfect for your garage, farm or ranch too. Ornamental as well as useful. Precise wind direction at a glance. Balanced arrow responds to slightest breeze! These fine quality Weather Vanes are carefully handcast in aluminum and finished in satin black. Free from maintenance and rust proof to withstand decades of exposure. Complete with adjustable mounting base that will fit any pitched roof, horizontal or vertical surface. (Cupola base also available, specify) Arrow 18" long. Support 24" high. Great gifts.

Crowing Rooster \$12.97 + \$2.85 p&h

Galloping Horse \$12.97 + \$2.85 p&h

SAVE two for \$25.97 plus \$4.00 shipping.

Send check or M.O. 15 day money back guarantee

**HOLST, Inc.** Dept. EK-39, 1118 W. Lake, Box 370, Tawas City, Mich. 48763

## Elks Family Shopper consumer/news

The popularity of health foods has helped a lot of people become more aware of the food we eat and how it affects us. But consumers should be wary of claims that these foods offer special health benefits.

The Food and Drug Administration has a free reprint from its magazine, *FDA Consumer*, to help you sort the myth from the facts. For your free copy of *The Confusing World of Health Foods*, just write to the Consumer Information Center, Dept. 548G, Pueblo, CO 81009.

Part of the confusion about health foods, natural foods, and organic foods is that the stores selling foods under these titles don't have a clear idea of which is what. Are natural foods really "natural?" Natural seems to mean "as in nature," but the term is applied to everything from vegetables to bread to potato chips. Organic foods are generally thought to be free from pesticides. Yet many of the foods contain pesticide residues. Even if no pesticides are used, pesticides can remain in the soil for years. There is no way to define health foods other than to say that without food, none of us would be very healthy.

▶ Last week you had a thousand excuses for not visiting your parents at the nursing home. You still feel guilty.

▶ You scolded your child three days  
(Continued on page 44)



HIGH FLYING  
THRILLS!

The amazing,  
rotating airfoil

**ROLL-O-KITE®**

**\$3.50** each  
sent prepaid

The unusual design of this rapidly spinning airfoil makes it generate strong lifting forces. "A GREAT FLYER"! Feel the thrilling, whirling pull as it spins & climbs high into the sky. Amaze your friends as your kite soars above theirs! Quick, easy to assemble without glue or tools. 16 inch wide with 8 inch round ends. Complete with assembly & decorating instructions. Eleven piece kit includes all fittings. Hand-somely boxed for fun gift-giving. An excellent weekend family project.

\$3.50 each, 3 for \$10.00  
150 yards of flying string — \$ 1.50  
3 Kites & 3 flying strings — \$13.50

Canadian orders add \$1.00 per kite Calif. res. add 6% tax.  
Satisfaction guaranteed. Send check or money order to:

**RAFCO** Dept. EM-3  
3136 Kashiwa St., Torrance, CA 90505

## Cubic Zirconia...

There's  
Nothing  
Better

Cubic Zirconia is the world's most beautiful diamond simulant! Elegant, yet affordable... cut and polished with the same precision and care as a diamond... resulting in a resemblance that defies comparison! Direct from the cutter, at only \$40 per carat. Zirconia is a physical AND economical alternative to diamonds. Select the perfect size to suit your setting, or buy jewelry complete... 15 day money back guarantee. Write today for our free ring size chart and catalog.

**REGENT** Dept. E-39  
LAPIDARY CO. 2816 Morris Ave.  
Union, N.J. 07083

## New Natural Way To Sleep

100% Pure Cotton

Tee-PJ's resemble a T-shirt, but over a foot longer. Special knit gives when you move, eases up when you relax. No bind, no bunch, no chafe, no buttons, no ironing! Most comfortable sleeper you've ever worn or money back. (Great for Ladies, too). Choose snow white or soft blue. S-M-L-XL (to ensure best fit include height-weight when ordering.) Order NOW, while prices include postage/handling!

\$8. ea 3 for \$18

Long sleeve style (not shown)

\$10. ea 3 for \$25

**WITTMANN TEXTILES**

Dept. 259

Hobe Sound, Fla. 33455



**SAVE HUNDREDS OF DOLLARS!**

**WITH BURKE SEAT-LIFT CHAIRS**

**FREE Home Trial**

**Ask about Medicare coverage**

Now's the time to save hundreds of dollars with a comfortable Burke recliner. Burke seat-lift chairs let you stand and sit when you want, with less strain. Power recline to any position, automatically elevating your feet and legs. Write for information and compare.

**BURKE** P.O. Box 1064, Dept. E-3-9  
c. Mission, Kansas 66202  
or call TOLL FREE 1-800-255-4147



# ACCEPT NO SUBSTITUTE ZOYSIA!

## Lady Plugs in Genuine Amazoy Saves Time, Work and Money!



Amazoy is the Trade Mark Registered U.S. Patent Office for our Meyer Z-52 Zoysia Grass.

**EARLY BIRD SPECIAL! ORDER NOW AND GET UP TO 600 PLUGS FREE!**

By Jack T. Johnson, Agronomist

After 24 years of covering the lawns of America—coast to coast, border to border—Amazoy Zoysia could expect imitators to come into the market seeking to profit with a substitute grass.

We plant, cultivate, harvest and package Amazoy Zoysia according to a method so clever, so unique that we have applied for a patent to prevent anyone from copying it. Consumers' protective agencies constantly warn consumers, "Be sure you're getting the brand you're paying for; watch out for bait and switch people." So look for the name Amazoy (T.M. Reg. U.S. Patent Office) if you want the real thing—the world's best known Zoysia grass—Amazoy.

Our pre-cut plugs look different, are different. They are deep-rooted, winter-hardy plugs produced exclusively for transplanting from our fields into your lawn. They are guaranteed to grow there regardless of soil or climate. Why take chances with an untried grass? There really is no substitute.

### "MOWED IT 2 TIMES," WRITES WOMAN

For example, Mrs. M.R. Mitter writes me how her lawn "... is the envy of all who see it. When everybody's lawns around here are brown from drought ours just stays as green as ever. I've never watered it, only when I put the plugs in ... Last summer we had it mowed (2) times. Another thing, we never have to pull any weeds—it's just wonderful!"

Wonderful? Yes, Amazoy Zoysia grass IS wonderful! Plant it now and like Mrs. Mitter, you'll cut mowing by 2/3rds ... never have another weed problem all summer long the rest of your life!

And from Iowa came word that the state's largest Men's Garden Club picked a Zoysia lawn as the "top lawn—nearly perfect" in its area. Yet this lawn had been watered only once all summer up to August!

These represent but 2 of thousands of happy Zoysia owners. Their experiences show that you, too, can grow a lawn from part-shade to full sun, and it will stay green and beautiful thru blistering heat, water bans—even drought!

### PERFECT FOR SLOPES

If slopes are a problem, plug in Amazoy and let it stop erosion. Or plug it into hard-to-cover spots, play-worn areas, etc.

### CUTS YOUR WORK SAVES YOU MONEY

Your deep-rooted, established Amazoy lawn saves you time and money in many ways. It never needs replacement ... ends re-seeding forever. Fertilizing and watering (water costs money, too) are rarely if ever needed. It ends the need for crabgrass killers permanently. It cuts pushing a noisy mower in the blistering sun by 2/3rds.

**FREE PATENTED STEP-ON PLUGGER EXCLUSIVE WITH AMAZOY!**

This growth-producing 2-way Plugger is free with orders of 500 plugs or more. Saves bending, time, work. Cuts away competing weeds and growth at the same time it digs holes for plugs. Invaluable for making your own plugs for transplanting. Rugged, yet so light a woman can use it.

### WEAR RESISTANT

When America's largest University tested 13 leading grasses for wear resistance, such as foot scuffing, the Zoysia (matrella and japonica Meyer Z-52) led all others.

Your Amazoy lawn takes such wear as cook-outs, lawn parties, lawn furniture, etc. Grows so thick you could play football on it and not get your feet muddy. Even if children play on it, they won't hurt it—or themselves.

### Which Zoysia is best for You?

**DE LUXE AMAZOY** is our finest quality Meyer Z-52 Zoysia—the plugs that made Zoysia famous. Each plug has been cultivated and winter hardened for 3 full years to develop a mature, hardy root system with rope-like strength. De Luxe Amazoy plugs are available from us alone—hand-selected and cut to your order the day of shipment.

**STANDARD AMAZOY** is the younger Meyer Z-52 plug that we carry for the cost-conscious homeowner. It's at least 2-year old Zoysia with a hardy root system that's ready for plugging into your lawn. Firms who have never grown a blade of grass sometimes advertise this lower-priced Zoysia as if it were De Luxe Amazoy. It's not. Don't be misled.

**GUARANTEE:** Both De Luxe and Standard are genuine Amazoy plugs—100% healthy and winter hardened. **AMAZOY MUST GROW WITHIN 45 DAYS IN YOUR SOIL AND CLIMATE OR EVERY PLUG REPLACED FREE!**

### CHOKES OUT CRABGRASS

Thick, rich, luxurious, established Amazoy grows into a carpet of grass that chokes out crabgrass and weeds all summer long! It will NOT winter-kill. Goes off its green color after killing frost, regains fresh new beauty every Spring—a true perennial!

### NO NEED TO RIP OUT PRESENT GRASS

Now's the time to order your Zoysia plugs—to get started on a lawn that will choke out crabgrass and weeds all summer long and year after year.

Plug it into an entire lawn or limited "problem areas". Plug it into poor soil, "builder's soil", clay or sandy soils—even salty beach areas, and I guarantee it to grow!

### YOUR OWN SUPPLY OF PLUG TRANSPLANTS

Your established Amazoy lawn provides you with Zoysia plugs for other areas as you may desire.

Meyer Z-52 Zoysia grass was perfected by U.S. Gov't., released in cooperation with U.S. Golf Assoc. as a superior grass.

Order guaranteed Amazoy now, get your bonus plugs FREE. Your order will be delivered at earliest correct time for planting in your area.

We ship all orders the same day grass is taken from the soil, shipping/handling charge collect via most economical means.

© 1979 Zoysia Farm Nurseries

**DON'T BE MISLED! There is Only One Amazoy**

Amazoy plugs are taken from genuine Meyer Z-52 Zoysia ... guaranteed winter-hardened ... cultivated under the supervision of trained agronomists. Over a HALF-BILLION plugs sold (outsells the others 10 to 1)! So don't take chances with inferior plugs. Accept No Substitute for Amazoy Zoysia! If it isn't Amazoy, you're not getting the plugs that made Zoysia famous.

### PLUG AMAZOY INTO OLD LAWN, NEW GROUND OR NURSERY AREA

Just set Amazoy plugs into holes in ground like a cork in a bottle. Plant 1 foot apart, checker-board style.

When planted in existing lawn areas plugs will spread to drive out old, unwanted growth, including weeds. Easy planting instructions with order.

### NO SOD, NO SEED

Do not mistake Amazoy pre-cut plugs for sod or seed of any type of grass. There's no seed that produces winter-hardy Meyer Zoysia. Sod of ordinary grass carries with it the same problems as seed—such as weeds, diseases, frequent mowing, burning out, etc.

**FREE UP TO 600 PLUGS**

Just for Ordering Now!

More than a HALF-BILLION of our Zoysia plugs have been sold. Our Early Bird Bonus Plug Offer means clear savings to you. Order now. And if you don't want to take another chance with lawn disappointment remember:

*If it isn't Amazoy, you're not getting the plugs that made Zoysia famous. Accept no substitutes!*

**TO: Zoysia Farm Nurseries, Dept. 333**  
(Our 24th Year) General Offices and Store  
6414 Reisterstown Road, Baltimore, Md. 21215

Send guaranteed Amazoy checked below:

Full Size 2-Way Plugger \$4.95

	DELUXE	STANDARD
100 Plugs Plus Bonus of 30 Plugs FREE.	\$ 6.95	\$ 5.45
<b>Total 130 Plugs.</b>		
100 Plugs & Plugger Plus Bonus of 30 Plugs FREE.	\$ 9.95	\$ 8.45
<b>Total 130 Plugs.</b>		
200 Plugs Plus Bonus of 75 Plugs FREE.	\$11.20	\$ 9.45
<b>Total 275 Plugs.</b>		
200 Plugs & Plugger Plus Bonus of 75 Plugs FREE.	\$13.75	\$11.95
<b>Total 275 Plugs.</b>		
300 Plugs & Plugger Plus Bonus of 100 Plugs FREE.	\$17.75	\$15.45
<b>Total 400 Plugs.</b>		
500 Plugs & Plugger Plus Bonus of 150 Plugs FREE.	\$24.95	\$21.95
<b>Total 650 Plugs.</b>		
1000 Plugs & Plugger Plus Bonus of 300 Plugs FREE.	\$39.95	\$31.95
<b>Total 1300 Plugs.</b>		
1500 Plugs & Plugger Plus Bonus of 450 Plugs FREE.	\$49.95	\$40.95
<b>Total 1950 Plugs.</b>		
2000 Plugs & Plugger Plus Bonus of 600 Plugs FREE.	\$59.95	\$49.95
<b>Total 2600 Plugs.</b>		

I enclose \$ \_\_\_\_\_  Check  M.O.

NAME \_\_\_\_\_

ADDRESS \_\_\_\_\_

CITY \_\_\_\_\_

STATE \_\_\_\_\_ ZIP \_\_\_\_\_





**"SAVE YOUR HEART"**

with a **STAIR-GLIDE® Stairway Elevator**

**RENTAL-PURCHASE Program Available**

Your STAIR-GLIDE® installs easily and in less than 2 hours. No marring walls or stairway. No special wiring required. Shipped directly from factory within 4 days. STAIR-GLIDE®...the nation's largest selling stairway elevator! UL LISTED.

USED BY THOUSANDS: CARDIAC PATIENTS, ARTHRITIS, SENIOR CITIZENS, PHYSICALLY RESTRICTED, POST OPERATIVES...and household convenience.

WRITE FOR FREE BROCHURE AND NAME OF DEALER NEAREST YOU.

**AMERICAN STAIR-GLIDE® CORP.**  
4001 East 138TH ST., Dept. E-39  
Grandview, Missouri 64030



**WORLD FAMOUS HUMMEL PICTURES ON PENDULUM CLOCKS**

**Don't Pass Up This Offer!**

This famous multi-colored HUMMEL picture clock is enhanced with a handsomely decorative golden frame. Made in the hills of West Germany this 5"x7" clock is noted for its quality craftsmanship, which adds elegance to any room. The beautiful swinging pendulum maintains the accuracy of the clock. You could have this clock now for only \$19.95 plus \$1.00 postage. Send .50 for a brochure filled with other famous HUMMEL scenes.

SATISFACTION GUARANTEED

**TRAK IMPORTS, Dept. 13**  
P.O. Box 29128, Parma, Ohio 44129

**MAGNIFYING GLASSES**



**A Blessing For Folks Over 40**  
Read newspaper, telephone book, Bible and do close work easily. SEE CLEARER INSTANTLY. Not Rx or for astigmatism or eye diseases. 30 day trial. Sturdy, good-looking. Impact resistant lenses. Frames have metal hinges. State age and sex. **SATISFACTION GUARANTEED.** Order Now. Only \$6.98 + 75¢ handling. Precision Optical, Dept. 41-E, Rochelle, ILL 61068

**THE EVERYTHING BOWL**



**AT LAST — A bowl big enough to be really useful!**  
This 13 quart beauty is made from heavy gauge stainless steel and is as functional as it is attractive. 16" wide and 6" deep, it's perfectly proportioned for a variety of uses. For example:

- Toss and serve large salads.
- Mix stuffing, large batches of cookies, pie fillings, etc.
- Make bread dough.
- Fill with ice and use as a cooler for summer beverages, salad plates, etc.
- Bathe baby, soak feet, wash socks, bob for apples, catch drips, etc., etc., etc.

**We Guarantee you'll find many, many more uses for it!**  
Regularly \$20.00. Now yours for only **\$11.95!**

PLEASE RUSH ME \_\_\_\_\_ 13 qt. Everything Bowl(s) @ \$11.95 (plus \$1.75 shipping)

- \_\_\_\_\_ 8 Qt @ 7.95 (plus \$1.00)
- \_\_\_\_\_ 5 Qt @ 5.95 (plus \$1.00)
- \_\_\_\_\_ 3 Qt @ 4.95 (plus \$1.00)
- \_\_\_\_\_ 1½ Qt @ 2.95 (plus 75¢)

SAVE over 15%! \_\_\_\_\_ THE SET (All Five) @ \$29.95 (plus \$2.95)

**The Wooden Spoon® Inc.**  
Dept. 247, Rt. 6  
Mahopac, NY 10541  
Check, Money Order, American Express, Master Charge, or VISA please.

**Elks Family Shopper**  
**consumer/news**

ago, but it still upsets you. Guilt—we all have it from time to time. Is it harmful? Can it be useful?

A new publication from the National Institute of Mental Health discusses guilt feelings, where they come from, and how to handle them. For your free copy of *Guilt*, send a postcard to the Consumer Information Center, Dept. 578G, Pueblo, Colorado 81009.

Ever wonder how a physician can determine whether or not you have a **healthy heart?** The tests are painless and most are short.

The National Heart, Lung, and Blood Institute—one of the National Institutes of Health—has a new booklet that explains these procedures, some of which can be done as part of an office exam. For your copy of *How Doctors Diagnose Heart Disease*, send \$1.10 to the Consumer Information Center, Dept. 39G, Pueblo, Colorado 81009.

First the doctor takes your medical history. It is essential for you to be as open and complete as possible, for no amount of sophisticated technology can replace this important interview.

**CROCHET World OMNIBOOK**



**● MORE! MORE! MORE! New, exciting crochet patterns, designs, and features!**

**● At least 100 crochet patterns during the year!**

**● At a cost of JUST 3c per pattern!**

**● Four BIG issues a year!**

**\* SPRING \* SUMMER \* FALL \* WINTER \***

● If you love "Crochet World" you'll love the new "Crochet World Omnibook"

● Each GIANT 72 to 80 page issue a book in itself!

● A MUST for all crochet lovers!

● "Crochet World Omnibook" contains material all different from "Crochet World"!

● Each issue sells for \$1.00 - but if you subscribe, it's \$3.00 per year (SAVE \$1.00)!

Your money BACK if the first issue doesn't thrill you

**JUST \$3.00 PER YEAR**

Three years JUST \$8.00

\$1.00 each if bought separately

Save \$1.00 by subscribing

Rush your order at once

**CROCHET WORLD OMNIBOOK**  
Box 337-KT, Seabrook, N.H. 03874

1 year \$3.00	1 year Canada \$4.00
3 years \$8.00	3 years Canada \$10.00

Please print name and address clearly

Name . . . . .

Address . . . . .

City . . . . . State . . . . . Zip . . . . .

Please allow 45 to 60 days to receive your first issue.



See Advertisement Inside Front Cover  
**LAKELAND NURSERIES SALES, Dept. NL-1253**  
 Hanover, Pa. 17331

- Please send the guaranteed Zoysia Plugs checked below:
- |   |  |   |
|---|--|---|
| <input type="checkbox"/> FULL SIZE PLUGGER (L000778H) \$4.95                              | <input type="checkbox"/> 100 PLUGS (L000927Y) Plus Bonus of 25 FREE PLUGS \$5.88 (save \$1.47)       | <input type="checkbox"/> 100 PLUGS & PLUGGER (L000950Y) Plus 25 Free Plugs \$8.88 (save \$3.42) |
| <input type="checkbox"/> 200 Plugs (L000935Y) Plus 50 Free Plugs \$9.88 (save \$4.82)     | <input type="checkbox"/> 200 Plugs & Plugger (L000968Y) Plus 50 Free Plugs \$12.88 (save \$6.77)     |   |
| <input type="checkbox"/> 500 Plugs (L000943Y) Plus 125 Free Plugs \$19.88 (save \$16.87)  | <input type="checkbox"/> 500 Plugs & Plugger (L000976Y) Plus 125 Free Plugs \$22.88 (save \$18.82)   |   |
| <input type="checkbox"/> 1000 Plugs (L003293Y) Plus 250 Free Plugs \$29.88 (save \$43.62) | <input type="checkbox"/> 1000 Plugs & Plugger (L003301Y) Plus 250 Free Plugs \$32.88 (save \$45.57)  |   |
| <input type="checkbox"/> 1500 Plugs (L007633Y) Plus 375 Free Plugs \$38.88 (save \$71.37) | <input type="checkbox"/> 1500 Plugs & Plugger (L007640Y) Plus 375 Free Plugs \$41.88 (save \$73.32)  |   |
| <input type="checkbox"/> 2000 Plugs (L006288Y) Plus 500 Free Plugs \$47.88 (save \$99.12) | <input type="checkbox"/> 2000 Plugs & Plugger (L006296Y) Plus 500 Free Plugs \$50.88 (save \$102.12) |   |

I enclose check or m.o. for \$..... (PA residents add sales tax)  
 Shipped "Transportation Collect" the most economical way.  
**CHARGE TO MY:**  
 BankAmericard-VISA     Diner's Club  
 American Express        Master Charge  
 Carte Blanche             Interbank No. ....  
 Acct. No. .... Exp. Date .....

Name ..... (please print)  
 Address.....  
 City.....  
 State..... ZIP.....

**4 OLD HALF DOLLARS**  
**ALL SILVER - ALL OBSOLETE**  
**ONLY \$18.25**



Set includes the following Half Dollars: Barber, minted before 1916, Walking Liberty, minted before 1948, Franklin, minted before 1964 and a 1964 Kennedy, the ONLY Kennedy minted in silver.

**All 4 coins in a gift case - ONLY \$18.25**  
 Add \$1.00 postage. Brochures with order. IMMEDIATE SHIPMENT. Allow time for postal delivery. Satisfaction guaranteed.

**VILLAGE COIN SHOP**  
 Dept. E Plaistow, N.H. 03865



**JUST ONE HAND !**

A completely NEW concept in gardening machines! The amazing 2-in-1 TROY-BILT® Roto Tiller is not only a wonderfully better roto tiller, it's also a wonderful compost shredder-chopper! It turns your whole garden, however large or small, into a fabulously fertile "compost pile"! So easy to handle, even for ladies and older folks. You guide it with JUST ONE HAND! For complete details, prices, off-season savings, send coupon below for free booklet. TROY-BILT® Roto Tiller-Power Composters, 102nd St. & 9th Ave., Troy, New York 12180 © 1979 Garden Way, Inc.

**TROY-BILT® Roto Tiller-Power Composters**  
 Dept. 90553  
 102nd St. & 9th Ave., Troy, N.Y. 12180

Please send the whole wonderful story of TROY-BILT® Roto Tillers including prices and OFF-SEASON-SAVINGS now in effect for a limited time.  
 (Please Print Clearly)

Mr. \_\_\_\_\_  
 Mrs. \_\_\_\_\_  
 Miss \_\_\_\_\_  
 Address \_\_\_\_\_  
 City \_\_\_\_\_ State \_\_\_\_\_ Zip \_\_\_\_\_

# Sun Shield

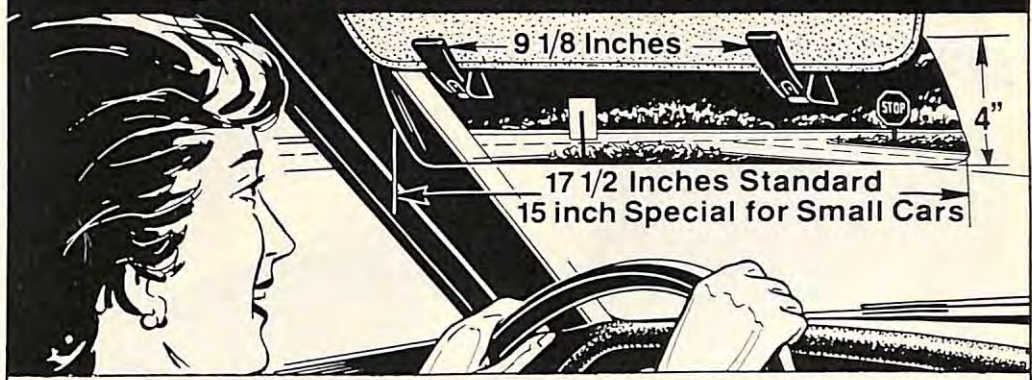

## DOUBLES your driving COMFORT

- Reduces ALL GLARE and HEAT, front or side, Day or Night
- Accepted by leading safety authorities • Positive screw clamps hold securely
- Universally adjustable for look-through or shade-and-look-under.
- SATISFACTION GUARANTEED (Return within five days for full refund)

THE IDEAL GIFT • MOST ENJOYED • MOST APPRECIATED

Sun Shields, Inc. • 9179 General Court • Plymouth, MI 48170



Check or money order enclosed; Michigan residents ONLY add 4% tax.  
 \$5.00 for one Sun Shield, shipped postpaid promptly.  
 \$9.00 for 2 Sun Shields - Make your passenger comfortable, too!  
 \$42.00 Doz. (minimum, one order) for group buyers - fleet owners.

Specify 15 in. LENGTH (not car model) for sub compact & small foreign cars.

Name \_\_\_\_\_ Street \_\_\_\_\_  
 City \_\_\_\_\_ State \_\_\_\_\_ Zip \_\_\_\_\_

## AT LAST A "WATERBED" FOR YOUR ACHING FEET!

- You literally walk on water!
- Instant relief from pressure on painful warts, calluses, bunions!
- No more hot, tired, sore foot misery!

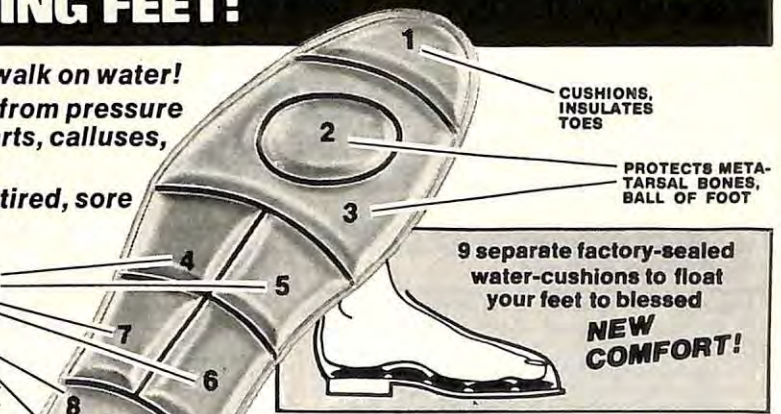

SUPPORTS ARCH, EASES MUSCLE STRAIN  
 ABSORBS HEEL SHOCK

CUSHIONS, INSULATES TOES

PROTECTS METATARSAL BONES, BALL OF FOOT

9 separate factory-sealed water-cushions to float your feet to blessed NEW COMFORT!

© 1979 American Consumer, Inc., Caroline Rd., Phila., PA 19176

MAIL NO-RISK COUPON TODAY  
 AMERICAN CONSUMER, Dept. FPW-206  
 Caroline Road, Philadelphia, PA 19176

I want the joy of walking on water. Please rush me the following (FPW) Aqua-Stride innersoles at \$3.98 per pair plus 50¢ postage & handling; 2 pairs for \$6.98 plus 75¢ postage & handling; 3 pairs only \$9.98 plus \$1 postage & handling.

Women's Sizes: (#007) Small (5-6) (#015) Medium (7-8) (#023) Large (8-10)  
 Men's Sizes: (#031) Small (7-8) (#049) Medium (8-10) (#056) Large (11-12)

If after receiving my order I'm not delighted, I may return it within 14 days for refund (except postage & handling). Total amount enclosed \$..... PA residents add 6% sales tax. Check or money order, no CODs please.

CHARGE IT: (check one) Exp. Date \_\_\_\_\_  
 Visa/BankAmericard     American Express  
 Master Charge Bank Number \_\_\_\_\_

Credit Card # \_\_\_\_\_  
 Name \_\_\_\_\_  
 Address \_\_\_\_\_ Apt. # \_\_\_\_\_  
 City \_\_\_\_\_ State \_\_\_\_\_ Zip \_\_\_\_\_

Canadian Customers please send orders to: Mail Store Ltd.  
 Dept. FPW, 312 Rexdale Blvd., Toronto, Ontario M9W 1R6  
 5513 (Ontario & Quebec residents add sales tax)



**NEW SPACE-AGE PAINT STRIPPER WHISKS LIKE A SPONGE!**

**Strips Away Old Paint, Varnish AND Years Of Accumulated Grime**



**Now Strip Away Anything FAST!**

- No Sanding • No Blasting • No Scraping • No Burning
- No Dangerous Power Tools • No Harmful Chemicals

**MEET THE STRIPPER!** It's space age science's super efficient paint and varnish remover that erases away, strips away, whisks away caked paint, tough varnish and years of grime with light easy strokes. That's not a promise—THAT'S A GUARANTEE! You'll be absolutely amazed at the results. THE STRIPPER moves across facades and veneers easily as it turns those caked, scarred, crusty surfaces into smooth, bare finishes F-A-S-T!

THE STRIPPER works just as well on all kinds of tough problems without sanding—without scraping—without burning or blasting—without harsh chemicals or power tools. So powerful it STOPS RUST DEAD IN ITS TRACKS as you erase those ugly stubborn patches down quickly to clean, bare metal. No hard rubbing! Just light erasing motions and you strip paint, varnish, rust, etc., from furniture, walls, doors, cabinets, boats, grills, cars, pipes, etc. Perfect for tackling thousands of tough, nasty jobs. It ends the need for sandpaper and caustic solvents.

The result of space age technology THE STRIPPER has thousands upon thousands of microscopic points that work efficiently and scientifically to strip away, whisk away, erase away old paint, rust and varnish with a simple erasing motion.

**RESULTS GUARANTEED—TRY AT OUR RISK**

The Stripper that looks and weighs like a sponge comes to you with this amazing "Use it and abuse it" no nonsense guarantee: Tackle your toughest jobs. Be amazed at how much labor the Stripper saves you. If you are not pleased and delighted with its incredible performance return within 14 days for a full refund of your purchase price (less postage and handling, of course). Order today.

This photographic accentuation helps depict the whisk-away action of the wonderful Space-Age Paint Stripper.

**DOES ALL THIS:**

- ✓ "Whisks-off" years and years of old paint.
- ✓ Strips away rust down to bare metal fast!
- ✓ Restores furniture to smooth paint-free finish.
- ✓ "Erases" years of grime and varnish as if by magic.
- ✓ Perfect for hundreds of jobs on walls, doors, cabinets, cars, grills, furniture, etc.

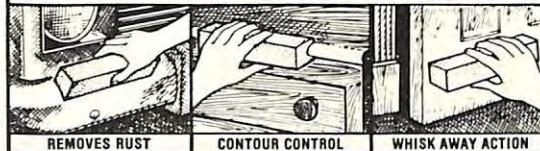

© 1978 Encore House, Inc., Roberts La., Glen Head, NY 11545

**MAIL THIS NO-RISK COUPON TODAY**

SPACE-AGE STRIPPER, Dept. SAS-63  
Roberts Lane, Glen Head, NY 11545

Please RUSH me the Incredible SPACE-AGE PAINT STRIPPER(s) with the understanding that if I am not completely thrilled and delighted with the way it completes my toughest jobs I may return for a full refund of my purchase price within 14 days (less postage and handling, of course). Check offer desired:

- (#001) 1 Carton of Six Strippers for only \$7.95 plus 50¢ post. and hand.
- (#002) **SAVE \$3.20!**—2 Cartons for only \$12.95 plus 75¢ post. and hand.
- (#003) **SAVE \$7.40!**—3 Cartons only \$16.95 plus \$1 postage and handling.

Amount enclosed \$ \_\_\_\_\_ (NY residents please add sales tax).  
No C.O.D.'s please.

CHARGE IT!  VISA (BankAmericard) Exp. Date: \_\_\_\_\_  
 Master Charge Date: \_\_\_\_\_

Credit Card # \_\_\_\_\_

Name \_\_\_\_\_

Address \_\_\_\_\_

City \_\_\_\_\_ State \_\_\_\_\_ Zip \_\_\_\_\_

**GIVE YOURSELF A LIFT!**

**CUSHION-LIFT®** Chairs are helping thousands of people stay independent and enjoy life with less pain. Now you can sit or stand at the touch of a button, and relax in comfort. Call today for a free home demonstration and descriptive brochure. Don't wait — give yourself a lift!

Call Toll Free: 800-558-2151



**ORTHO-KINETICS, INC.**  
P.O. Box 2000-EL3  
Waukesha, WI 53186  
Wisc. call collect: (414) 542-6060

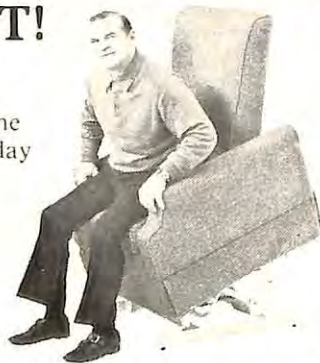

**STAMP GRAB BAG ONLY 10¢**

Giant grab bag of over 100 unassorted foreign stamps! Africa, Asia, Europe, South Seas, etc. Plus, wonderful price lists of U.S. & foreign stamps. Offer to ADULTS ONLY. Send 10¢ to: LITTLETON STAMP CO., Dept. G-80, Littleton, New Hampshire 03561.



**HONG KONG DOLLAR ONLY 10¢**

Send for this cupronickel dollar from the British Crown Colony of Hong Kong. One to a customer. SUPPLY LIMITED! ADULTS ONLY. Plus wonderful price lists. Send 10¢ to LITTLETON COIN CO., Dept. HK-3, Littleton, New Hampshire 03561.



**12 U.S. STAMPS ALL 50 TO 100 YRS. OLD—25¢**



Including the first U.S. Commemorative, the Landing of Columbus, issued in 1893! And 11 different old U.S. Stamps issued between 1873 and 1927. Plus our big list of stamp offers. Send name, address and only 25¢ to: MYSTIC STAMP CO., Inc., Dept. D-43 Camden, New York 13316.

Fast, Efficient, Reliable

**COMPOST BINS**

Turn garden and kitchen wastes into rich, fertile compost to improve poor soil and feed your plants. Grow bountiful harvests of vegetables and more beautiful flowers. Scientifically designed bins produce valuable compost in weeks. No turning the heap. Make a ton in one season. Send for FREE catalog:



**ROTOCROP**

150 Aero Park PATENT 3951294  
Doylestown, PA 18901

**Unique COIN COUNTER & PACKAGER**

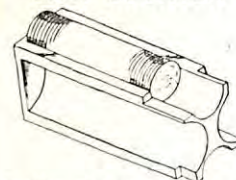

**\$2.80**  
2 for \$5.00  
3 for \$6.00

plus .40 (p-H)  
Pa. residents add 6% sales tax

Enables you to accurately count pennies, nickels, dimes and quarters in standard tubular coin wrappers. Plastic and pocketsize. Dealer inquiries invited.

**CHESSMAN CORP., Dept. E-7**  
307 Susquehanna Ave., Wyoming, Pa. 18644

**If Ruptured TRY THIS OUT**

Modern Protection Provides Great Comfort and Holding Security

An "eye-opening" revelation in sensible and comfortable reducible rupture protection may be yours for the asking, without cost or obligation. Full details of the new and different Rice Support will be sent you Free. Here's a Support that has brought joy and comfort to thousands—by releasing them from Trusses that bind and cut. Designed to securely hold a rupture up and in where it belongs and yet give freedom of body and genuine comfort. For full information—write today! WILLIAM S. RICE, Inc., ADAMS, N.Y., 13605 DEPT. 13V.



New sleep comfort without extra pillows.



Enjoy new comfort with your back, shoulders and head gently raised and cushioned on this light buoyant foam wedge. Provides an even, gradual slope for more healthful, restful sleep. Head Elevation comforts diaphragm hernia, hypertension, acid regurgitation, breathing, bronchial and heart ailments. Leg Elevation eases varicose, circulatory and swelling leg discomforts. 27" long, 24" wide. Washable zipper cover. FOAM-SLANT is available in heights most often prescribed by doctors. Order 4" high for two pillow users \$16.00, 7 1/2" high for three pillow users \$19.00; or choose extra high 10" at \$22.00 or 12 1/2" at \$25.00. Extra covers \$7.98 each. Order from this ad, we'll pay postage, ship promptly. NJ residents add 5% tax.

Send Check or Money Order to —  
**Better Sleep Inc.**  **MONEY BACK GUARANTEE**  
 Box ES, New Providence, NJ 07974 **QUALITY PRODUCTS SINCE 1951**

**TRY THE MOST EXPENSIVE CIGAR TOBACCO IN THE WORLD At My Risk**

We combed the imported tobacco markets to find the world's most expensive cigar tobaccos. We bid the highest for the finest . . . beautiful mild Cameroon, light silky Nicaragua, rich Mata-Fina from Brazil, plus the finest Santo Domingo Seco grown from Cuban seed. All blended by expatriate Cuban cigar makers into cigars selling for up to \$1 apiece in the luxury trade.

To find the 1 man in a thousand who appreciates the world's finest cigars, we offer a special sampler kit of 7 different size cigars for you to TEST SMOKE . . .

Send us nothing for the cigars, we've written them off as advertising samples. Just send \$1 to cover cigar tax, postage and expense and we'll send your 7 cigar Sampler Kit made from the world's most expensive cigar tobaccos. If you don't think they're the best cigars you ever smoked for less than \$1 apiece, return the empty 7 pack and we'll refund your dollar. Only 1 to a customer—good in U.S.A. only.

**WALLY FRANK, Ltd.**  
 132 CHURCH STREET DEPT. NEW YORK, N.Y. 10007 F193

Here's my dollar, send me postpaid the Sampler of 7 cigars on your money back guarantee. N. Y. Residents add sales tax.

(Print Name & Address Below)



**EVERYBODY'S STEAMCLEANER!**

**HOT DOUBLE OFFER!**

... and almost everyone is a prospect

**TAKE THE FOOLISHNESS OUT OF STEAMCLEANING**

- Air Conditioning
- Animal Farms
- Boats, Marinas
- Building Cleaning
- Business Machines
- Cafes, Hotels
- Cycle Shops
- Dairies
- Farms, Ranches
- Fish Markets
- Fur Farms
- Garages
- Ice Plants
- Industrial Plants
- Lawn Mower
- Meat Markets
- Print Shops
- Refrigeration
- Saw Mills
- Service Stations
- Super Markets
- Truckers
- Veterinarians



**SUKII . . .**  
 lightweight, quickfiring, long-lived, easy to operate, the choice of steam cleaners. L.P. gas fired and at a price users can live with.

**DESIGNED FOR SIMPLICITY. LOW MAINTENANCE COST—NO SMOKE OR FUMES.**

**BIG MONEY 2 WAYS SUKII** 

**1. DEVELOP YOUR OWN SUKII DEALERSHIP—Big Money Filling Demand All Over Your Territory**

Earn a giant \$200.00 profit per sale. Dozens of different kinds of businesses . . . service stations, garages, factories, farmers, etc. . . earn extra profits by saving time and work cleaning their property and equipment. Keeps customers happy, too.

**2. BE A SUKII EXCLUSIVE DISTRIBUTOR—Earn Biggest Profits, Realize Your Dreams**

Openings available right now for top-flight men and organizations qualified to step into the booming SUKII picture. Unique moneymaking program with protected territory.



Use your

- BankAmericard
- Master Charge

Send your name, account no., expiration date and identification no., if any.

MAKE YOUR SUKII PROFIT CHOICE AND MAIL COUPON TODAY!

**SUKII INTERNATIONAL** PH. 602-994-3270  
 P.O. BOX 1653 SCOTTSDALE, ARIZONA 85252

Produces Hot Steam **FAST!**

**\$289<sup>50</sup>** SHIPPED F.O.B. FROM FACTORY NEAR SIOUX CITY, IOWA

CLEAN UP RIGHT HERE

Get All The Facts!

SUKII Ph. 602-994-3270 Dept. E-3  
 P.O. Box 1653, Scottsdale, Arizona 85252  
 Tell me how to clean up with newly designed SUKII instant steam cleaning machine!

- Here's a check or m.o. for \$289.50—rush me demonstrator machine (\$499.50 retail value) and moneymaking details.
- Tell me how to get started as SUKII dealer.
- How do I qualify for that EXCLUSIVE FRANCHISE and PROTECTED TERRITORY as a SUKII distributor?

PHONE \_\_\_\_\_  
 NAME \_\_\_\_\_  
 SHIPPING ADDRESS \_\_\_\_\_  
 (Please do NOT use P.O. Box No.)  
 CITY \_\_\_\_\_ STATE \_\_\_\_\_ ZIP \_\_\_\_\_



Your Dollar Still Has Clout At RVP

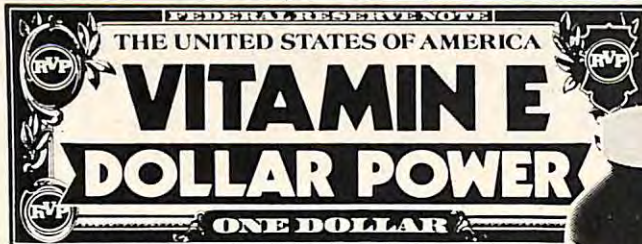

**\$ 1.00 BRINGS YOU 100 Vitamin E 400 I.U.**

Mail **\$1.00** Today To:

(LIMIT ONE BOTTLE PER HOUSEHOLD WITH THIS AD)



**Vitamin Products**

16 NASSAU AVENUE ROCKVILLE CENTRE, N.Y. 11570

8ELK-18

NAME \_\_\_\_\_

ADDRESS \_\_\_\_\_

APT. \_\_\_\_\_

CITY \_\_\_\_\_

STATE \_\_\_\_\_

ZIP \_\_\_\_\_

**"I am age 65 and retired. My friends joke about my second childhood but I sure enjoy the bike."** L.M. Dendy, Magnolia, AR

Super Tryke's your ticket to outdoor fun or economy (25 mpg) transportation. Reverse gear (option) and automatic, torque converter make handling a breeze. Select forward or reverse and go — always in the right "gear." All controls are hand operated. Double seat (option) is 24" off ground — no drop sitting or awkward climb getting up. Four-shock suspension and low pressure tires smooth any bumps. 11 H.P. Briggs & Stratton engine runs smoothly at moderate speeds to 45 mph. You assemble Tryke from an easy-to-build kit, save assembly costs. In 8-10 hours using common tools you'll have a quality, handcrafted machine. For information, send to:



Tryke brings outdoor fun to many retirees.

**Carl Heald, Inc.** Dept. EK-93, P.O. Box 1148, Benton Harbor, MI 49022

### HAPPY HANG-UPS

Whimsical, full-color plaques to give to special friends. One features a smiling airplane and proudly declares: "Pilots are just plane people with a special air about them." The other depicts a grinning adding machine and the observation: "Accountants are important sumbodies with well balanced personalities." Both framed plaques are 9½x12" and ready to hang. Satisfaction Guaranteed.

#HU-5005 Pilot..... \$5.95 postpaid  
#HU-5007 Accountant ..... \$5.95 postpaid

BILL COLLINGWOOD, Dept. E-3  
Box 294, South Miami, Florida 33143

"The YOL nique Catalog" 25c or free with order. Please allow 2 weeks for delivery.



**FABULOUS LOW PRICE ON THE POPULAR COACH'S JACKET!**  
WITH ELKS EMBLEM \$14.95 plus \$1.50 handling  
WITHOUT ELKS EMBLEM \$12.95 plus \$1.50 handling

A fantastic buy for the active man! 100% nylon taffeta with raglan sleeves, 2 slash pockets, snap front, drawstring bottom, elastic cuffs and cotton flannel lining for extra warmth. Navy, maroon and gold in sizes S, M, L, XL. 30-day money back guarantee. Quantity prices available on request.

ORDER NOW!  
**ABIC APPAREL**  
Box 248  
724 Winfield Road  
St. Albans, WV 25177



# PROSTATE RELIEF

Get rid of prostate misery. Relieve problems like pain, dribbling, urgency, retention and getting up nights. Write today for **FREE** report. **Health Dpt. EK-2, Box 24847, Los Angeles, CA 90024**

**FREE REPORT**  
Rush FREE report on prostate relief.

Name \_\_\_\_\_ Age \_\_\_\_\_  
Address \_\_\_\_\_  
City \_\_\_\_\_ St \_\_\_\_\_ Zip \_\_\_\_\_  
HEALTH, Dept. EK-2, Box 24847, Los Angeles, CA 90024

## The better haf

With HAF-A-JAMA, you decide which half is better. Available in both Uppa and Lova, stripes or solid.

Men order by suit size (36-50). Ladies order by blouse size. Solids are 100% cotton and are available in blue or gray. Stripes are permanent press and are blue/white or wine/white. **\$8.95 each**

2 for \$17.00. No COD's/money back guarantee/stripes may vary. Cotton or Flannelette Kneelength sleepcoats (as pictured) available for \$10.95 each.

Send for free brochure on full line of sleepcoats and HAF-A-JAMAs. Add \$1.50 HAF-A-JAMA postage & handling dept. E39 14 Mica Lane Wellesley, MA 02181 (617)235-5340



## WATER MINDER With Automatic Shut-Off Control



Now your lawn can have the proper amount of water and you'll never forget to turn off the hose. Just attach to spigot, set the Water-Minder dial for the amount of water desired... and **Forget IT!** Measures 0 to 1500 gallons and shuts itself off automatically. Has pilot valve for easier open and close under

any pressure. Water-Minder readily adapted to most water control situations, swimming pools, photo darkrooms, golf courses, industrial uses, etc. Saves you the bother of timing and of **WASTED WATER.** Made of high grade corrosion resistant materials. One year guarantee. Order now and **SAVE** on those water bills! Only \$11.50 plus \$1.50 post. Two for \$21.50 plus \$2 post.

Send check or M.O.  
20 day money back guarantee.

**HOLST, INC.** Dept. EK-39, 1118 W. Lake, P.O. Box 370, Tawas City, Mich. 48763



AMERICAN TREASURY PROUDLY PRESENTS

# The State Spoon Collection!

AS LOW AS 80¢ per Spoon!

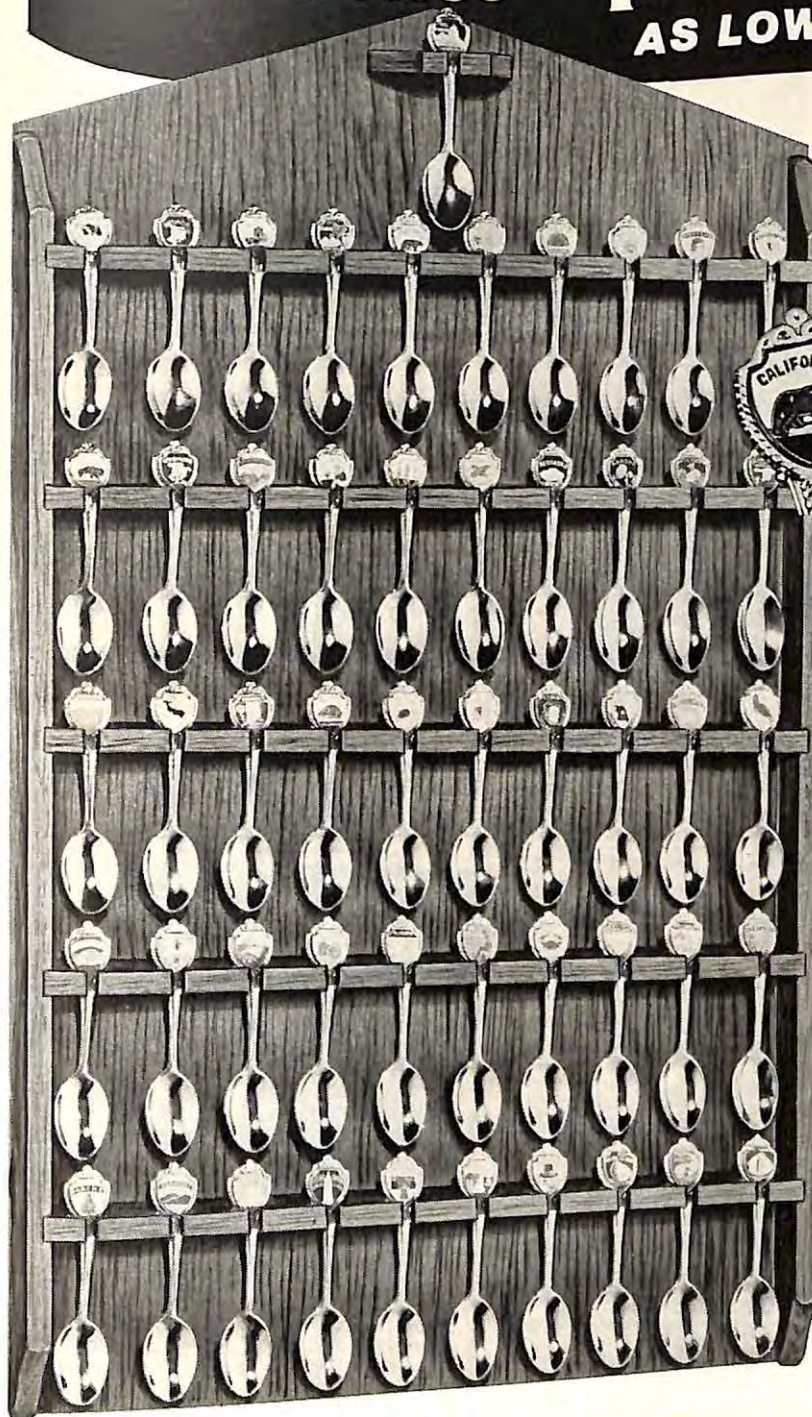

- Real demitasse - size spoons 3 3/8" long
- Brilliant Silvertone finish!
- State Insignia in color in hard-baked enamel!

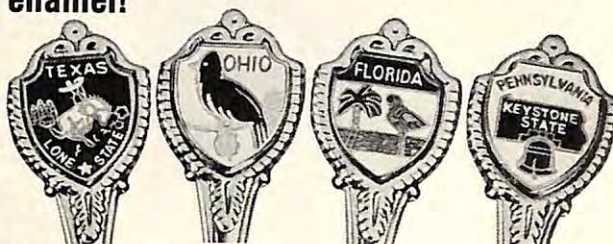

Since the turn of the century, souvenir spoons have been collectors' favorites! In addition to the magnificent display they make, each one is so unique, so individual, so fascinatingly different. Can't you just hear your guests exclaiming as they discover each different state in your display! Imagine the compliments when they admire the entire gleaming collection!

But when they discover how little your magnificent collection cost (if you tell them!) they'll be literally astonished! For never before, we believe, has a Matched Collection like this been offered at such an amazing price. Only \$39.98 postage paid — less than 80¢ each for the entire 50-state collection, with a bonus Washington, D.C. spoon given to you at no extra cost!

**Spoons also Available Separately or by 10-spoon Regional Collections.** Most spoon collections are offered only as complete sets, but if you wish to buy a single state spoon or your choice of several, you may order them for \$2.98 each. Or, you may order 10-state sets for only \$12.98 per set — a savings of over \$16 over purchasing each separately.

**Order risk free now!** When your spoons arrive, inspect them, display them, admire them, show them to your guests. Then if you're not totally delighted, simply return them within 14 days for full refund (except postage and handling, of course). Mail coupon today!



**FREE Bonus Spoon**  
Get "Washington D.C. — The Nation's Capital" spoon worth \$2.98 at no-extra cost when you order Complete 50-state Collection at \$39.98 and we pay the postage!

© 1978 American Consumer, Inc.,  
Caroline Rd., Phila., PA 19176

**HARDWOOD CUSTOM-DESIGNED 51-SPOON DISPLAY CASE AVAILABLE! READY TO HANG — ONLY \$9.98**

**YOUR CHOICE — ONLY \$12.98 PER COLLECTION**

- COLLECTION A — FAR WEST** Alaska Nevada Utah Idaho California  
Hawaii Oregon Arizona Montana Washington
- COLLECTION B — WEST CENTRAL** N. Dakota Wyoming Colorado  
New Mexico Oklahoma S. Dakota  
Nebraska Kansas Texas Minnesota
- COLLECTION C — EAST CENTRAL** Wisconsin Michigan Indiana  
Arkansas Louisiana Iowa Illinois  
Missouri Mississippi Ohio
- COLLECTION D — SOUTHEAST** Virginia Tennessee N. Carolina  
Georgia Alabama West Virginia  
Maryland S. Carolina Florida  
Kentucky
- COLLECTION E — NORTHEAST** Maine Vermont Connecticut  
New York Pennsylvania  
New Hampshire Massachusetts  
Rhode Island New Jersey Delaware
- Spoons for display only — not for culinary use.*

**MAIL NO-RISK COUPON TODAY**

**AMERICAN TREASURY, Dept. SDS-11**  
Caroline Road, Philadelphia PA 19176

Please send me the State Demitasse Spoon Collection order below.

— (#009) Complete 50-State Collection(s) plus Washington, D.C. spoon included as a bonus, for \$39.98 each collection postage paid. (Less than 80¢ per spoon!)

— (#017) 51-spoon custom-designed wood display case(s) at \$9.98 plus \$1 postage & handling each.

10-spoon regional Collection(s) at \$12.98 plus \$2 postage & handling each collection (indicate regions desired below)

— (#033) A  
— (#041) B  
— (#058) C  
— (#066) D  
— (#074) E

— (#108) Individual State Spoon(s) for the following states at \$2.98 plus 30¢ postage & handling each.

If after receiving my order I'm not delighted, I may return it (them) within 14 days and you will refund the full purchase price (except postage handling).

Total amount enclosed \$\_\_\_\_\_ PA residents add 6% sales tax. Check or money order, no CODs please.

**CHARGE IT:** (check one) Exp. Date \_\_\_\_\_  
 Visa/BankAmericard  
 American Express  
 Master Charge  
 Bank Number \_\_\_\_\_

Credit Card # \_\_\_\_\_  
 Name \_\_\_\_\_  
 Address \_\_\_\_\_ Apt. # \_\_\_\_\_  
 City \_\_\_\_\_  
 State \_\_\_\_\_ Zip \_\_\_\_\_

American Treasury is not affiliated with the U.S. Treasury or any other government agency.

8879 Div. of American Consumer, Inc.



# TALL & BIG MEN

• Sleeves to 38" • Shoes to 16EEE

## 5 REASONS TO SHOP

**King-Size**

### 1. PERFECT FIT

— Designed to our exact specifications, our clothes are proportioned to fit with extra length or fullness where needed.

### 2. SELECTION

— We stock more styles in more sizes than in any store. Shirts, Slacks, Shoes, Sweaters, Suits, etc.

### 3. REASONABLE PRICES

— Our clothes may be larger, but our prices aren't higher. We don't think you should pay more to get the sizes you need in styles you want.

### 4. CONVENIENCE

— Send for our FREE Catalog then phone or mail in your order. Charge it to Master Charge, BankAmericard, or American Express.

### 5. MONEY-BACK GUARANTEE

— If you are not satisfied with your order, both Before and After Wearing, return for refund.



## SEND FOR FREE CATALOG

My Telephone Number \_\_\_\_\_ Area \_\_\_\_\_

Height \_\_\_\_\_ Weight \_\_\_\_\_ Shoe Size \_\_\_\_\_

Name \_\_\_\_\_

Address \_\_\_\_\_

City \_\_\_\_\_ State \_\_\_\_\_ Zip \_\_\_\_\_

**King-Size** 1309 King-Size Bldg. Brockton, MA 02402

## At Last! A Full-Feature Workbench at an Affordable Price!



Made in U.S.A.

- Huge 12½ sq. ft. surface area
- Solid rock maple construction (225 lbs!)
- 2 large-capacity vises
- Rugged 2" thick laminated top
- Massive 9" x 18" vise jaw will hold even delicate work
- Adjustable leg levelers adjust workbench to uneven floor surfaces
- Easily disassembles for moving
- Available in kit form, too!
- Optional tool well & tool drawer also available

Until now, quality workbenches have usually been too expensive and too small. This huge, extremely versatile bench is available direct from the factory at an incredibly low price.

Garden Way Research, Dept. 90123W  
Charlotte, Vermont 05445

TO: Garden Way Research, Dept. 90123W  
Charlotte, VT 05445

Please send me your free information about the New Garden Way Home Workbench, including details on the build-it-yourself kits.

Name \_\_\_\_\_

Address \_\_\_\_\_

City \_\_\_\_\_

State \_\_\_\_\_ Zip \_\_\_\_\_



## Cheney. Because Frank really enjoyed his game room.

Frank built his own game room and enjoyed many hours there. But then he was confined to a wheelchair and was unable to use it. Now his Cheney Wheelchair Lift III makes movement up and down the narrow basement stairway safe and easy. For more information on Cheney Wheelchair Lifts, Wheelchair Van Lifts, and Weclator™ stairway elevators, contact your Cheney Representative, or write: The Cheney Company, Dept. EM, 3015 S. 163rd St., New Berlin, WI 53151 (414) 782-1100.

helping people help themselves  
**CHENEY Wheelchair Lifts**

## THIS LOOKS LIKE AN ORDINARY SHOE



## BUT IT ISN'T.

This handsome shoe is one of the famous ELEVATORS®, specially designed to make a man look about TWO INCHES TALLER! The man who wears them knows their amazing secret . . . everyone else only knows how much better he looks. Sold by mail and Guaranteed by the ONLY maker of these remarkable shoes. Send for FREE Catalog, showing the wide style selection of ELEVATORS®.

**RICHLEE Shoe Company**  
519 Lake St., Brockton, Mass. 02403  
Send me FREE catalog of ELEVATORS® shoes, without obligation now or ever.

Name \_\_\_\_\_

Address \_\_\_\_\_

City \_\_\_\_\_ State \_\_\_\_\_ Zip \_\_\_\_\_

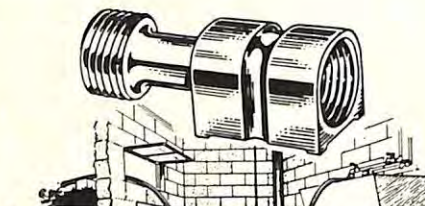

## DRAIN FLOODED CELLAR FAST

Needs No Electric Motor or Gas Engine

To drain out a cellar, pool, vat, cistern, excavation, boat, don't break your back hand-pumping or bailing. Just connect your garden hose to nearby water faucet and free end to intake side of DRAIN-DRI. Connect another length of hose to discharge side, turn on faucet, and normal water pressure makes the Drainer work. This siphon pump has no moving parts to wear, jam or break down. Only \$3.98 plus 80¢ handling and postage. Satisfaction guaranteed or money back.

LARCH, Dpt. 202-C, Box 770 Times Sq. Sta. N.Y. 10036

## GREENHOUSES

from \$88<sup>95</sup>!



Uses up to 40% LESS HEAT!!

All-bolted California Redwood and Fiberglass. Portable. Write to McGREGOR GREENHOUSES, Box 36-3B, Santa Cruz, CA 95063. (408) 476-5390



## 1879 Centennial 100 Year Old Morgan SILVER DOLLAR

This unique and rare Solid Silver Morgan Liberty Head minted in 1879 is extremely popular and certain to increase in value. Packaged and preserved in a plastic container.

Reg. Price \$25.<sup>00</sup> \$17<sup>50</sup>

**SPECIAL OFFER . . . \$17<sup>50</sup>**  
Satisfaction Guaranteed!

All orders add 75¢ for postage and handling.

(Ohio residents add 5.5% Sales Tax).

We accept Master Charge or BankAmericard (Visa).

ORDER FROM DEPT. 679-EM

**WORLD MINT, Inc.**

11725 Royalton Rd. Cleveland, O. 44133

Area Code (216) 237-5446



# EASY-LIFT



## LIKE A HELPING HAND.

Many people—senior citizens, arthritics, and those suffering from Multiple Sclerosis, Muscular Dystrophy or Parkinson's disease—need help getting in and out of a chair. The EASY-LIFT power cushion recliner gently lifts you forward as well as up to a semi-standing position. The lifting angle adjusts to fit your needs, controls are easy to reach, and it runs on household current. EASY-LIFT—like a helping hand.

WRITE FOR FREE BROCHURE  
AND NAME OF DEALER NEAREST YOU.  
**AMERICAN STAIR-GLIDE CORP.**

4001 East 138th Street, Dept. EE-39  
Grandview, Missouri 64030



## Tune your Guitar

like a professional! This new invention is ideal for every guitarist—beginner or accomplished musician. Six precision-tuned reeds make exact tuning, a snap. Just clamp this gadget onto your guitar, then adjust the strings. When the right pitch is reached, the corresponding reed vibrates. Just as simple as that! Ideal for bands or combos. Tunes all instruments to exactly same pitch. Gift boxed. Only \$8.95 plus \$1 shipping and handling. Moneyback guarantee.

ED SALE STUDIO, 893-A, GRAND ISLAND, FLA. 32735

## Select Your LOG HOME



Use your custom plan or select one of ours. Select Cedar or Pine Log homes, leisure homes, and cabins from \$3900. Plan book \$3.50. Dealership Information pack \$6.00.

## Wilderness Log Homes

Rt. 2-ELK39, Plymouth, WI 53073

Please Send  Plan Book \$3.50  
 Dealership Information Pack \$6.00

Enclosed is \$ \_\_\_\_\_

Name \_\_\_\_\_

Street \_\_\_\_\_

Town \_\_\_\_\_

State \_\_\_\_\_ Zip \_\_\_\_\_

## Spectacular "Night-Owl" Glasses Cut The Glare Dramatically...

# Lets you drive thru fog or night and blinding glare with lifesaving visibility and safety!

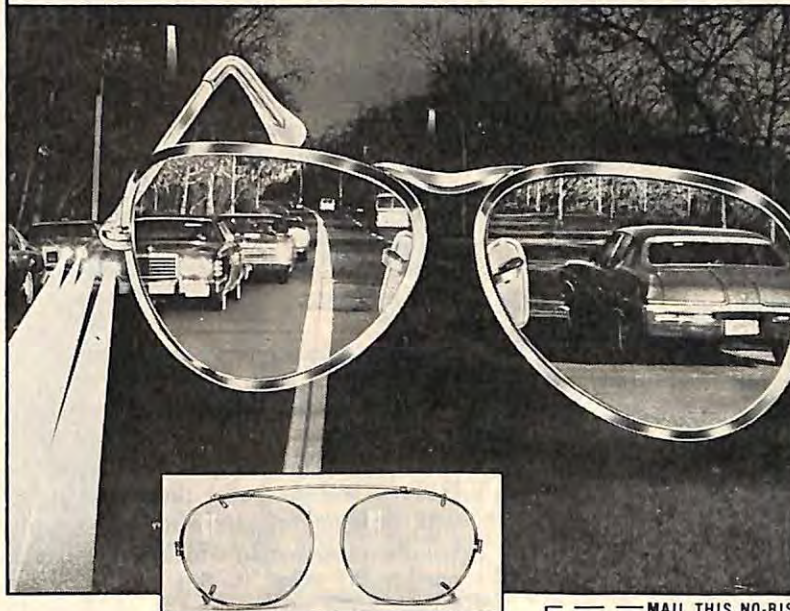

✓ Penetrates dense, hazy fog.

✓ Cuts down oncoming headlight glare.

✓ Reduces blinding glare from reflected summer, winter sun rays and snow.

✓ Prevents eye-strain and fatigue.

✓ Ideal for outdoor sports.

Imagine being able to see clearly through oncoming, dazzling automobile headlight glare while driving on pitchblack highways . . . penetrate dense, misty, hazy fog . . . eliminate glare of blazing sun and glistening, blinding white snow—do all this with no straining, no squinting, no fatigue but with the greatest of driving ease and comfort.

Yes, you can reduce dangerous nighttime headlight glare from oncoming cars . . . your vision can pierce dense, misty fog to detail the road ahead . . . you can improve your night driving vision to that of a night owl with these spectacular, scientifically designed impact resistant glasses.

These remarkable "Night-Owl" glasses are made of special amber-yellow lenses that let through infra-red light, but filter away irritating and blinding ultra-violet rays. Instantly you see more clearly . . . dazzling, blinding headlight glare from oncoming cars look like soft, amber lights . . . objects in a fog-drenched distance take shape, become more clearly defined. You can judge distances better. Snow and scenery will look more spectacular, yet you'll see more clearly and safely without shimmering, blinding effect.

The "Night-Owl" frame is attractively designed for a comfortable fit—one size fits all. Also available in handy clip-on style to fit your regular eye-glasses. Each style comes in attractive vinyl carrying case and is boxed. Your cost for either style, only \$7.95 each. Order several to keep in each of your cars. Satisfaction guaranteed or your purchase price refunded within 14 days (less postage and handling, of course). Order today—NOW!

© 1978 Encore House, Inc., Roberts La., Glen Head, NY 11545

### MAIL THIS NO-RISK COUPON TODAY

ENCORE HOUSE, Dept. NDG-89  
Roberts Lane, Glen Head, New York 11545

YES! Please rush me the "Night-Owl" glasses checked below, so I can enjoy improved visibility while driving at night or in fog.

Check style and indicate quantity desired:  (#110) Regular Frame  (#120) Clip-On Frame

1 pair of "Night-Owl" Driving glasses in vinyl carrying case for \$7.95 plus 75¢ postage & handling.

SAVE \$1.70—2 pair "Night-Owl" Driving glasses in vinyl carrying cases for \$13.95 plus \$1.00 postage & handling.

I understand that if I'm not fully satisfied with my order, I may return it within 14 days for a complete refund of my purchase price (less postage & handling, of course).

Amount enclosed \$ \_\_\_\_\_ (NY residents please add sales tax.) No C.O.D.s please.

CHARGE IT!  VISA (BankAmericard) Exp. Date: \_\_\_\_\_  
 Master Charge

Credit Card # \_\_\_\_\_

Name \_\_\_\_\_

Address \_\_\_\_\_

City \_\_\_\_\_

State \_\_\_\_\_ Zip \_\_\_\_\_



Send for FREE Color Catalogs and Price List

## Save on ACCORDIONS

IMPORTER-TO-YOU SAVINGS

33 Models — Famous Makes Buy direct from importer. Standard or Electronic for students, teachers, professionals. Save middleman profit. 5 Day home trial. Terms. Trade-ins welcomed. Satisfaction assured.



Hohner Button Models. Discount Prices!

Accordion Corp. of America—Dept. E-39  
5535 W. Belmont Ave., Chicago, Ill. 60641

Send FREE CATALOGS and Money Saving Prices on:

Standard and Electronic Accordions  
 Hohner "button" Accordions  Cordovox

Name \_\_\_\_\_

Address \_\_\_\_\_

City \_\_\_\_\_ State \_\_\_\_\_ Zip \_\_\_\_\_

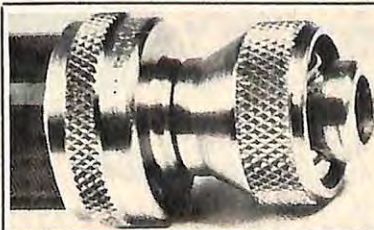

## NEW! Adjust-A-Power Hose Nozzle

has 50% more power and lifetime leakproof guarantee. The ONLY adjustable nozzle with solid jet stream. Precision made of solid brass with stainless steel ball bearings. Easy fingertip control permits adjustable sprays: pin-point, fan spray, solid jet stream, or complete shutoff. No washer needed—ever! Ideal for patio, garden, auto, driveway, or industry. MONEY BACK GUARANTEE. Order direct from LARCH, Dept. 602-A, Box 770 Times Sq. Sta., New York, 10036

**343**  
plus 55¢ shpg. & hdlg.



# New Kinds of Bingo

Add \$\$-use

**• BETTER • FASTER  
• MUCH MORE PROFITABLE!**

Add more money and extra excitement to your fund raising efforts. We've helped thousands of non-profit groups raise sizable amounts of money to continue their good works: Some are making **MORE THAN \$1000.00 PER WEEK** using our innovative money-making games. For the name of the dealer nearest you, fill out the coupon.

## Instant games

1140 N. Kostner Ave.  
Chicago, IL 60651  
Toll Free Call (800) 621-7727  
PLEASE PRINT

Organization \_\_\_\_\_ E

Your name & title \_\_\_\_\_

Telephone (    ) \_\_\_\_\_

Street \_\_\_\_\_ Route \_\_\_\_\_ Box \_\_\_\_\_

City \_\_\_\_\_ State \_\_\_\_\_ Zip \_\_\_\_\_

## THE ORIGINAL BASEMENT TOILET

Genuine Porcelain



FLUSHES UP TO  
SEWER OR SEPTIC TANK

-No Digging Up Floors-  
INSTALLS EASY. ANYWHERE!

Write McPHERSON, Inc., Dept. E  
Box 15133 Tampa, Florida 33684

**VOICELESS THROAT CANCER PATIENTS CAN TALK!**  
Read unsolicited testimonials from LARYNGECTOMEES  
The UNIQUE COOPER-RAND INTRA-ORAL SPEECH AID  
is Recommended by Doctors and Hospitals Nationwide.

**Professional Hearing & Speech Aids Service**  
Qualified for Medicare  
Low Price—Low Upkeep  
(203) 525-2131  
Established 1946

26 Bushnell Plaza, Hartford, Ct.  
06103

## PROSTATE RELIEF

Discomforts due to Benign Prostatic Hypertrophy (BPH), such as getting up nights (nocturia), dribbling, urgency and undue retention are often relieved by PROSTEX. Send for FREE REPORT today. UXBRIDGE CO., Dept. 69, 132 Adams St., Newton, Mass. 02158.

## ELKS EMBLEM BOLO TIE

Handsome gold & black Bolo Tie has gold and porcelain slide with the Elks Emblem & your lodge number in 14 kt. gold. Beautiful gift for yourself, for friends. Fund-raising prices on request! Print lodge number, \$6.95. Without lodge number, \$5.95. Add \$1.00 ship. Send to:



**E. B. CERAMICS**  
R.D. 1, Box 161,  
Old Bridge, N.J. 08857

## JOKES FOR SPEAKERS!

Topical Joke-Bulletin with approx. 100 funny one-liners, stories and roast-lines. Created by top Hollywood comedy writers. Ideal for Business and Club meetings, Banquets, etc. Humorize your speech for any audience; any occasion. Current issue, \$5.00. Send check or m.o. to:

**JOKES UN-LTD.**

1357 Miller Dr. Dept. E-2, Hollywood, Calif. 90069

## Loneliest Man

(Continued from page 34)

that the Western powers would neither interfere nor divert Hitler with an invasion from the West. Hess sat out most of the war as a British prisoner.

In conversations seven years ago with former Lt. Col. Eugene K. Bird, former U.S. commander at Spandau, Hess admitted that he knew of the planning for Operation Barbarossa, the attack on Russia, but did not say if he had told the British about it.

Official Soviet histories claim the "second front" invasion of occupied France by Allied troops was delayed until 1944 after it had become clear that the Soviet army could defeat the Nazis. This deep suspicion has clouded all East-West relations in the postwar era.

While Hess has been described as the "loneliest man in the world," and the "most examined man in history," interest in his case waned until three years ago. Then Speer, who had been Hitler's architect and then director of war production, published his second volume of memoirs, which concentrated on his 20 years in Spandau, and interest grew anew. And it is likely to increase even more after the publication of a new American biography on Hitler.

German interest in Hess is probably less than in surrounding countries and the United States. It is illegal in West Germany to promulgate Nazi propaganda or for a political party to call itself "National Socialist"—Nazi.

The small group of individuals promoting Hess' release call themselves the "Citizens Initiative." The few former party members who hold reunions to wallow in the glory of the old Nazi days are mostly elderly pensioners with little following. While other middle-aged Germans harbor nostalgic feelings for the old days, they rarely express themselves publicly about such sensitive issues as the confinement of Hess. Two neo-Nazi agitators, Manfred Roeder and Otmar Ganz, were arrested outside Spandau four years ago for distributing leaflets claiming Hess was being harassed to death. They were fined \$1,200.

So it appears that the No. 2 man of Nazi Germany will die in Spandau Prison. But Rudolf Hess doesn't think so.

In a recent letter to his wife he wrote: "I would never again put a bird in a cage. Only now do I fully understand why the Chinese and Japanese, when fate is especially kind to them, go to the market, buy a bird, open the door of the cage and let it fly away. One day I will do this too."



## SAVE HUNDREDS OF DOLLARS

Possess the gem that's as brilliant as a diamond.

The incredible MAGIC FIRE™ has more "fire" than a glittering natural diamond. Own the dazzling impact of diamonds that can easily sell for up to \$1,000 per carat — for a fraction of the cost. From \$35 — All settings in 14K Solid Gold. Send for our FREE catalog of pendants, earrings, and rings for men and women. Credit cards accepted.

## MONEY BACK GUARANTEE

Easy Payment Plan Available

**The Crown Collection** Dept. EL-93  
509 Madison Ave, NY, NY 10022

## PROTECT YOUR VALUABLES



Avoid losses. Protect valuables and records from burglary or fire with a SECURITY CUBE. Furniture cabinet conceals a steel safe. Looks like an end table. Combination lock prevents entry. U.L. Labs. fire tested. Model Q-7 only \$164.95. FREE DELIVERY. Send for FREE CATALOG.

THE J. GOODMAN CO., Dept. EL-4  
BOX 88, LIVINGSTON, N.J. 07039

## WIN BIG OIL MONEY PLUS TAX BENEFITS

The U.S. Government each month sponsors a little-known oil lease drawing. If you are 21 and a citizen you can compete with the oil companies for this federal land. A \$25. (Tax Deductible) fee can bring you as much as \$75,000 immediately plus future payments. Write Dept. 7 or call toll free 1 (800) 528-6050, Ext. 321. In Arizona 1 (800) 352-0458.

F. MILLIGAN, INC. Drawer 3408, Boulder, CO 80307

## HEARING AIDS

**SUPER SAVINGS!** Newest, Finest. All types. Buy DIRECT & save up to HALF! No salesmen. Sold by AIR MAIL on HOME TRIAL. FREE Catalog. Write: **MONEYSAVERS** Dept. EK-3, 9530 Langdon Ave., Sepulveda, Cal. 91343

SAVE 1/2!

FREE CATALOG — WRITE!

## Japanese Swords Wanted by Collector

**George Nalle**

203 Colorado Street

Austin, Texas 78701 (512) 477-6168

REMBRANDT DID IT IN OILS...

Let us do it in  
**BRONZE PLAQUES**  
FOR ALL OCCASIONS

Write for Free Catalog E23  
Engraved Plaques E21

INTERNATIONAL BRONZE TABLET CO., INC.  
150 W. 22nd St., N.Y., N.Y. 10011 212-WA 4-2323







For **EVEN FASTER SERVICE**  
Credit Card Holders  
may call  
**TOLL-FREE**  
**800-257-7850**  
in N.J. 1-800-322-8650  
24 hours a day,  
every day —  
even Sunday!

**Toll-Free**

**VISA**

**master charge**

# COUNTRY CLUB SLACKS

with the **INDELIBLE CREASE!**

Webster says, "Indelible — cannot be removed or washed away."

Yes! The straightest, most permanent NO IRON CREASE you have ever known, ingeniously stitched into the very weave of these deluxe Country Club Slacks, for real

"LIFE-OF-THE-PANTS" GOOD LOOKS

**2** pairs for only **24<sup>95</sup>**

including the **MINUTE-to-MINUTE GIVE AND TAKE WAIST!**

Yes! You have seen these improvements in the \$30 racks in Country Club Pro Shops. Ditto your better Dept. Stores! Now here comes Haband, the mail order people from Paterson, N.J.. with a better offer: Slacks with the Indelible Crease, now with Built-In Flexible Waistband! You get better than 2½ inches of built-in, all-around stretch, so they fit to perfection every minute of the day! Sitting, standing, driving behind the wheel, you get easy, gentle adjustment to your moving shape & posture.

- Hook Top Closure
- Deep long-wearing "No-Hole" Pockets!
- Stylish new Modified Flare Leg!
- And Yes, of course —
- 100% NO IRON Automatic Wash & Wear, 100% Polyester Knits for Extra Long Wear!

Send for 2 Pairs!

You'll save on initial price, save money too on Cleaner's Bills, while enjoying these latest and handsomest

gentlemen's dress-up slacks. We will be proud to send you any 2 pairs for your on-approval at-home inspection. Just check your choice on the coupon below.



See Yourself in the 1979 Vacation COLOR of the YEAR Soft LIGHT GREEN

Haband's 100% polyester  
**NO IRON SLACKS** with the **INDELIBLE CREASE**  
**2** pairs for **24<sup>95</sup>**  
3 for 37.20 4 for 49.50

**HABAND COMPANY**  
265 North 9th Street  
Paterson, N.J. 07530

**ALL THESE SIZES IN STOCK:**

Waists 29-30-31-32-33-34-35-36-37-38-39-40-41-42-43-44-46\*-48\*-50\*-52\*-54\* (\*Add \$1 per pair)  
Inseams 26-27-28-29-30-31-32-33-34

Gentlemen: Please send me \_\_\_\_\_ pairs, for which I enclose \$ \_\_\_\_\_ plus \$1.25 toward shipping.

**NO RISK GUARANTEE:**  
If on receipt I do not want to wear them, I may return the slacks within 30 days for full refund of my remittance.

To Charge Your Order:

VISA } Acct #  
 Master Charge }  
72L-018

COLOR	Waist	Inseam
Lt. BLUE		
BROWN		
GREY		
Champagne		
Lt. GREEN		

Name \_\_\_\_\_ Apt. # \_\_\_\_\_  
Street \_\_\_\_\_  
City & State \_\_\_\_\_ Zip \_\_\_\_\_

Haband, a conscientious family business operating by U.S. Mail since 1925. Fast, reliable service.

**HABAND**  
265 North 9th Street  
Paterson, New Jersey



# The Crowning Touch

Seagram's 7 "crowns" any drink with great taste because it tastes better all by itself. On the rocks, or with soda—in the classic Manhattan or whiskey sour—there's just nothing better. And enjoy our quality in moderation.

**Seagram's 7 Crown**  
Where quality drinks begin.

