

the
Elks
magazine
AUGUST 1978

The Weather-
We're Doing Something
Frontier Photographer-
William Jackson
Digest of Annual Reports

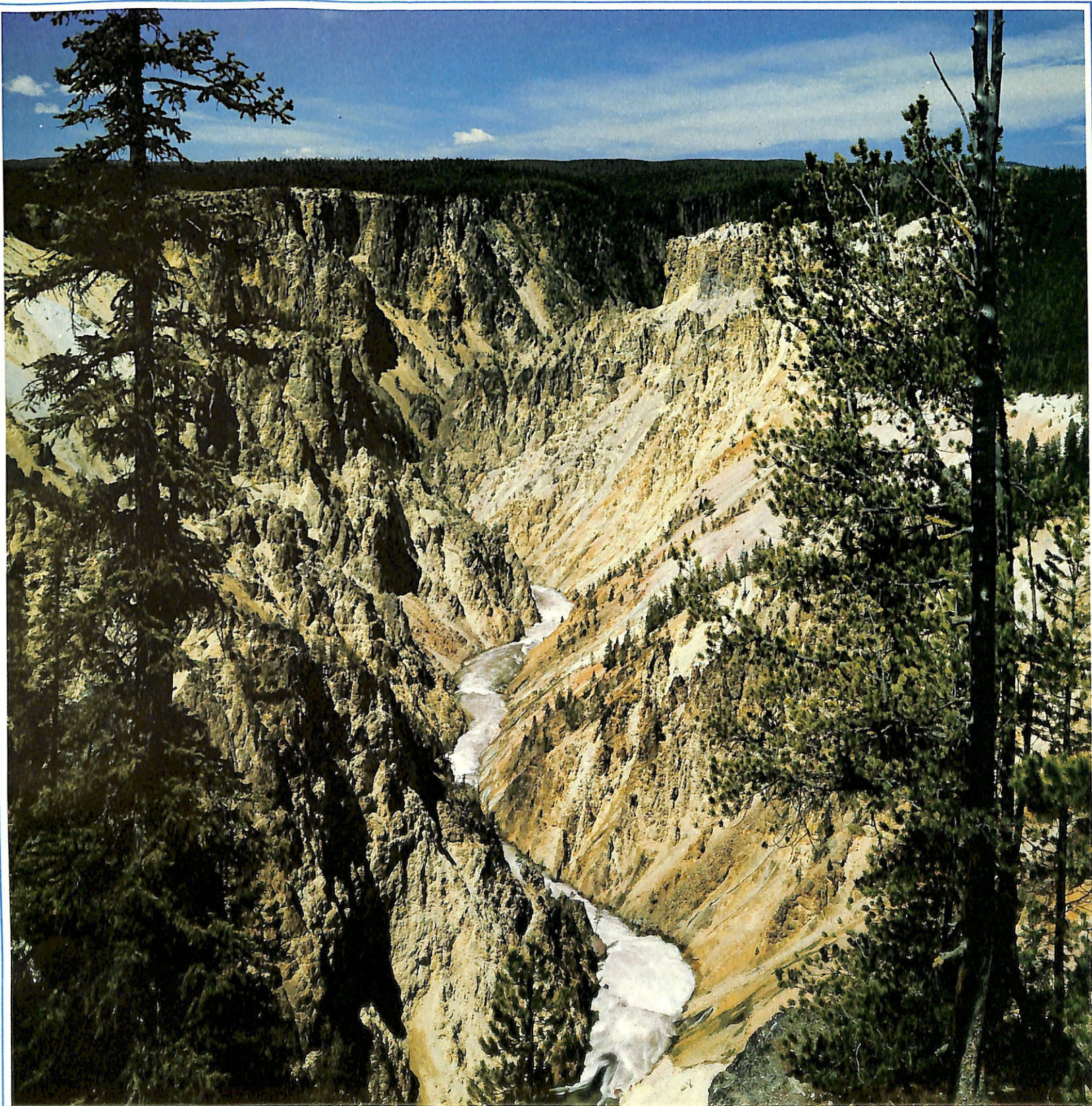



Executive Fashion SLACKS for the
SENIOR MAN®
2 PAIRS OF SLACKS for only **19⁹⁵**

WHO IS the Senior Man around here?

One look and you know who is in charge. He is the Top Man at the office, or the senior Partner, or the Head of the Household. And he dresses the part! His requirements in clothing are simply not the same as the Junior Executive or the Disco Dancer.

He's in GOOD PHYSICAL SHAPE, but LET'S FACE IT:

Today's tight bottomed pants with string bean legs will never fit the man over 40! But that doesn't mean he's an old-age dropout! Now Haband, the mail order people from Paterson, N.J., have put a new emphasis on slacks with **LEADERSHIP STYLING: The new, more fashionable look but with roomier cut!** Your exact size, now in your proper proportions!

You get excellent fabrics, and the distinctive 1978 styling, and at

NO SACRIFICE of COMFORT or QUALITY.

2 PAIRS for 19.95 — But it's not the price, IT'S THE FIT!

"Here comes the boss!"

Rest assured, they know!

NO IRONING!

We are talking about today's newest business fabrics, 100% texturized polyester with new "Naturalized" soft hand, beautiful drape, and the latest most improved **100% NO IRON WASH & WEAR PERFORMANCE.** Tailored with countless executive refinements such as non-slip, no-roll inner waistband, deep no-hole pockets, good wide belt loops, Talon® unbreakable zipper, the Works! Plus the top 1978 headline style in a cut that **FITS** the Senior Man! **Remember:** Business Slacks are Haband's Business! There's no need to pay more expensive prices when you can order conveniently right now with this coupon — **TRY THEM ON, at NO RISK!**

The new **Mature Cut** that makes you **LOOK YOUNGER** (Because they Fit Better) **SEE FOR YOURSELF**

Over 2-million executives, from all over America, depend on Haband for all their clothing needs! Sooner or later you too will discover that our new approach will suit you better and save you money as well. So why miss out now?

We will be proud to send you any **TWO PAIRS** for your private **AT HOME INSPECTION.** Try them on, show your wife and family, and then decide. To order, simply tell us your size and choice of colors on this easy order form. Then watch our fast reliable service. *Just say the word!*

HABAND DIRECT MAIL ORDER HOUSE

265 North 9th Street, Paterson, New Jersey 07530
A conscientious family business, established in 1925.

SENIOR MAN® **2** pairs for only **19⁹⁵** 3 for 29.85
Executive Dress Slacks 4 for 39.70 All 5 pairs for 49.50

HABAND COMPANY, Special Service Dept.
 265 North 9th St., Paterson, N.J. 07530

OK, Haband! I want to try pairs of your new Executive Cut **SENIOR MAN** Slacks. My size and color choices are at right and I enclose my remittance of \$

GUARANTEE: If upon receipt I do not choose to wear the slacks, I may return them within 30 days for full refund of every penny I paid you.

72B-068
 Name Apt. #
 Street
 City
 State ZIP CODE [][][][][][]
 We promise **FAST RELIABLE SERVICE**

FIND YOUR WAIST & INSEAM

Waist 29-30-31-32-33-34-35-36-37-38-39-40-41-42-43-44-45-46-47-48-49-50-51-52-53-54.
 Inseams 26-27-28-29-30-31-32-33-34.

COLOR	How Many	Waist	Inseam
BLUE			
BROWN			
GREY			
Forest GREEN			
BURGUNDY			

*"In the continual remembrance of a
glorious past individuals and nations
find their noblest inspiration."*

SIR WILLIAM OSLER

NOBLEST INSPIRATION



A
MESSAGE
FROM THE
GRAND
EXALTED RULER

THE NEW GRAND LODGE OFFICERS whom you so magnanimously selected for the coming year pledge their every *effort* and *enthusiasm* to rekindle a glow of the inspirational accomplishments of the past. We appreciate the honor bestowed upon us; we are determined to do everything to justify your confidence in us, and we promise our continued best effort and dedication to the interests of the Order. At this time it is incumbent upon us to recognize and thank Past Grand Exalted Ruler Homer Huhn, Jr., and his committeemen for their fine example of such unflinching effort and complete dedication.

OUR ORDER has achieved renown and national respect by fulfilling the visions of our predecessors who knew that success is the result of constant and continued hard work. Their aggressive leadership, their unselfish and arduous work did, indeed, lead to the universal recognition which our Order now enjoys. We, their successors, must be imbued with these same qualities, these same virtues, if you will, if we are to continue the remarkable work already in progress. An enthusiastic approach to the Grand Lodge Program is mandatory to maintain our present standard of excellence.

LET US LOOK proudly to the past for the inspiration that will strengthen us to face and solve the taxing problems which await us. This is an intelligent and logical approach to success "... building on the solid foundations of the past to meet the challenges of the present and prepare for the future."

THE JOY of anticipation and hope of achievement stimulate and inspire your new officers. In preparing to implement this year's Grand Lodge Program it is apparent that, since we shall be ascending from high ground, if further progress is to be achieved each of us must pledge himself to **Continued Commitment To Effort and Enthusiasm.**

Leonard J. Bristol

Dr. Leonard J. Bristol

ARIZONA DOUBLE FEATURE

Available on loan FREE
Except return postage of \$1.82 in the U.S.

The Story of ARIZONA and SUN CITY

Narrated by Senator Barry Goldwater

Captures the beautiful diversity of the Grand Canyon State, tracing the Arizona Story from the invasion of Conquistadors to the rise of Sun City. (16 mm, 30 min)

■ A profile of a community that changed the definition of retirement, earning a place high on the list of attractions that draw visitors (and new residents) from the world over to Arizona. (16 mm, 25 min)



Sun City

America's Most Famous Resort-Retirement Community

MAIL 3 WEEKS AHEAD TO RESERVE FILMS

DEL E. WEBB DEVELOPMENT CO. DEPT. EM-88M
P.O. BOX 1725, SUN CITY, ARIZONA 85372

Name _____
Address _____
City _____ State _____ Zip _____
Date of showing _____ Organization _____

*Reservations subject to film availability

Del Webb's Sun City is NOT a lot sales development

Del E. Webb Dev. Co. • 17400 N. Del Webb Blvd. • Sun City, AZ 85351

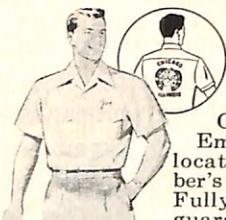

PERSONALIZED BOWLING SHIRTS

Complete with Elks Emblem, lodge name and location on back; member's name above pocket. Fully washable . . . fully guaranteed! Min. 4 shirts.

Permanent Press Double Knit \$16.95*
Permanent Press Kodell & Cotton \$14.95*
Sturdy, Lightweight Chadel \$12.95*
F.O.B. Chicago Write for complete information

To serve you better, we have moved to larger, more modern quarters.

RH **RUSSELL-HAMPTON CO.**
Dept. E, 2550 Wisconsin Avenue
Downers Grove, Illinois 60515
(A Chicago Suburb)

BINGO

Largest Manufacturer
and Distributor of
BINGO Supplies

Free Catalogues available for:

- ★ Complete bingo supplies
- ★ Tables & chairs
- ★ Flags & banners
- ★ Armchair races
- ★ Jar & breakopen tickets

ALL STAR BINGO INC. Dept. E-8
P.O. Box 940, Arverne, N.Y. 11692
Toll Free Call: 800-221-6706



the Elks magazine

VOL. 57, NO. 3 / AUGUST, 1978

NATIONAL PUBLICATION OF THE BENEVOLENT AND PROTECTIVE ORDER OF ELKS OF THE UNITED STATES OF AMERICA. PUBLISHED UNDER THE DIRECTION OF THE GRAND LODGE BY THE NATIONAL MEMORIAL AND PUBLICATION COMMISSION.

THE ELKS NATIONAL MEMORIAL AND PUBLICATION COMMISSION

WADE H. KEPNER/Chairman
R. LEONARD BUSH/Vice-Chairman
RAYMOND C. DOBSON/Secretary
EDWARD W. McCABE/Treasurer
ROBERT E. BONEY/Asst. Secretary and Asst. Treasurer

JOHN R. RYAN/Publisher/General Manager
JEFFREY BALL/Managing Editor
MARY M. CAVANAGH/Fraternal News Editor
MALCOLM B. CROFFORD/Circulation Manager
EDITORIAL OFFICES, 425 W. Diversey Parkway, Chicago, IL 60614

- 4 **We're Doing Something About the Weather** Richard Wolkomir
Step by faltering step man is learning to do something about the weather.
- 10 **Frontier Photographer** Richard Grant
William Henry Jackson carried his equipment on a mule—and helped open the West.
- 21 **Telephone Teaching** Bill Thomas
Teaching Johnny to read is important work. But, what if Johnny's parents can't read either?

Departments

- | | |
|---|-------------------------------------|
| 1 Message | 23 It's Your Business: Reflections |
| 8 You and Retirement: No Retirement? | 24 Travel: Riviera |
| 14 Medicine and You: Vitamins | 26 Elks National Service Commission |
| 15 News of the Lodges | 27 News of the State Associations |
| 20 Visits of Homer Huhn, Jr. | 29 Digest of Annual Reports |
| 22 Elks National Foundation/
Joy of Giving | 36 Elks Family Shopper |

Cover: Yellowstone National Park George J. Schwartz
Grand Canyon of the Yellowstone River,
Yellowstone National Park, Wyoming.

ADVERTISING OFFICES



CHICAGO 60614 425 W. Diversey Parkway (312) 528-4500
NEW YORK 10017 50 East 42nd (212) 682-2810

THE ELKS MAGAZINE, Circulation Dept., 425 Diversey Parkway, Chicago, IL 60614

MEMBERS: Changes of address should be made through your lodge Secretary. Give him advance notice of at least 30 days. Remember that the day you write, your next copy is already in the mails. Before you move, file your new address at the post office to have mail forwarded. In writing to us regarding an address change, please give: Full name, lodge number, membership number, address to which copy is being mailed, and complete new address. Attach label from recent issue if available. Please show ZIP Code numbers in both old and new address.

THE ELKS MAGAZINE, Volume 57, No. 3, August, 1978. Published monthly at 425 W. Diversey Pkwy., Chicago, IL 60614 by the Benevolent and Protective Order of Elks of the United States of America. Second class postage paid at Chicago, IL, and at additional mailing office. Acceptance for mailing at special rate of postage provided for in Section 1103, Act of October 3, 1917, authorized May 20, 1922. Single copy price 25 cents. Subscription price in the United States and its Possessions, for Elks, \$1.25 a year, for non-Elks, \$2.50 a year; for Canadian and Foreign postage, add \$1.50 a year. Subscriptions are payable in advance. Manuscripts must be typewritten and accompanied by sufficient postage for their return via first class mail. They will be handled with care but this magazine assumes no responsibility for their safety.

The word, Elks, is a registered trademark of The Benevolent and Protective Order of Elks of the United States of America. Copyright, 1978, by the Benevolent and Protective Order of Elks of the United States of America



454

MUSEUM-MOUNTED TREASURIES OF RARE U.S. COINS THIRTY-DAY "IN-HOME" EXAMINATION

EXCITING WAY TO "SAVE" MONEY!
HANDSOME WALL DISPLAY! PERFECT GIFT!

Please act quickly! Quantities available are strictly limited.

Invest now in America's Treasury! Here's your golden opportunity to own and display three magnificent and increasingly rare collections of historic U.S. coins painstakingly assembled by the Kennedy Mint. Each collection separately mounted and framed in walnut-finished wood, with specially commissioned art by the Kennedy Mint and full description. Attention-compelling display you'll be proud to have on your office, den or living room wall. Ideal as gifts for all occasions and all ages. Use reservation form below to order.

Your warranty: The Kennedy Mint 30-day Home Examination Policy. We will refund your full purchase price within 30 days of shipment if you are dissatisfied with your coins in any way. Exciting family treasuries or memorable gifts. **You may charge these America's Treasury coin collections to your American Express, Diners Club, Master Charge or BankAmericard (VISA) account, if you wish. Charge or cash, you're protected by the Kennedy Mint's 30-day in-home examination policy.**

THE SILVER STORY

The Age of Silver has ended in American coinage. Virtually all silver coins are collectors items since the U.S. switched to "clad" coins in 1964. The collection contains a capsule of pure silver granules once mined from our great deposits in Colorado, Nevada and California, plus WWII silver nickels (1942-1945) along with pre 1964 dime, quarter and half dollar all containing 90% fine silver. Included in this collection is a genuine dollar silver certificate once redeemable for raw silver, now completely gone from circulation. Only \$29.95 plus \$2 shipping and handling. Actual size 12" x 10".

WARTIME COINAGE

Victory under the moral and distinguished leadership of President Roosevelt and General Eisenhower was ours. Both of these leaders have been enshrined forever in U.S. Coins and are featured along with J.F.K. half dollar. During WWII the U.S. Mint diverted valuable metals much needed for the war effort. These coins are included:

*Silver Nickles (1942-45) which released stock piles of raw silver.

*The Steel Penny (1943) reduced the demand for copper.

*Lincoln Cents (1944-45) utilized the salvaged shell cases.

A most handsome and distinguished collection. Only \$19.95 plus \$2.00 shipping and handling.

SPECIAL BONUS! LINCOLN MEMORIAL COLLECTION

Special Bonus! When you place your order for both collections, you will receive at no additional cost the Lincoln Memorial Collection. The collection contains 29 uncirculated pennies including the original wheat line design (1909-1958). A very difficult collection to assemble, especially such sparkling specimens. Mounted and framed in matching frame—a full \$14.95 value! Actual size 12" x 10".



YES! Please send me the America's Treasury coin collections at right at prices indicated. I enclose my check or money order payable to "Kennedy Mint". I understand if I am not completely satisfied with the collection I may return for full refund within 30 days.

THE KENNEDY MINT

1 Kennedy Circle, Cleveland, Ohio 44142

Set #3189 Both collections at \$49.90 plus \$4.33 postage & handling.

SPECIAL BONUS: Lincoln Memorial.

Set # 116 Silver Story—\$29.95 plus \$2.45 shipping & handling.

Set #3188 Wartime Coinage—\$19.95 plus \$2.45 shipping & handling.

Please charge to my: American Express
 Master Charge Carte Blanche
 Diners Club BankAmericard (VISA)

Account #

Exp.

Credit card users

speed delivery

by phoning 24 hours

toll free: 800-621-8318

In Ill., call 800-972-8308

Sorry, no C.O.D.'s

Name

(Please Print)

Address

City

State

Zip

Signature



On August 18, 1969, a squadron of Navy planes flew out from the Florida coast, climbing above Hurricane Debbie as she lashed the Atlantic. They opened their belly hatches: crystals showered down on the dark clouds.

Soon, the winds slackened. Man had tamed a hurricane.

Since then, weather control scientists have been sharpening their skills, learning to make rain and snow, avert storms, dissipate hail, clear fog, check lightning. They have even used weather in war, as a weapon.

On March 20, 1974, at a top-secret hearing of the Senate Foreign Relations Subcommittee on Oceans and the International Environment, spokesmen for the Joint Chiefs of Staff reported that from 1967-72 U.S. planes flew 2,602 weather missions in Southeast Asia. They had bombarded clouds over North Vietnam, South Vietnam, Cambodia, and Laos with a total of 47,409 canisters of rain-inducing silver iodide and lead iodide.

Results? According to the Pentagon, the \$3.6-million-per-year program to bog down enemy troops increased rainfall in target areas "up to 30 percent above that predicted for the existing conditions."

Civilian rainmakers have done even better. Recently, the National Oceanic and Atmospheric Administration (NOAA) released analyses of 1976 experiments in Florida: cloud seeding had increased rainfall up to 70 percent.

We're Doing Something About The Weather

by Richard Wolkomir

Early rainmaking efforts were chancier. Typical was an 1894 attempt by drought-stricken residents of O'Neill, NE, to "boom" rain from clouds by exploding a ton of dynamite—"They failed to fetch a drop," lamented the local newspaper.

Today, weather modification planes frequently flit over the Great Plains and the western states, twin-engine puddle-hoppers with silver iodide flares mounted under their wings like war-planes' rockets. Directed to "pregnant" clouds by radar and computer, the pilots shoot off their flares. And as the crystals sink through the clouds, a waterdrop condenses on each, just as raindrops ordinarily condense around dust particles. Results can be impressive.

For instance, in 1971, when Altus, Oklahoma, farmers hired a weather modification company to seed clouds during a drought, the clouds poured out 10 inches of rain, nearly half the precipitation the area usually receives in an entire year. Wheat and cotton crops were saved.

South Dakota School of Mines and Technology studies indicate that cloud seeding upped rainfall in tested areas by 10-20 percent annually, while reducing hail 40-60 percent. Over one year, in terms of crops saved, that equals \$30 million in extra income for South Dakota farmers. NOAA cloud seeding increased rainfall 15-20 percent in California's Sierra Nevada mountains.

According to Senator Henry Bellmon,

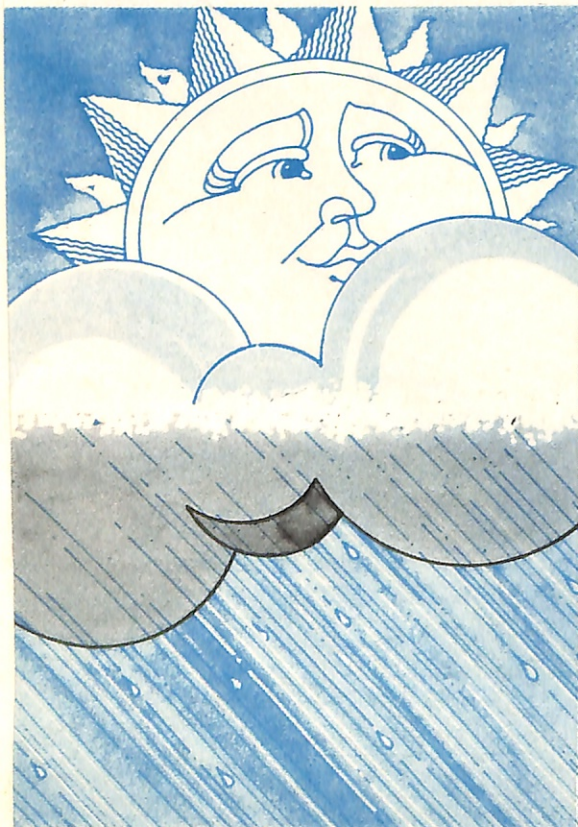

Rain Making

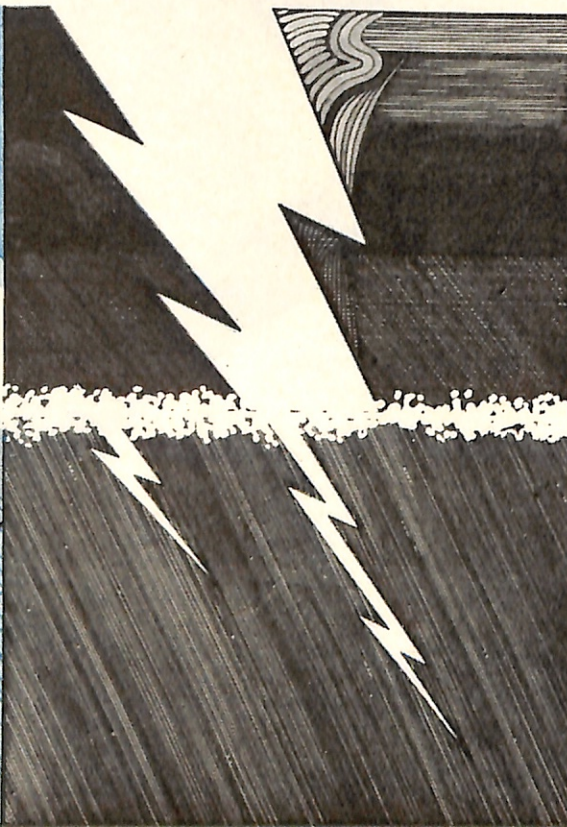

Defang Lightning

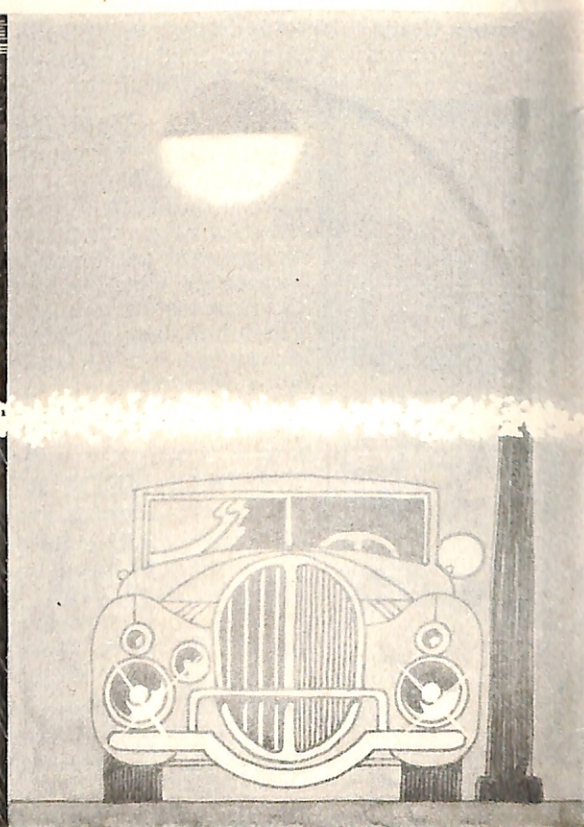

Disperse Fog

of Oklahoma, who seeks a federal weather modification program for agricultural regions, 11 years of cloud seeding in South Dakota have upped rainfall significantly, while Oklahoma's \$250,000 cloud-seeding programs have saved crops valued at 20 times that cost. In the past 10 years, weather modification for U.S. farmers, resort owners, and power companies has become a multi-million dollar business.

Meanwhile, one of man's ancient enemies—lightning—may soon be defanged. Directed by Dr. Heinz Kasevir, researchers at the Atmospheric Physics and Chemistry Laboratory in Boulder, CO, have been seeding electrical storms with aluminum-coated nylon chaff, which discharges the storm's electricity before it becomes lightning. Dr. Kasevir has reported consistent success.

Another old enemy, hail, annually in the U.S. destroys crops valued at \$100-million. But scientists have found that by seeding clouds with millions of artificial nuclei, crystals of silver iodide and other chemicals, they can increase the number of hailstones that form in the clouds. And since the amount of water vapor in the clouds is fixed, the more hailstones that form, the smaller each hailstone is. The goal is to make each stone so small that it melts before reaching the ground.

Soviet scientists report that, by firing silver iodide at clouds with artillery cannons, they have reduced hail dam-

age more than 75 percent in the Ukraine. Currently, they say, over six-million acres of croplands are protected.

Fog, that menace to highways and airports, may soon jump to man's command. In fact, many airports now routinely disperse "cold" fogs (which form when temperatures are below freezing) by dropping dry ice shavings from airplanes or spraying the fog with liquid propane from the ground: the super-cold chemicals freeze the fog's water droplets into ice crystals, which then drift to the ground.

Weather control may soon become a worldwide reality . . .

Warm fogs are tougher to disperse, but tests have shown that heating the air can do the job. For instance, at Paris's Orly Field, technicians have buried jet engines along the main runway. According to airport officials, fired up, the engines successfully burn away fog.

Most dramatic of all weather control efforts is the attempt to tame hurricanes. For the vast storms are awesome foes.

As much as 600 miles across, a hurricane can produce gusts up to 200 mph. Every year one, two, or three hit the U.S., and while improved warning systems have reduced the death toll—in this country, at least—increased shoreline development has considerably upped the economic loss.

For instance, Hurricane Betsy in 1965 and Hurricane Camille in 1968 cost over \$1.4-billion each. Betsy killed 75 people, Camille 268. In 1972, Agnes claimed 118 lives and over \$3 billion in damages. A 1970 hurricane killed 300,000 people in Pakistan. And on Christmas Day, 1974, a hurricane virtually blew the city of Darwin, Australia, off the map.

Hurricane Fifi roared into Honduras on September 18, 1974, slamming the little Central American nation for two days with 100 mph winds and torrential waves, then blowing away up the coast. Fifi destroyed 85 percent of the country's economic base, banana plantations. She killed 5000 people, left 300,000 homeless, flattened entire villages.

Bodies lay everywhere. Bridges, roads, airstrips, and rail lines were in ruins. Wriggling among the survivors, as they waded through mud and flood waters, were thousands of displaced venomous snakes. Homeless, their water supplies contaminated, the refugees huddled hopelessly in makeshift camps. It was like the aftermath of a war.

Hoping to avert such destruction, scientists are experimenting with hurri-

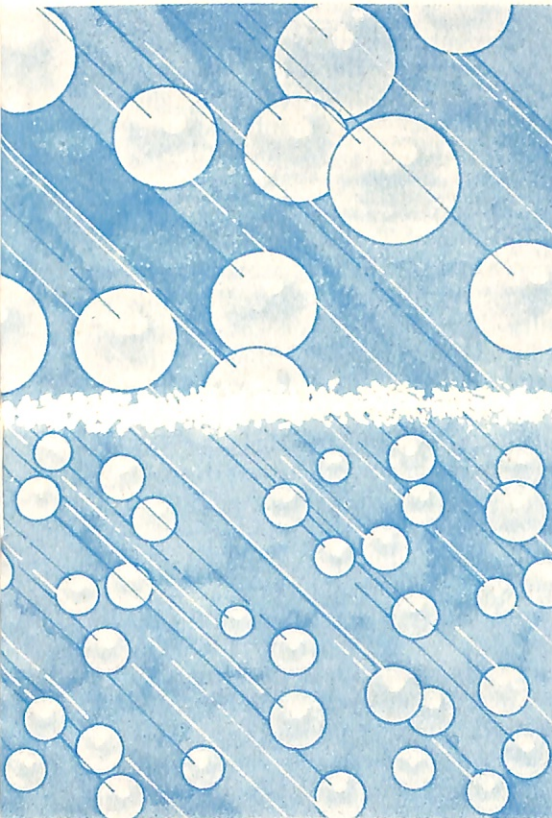

Decrease Hail



Tame Hurricanes

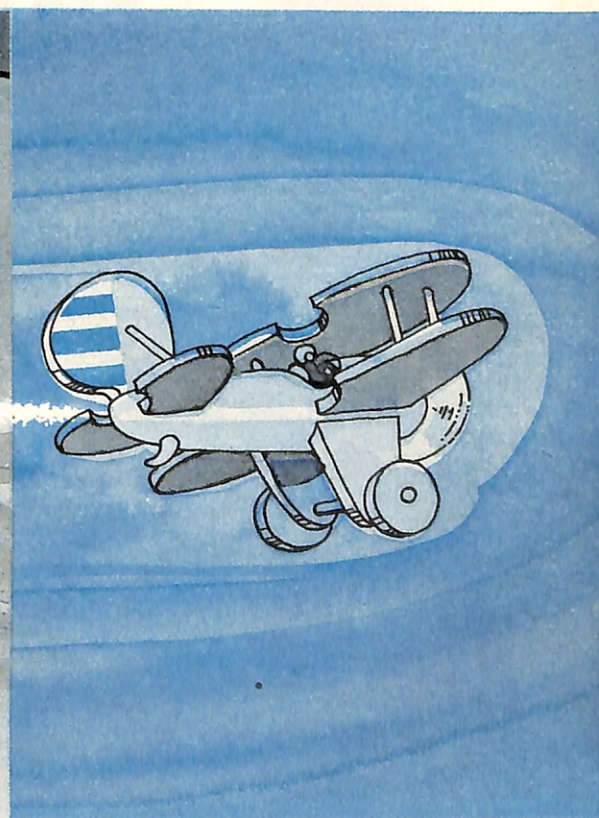

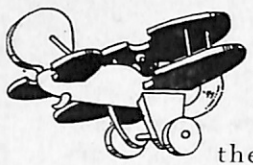

cane control. The secret, they believe, is the storm's structure.

A hurricane's hub is the miles-wide "eye," where the air is calm, the sky blue. Surrounding the eye are towering "eye-wall" clouds that rise like cliffs from bases 500 feet above the heaving sea to rims 50,000 feet up. Spiraling in toward the low-pressure eye from the high-pressure areas beyond the eye-wall clouds are "rainbands"—lines of high clouds releasing torrential downpours.

Born over warm, tropical seas, a hurricane feeds on heat. The storm sucks up warm, moist air near the sea's surface, then swirls the air upwards to lofty heights. As the air rises through the eye-wall clouds and cools, its vapor condenses into water droplets, releasing latent heat that fuels the hurricane with phenomenal energy. In one day a medium-sized hurricane can release as much energy as four-hundred 20-megaton hydrogen bombs.

Some scientists advocate reducing evaporation from the sea's surface beneath a hurricane, thus denying water vapor to the storm. Others suggest cooling the water or the air.

But the most promising tactic is seeding the eye-wall clouds with silver iodide crystals. Scientists of the U.S. government's hurricane control research

team, Project Stormfury, believe the crystals allow the clouds' water vapor to rapidly condense into droplets, suddenly releasing heat. That surge of heat, they theorize, alters the hurricane's pressure distribution, slackening the winds.

When Stormfury planes seeded Hurricane Debbie in 1969, winds dropped 31 percent after the first seeding session, 15 percent after the second. Weather control, still an infant science, has left the realm of science fiction.

For instance, in 1977 alone, the federal government spent about \$15-million on weather modification research. A number of states have their own weather modification programs. Meanwhile, private rain-making companies made approximately \$10 million in 1977, producing rain for farmers, snow for ski resorts, and increasing mountain snowpacks for power companies, so that spring runoffs will be ample for hydroelectric plants.

Nor is the U.S. alone in meteorological engineering. Australia, Brazil, India, Israel, Japan, Kenya, Mexico, the Philippines, and Tasmania are all studying cloud seeding. Canada is investigating electrical fog dispersal. Italy, Japan, France and Canada are studying hail suppression. And the Soviet Union operates a broad range of weather-control projects.

A pet Soviet idea is melting the Arctic icecap to warm the northern hemisphere. Coating the ice with black soot so that it absorbs more solar radiation should work.

Dr. Charles L. Hosler, dean of the College of Earth and Mineral Sciences at Pennsylvania State University, predicted not long ago that satellite mapping of such atmospheric components as vapor, temperature, and winds will greatly advance man's understanding of the forces controlling weather.

"There is little doubt in my mind that in the next century weather and climatic control will constitute an important engineering field," he says.

But many experts question whether we really should open what could be a Pandora's box. As Dr. William A. Nierenberg, chairman of the National Advisory Committee on Oceans and Atmosphere, has warned Congress:

"Technical and scientific developments have progressed to the point where non-scientific questions of societal, economic, and political impact of weather modification operations are now in urgent need of answers."

Take another look at hurricane control. Many meteorologists believe that hurricanes balance global weather by shunting excess heat away from the equator. They worry: if we stifle hurricanes, will the equatorial heat belt and the icy polar caps expand into the temperate zones? Other scientists speculate that suppressing natural hurricanes could generate super hurricanes. All we know for sure is that we know pitifully little about the atmospheric forces we seek to control.

At a recent convention of the American Association for the Advancement of Science, four leading scientists discussed whether we should attempt large-scale projects to modify the weather. Their answer? "No!"

Dr. Edward N. Lorenz, a Massachusetts Institute of Technology meteorologist, worried over who would make weather-control decisions: "In this country, it would be some government bureau, and I shudder to think of the climate being modified by some bureau I could name," he said.

Sociologist J. Eugene Haas, of the University of Colorado, has investigated the social impact of weather modification. And his forecast is "stormy."

For instance, during a 1971 drought in Florida, ranchers and citrus growers clamored at the state capitol in Tallahassee for relief. Governor Reuben Askew summoned the NOAA to seed clouds over 4,800 square miles of central Florida. Rains came, and the cattlemen and citrus growers cheered.

Meanwhile, enraged tomato and melon farmers muttered about lawsuits.

(Continued on page 47)



SPECIALTY COMPANY

WRITE FOR FREE CATALOG
P. O. Box 60067, Chicago, Ill. 60660
5545 N. Clark St., Chicago, Ill. 60640
All Phone Orders 312/769-3581

**BLAZERS
SLACKS
BOWLING SHIRTS**



Be sure to order your Blazer Emblems & personalized rockers from Specialty... prices available upon request.



DUDE

The Dude is the latest style created for the Hilton line. EXTRA LONG, as you like it, in tried and true 50% KODEL® / 50% COTTON with PERMANENT PRESS qualities second to none. Contemporary contrast stitching and buttons emphasize the fine cut and style. Write for prices and the complete line of Hilton shirts.

BLAZERS & SLACKS

Whether for Lodge, District or State meetings or the Annual Convention, it is vitally important that your Lodge image be properly reflected by your Lodge Officers.

How better to put your best foot forward than in a SPECIALTY Blazer? Natural shoulder styling in up-dated traditional available in the genuine blazer model. Color-coordinated slacks are now available... write for color brochure and prices.

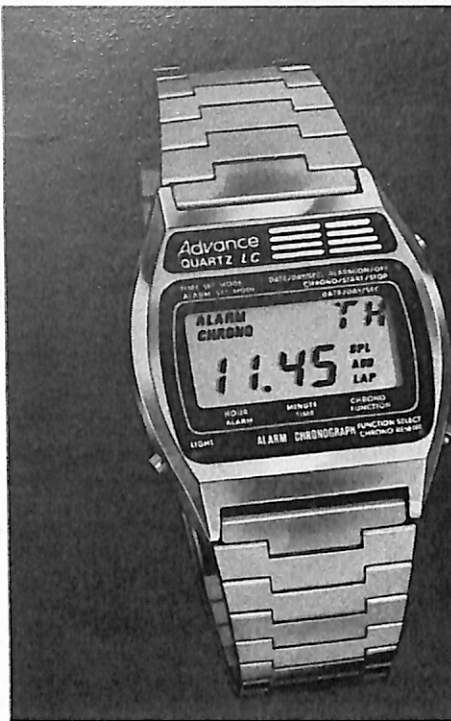

LCD Alarm Chronograph

The accuracy of the Greenwich observatory...with greater split-second precision than the finest Swiss stopwatch...plus the convenience of a 24-hour personal alarm reminder system.

This new LCD Chronograph is truly extraordinary. It does more, and does it better, than any other watch. With a strong, bold appearance that reflects this uncommon ability. The only little things about it are its thickness and its selling price, which is a real breakthrough at \$200.00 less than you'd pay for the only other watch even close to its functions and uses.

Quartz Crystal Time... It gives you accuracy to ± 60 seconds a year. A year! Quartz Crystal accuracy that would have been considered sensational *per month* in early micro-electronic watches. Accuracy which is still not available in many digitals that sell for \$500 or \$1,000.00!

Electronic Calendar... so, you always have exactly the right time on display—without pushing a button—in hours, minutes and running seconds. Then, at the touch of a button you can replace the seconds with the date or the day of the week, with the electronic calendar adjusting automatically for the number of days in any month. And you just light up the face to see perfectly when it's dim or you're in the dark.

24 Hour Alarm

You can set this alarm for any minute of any hour of the day or night. In all, 1440 positions are possible.

To wake you, remind you of an appointment, phone call or meeting (or to break one up that's been going on too long). The alarm will sound at the same time each day, unless you deactivate or change it. It will call you with an insistent, modulated beep, for a full minute unless you shut it off with a touch of the button sooner; and you can check to see if the alarm is set.

Is it any wonder that of all the features available in digital watches, a wrist alarm like this is the one that's most wanted? Really it's important enough to warrant your buying a new watch. And remarkable as it may seem, with this offer from Douglas Dunhill, it's like getting the alarm free!

Three Different Chronographs

As to the chronograph, its precision is so fine, it borders on the infinitesimal. Splitting each second into a hundred parts! Actually you have three different chronographs, or stop action modes of measuring. So you can time any event in its entirety, stopping during pauses or breaks in the action. You can time an event, like a race, from beginning to end, getting the finishing time of each participant in the race, or interim times, for the quarter, say, while timing of the event continues.

And you can time portions of a continuing event, like each lap in a relay race or segment of a complex, continuing manufacturing operation.

All this, with a few of the possible uses, is explained in detail below. Even from this brief description, though, the extraordinary sophistication of the micro-computer chip of the LCD Alarm Chronograph is apparent.

An Extraordinary Value

Right now, probably the only watch with all these features, its incredible accuracy, multiple function chronograph and wrist alarm, is the Seiko. And it regularly sells for \$200.00 more! \$299.95, even though the Seiko Chronograph is accurate to only a tenth of a second.

This extraordinary value is what convinced us, and we're one of the nation's oldest and largest mail merchandising firms, to secure the exclusive marketing rights. (After exhausting testing by our quality control experts.) We explained there was no way you would walk into a store and select a new brand from an unknown manufacturer.

How could you possibly be expected to appreciate its quality? Would you be in any position to understand and evaluate its virtually unique 3-function chronograph? Would you believe a sales clerk who told you it was really a finer, more accurate fully electronic, solid state watch than many that sell for as much as \$1,000.00?

Wear it for 30 Days —

Without Risk or Obligation

With us, buying by mail, you not only get all the facts, enjoy significant savings made possible by eliminating normal advertising and distribution costs, you can also try it for 30 days without risking one penny. We'll not only refund your money, but do so cheerfully.

You can wear the Advance LCD Chronograph Alarm for thirty days! Time to confirm the fact it won't gain or lose *five seconds* a month. To put the alarm to the test in your daily schedule. To satisfy yourself that the chronograph is as useful as it is easy to operate. More, to compare it with any watch at any price in any store. And to send it back if the value isn't as great as we say, if it doesn't win the admiration and fascination of your friends, earn your own pleasure and deep satisfaction.

Imagine, you can have one of the world's finest, most versatile watches for just \$100.00. That's complete, including shipping, handling, insurance and a handsome gift or presentation case. An exceptional bargain. Choose the chrome plated stainless steel model or gold-plated stainless steel one, each with a matching, extremely comfortable adjustable band.

Remember, your satisfaction is guaranteed. Your watch comes to you with a full *ONE YEAR* Limited Warranty. And you have our promise to service it to your satisfaction at any time. Remember, too, printed circuitry eliminates all moving parts and normal servicing, and will provide you with year after year after year of trouble-free performance.

With the LCD Alarm Chronograph you'll have the precise time, absolute control over time, plus ample warning when it's time to do anything. And the pride that comes with wearing a watch that's second to none.

Send your check (Illinois residents add 5% sales tax) to Douglas Dunhill, Dept. 78-3702 4225 Frontage Road, Oak Forest, IL 60452. Be sure to specify stainless steel or gold plate.

CREDIT CARD BUYERS

may call our toll free number

800-621-8318

(Illinois residents call 800-972-8308)

Call now for your no-risk, no obligation 30-day trial.

3 Way Chronograph

The micro-electronic revolution has turned the chronograph from a bulky pocket watch or cumbersome wrist watch for specialists into a sleek, super sophisticated instrument that's become the preferred timepiece for doctors, pilots, motion picture photographers, sound and efficiency engineers, skiers and sportsmen, and ever-increasing number of executives and others who enjoy split second accuracy and the ability to command time to stand still.

No other instrument, at any price, gives you greater precision than the 1/100th of a second accuracy of the LCD Alarm Chronograph or greater flexibility in timing an event from a fraction of a second to one full hour.

Add Time... is the stop watch mode you'll use for everything from timing a phone call to the length of a meeting; how long your car's been at a parking meter, the time you've been running, jogging or exercising, even the time it takes for a quarterback to set up and throw. Then, because you can stop it when necessary and start counting again when the action begins again, you'll use it to prepare your speeches, time games or other events in which you want the actual accumulated times exclusive of any breaks in the action.

Split Time... is the mode you'll use to get the time for the 1/4 and 1/2, 3/4 in a race, and the individual times of each contestant across the finish line. Think of it! Stopping for split times does not stop the timing of the event itself from continuing. It's actually stopped and running at the same time, so you can use it to figure out the time of pit stop, for example, and still get the over-all running time of the race.

Lap Time... is even more ingenious. It stops to measure an event and simultaneously starts again from zero. In a relay race, for example, you stop the chronograph the instant the runner passes the baton; this gives you his time while the lap timer automatically starts counting the next runner's time. Similarly, in a football game, you can get the exact time it takes a punter to kick the ball, the time the ball's in the air, and then the time of the run back of the punt. Any event, from a rocket launch to a production process, can be split into its component parts this way. Separating the time of elements that cannot be separated in any other way!

Within minutes you'll be able to use each of these modes of operation perfectly. Within days, find innumerable uses in both business and your personal life.



Dept. 78-3702
4225 Frontage Road • Oak Forest, IL 60452

**WANTED
SLOT
MACHINES
&
PARTS**



**BEST
PRICES
PAID**

It is legal for California Residents to purchase and own Antique Slot Machines. Will provide instant payment & transportation.

Any amount or condition

CALL COLLECT OR WRITE
MORRY O'CONNELL - (415) 785-0657
1675 Eastori Place / Hayward, CA 94545

• ALL REPLIES CONFIDENTIAL •

BINGO

**FOR PERMANENT
FUND RAISING**

Easy way to raise money for your Organization because everyone has fun playing BINGO! Thousands of Organizations are making up to \$500.00 per week using "BINGO KING" supplies and FREE Idea Bulletins. Write for FREE catalog and details on raising money for your Organization.

PLEASE GIVE NAME OF ORGANIZATION.

'BINGO KING'
DEPT. 808B, BOX 2499, LITTLETON, COLO. 80161

GAME ROOM EQUIPMENT

The Biggest Selection of Finest Quality

- POKER TABLES
- Non-Duplicate Monogrammed POKER CHIPS
- Imprinted PLAYING CARDS
- Monogrammed PERFECT DICE
- DICE CUPS

at the right price!

Write for Free Catalog Today!

GEORGE & CO., 615 Main St. Dept. E, Buffalo, N.Y. 14203



HEARING AIDS

MAIL ORDER SAVINGS
WRITE TODAY FOR DISCOUNT-PRICES ON YOUR FAVORITE MODELS

Behind the ear and all-in-the-ear and eyeglasses and body aids

From \$89 Send to:
ELECTRONIC PRODUCTS
Hearing Aid Division
P.O. Box 2005, Pinellas Park, FLA 33565

**WIN BIG OIL MONEY
PLUS TAX BENEFITS**

OTHERS DO EVERY MONTH IN U.S. GOVERNMENT OIL LEASE DRAWINGS. IF YOU ARE 21 AND A CITIZEN YOU CAN PARTICIPATE EQUALLY WITH MAJOR OIL COMPANIES IN THIS LEGAL LOTTERY. A \$25. TAX DEDUCTIBLE FILING FEE CAN RETURN UP TO \$75,000 AND MORE IMMEDIATELY PLUS A POSSIBLE FORTUNE IN FUTURE INCOME. WRITE DEPT. 7 FOR FREE INFORMATION.

F. MILLIGAN INC., 600 MANHATTAN, BOULDER, CO 80303



ELECTRIFY YOUR BIKE!

PEDALPOWER exciting new bike drive tames tough hills. Be independent. Shop when you want. Fits all Bikes, Adult Trikes. Installs in minutes. Thousands sold. Recharges overnight. Travels 100 miles for a dime. Call or send for FREE illustrated booklet.

CALL FREE
800-257-7955

GENERAL ENGINES CO.,
5062 Mantua Blvd., Sewell, N.J. 08080



YOU AND RETIREMENT

by Grace W. Weinstein



NO MORE RETIREMENT?

A large-scale guessing game is under way among American businessmen. When, on January 1, 1979, non-governmental employees between 65 and 69 can no longer be asked to retire, what will happen? Will every older worker stay on the job? Or will retirement rates continue in much the same pattern?

It's probably safe to say that the actual answer will fall somewhere in between. But no one really knows. The experts—economists and actuaries and managers—are all trying to figure out what older workers will decide to do and what the impact will be. Many of these experts, together with corporate executives, got together recently in New York City, at a meeting sponsored by The Conference Board, to consider the question.

First, what does the law say? The 1978 Amendments to the Age Discrimination in Employment Act raises from 65 to 70 the age at which most employees can be required to retire. The exceptions include employees of companies with fewer than 20 employees, executives whose pensions would be more than \$27,000 a year, tenured university teachers, and people in high-risk jobs. Everyone else in the private sector—70 percent of American workers—can now work until age 70 if they so desire.

But do many people so desire? Right now, although women are working longer than ever before, more and more men are retiring early. The numbers increase each year. In 1970, 63 percent of the 65-year-old men eligible for Social Security were receiving benefits; 2/3 of them were receiving benefits reduced for early retirement. In 1976, 80 percent of those eligible at 65 were receiving benefits, and 3/4 were receiving benefits reduced for early retirement.

Men are retiring early for a number of reasons, according to a Conference Board study by Shirley H. Rhine. Among these reasons:

- ⊙ Increased eligibility for Social Security among men over age 62, and the liberalization of Social Security benefits;
- ⊙ Increased coverage by private pensions, and the inclusion in more private pension plans of provisions for early retirement.

With liberalized social security and pension benefits, there is little financial incentive for many men with less-than-

executive salaries to continue working. In an example provided at The Conference Board meeting by Bruce R. Ellig, Corporate Director of Compensation & Benefits for Pfizer Inc., an employee who will be 65 this year, with a spouse of the same age who is not working, earns \$22,900. After paying federal and New York state income taxes and over \$1,400 in Social Security deductions, the employee is left with about \$17,000 of after-tax income. If this employee chooses to retire, Mr. Ellig continues, his 35 years of service might yield a pension of about \$7000. Taxes on this sum, assuming standard deductions, would be about \$50, leaving \$6950. He and his wife would also receive tax-free social security retirement benefits of approximately \$9000. After-tax income after retirement would thus be about \$16,000; after-tax income if he keeps right on working is about \$17,000. Our hypothetical individual, under these circumstances, would probably retire.

But what if he likes his job and keeps right on working. Government actuaries estimate that 200,000 over-65 workers may stay on the job under the new law. But no one knows if this figure is accurate. And, even if it is, no one knows how long they will continue working. In the meantime, the experts guess, the possible impact includes:

- ✓ Programs to encourage earlier retirement. Some companies, eager to smooth the way for younger employees, may provide incentives to older workers to retire early.
- ✓ There may be less job security for marginal older workers. Where employers may have been willing to let older employees coast downhill to certain retirement at age 65.
- ✓ There may be somewhat more funds for Social Security, since older workers who keep on working keep on contributing to the Social Security trust fund.
- ✓ Inflation continues to be the biggest problem facing retirees. People who would like to retire early are frightened, not unreasonably, by continuing inflation and the undermining of purchasing power. Pensions, unlike wages, seldom go up with the cost of living; that cost, especially in medical care and housing, continues to spiral ever upwards. Inflation alone may keep older workers working past their planned date of retirement. ■

a new dimension in smoke alarm technology

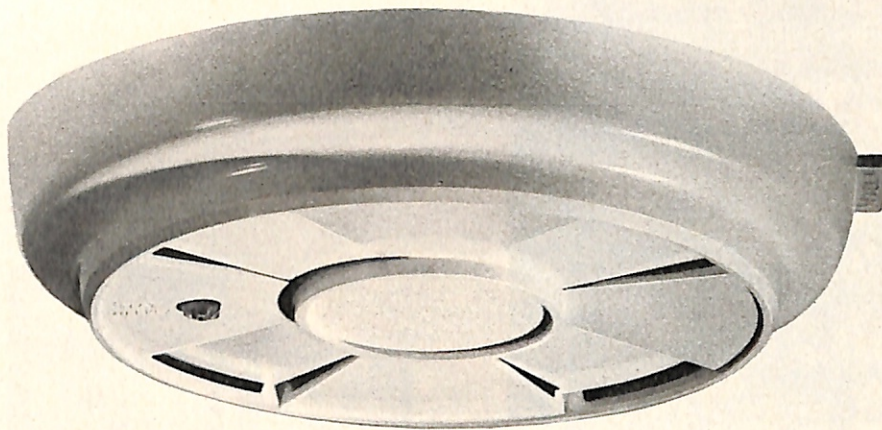

new solid state smoke alarm continually monitors the air for smoke and fire without battery replacement for 10 years

LIFESAVER PLUS™

the only smoke alarm with a 10 year battery and 10 year warranty

Smoke alarms are a necessity, not a luxury. They are inexpensive and, without question, one of the best investments you can make for your family's protection.

If you want to own the very best solid state alarm with computerized circuitry, a battery that lasts for 10 years and a 10 year warranty on both battery and detector, check the Lifesaver Plus features. They're designed with your safety in mind.

WHY A SMOKE ALARM?

Most fatalities occur at night and the majority of victims are never touched by flames. They are overcome by smoke and gases as deadly as fire. Our new Lifesaver Plus smoke alarm is designed to alert you of either fast developing or smoldering fires with its loud penetrating warning so you can protect your home, possessions, and most of all, your life.

HOW DOES IT WORK?

The PDM Lifesaver Plus smoke alarm works on the "ionization" principle of fire detection. Inside the detector is a unique balanced stainless steel dual ionization chamber design with a superior teflon insulator for long life and reliability. The "reference chamber" is designed to keep the sensitivity level constant during normal atmospheric changes in your home. The "sensing chamber" continually monitors the air 24 hours a day and initiates an alarm when smoke and particles of combustion are present. An automatic reset shuts off the alarm when smoke or particles of combustion clear the chamber.

AUTOMATIC ELECTRONIC CHECKING

The PDM Lifesaver Plus smoke alarm has a testing system that does more than just check the battery to see if it's low. Pressing the test button electronically checks the entire alarm circuitry including the calibrated sensitivity, horn and battery. If the unit is functioning properly, the alarm will sound. Also perfect for fire drills.

THE BATTERY LIFE BREAKTHROUGH

The detector is battery powered by the

new 10 year UltraCell 9 volt smoke alarm battery, especially designed for the PDM Lifesaver Plus smoke alarm. The UltraCell battery utilizes the active metal lithium and a gaseous electrolyte in hermetically sealed cells. The unique stable chemistry provides a higher cell voltage, more power per unit weight and volume, a wider temperature range and longer life than previous commercially available batteries.

When battery needs replacement, a built-in low battery indicator "chirps" every minute for up to 7 days. Even in an emergency the smoke alarm will function perfectly during the chirping period.

CHECK THESE IMPORTANT FEATURES:

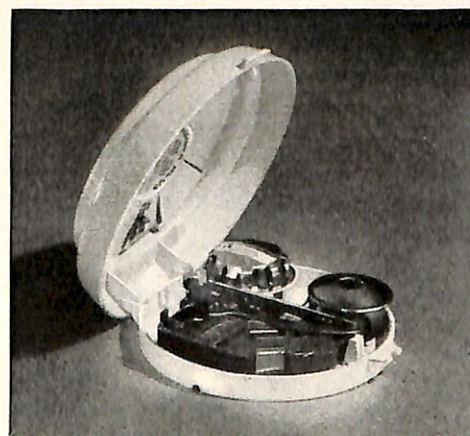

1. Dual stainless steel ionization chamber design with superior teflon insulator.
2. Loud, penetrating 85 decibel horn.
3. Battery powered with the new special 10 year UltraCell smoke alarm battery.
4. Convenient test button checks alarm circuitry, horn and battery.
5. Solid state circuitry for reliability, long life and stability.
6. Impact resistant case with open cover tab for easy access to battery.
7. Easy installation with 2 small screws provided—no wiring required.

The PDM Lifesaver Plus smoke alarm gives you more than just a smoke alarm. It gives you all the latest developments and technological advances, proven performance, plus 10 years of service before battery replacement is necessary. Don't be confused—you can't buy a better smoke alarm—plus a 10 year warranty on top of it! The PDM Lifesaver Plus smoke alarm is designed to give you quality, dependability, efficiency and long life.

The unit is easily installed on either ceiling or wall with 2 screws provided. Also included is an operating manual with escape plan, locations for alarms and good safety habits.

To order, send coupon and your check or money order for \$24.99 (Illinois residents add 5% sales tax) plus \$1.50 postage and handling to PDM Sales, Dept. EK8, 119 S. Emerson St., Mt. Prospect, IL 60056. If coupon is missing, send order to PDM. Be sure to indicate number of smoke alarms desired. Credit card buyers may call our toll-free number.

pdm sales

119 S. Emerson St., Mt. Prospect, IL 60056

CALL TOLL-FREE . . . (800) 621-0660
In Illinois Call (312) 641-6969

PDM Sales
119 S. Emerson St., Mt. Prospect, IL 60056

Please ship _____ PDM Lifesaver Plus Smoke Alarms
@ \$24.99 each. Enclosed is check money order
(Illinois residents add 5% sales tax) plus \$1.50 postage and handling for \$_____.

Name _____
Address _____
City _____ State _____ Zip _____

Please charge my order to: VISA/BankAmericard
 Master Charge
 Diners Club
 American Express

Account No. _____
(Master Charge must also include number above name on card.) _____

Signature _____ EK8

Using melted snow to develop negatives, William Henry Jackson became the first man to photograph Yellowstone Park, the Colorado Rockies, and the ancient cliff dwellings of Mesa Verde.



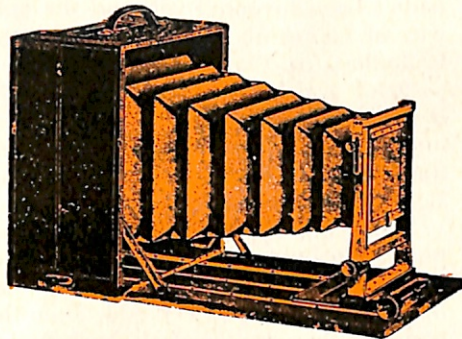

FRONTIER PHOTOGRAPHER

by Richard Grant

In 1871 it was known as Colter's Hell—a strange and frightful valley said to be filled with bubbling caldrons of mud, fountains of boiling sulfur, and geysers of hot water that shot hundreds of feet into the air. But that was if you believed the rumors. John Colter, a member of the Lewis & Clark Expedition, was the first to wander into this mysterious valley in Wyoming, but nobody believed his description of the place. For the trappers and prospectors who worked the area, seeing Colter's Hell became a lot like seeing a UFO; you might tell a few friends about it, but not if you wanted to be thought sane. Even the respected guide Jim Bridger was laughed at when he talked of it. But all that changed in 1871.

The man most responsible for this change was a young photographer named William Henry Jackson. Until he rode into Colter's Hell on the back of a mule, Jackson had not exactly carved his name on Western history. In 1866, after a fight with his fiancé, he left Vermont, and following Horace Greeley's advice, headed west as a bull-

whacker on a wagon train bound for Montana. With the Civil War over, thousands of foot-loose youths were pouring into the wild territory west of the Mississippi, and Jackson just blended in with them.

For a year he drove wild horses, worked on farms and ranches, and did a little bit of everything, but mostly he worried about where his next meal was coming from. Finally, down to his last \$175, he landed a job as a photographer's assistant in Omaha, Nebraska. Business was good in the railroad boom town, and Jackson was a natural for the job, so it wasn't long before he bought out his employer and set out to make a name for himself.

His first project was riding the newly completed transcontinental railroad, taking pictures along the way—sometimes from the cowcatcher on front of the locomotive, but more often in the towns springing up along the line. The set up was this: Jackson would scour the town taking photographs of the best looking establishments, and then his assistant, Hull, would take the pictures

around and try to sell them. Sometimes it worked. In Cheyenne, Wyoming, with the help of two bottles of wine, Jackson and Hull got sixty dollars from Madame Cleveland and her girls. But often it didn't and they ended up giving away as many pictures as they sold.

The trip on the Union Pacific was successful in one respect though, it led to Jackson's association with the Hayden Geological Survey. He couldn't have found a better job.

Led by Ferdinand Vandiveer Hayden, the survey was made up of a group of scientific specialists hired by the government to enter unknown regions of the West to find out what was there. In addition to being a hard working geologist (the Indians called him Man-Who-Picks-Up-Stones-Running) Hayden was a shrewd politician. He realized from the start that the new art of photography could play an important role in securing funds for his survey, and he set out to get the best field photographer he could find. Young Jackson proved to be his man.

On their first survey together, in the

Introductory Offer. . .SAVE UP TO 20%

OFFER EXPIRES DECEMBER 31, 1978

ORIGINAL
SWISS ARMY KNIVES

-MADE IN SWITZERLAND-

"THE GENUINE SWISS ARMY KNIFE"

The Handiest Pocket Tool Chest in the World

- Specially compounded tenite butyrate handles permanently bonded (no rivets). Official Swiss Army red.
- Durable key chain holder.
- Swiss aluminum electro-plated dividers.
- Swedish stainless steel blades, instruments and springs.

from.. **QUINN** * PRECISION INSTRUMENTS, INC., P. O. BOX 907, NIAGARA FALLS, N. Y. 14302

-GUARANTEED FOR A LIFETIME-

SPECIAL PRICES INCLUDE POSTAGE & HANDLING CHARGES

No. 121



MATTERHORN.....\$39.95
World's Largest Swiss Army Knife
15 Tools for Over 30 Jobs

No. 122

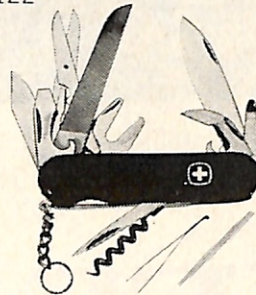

PATHFINDER II.....\$29.95
12 Tools for 20 Jobs

No. 120

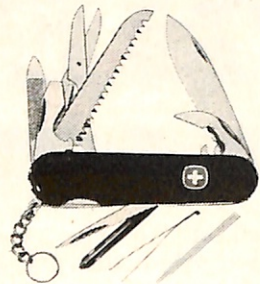

HANDYMAN.....\$24.95
10 Tools for 21 Jobs

No. 119

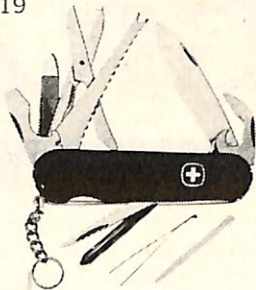

MASTER FISHERMAN.....\$24.95
10 Tools for 22 Jobs

No. 118

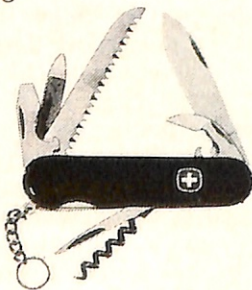

THE BACKPACKER...\$19.95
7 Tools for 18 Jobs

FREE! COLOR CATALOG

Our New 24 Page - Full Color Catalog featuring over 100 Products FREE with each order or \$1.00 each without purchase for mailing.

- Personalized Swiss Army Knives.
- New Pro-Flex Swiss Filet Knives.
- Sporting Cutlery from Deerslayer.
- European Compasses/Map Measurers.
- Swiss-made Stopwatches/Syncrotimers.

... and MUCH MORE. SEND TODAY!

Make payments to:- **QUINN** [SORRY - No C.O.D.s]
P.O. BOX 907, DEPT. E-8, NIAGARA FALLS, N.Y. 14302
-PLEASE RUSH ME-

- ___ 118 Backpacker @ \$19.95 ___ 119 Masterfisherman @ \$24.95
___ 120 Handyman @ \$24.95 ___ 121 Matterhorn @ \$39.95
___ 122 Pathfinder II @ \$29.95 ___ Leather Belt Sheath @ \$4.95

If not satisfied, I understand I may return my purchase within 10 days and receive a full refund.

___ I enclose check or money order for \$ _____
(New York residents add sales tax)

___ Please send me your NEW 24 Page-Full Color Catalog @ \$1.00 each or FREE! with my purchase.

___ Master Charge ___ Bank Americard/Visa

Acct No. _____ Exp Date _____

Interbank No. (Master Charge only) _____

Signature _____

NAME _____

ADDRESS _____

CITY _____

STATE _____ ZIP _____



summer of 1870, Jackson received no pay, but he did get his expenses paid, and more important, he learned a

career. Photographing in the field at this time was a complicated process, and one for which there were very few precedents. When traveling by railroad, Jackson had carried equipment weighing nearly a ton; now, restricted to what could be carried by mule, he had only three hundred pounds of cameras, chemicals, and glass plates.

Dry film (film as we know it now) hadn't been invented yet, and the only way of taking photographs was by the Collodion, or Wet Process. In this, a plate of glass was covered with collodion, and while it was still tacky, dipped into a solution of silver nitrate. This formed light sensitive salts in suspension on the collodion coating.

The plate, while it was still wet, was put into a light-tight holder, run to the camera (which had to be already set up and focused) and exposed. Then the photographer had to dash back to his darkroom, and develop, fix, and wash the plate before it dried out. The whole process took thirty to forty minutes, but could, if pressed, be done in fifteen.

There was no enlarging back then. If you wanted a picture 11 by 14 inches, you had to expose an 11 by 14 inch piece of glass. Easy enough in a studio, but out in the wilderness there were problems. Where did you get a darkroom, and what did you do with the fragile, and valuable, exposed glass plates?

Jackson solved the first problem by using an orange calico tent. This could be set up fast, and it let in just enough light to see, but not enough to fog the negative.

He never solved the other problem. Most photographers used a wooden box with grooves that held each piece of glass separately, and Jackson followed suit, however, many of his fine photographs were destroyed by bucking mules.

All through that first summer together, Jackson and Hayden heard stories of Colter's Hell, so there was little doubt where they would go on their next survey. *Scribner's Magazine* printed a story about the strange valley by Nathaniel Langford, and, although Langford was called the "biggest liar in the West," people were interested. Even Congress was interested, but what was required was tangible proof—the type of proof only William Jackson could provide: photographs.

And provide them he did. For forty days in the summer of 1871, the Hayden Survey walked, rode, and explored Colter's Hell, finding that, if

(Continued on page 48)

Four of America's Last Great Antique Buys!

Genuine Circa 1900 Antiques.
When they're gone,
they're gone forever.



The Round-Top Schoolhouse Clock (Style 14)
\$110.00

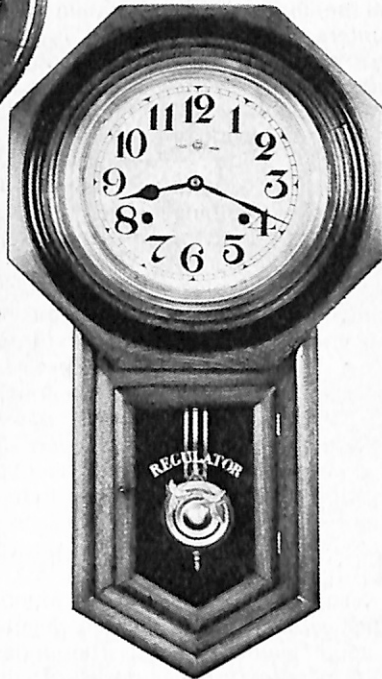

The Ring Octagon Schoolhouse Clock (Style 13)
\$115.00

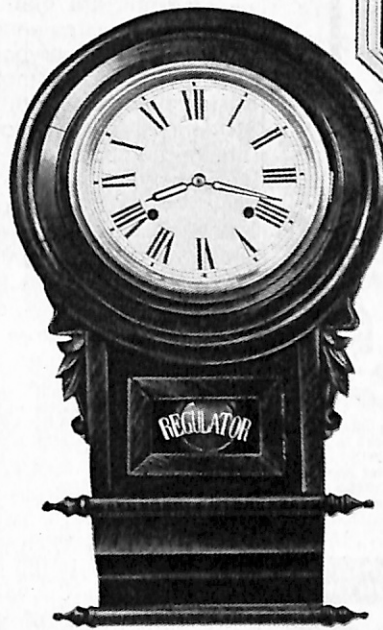

The Classic Double Scroll Clock (Style 15)
\$115.00



The Old Schoolhouse Clock (Style 11)
\$115.00

We urge you to take heed. These are truly the last of the Great Old Clocks. At our low price, you may never see these values again. Authentic circa 1900 antique school-room clocks, the kind that once ticked happily away in the front parlours, general stores and one-room schools of America's childhood. Lovingly restored and in 100% running order. Each is unique—yours will be numbered, registered to your family or whomever you designate and accompanied by a handsome Certificate of Age and Ownership (suitable for framing). Order now, to avoid disappointment. When these clocks are gone, they're gone forever.

- Clocks, we believe, will appreciate many times in value in the years to come.
- Certificate of age, authenticity and ownership.
- Fully re-conditioned 8-day keywind movement, brass pendulum, key. Counts each hour in deep, melodic tones.
- Finely polished and carefully restored hardwood case, approx. 22" H, 13" W, 4½" D.
- Sturdily cartoned and shipped to you UPS insured.

FOR FASTER SERVICE ON CREDIT CARD ORDERS
call (914) 248-7031 9 a.m. to 5 p.m. (E.S.T.)
Visit our Showroom, just 1 hour from N.Y.C.



Pony Express System
2986 Navajo St., Dept. M-820, Yorktown, N.Y. 10598

Gentlemen: Please send me the following clock(s) (state qty.):

- _____ The Round-Top Schoolhouse Clock (Style 14) @ \$110.00
- _____ The Ring Octagon Schoolhouse Clock (Style 13) @ \$115.00
- _____ The Classic Double Scroll Regulator (Style 15) @ \$115.00
- _____ The Old Schoolhouse Clock (Style 11) @ \$115.00
(add \$6.00 for each insured delivery.)

If these clocks are to be Gift orders, please attach a separate sheet of paper stating the name the clock is to be registered to, and name and address for shipment. We will enclose a gift card at your request. On multiple orders, be sure to specify who gets which clock.

My check is enclosed for \$_____ (N.Y. State residents add 5% tax.)

I prefer to charge my (check one)

American Express Bank Americard Master Charge
Account No. _____ Expiration Date _____

Signature _____

Mr./Ms. _____

Address _____

City _____ State _____ Zip _____

Satisfaction Guaranteed



SAVE HUNDREDS OF DOLLARS

Possess the gem that's as brilliant as a diamond.

The incredible **MAGIC FIRE™** has more "fire" than a glittering natural diamond. Own the dazzling impact of diamonds that can easily sell for up to \$1,000 per carat — for a fraction of the cost. From \$35 a carat and set in 14K Solid Gold. Bank credit cards. Send for our Free catalog of pendants, earrings, and rings for men and women.

MONEY BACK GUARANTEE
Guarantee available on request.

The Crown Collection Dpt. EL-8
509 Madison Ave, NY, NY 10022

DON'T QUIT SMOKING

before giving my pipe a 30 Day Trial



My new principle contradicts every idea you've ever had about pipe smoking. I guarantee it to smoke cool and mild hour after hour, day after day, without rest, without bite, bitterness or sludge. To prove it, I'll let you test smoke a Carey Pipe for 30 days. Write today for **FREE** trial offer. E. A. CAREY, Dept. 204K, 3932 N. Kilpatrick, Chicago, Ill. 60641

MODERN - OBSOLETE - FOREIGN
DOMESTIC - MILITARY - SPORTING

WORLD'S LARGEST SUPPLIER
GIANT CATALOG #7
\$2.00 PDD

GUN-PARTS

NUMRICH ARMS CORP.
Box ELK, West Hurley, New York 12491

HEARING AIDS

SUPER SAVINGS! Newest. Finest. All types. Buy **DIRECT & save up to HALF!** No salesmen. Sold by **AIR MAIL on HOME TRIAL. FREE Catalog.** Write: **MONEYSAVERS**, Dept. EK-8, 9530 Langdon Ave., Sepulveda, Cal. 91343

SAVE 1/2!

FREE CATALOG — WRITE!

ENJOY GOLF

Golf is **more fun and less tiring** using the **Adjustable® All-In-One** golf club. Sets to driver, 3, 5, 7, 9 iron and putter. \$44.90 Ppd. Money back guarantee. For information call 219-234-4400 or write: **International Golf Products, Dept. E-8** 1865 Campeau St. South Bend, IN 46617

REMBRANDT DID IT IN OILS...

Let us do it in **BRONZE PLAQUES**

FOR ALL OCCASIONS
Write for Free Catalog E23
Engraved Plaques E21

INTERNATIONAL BRONZE TABLET CO., INC.
150 W. 22nd St., N.Y., N.Y. 10011 212-WA 4-2323



MEDICINE AND YOU

by Larry Holden

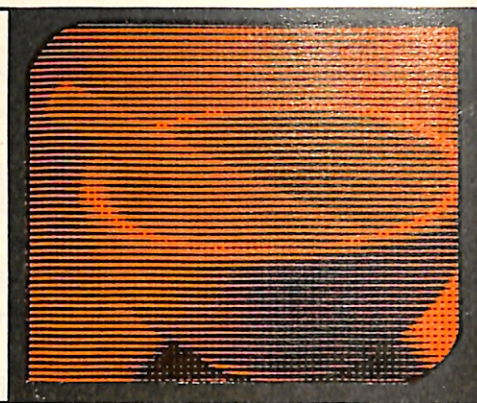

VITAMINS: THE MYTH AND THE MAGIC

Vitamins are one of the least understood substances encountered in our day-to-day living. Everybody's heard of them, but few people—including many scientists, medical practitioners and even nutritionists—really know how they work in the human body.

Depending on which group of experts you listen to, the importance of vitamins ranges from an overrated would-be panacea for anything that ails you, to something of value that the medical profession has closed its collective mindsto. But all groups agree on one point: ever since Casimir Funk came up with the term "vitamins" in 1916 a controversy has swirled around them.

Vitamins are essentially chemical substances that the body doesn't produce. They must be introduced into the body's system from some outside source.

It's now generally agreed a balanced diet which meets the RDA for vitamins A, B₁, B₂, D and C will also provide the needed amounts of other vitamins and minerals necessary for good health. The simplest way to obtain the necessary nutrients is to follow a good balance of food in the four larger groups—milk, meat, vegetables and fruit, bread and cereal.

While it's a fact that a person severely lacking in specific vitamins can develop certain diseases, there's little proof that taking extra vitamins will cure similar non-vitamin deficient conditions.

The taking of large amounts of vitamin E has been claimed to prevent heart attacks, slow the aging process, ease the effects of air pollution and increase sexual potency/performance. There is not yet any unrefutable scientific proof that supports this claim.

Vitamin therapy isn't new and certainly has a basis in fact. In 1745, James Link, a British Navy physician, determined that there was a relationship between the diets of British sailors on long sea voyages and the outbreaks of scurvy that plagued nearly every ship. The lack of vitamin C in their diets caused the scurvy.

Vitamin C has in recent years been a controversial item. Some noted people say that taking large amounts of vitamin C will prevent colds or at the least lessen the effects should you get one.

There is real danger, though, in accepting the idea that if a little bit of a

vitamin is good for you, then taking a lot of it is better. Once a day millions of Americans pop a vitamin pill—or two or three—on the theory that if one is good more could be better, and vitamin overdoses are becoming a major source of accidental poisoning.

Vitamin A, found in milk, butter, fortified margarine, eggs and vegetables, is essential for normal growth, normal vision and healthy skin and hair. But overdosing on vitamin A can create pressures within the human skull just like those of a brain tumor.

Excessive doses of vitamin D can retard mental as well as physical growth, cause nausea, weakness, hypertension and even death. Vitamin D is obtained from adequate exposure to sunlight and can be found in small amounts in milk.

Excessive amounts of vitamin C over a long period of time can result in chronic diarrhea and kidney stones. The vitamin is found in fruit juices, tomatoes and green vegetables.

The undesirable side effects of large doses of vitamin E can be headaches, dizziness and blurred vision. The richest source of this vitamin is vegetable oils.

The numerous vitamin Bs do aid in the conversion of food to usable energy, but if taken in amounts greater than the recommended allowance they provide nothing of value.

Vitamins are neither harmless substances nor cure-alls. They are an integral part of the human body. It's likely most people get enough vitamins in their daily diet. On the other hand, taking a daily multi-vitamin tablet does you no harm and might be considered an insurance against some deficiency or another.

If you do take a multi-vitamin, buy the least expensive ones you can find. It's a common myth that natural vitamins are better than the synthetic kind. Not so.

Vitamins aren't a substitute for proper diet and exercise, and in the end, it all comes down to some basic rules about eating. A body needs vitamins and other nutrients but it also needs the texture and bulk of real food. Just remember that you need a good balance of those foods to give you the vitamins you need.

Note: The FDA pamphlet, Myths About Vitamins, can be obtained free by writing the Consumer Information Center, Department 562 F, Pueblo, CO 81009.

Stacy Hover and her teddy bear tested the comfort of the wheelchair given to her by **Rock Island, IL, Lodge**. Est. Lead. Kt. and Youth Chm. Al Nes-seler (left) and ER Jack Objartel made the presentation on behalf of their Brothers.

Kevin Dickman (left), **Piscataway, NJ, Lodge** Crippled Children's Committee poster child, received professional instructions from ER Ed Greenwald before throwing out the first ball at the Piscataway Elks and WABC-TV (New York) Eyewitness News Team "All-Stars" softball game. The local Brothers, managed and captained by

NEWS OF THE LODGES

es of **New Jersey's Southwest District and Augusta, ME, Lodge** also paid tribute to Boy Scouts. New Jersey Elks held a Career Dinner Night which was designed to help Burlington County Scouts plan for the future, and Augusta Brothers honored two Eagle Scouts of Troop No. 603 for obtaining the highest rank in Scouting.

For the benefit of Elks Aidmore Children's Home, **La Grange, GA, Lodge** held a holiday ball. The affair

An Elks fishing club has been organized by **Queens Borough (Elmhurst), NY, Lodge**. The Brothers have invited any interested Elks in the surrounding areas to join them in their aquatic hunting.

Scholarships were awarded to six high school students by **Fullerton, CA, Lodge** during a dinner honoring the recipients. Then-ER Michael Petrunio was on hand to present the checks which amounted to \$600. Two of the recipients were also academic award winners on the district level.

Former Brooklyn Dodger pitcher Carl Erskine received a Citizen of the Year award from **Anderson, IN, Lodge**. Then-ER Richard Townsend was on hand to present the certificate and to commend the ex-Dodger for his work in the community.

Membership in the National Foundation continues to grow with the addition of contributions from **Point Pleasant, NJ, Lodge**. PER William Roberts joined new Foundation members Ed Chrvala, Russ Wilcox, and Gus Schipani when he received his membership certificate from lodge Foundation Chm. Robert Hickethier.

The Motorcycle Drill Team of **Orlando, FL, Lodge** has not only made appearances at parades and entertained at the Harry-Anna Hospital, but has also provided visiting dignitaries with an escorted welcome. Then-GER and Mrs. Homer Huhn, Jr. were recently greeted in Orlando by the team's sirens and flashing lights.

In recognition of Brother Wadsworth Blythe's contributions to the National Foundation, **Las Cruces, NM, Lodge** awarded him an honorary founder's certificate. PER Freddie Covington, state chairman, presented the certificate during a PER Night and thanked Brother Blythe for his donations, which totalled \$1,000.

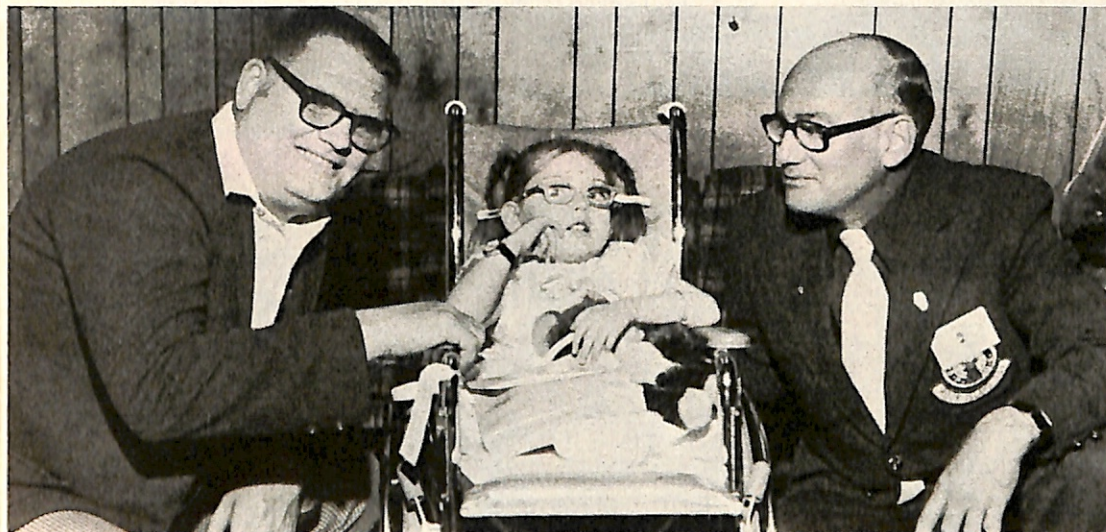

Rock Island, IL, Lodge's wheelchair presentation to Miss Stacy Hover

Chap. Artie Johnson, defeated the news team, 11-10, in nine innings before 2,000 fans. CP Chm. Jack Carbley reported that the committee had raised enough revenue from the game to send 20 Piscataway applicants to Elks Camp Moore during the summer.

A grand tenth anniversary celebration took place at **Front Royal, VA, Lodge** recently. Those who attended the dinner-dance and two luncheons included SP Bernard Kofira, VPs Robert Pannell and Donald Netschke, PER Paul Kelly, VP of Virginia Elks Boys' Camp, and the lodge's first Exalted Ruler, Curtis Breedlove, who came from his present home in Florida for the celebration and received a plaque for his outstanding service to the order from PGER John Walker. Assisting Chm. and Est. Lect. Kt. Richard Williams in organizing the festivities were ER Rolf Bean and PER Samuel McCauley.

Boy Scout Troop No. 440 was honored by its sponsor, **Buena Park, CA, Lodge**, during a special banquet. The Brothers commended the Scouts, who have been recognized nationally for their many accomplishments. The lodg-

was organized by the Elk's ladies, and with the help of the Brothers they raised \$500.

Red Cross and Port Clinton, OH, officials praised the Brothers of **Port Clinton, OH, Lodge** for their aid and the donation of their facilities during the past winter's major blizzard. The lodge was the only official Red Cross Emergency Center in Ottawa County and was manned by the Brothers. Est. Lead. Kt. Ray and Mary Ellen Raypole were on duty during the entire storm.

At the Piscataway Elks-Eyewitness News Team softball game



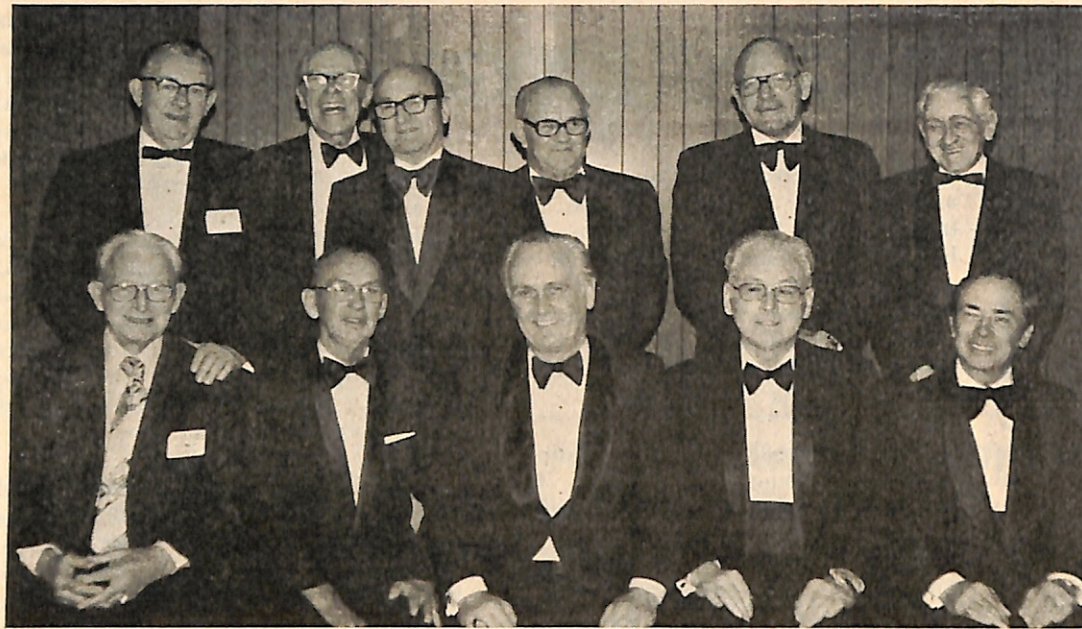

CANDIDATES for membership in the order were initiated at Alameda, CA, Lodge by the Past Exalted Rulers during PER Night. (Front row, from left) John Bajuk, George Campbell, PDD Bill Lawrence, Larry Keenan, Mel Melby and (back row, from left) Al Gillard, Paul Krausse, Lou Schroeder, Adolph Camisa, Grant Eaton, and Markham Happ were the 11 PERs who conducted the ceremony, which was preceded by a dinner celebration.



MEMBERS of Pawtucket, RI, Lodge and city officials met at City Hall for the Brothers' presentation of a wheelchair to Normand Brunelle (center), an employee of the accounting department. (From left) PER Walter Petrucci, Brother Paul DelPape, Committee Co-chm. Bill Malloy, Brother and Police Lt. Kenneth Gendron, ER Gilbert Bettencourt, Trustee Alfred DelPape, Committee Co-chm. Jack DiGiovanni, and Mayor Dennis Lynch were on hand when Mr. Brunelle accepted the wheelchair, which will increase his mobility and aid him in the performance of his job.



ELKS of Panama Canal Zone (Balboa), CZ, Lodge recently honored PDD Stewart Brown (left), Eugenia Bing (second from left), the wife of Brother John Bing, Brother Burton Mead (third), and Brother William De La Mater (right), who had received Honorary Public Service awards in recognition of their contributions toward improving the Isthmian community. Governor H. R. Parfitt was on hand to congratulate the four people, who were among 22 recipients of the awards.



FOLLOWING their completion of the Multiple Sclerosis Society Bike-A-Thon's 25-mile course (from left), Janice Smith, Kathy Patrick, and Gerrie Wilcox, Elks' ladies of Chattanooga, TN, Lodge, presented a \$725 check to Roy Exum, bike-a-thon chairman. The ladies, who sponsored the project within the lodge, offered special thanks to the Brothers who pledged the funds which were donated.



EXALTED RULER Michael Hoblock Jr. (left), Youth Chm. Joseph Hull (right), and Teenager of the Year Cynthia Fuess (second from right) were present for the official signing of a Youth Week proclamation for Colonie, NY, by Town Supervisor Fred Field. The theme of Colonie Lodge's program in honor of the local youngsters was "youth of today, leaders of tomorrow."



◀ **A FRAMED** copy of a newspaper story about Manasquan, NJ, Lodge's Mother of the Year was presented to the honored lady, Harriet Nock (seated), by ER Roger Knox, while her son Willard Nock observed. Known to the Brothers as "Nanny," Mrs. Nock was officially recognized by the lodge for her numerous charitable activities, particularly the crocheting of hundreds of wool afghans and lap robes for senior citizens, which are presented in the name of Manasquan Lodge.

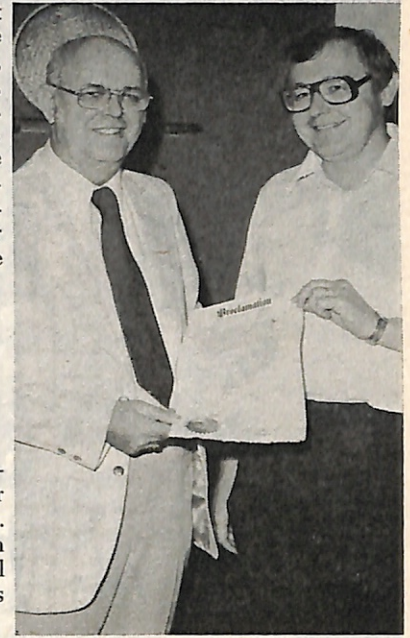

PALM SPRINGS, California, Brothers received the support of the town in their promotion of activities for area youngsters. ER Charles Malin accepted a signed Youth Week proclamation from Mayor Russell Beirich, who commended the lodge for its programs for the young people.



A PROCLAMATION from the Town of Hempstead declaring Youth Week was given by (from left) Councilman Joseph Cairo to Elmont, NY, Lodge Brothers Trustee William Savino, ER Robert Lange, Angelo DeLuca, Est. Lead. Kt. Angelo Auriemma, Est. Loyal Kt. Michael Starito, and Est. Lect. Kt. Jack Bluebello. Elmont Elks sponsored a tribute to the junior citizens of the local community during the week following the presentation of the proclamation.



A COLOR television set was purchased for the Jerry Reltis VA Hospital in Loma Linda, CA, with a \$455 donation from Pomona, CA, Lodge. Vets Chm. John Porto (right) presented the check to Herb Daykin, chief of voluntary service at the hospital, while (from left) Brothers Ross Bougher, Est. Lead. Kt. Al Owings, and Dist. Vets Chm. Ron Holland observed. The Pomona Elks also contributed \$150 in toilet articles and over 250 magazines and paperback books to the hospital.

A MAJOR expansion of Nashville, TN, Lodge facilities began with the groundbreaking ceremony, which was led by ER Billy McElhaney (seventh from left) and Trustee Harry Lester (eighth). Also in attendance were (from left) Secy. Edward Wohlbold, PERs Don Johnson and Billy Vaughan, Trustee Sam Wilkerson, James Kennon, contractor, N. B. Purvis, architect, Trustee Sam Aaron, Est. Lead. Kt. William Williams, and Trustee Barton Cloud.





BROTHER John A. Schneider (second from right) of Olney, IL, Lodge was inducted into the Illinois Basketball Hall of Fame recently. With a coaching record of 350-150, Brother Schneider has coached his teams to one state championship, one second-place finish, 12 regional championships, and 7 sectional titles and is head basketball coach at New Trier East High School in Winnetka, IL. Brother Schneider's wife Suzanne (right) and his parents PER John T. Schneider of Olney Lodge and Mrs. Schneider joined the many Elks at the Hall of Fame dinner in Normal, IL, in congratulating Brother Schneider.

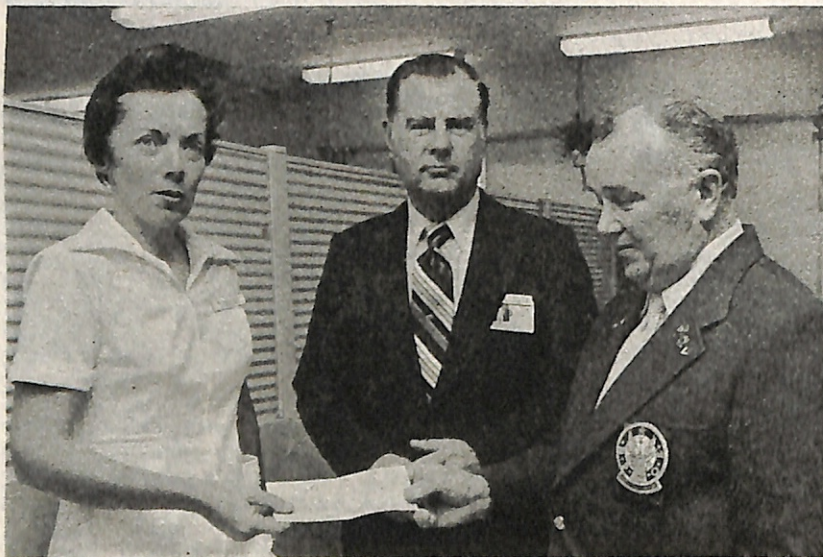

THERAPY equipment for veterans with hand and arm trouble was bought by the Miami VA Hospital with funds provided by North Palm Beach, FL, Lodge. Vets Chm. John Busby (right) presented the \$400 check to Mrs. M. Willis (left) and Thomas Dorthery, hospital director, who purchased a shoulder wheel and a wrist roll with the funds.



FORT PIERCE, Florida, Lodge provided information about and transportation to the Elks' Harry-Anna Crippled Children's Hospital in Umatilla for David Hill (center) and his mother Carol Hill. ER Paul Testa (right) drove the Hills to Umatilla via transportation donated by Nash-Pontiac-Cadillac, Inc.



PDD JAMES COLBERT SR. (center), a past GL Committeeman, of Somerville, MA, Lodge traveled to Portsmouth, NH, Lodge, where he installed his son James L. Jr. (right) as Exalted Ruler and his grandson James F. as Inner Guard. James Sr. offered his congratulations to the two new officers following the ceremony.



A CONTRIBUTION of \$2,500 to the state major project was made by Torrington, CT, Lodge in fulfillment of their annual pledge to the Newington Children's Hospital. Then-ER Gordon Benedict (third from right) passed the check to State Major Projects Chm. Jack Goodman (fourth), while (from left) John Heffernan, lodge Chm. Mario Teti, DDGER John Kuzmak, and VP Joseph Palmer expressed their thanks to the Torrington Brothers.

The Home's Jubilee Anniversary

Two days of pageantry at the Elks National Home in Bedford, VA, commemorated the Home's 75 years of existence. Hostesses in old-fashioned, colorful hoop skirts welcomed the Elks and their guests, who arrived from across the country to join in the festivities, which included happy birthday speeches, a grand ball, and a barbecue. One of the special guests, PGER John Walker (top photo, right), addressed the celebrants who attended the Saturday evening formal ball and introduced Virginia's Governor John Dalton (left). The governor extended his greetings to those in attendance.

From the main portico on Sunday afternoon, then-GER Homer Huhn, Jr. (top left photo) addressed those assembled on the lawn of the Home: "The providing of a Home for our retired members started as a small operation, but everyone involved knew that this humble beginning would someday grow into a great asset to our Order and a 'Home Away From Home' for our members." Brother Huhn spoke of the origin of the Home, its growth, and its possibilities for the future, commenting that, "A great heritage has been left to us, the living, by those great men who preceded us. It now becomes our responsibility to accept that heritage and do all in our power to improve upon it in order that they who follow us will inherit a greater heritage."

One of the highlights of the afternoon ceremony was the presentation of an original oil painting commissioned by

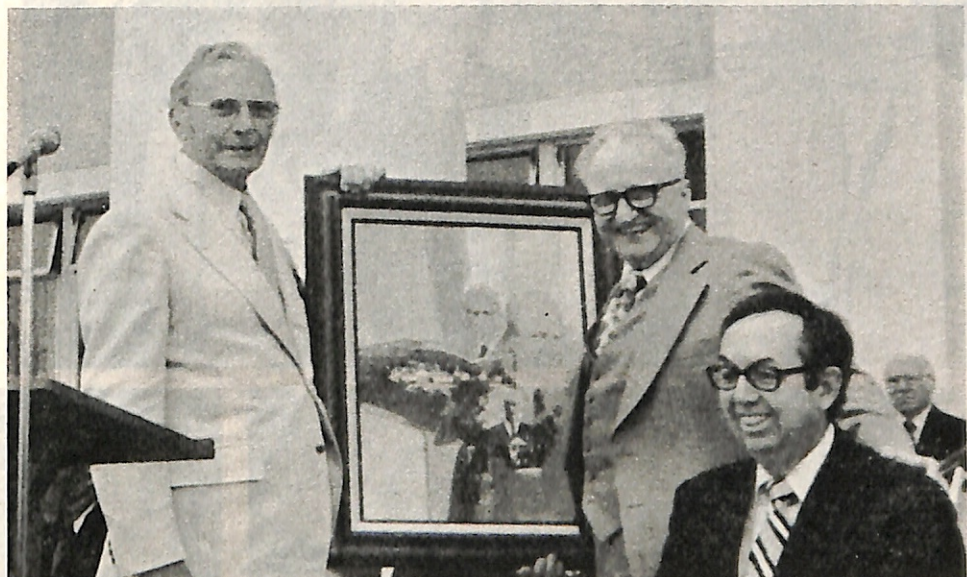
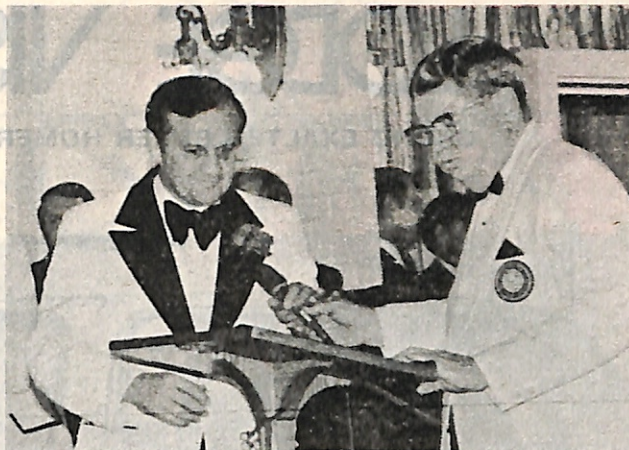

Then-GER Homer Huhn, Jr. delivered his speech.
PGER John Walker introduced Governor Dalton.
PGER Edward McCabe and Director Irvin displayed the painting.

The Elks Magazine [cover, May, 1978] from artist Richard Mlodock. Congressman Caldwell Butler (bottom photo, right) admired the artwork displayed by PGER Edward McCabe (center), treasurer of the Elks National Memorial and Publication Commission, and

the Home's Executive Director Doral Irvin. The anniversary party concluded with a barbecue, where the Brothers and guests consumed a hearty meal before bidding one more congratulatory wish to the National Home upon its diamond jubilee.



THE HELWIG family constituted 10 percent of a 50-member class initiated recently by Troy, NY, Lodge. Following the ceremony, Albert H. Helwig (left), his sons Albert M. (second from left) and David (fourth), and grandsons Robert A. (fifth) and Robert R. (sixth) were welcomed to the order by ER Ralph Alcombricht.



A DONATION of \$5,000 to aid the fight against cerebral palsy was presented by New Hyde Park, NY, Elks to Southeast District Major Projects Chm. Nilo Mengrome (second from left). Immediate PER Bill Kucich (second from right) proffered the check, while PER James Ciringione (left) and ER Gus Graffeo observed. New York Elks help support the United CP Association's Home Service Program.

LODGE VISITS

GRAND EXALTED RULER HOMER HUHN, JR.



On hand for the Tennessee Elks' recent state convention were 703 Brothers who were honored by the presence of GER Homer Huhn, Jr. (third from left), PGER Horace Wisely (fourth), and PGER Edward McCabe (second), state sponsor. Official greetings were extended by (from left) GL Committeeman Ted Callicott, immediate PSP Harry Lester, and immediate PER Billy Vaughan of Nashville Lodge, the convention host lodge.

Approximately 300 Brothers from the state of Arkansas attended a gathering at Hot Springs Lodge, where the GER was the guest of honor. SP Maurice Bell (right) and ER Dennis Chapman (left) welcomed GER Homer Huhn, Jr. to the Land of Opportunity.



Sharing a lunch break during a meeting at Ogden Lodge were Utah Elks SP Ralph Bogar (seated, right) and SDGER Alton Thompson (seated, second from left) and guests PGER Robert Boney (seated, left), state sponsor, and GER Homer Huhn, Jr. Brother Huhn was presented with a 50 caliber black powder rifle on behalf of Utah Elks.



The history of Charleston, SC, was the topic of conversation as GER Homer Huhn, Jr. (left) toured that city with PGER Robert Pruitt (third from left) and their local hosts. Charleston Lodge PER Edward Lofton (second from left) and (from right) DDGER Michael McKain, Est. Lead. Kt. W. Howard Walker, and SP A. Herman Schwacke listened as the GER recalled lessons learned about the early days of Charleston.

■ Alan Garinger spent most of his life teaching Johnny to read. Then he discovered Johnny's parents couldn't read either. That's when he and other school officials in Muncie, IN, decided to do something to help the more than 2000 illiterate people—most of them adults—in the area learn the most functional thing in their lives—to read. The answer is a ring-a-ding-ding reading lesson.

Using an innovative concept which allows the non-reader to merely pick up a telephone and dial a number, the project may indeed spread nationwide. It's popular in that it permits the ultimate in anonymity for the caller; no one ever has to know he cannot read. Garinger, director of Adult Continuing Education for the Muncie Community schools, became aware of the need for such a program in early 1973, but it was some time before all the details could be worked out and the project implemented.

"We never really knew exactly how many illiterates we had in this community," said Garinger, "but we began to discover them with increasing frequency. And we estimated there were more than 2000 in the area. It was difficult to come up with a firm figure, for so many people would not even let their closest friends know they could not read and write."

That's the reason the program has had such great success since it was begun in 1974. Any individual wishing to take lessons in reading on his own level need only dial 747-1235. The phone is answered by a voice on a recorder. No questions are asked. The caller does not identify himself. But the lesson is given in five- to 10-minute sessions. If the caller does not understand or needs to take the lesson over again, he can merely redial the number for a repeat.

The program was so popular from the outset that the heavy load of calls broke down the equipment. And subsequently, Garinger and his colleagues have met people who admitted they used the system and either learned to read or greatly improved their reading skills from it. Hundreds of calls are made to the reading number—Garinger installed a counter on the recorder system—each month, most of them during the evening hours or on weekends. But the student can call at anytime, 24 hours a day, seven days a week.

The "reading number" is publicized by a variety of means, but most importantly through the grapevine system. Garinger made door-to-door calls in the community, talking with people. We

wanted people to start talking about the program in their own neighborhoods, to know it was available. It was that personal contact that made the difference. The word was passed on from person to person.

"It's confidence in people at the grass-roots level that made me know from nearly the beginning that this program would work," said Garinger. "And when we saw the grapevine begin to work, we knew even more so our program was going to work."

Even so, it still hinged to a great extent on getting the people to pick up the worksheets. So those were distributed to various locations around town—a neighborhood grocery, a local bar, the pool hall, a beauty or barber shop. One of the locations was Bob Cunningham's Red Front Market. Cunningham himself became convinced it was a good program and took a personal interest in getting people to pick up the worksheets. He later became mayor.

by Bill Thomas

Telephone Teaching





In addition, radio and TV stations publicized the program. And the people heard and understood. Within a few weeks, the calls were pouring in. The initial battle had been won. Now the worthiness of the program was at stake. Would it work?

A lot depended on the worksheet. On the back of each worksheet, in large figures, is the number to dial. But the single thing that made it workable and understandable to the non-reader was that the worksheet is color coded. Using basic colors of red, blue or green (if the student suffers from color-blindness, he may have to seek the help of a friend or member of his family), the worksheet thus helps the student to find the words of the day's lesson.

Garinger himself writes most of the stories used in the reading program. Woven around adult themes on subjects common to everyday life in that particular community—getting a job, social services, farming, consumer education—but on a level that is simple and easy to understand. They are appealing and interesting, and all are written, of course, around two groups of coded words. Initially, Garinger hired professional people—local radio announcers, people good in public speaking and

voice delivery—to do all the recording. "This proved to be the single most expensive part of the program," he said, "so we started doing some of that with our own people. My daughter even does some of it. Anyone who has a pleasant voice and can read well could do it."

The word list which the stories use in teaching was made up by Dr. Dale Johnson of the University of Wisconsin, an internationally recognized authority on reading skills. His word list is broken down into five colors with nine groups of six words for each color.

When Garinger first conceived the idea, he discussed it with his friends at the Adult Education Center. And then he talked with his superiors about it. Some of them were impressed. The County School Superintendent was not among them. He said it wouldn't work and that the idea ought to be dropped. Garinger didn't think so; neither did his immediate supervisor, Don Whitehead. Together, they decided to go ahead with the project anyway.

"It was this kind of hard-headed insubordination that made it work," chuckled Garinger. "And a success," Whitehead added.

There were others who thought it was a hair-brained idea. "When some people heard about the program," Garinger recalled, "their reaction was that you can't teach a person to read by

phone. Reading, they contended, was a visual thing, and they would be using only their ears. But we found that listening for a certain word was not much different than seeing that word. With our worksheet we were able to direct them to look at a specific word. It is a word they can find because it's color coded. This makes it a visual experience for them on their end of the phone line," he explained.

The phone call-in reading program is not the total answer, however, nor was it intended to be. The purpose of the call-in project was to permit the people to take an interest and to gain some self-confidence, to get a feel for reading. True, they could learn much about reading, even how to read. But school officials hoped this would be merely the first step on a journey leading to a richer existence.

To further implement the program, Neighborhood Initiation Centers had already been set up by the Adult Education Department as "halfway houses." Again, these were in business places where people of the community would be likely to go. Operators of the business places were also trained by visiting teachers to become para-professional teachers themselves. They were given in-service training in order to develop ideas, understandings and simple tech-

(Continued on page 28)



THE JOY OF GIVING

Elks National Foundation
2750 Lakeview Avenue • Chicago, Illinois 60614



Ronald Campbell, Foundation chairman, presented a pin and certificate to Elks' ladies past Pres. Elizabeth Duclos in recognition of the completion of her payment for membership in the National Foundation. Brother Campbell made the presentation during a gathering of Enfield, CT, Lodge Brothers and the ladies.

During a recent awards night at Torrance, CA, Lodge, Chm. and PER Fred Mishler (left) presented a certificate to Penny Cid (center) in recognition of her generous contribution to the Foundation. Immediate PER Armando Cid was on hand to congratulate his wife and to join her in congratulating Brother Mishler for helping the lodge achieve the distinction of being the number one fund raiser in the South Central Coast District.



A plaque acknowledging Boca Raton, FL, Lodge's support of the National Foundation was presented by DDGER Steven Merena (left) to then-ER Lester Yam. During the past lodge year, the Boca Raton Brothers were responsible for 73 new memberships.



IT'S YOUR BUSINESS

by John C. Behrens

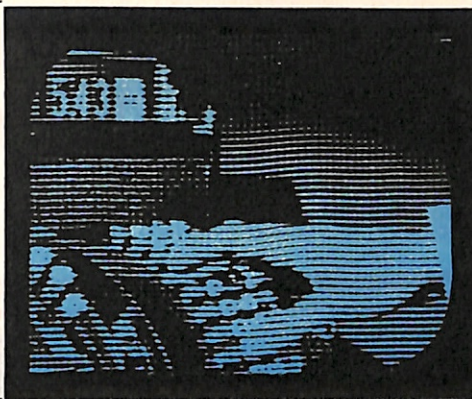

DOG DAY REFLECTIONS

"I've got some good news and some bad . . . which do you want first?" That's how an army buddy used to taunt me as I got closer to my ETS date and the end of my tour of duty in Korea. I knew most of it was bad. It figured. He still had 6 more months to go and misery, under those circumstances, always relished company.

For example, he'd tell me that word from some personnel officer somewhere was that the army transport scheduled to take me stateside would be delayed. Sometimes it sank. Once it was cancelled. Another favorite story was that tension elsewhere in the world diverted it to pick up marines and take them to battle stations. (Ironically, he was right on that score: I was pulled off the *USS Breckenridge* in 1958 when it was thought the ship would have to take marines from Okinawa to Lebanon.)

The good news? There would be hamburgers instead of fish at chow that night.

The analogy may fit the American businessman as he enters the final days of summer, 1978.

The problem, I find, is deciphering what you read and hear.

For instance, Jimmy Carter's chief economic adviser, Robert S. Strauss, spent the early part of the summer telling businessmen they must accept smaller price increases if labor cooperates by demanding smaller wage boosts. "Business knows they are going to have to step forward first and that they will have a very, very salutary effect on labor negotiations . . ." Strauss said. Vice President Mondale picked up on the same theme later with a carrot-and-stick message. Patriotism of business and labor, he noted, will be a factor in the Carter Administration's anti-inflationary drive. He warned that the federal government "will not hesitate to bring unselfish actions . . . before the court of public opinion."

Unfortunately, the tough talk about restraint came too late to influence major collective bargaining settlements in the first quarter of the year.

At the same time, readers of major daily business pages were treated to some surprisingly good news. Unless something "unforeseen" occurred, said the *New York Times*, the second quarter should be a boom period. Private and government forecasters suggested that the American economy could grow between 6.5 and 10 percent in real, non-

inflationary terms during this period.

Meanwhile, back at the fed, the Federal Housing and Veterans Administrations announced their mortgage rates would be 9 percent, the highest in 2½ years. "This change is expected to increase the availability in FHA financing for moderate income home buyers and sellers who are the major beneficiaries of FHA-insured mortgage financing," said Patricia Roberts Harris, secretary of housing and urban development. Government officials, some said, were reacting to pressure from bankers, like those in New York, who insisted that the home mortgage money would dry up if there was no relief.

But economists aren't convinced such increases and jawboning will help [read June "It's Your Business"]. In 1977, construction industry experts predicted that residential construction would fall off this year. Housing starts, however, rose by 6 percent in April. Higher interest rates now, industry sources say, will halt growth.

"We are expecting to have the highest mortgage interest rates since the Depression by the late fall. I hope they don't reach 10 percent but if they do, we're finished," said a representative of the National Association of Home Builders.

Other developments have disheartened

and confused proprietors this summer, too. The U.S. Postal Service, which might be improved if it was denationalized, raised its rates again after months of conflicting stories about cost reductions, service cutbacks and speculation on postal increases. At the same time, the system's restrictions and procedures are still a source of irritation to business people. For example, there is still some confusion over what type of tape is reinforced and what isn't, whether or not twine can be used on all packages and why some magazines continue to show up in the mailbox mutilated.

But all is not doom and gloom either. The Supreme Court, for example, decided that the Occupational Safety and Health Agency which businessmen have insisted harrassed them with unannounced inspections cannot enter a workplace without a proper warrant. The court informed the agency that its 1300 field inspectors must use traditional legal procedures to search a business premise. Overzealous inspectors, many business owners contended, made the 1970 Occupational Safety and Health Act more of a threat to a business's existence than the safety hazards they discovered.

Finally, two groups of business experts and analysts came to similar but independent conclusions about what's ahead for proprietors this year and next . . . and both were optimistic. The Business Council and Eggert Economic Enterprises concurred that real economic growth for the year would be about 4.3 percent and 3.6 percent next year. Consumer prices will probably reach 6.4 percent increase this year and 6.6 percent in 1979. Unemployment, meantime, will probably stay around 6.2 percent during the next 24 months.

Of course, all of this depends upon how you decipher what's said.

Still sounds to me like hamburgers instead of fish, though.

Address your comments and questions to John Behrens, c/o The Elks Magazine, 425 Diversey Parkway, Chicago, Illinois 60614.

FIND BURIED TREASURE

Find buried gold, silver, coins, treasures with powerful new electronic detector. Ultra sensitive. Penetrates deep into earth. Works through mud, beach sand, rock, wood, etc. Signals when object is detected.



Write for Free Catalog, treasure hunting tips and unusual souvenir coin.

RELCO Dept. DD29, Box 10839, Houston, Tex. 77018

Financing Available



NEW FOR THE ELKS MAN

These beautifully hand-crafted pieces of Elk styled jewelry will make a handsome gift, or buy it for yourself, you deserve it. All pieces are unconditionally guaranteed against breakage.

Watch band, belt buckle and bolo tie are available in silver plate or gold plate; your choice at one low price.

Watch band—\$19.95, Belt buckle—\$16.95, Bolo tie—\$12.95. Price includes shipping and handling. Please allow up to 3 weeks delivery time from date order is placed.

When ordering, be sure to specify gold or silver. To order thru:

BankAmericard VISA Master Charge (check one)

Fill in card numbers & expiration date below. date

Send all orders to J & L Enterprises, P.O. Box 486, Montebello, CA 90640, (213) 724-6407.



Lover's Guide to

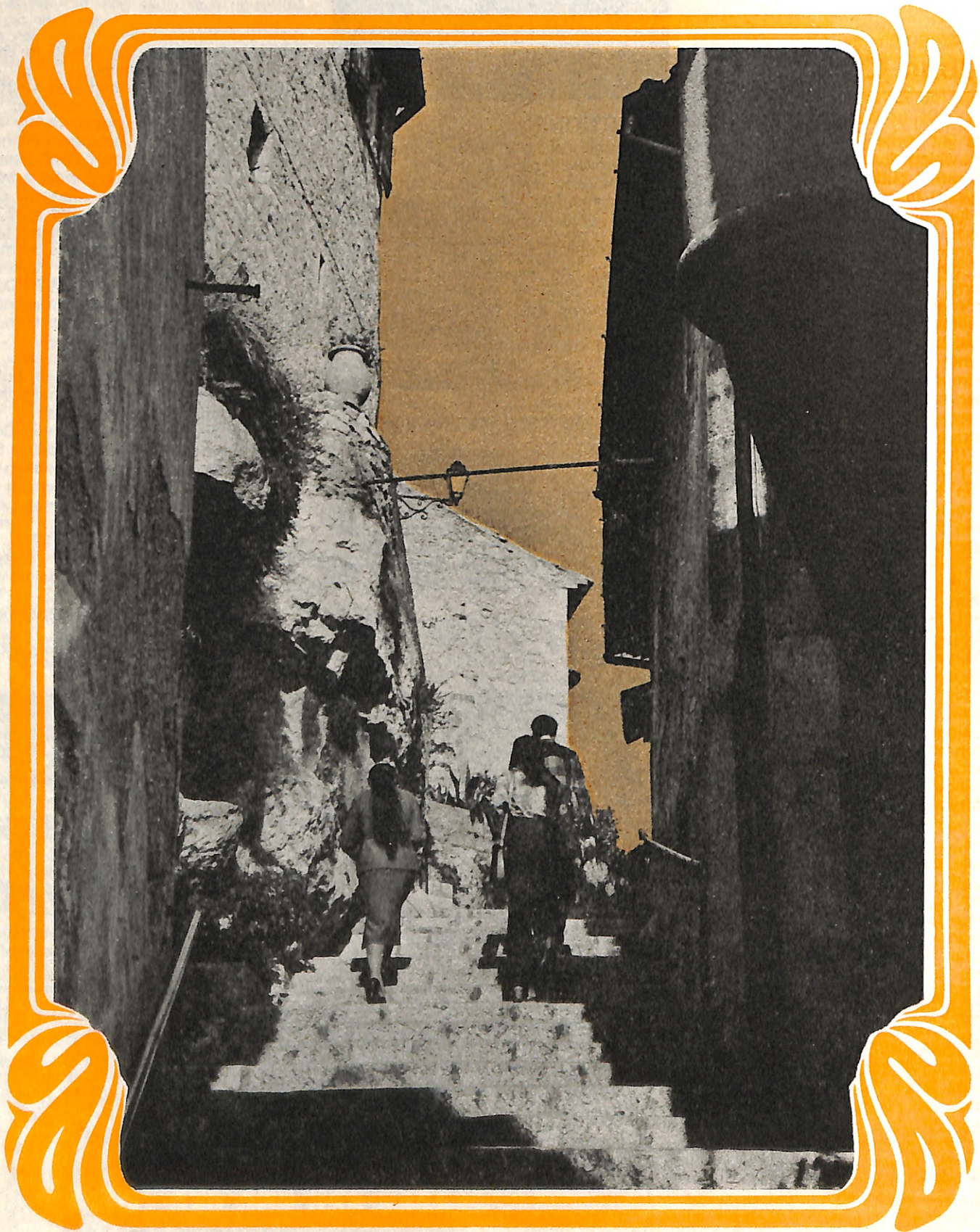

The medieval steps of Eze lead to a spectacular view of the entire French Riviera.

the Riviera

by Jerry Hulse

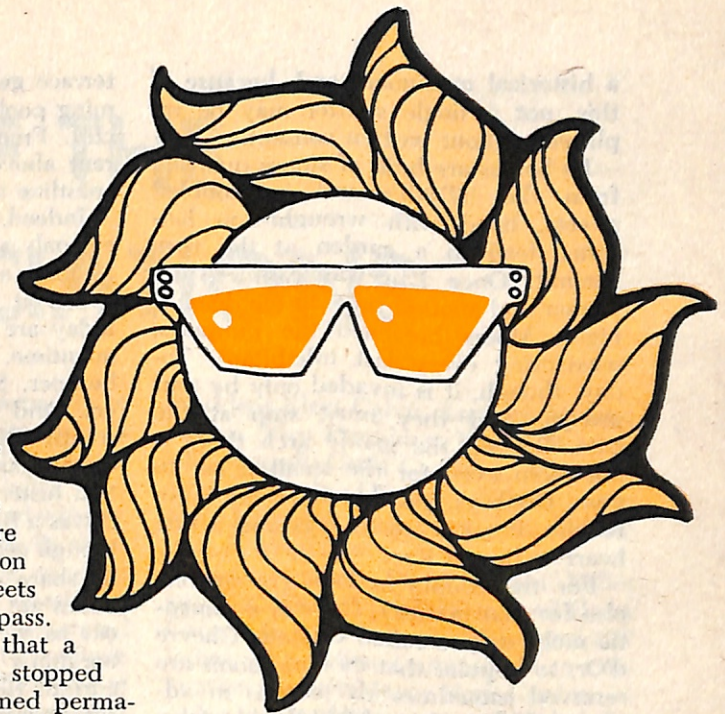

Get out the scissors and the scrapbook: With cupid in the wings, this month we are bringing you our *Lover's Guide to the French Riviera*. Beginning with Eze—which is next door to Nice—our tour takes in villages from Cap Ferrat to the lovely hill town of St. Paul de Vence. To qualify for the trip one need only confess to the weakness of being a romantic. Perhaps it's best, though, to keep Eze for later in this story; the dream truly ends there—for Eze is like the final chapter in a storybook romance, an experience that sets off the siren in one's very soul.

In that case we will skip ahead to one of the hill towns behind Nice and work our way back along the coast to this romantic village. Primarily our guide deals with historical inns and small hotels, and so with this in mind our tour begins at Le Colombe d'Or, the ancient inn at St. Paul de Vence. During its long history Le Colombe d'Or has offered shelter to a host of notables, including the Duke of Windsor, Sir Winston Churchill and Yves Montand. These and dozens of others. Le Colombe d'Or, many will argue, is the centerpiece of St. Paul de Vence. A century old inn, its walls are hung with priceless paintings signed by such masters as Utrillo, Derain, Bonnard, Matisse, Picasso and Chagall.

There is a courtyard where luncheon is served on Sundays (as well as on warm summer evenings) and exposed against one wall is the first mural ever displayed publicly by Fernand Leger. In the same courtyard a wooden bucket hangs over a well—only instead of water, it is filled with fresh flowers. Le Colombe d'Or is a museum, a museum that is alive with romance. The bar (it is barely bigger than a child's playhouse) features window seats, and it is here that guests relax while tables are prepared in a dining room whose menu corrupts both mind and body.

Rooms in this ancient inn are reached by a staircase between the bar and restaurant. Some feature canopied beds. Each is restful and romantic. It goes without saying that such atmosphere doesn't come cheap. A single with breakfast will cost you roughly \$45 (why, though, come to Le Colombe d'Or alone?) or a double is priced at \$58. Add to this a 15 percent tax and it figures out to a tidy sum.

St. Paul de Vence was founded by the Ligurians and later invaded by the Phoenicians and the Romans. A cannon guards one entrance and its houses are crowded together so closely on either side of the narrow streets that only a motor bike can pass. So enchanting is St. Paul that a former New York politician stopped one day for tea and remained permanently to paint.

In the old walled village a French woman with stringy red hair and the spirit of a patriot operates a two-room inn, the Hostellerie de la Fontaine; guests gather in a small three-stool bar or, whenever the weather is pleasant, they repair outside to a terrace overlooking a narrow, cobbled street and a fountain as old as the village itself. The proprietress describes her inn as "tres antique" although her own spirit is as young and as fresh as the flowers that bloom beyond her door. It is not elegant, this inn beside the fountain. But if you are young and the blood runs hot and you are in love, well, I think it would do nicely. Besides, \$13 a night for the best of the two rooms isn't a bad deal at all.

Not far from St. Paul, in the 13th century walled village of Haut-de-Cagne, the Hotel Le Cagnard offers similar old-world atmosphere at \$24 a night single or \$33 for a double, and close by overlooking Vence and the Mediterranean, Chateau St. Martin is another candidate in this *Lover's Guide* to the French Riviera. Rising at the site of a 15th century castle, Chateau St. Martin is a luxury establishment with 15 rooms plus five villas (for those desiring complete privacy).

As a hideaway for lovers, Chateau St. Martin features a heart-shaped swimming pool plus rooms without numbers. Instead of numbers, the rooms are named for life's romantic events and episodes. Example: Carpe Diem, the title of a poem which suggests that one live each day individually, without fretting over tomorrow.

Other rooms at Chateau St. Martin are reached by a marble staircase. Spotless hallways are lined with bowls of blood-red roses and gladiolus and priceless antiques, and outside on the terrace, where meals are served in sum-

mer-time, there are splendid views of the terraced hillsides and the old walled city of Vence and the distant Mediterranean. Such atmosphere is expensive, of course. A couple in love will pay a minimum of \$110 a day plus 15 percent service, even in the low season. Rates in the high season are roughly 20 percent more and a villa is apt to cost the starry-eyed couple up to \$200 a day. It's enough to cool the love affair!

And then there is Cap Ferrat which juts into the Mediterranean a few miles outside Nice. The village is a small crescent at the water's edge and windows at Hotel Voile d'Or frame the entire scene: yachts and small fishing boats, the buildings with their red-tiled roofs and yellow shutters and geraniums flowing from window boxes. Each morning the village is awakened by church bells. Set serenely in the center of Cap Ferrat is a square, and it is here that an old flower peddler sits surrounded by her roses. They are piled high beside her. She recalls once, several years ago, when a stranger purchased an entire armful and then rushed away, apparently to the woman he loved.

Cap Ferrat is loveliest at sunset, though, when the sea is drained of its brilliance and the lights of villas begin to twinkle on along the distant hillside and romantics, arms locked together, sit in the square looking up at the stars.

But I said earlier that the dream truly ends at Eze, a medieval village rising on a hilltop midway between Nice and Monte Carlo, an eagle's nest that provides the most spectacular view along the entire French Riviera. From Eze one looks straight down 1300 feet to the Mediterranean and its coastal towns in either direction. On a clear day, in fact, one can see all the way to Corsica. The village is a dream, with narrow, winding streets and steep stairways and walls heaped with bougainvillea. Eze is

a historical monument and, because of this, not a single shutter may be replaced without written consent.

Its homes are built of stones quarried from the hillsides and its cobbled streets, lined with wrought-iron lanterns, lead to a garden at the very summit. Once Eze was captured by Caesar and another time, in the dead of night, Moors breached the ramparts, massacring every last inhabitant. Today, though, it is invaded only by tour groups. And they must stop at the gate. Beyond the gentle arch there is not room even for the smallest car to pass. Donkeys, yes, but never an automobile. It takes sturdy legs and a fine heart to live in Eze.

For the couple in love (or anyone else for that matter), there is a romantic niche at Eze called Chateau Chevre d'Or, so popular that its nine rooms are reserved sometimes six months in advance (\$32 single and \$42 double—plus service and taxes). Originally a private villa, the Chateau was damaged during World War II, after which it was rebuilt by a musician from the opera at Monte Carlo. Each of the rooms has a private entrance that leads to the street. What is now the bar was once the music room, and where the bar itself stands there was a piano. To set the proper mood, candles flame and a wood fire is lit whenever the night is cool. On the

terrace guests sunbathe beside a swimming pool that braces itself against the cliff. From here—and from the restaurant above—the view takes in miles of coastline along the French Riviera.

Indeed, Monte Carlo is in sharp focus only a few kilometers away. And so as long as it's this close, one should spend at least a day there. Its streets today are as crowded as New York at noontime. Traffic moves bumper to bumper. Shops overflow with customers. And the cash registers ring constantly. Nevertheless, it's exciting, it's extravagant, it's tempting. True, a certain luster has been lost. Not everyone drives a Rolls or a Bentley anymore (although certainly Monaco has more than its share of limousines). Now the avenues are crowded with VWs and Simcas as well as the Ferraris and Lamborghinis driven by former kings and current film stars. The blue blood still congregates in Monaco. But so do tour groups from Tokyo and Texas whose draws are heard up and down Boulevard des Moulins.

Prince Rainier's principality involves barely 500 acres, an area roughly half the size of Central Park. Nevertheless, each day at noon the Carillon announces the changing of the guard. While one small platoon marches in, another marches out—representing the entire military establishment of this

lively little storybook kingdom in which no one is drafted, no one pays income taxes, the budget is balanced and unemployment is non-existent.

Monte Carlo is famous, of course, for Princess Grace and the grand old casino which faces gardens smothered with flowers; they bloom all the way from the entrance to Avenue de la Costa and Boulevard des Moulins. Unfortunately, it's all about as lively as a Russian wake. The action's next door in the Las Vegas-style casino operated by Loews, the new 637-room hotel built on land reclaimed from the sea. It is difficult indeed to determine if one is actually in Monte Carlo or Caesar's Palace. It's noisy; it's exciting; it's informal. What's more, the Europeans love it. Not only are Americans fond of the hotel, but Europeans seem to take to Loews, as well. Gaming tables operate from one o'clock in the afternoon till five o'clock the next morning. And they'll continue the rest of the day should there be a high roller.

While no one has ever broken the bank at Loews, occasionally they've come close to it. One guest walked away with a tidy \$150,000 one night recently. Another who returns three or four times a year is richer to date by more than \$300,000.

Try that in Las Vegas or Atlantic City. ■

ELKS NATIONAL SERVICE COMMISSION

"So long as there is a disabled veteran in our hospitals, the Benevolent and Protective Order of Elks will never forget him."



A large package of underclothing was recently presented by North Palm Beach, FL, Elks to the Miami Veterans Hospital. Beulah Meyers, veterans service volunteer, accepted the items which were worth \$350 from Vets Chm. John Busby (center), while Tom Dorthery, VA director, joined Ms. Meyers in expressing the hospital's gratitude.



A dinner followed by an evening of entertainment at Point Pleasant, NJ, Lodge was enjoyed by disabled veterans from the Crest Manor Rest Center. Gathered around a table in the lodge's newly renovated grill room were three of the guests who chatted with (standing, from left) PER George Duffy, Nancy Fiore, Center supervisor, and Vets Chm. Ray Smalling.



Rehabilitation and recreation items valued at over \$1,350 were donated to the Clarksburg VA Hospital recently by PER Dave Collins (left), VP W. C. DeWeese (second from left), Vets Chm. Fred Lang (fifth), and DDGER James Carpenter (sixth) on behalf of Morgantown, WV, Lodge. (From right) F. J. Barberio, hospital volunteer officer, John Cox, hospital director, and Dr. Carl Dahlen, chief of staff, were on hand to thank the Elks for the gifts, which included books, playing cards, chess sets, and a punching bag.

NEWS OF THE STATE ASSOCIATIONS

Las Cruces was the site of the April 13-15 annual meeting of the New Mexico Elks Association. Then-GER Homer and Jo Huhn, PGER Edward and Maggie McCabe, PGER Robert Boney, and GL Committeeman Howard and Dot Nunez were among the approximately 325 Elks and 280 ladies in attendance. Among the new state officers was SP Greeley Myers of Las Cruces Lodge, who was congratulated by his father-in-law PGER Boney [see "Lodge Visits," July, 1978, *The Elks Magazine*].

Assisting Brother Myers for the 1978-1979 year will be Vice Presidents Willis Claus, Albuquerque; Earl Phillips Jr., Roswell; Secy. Howard Nunez, Albuquerque; and Treas. E. H. Jahraus, Albuquerque. The ritualistic contest was won by Albuquerque Lodge, with the Farmington team taking second place, and Carlsbad Lodge capturing third. During the business session, delegates adopted a by-laws amendment designating the immediate PER of each lodge a delegate to the state association.

The Cerebral Palsy Commission, representing the state's major project, submitted a budget of \$127,000 for the coming year. Faculty members of the

Speech and Hearing Department of New Mexico State University gave a slide presentation which explained how the Elks' money for CP was being used at the school to aid handicapped persons. Miss Janice Orsak thanked the Brothers for the financial assistance she received from the state association's charitable and benevolent trust fund. She stated that the aid has enabled her to continue her college education with the goal of working with speech handicapped children.

Saturday evening 450 of the delegates and ladies attended a formal banquet, during which they put business matters aside and enjoyed themselves. Then-GER Huhn was the principal speaker for the affair.

New Mexico Elks plan on reconvening for a fall meeting on October 20-21 in Santa Fe, and will hold their 1979 convention in Albuquerque from April 19 through 21.

The new leaders of the Iowa Elks Association were installed during the May 5-7 convention held in Fort Dodge. SP Darwin Hammer will share the responsibilities of Iowa Elkdom with

President-Elect Calvin Knop of Atlantic Lodge; Vice Presidents Henry Schoen-jahn, Carroll; Craig Caslavka, Waterloo; Verne Jarvela, Grinnell; Edward Stoline, Jefferson; and Secy. Leo Youngblut of Waterloo.

Special guests PGER Glenn Miller and SDGERs Wendell White and Harry Carney Jr. joined the 264 Elks and 227 ladies who listened attentively to convention speaker Mayor Herb Conlon.

No exact dates were scheduled for future gatherings of the Iowa Elks, but there will be a fall, 1978, meeting in Des Moines, and the annual convention will be held in Sioux City, Iowa, during May, 1979.

Then-Grand Est. Lead. Kt. and State Treas. Hal Randall was inducted into the Oregon Elks Hall of Fame during the May 4-6 convention which took place at Seaside, OR. Dignitaries who were present to witness the event included PGERs Frank Hise, state sponsor, and Raymond Dobson, SDGER Robert Tancredi, Idaho's then-SP James Lynn Jr. and Secy. Ronald Caritone, GL Committeeman B. J. Bybee, Washington's outgoing SP Ivan Harlan, President-Elect C. J. Hauge, and Bernard Chillquist, Washington's state assistant sergeant at arms.

The reports on major charitable activities included a tally of the funds dispensed during the past year. Of a total of \$71,566.39 in contributions, \$46,073.39 went to the state major project, the Oregon Elks Children's Eye Clinic. The National Foundation received \$6,200 and a program for the physically handicapped received \$19,293.

SP Bruce Reed of Beaverton Lodge will be directing the state association with Vice Presidents Dick Herndobler, Ashland; Jack Sweek, Pendleton; Norman Polley, Ontario; Loyd Peterson, Florence; F. Braatz, Eugene; Don Stephens, Lake Oswego; Berton McVay, Oregon City; Secy. Orville Mull, Keizer; and Treas. Hal Randall, Salem. The mid-winter meeting will be held in Springfield on January 18-20, 1979, and the next annual gathering was scheduled for May 3-5 at Klamath Falls.

There were 2,232 people participating in this year's three-day meeting at Seaside.



Freddie Covington (left) of Las Cruces, NM, Lodge received the state's Elk of the Year plaque from outgoing SP Ike Alarid during the New Mexico Elks convention. The award was given to Brother Covington in recognition of his outstanding efforts on behalf of the National Foundation.

Telephone Teaching

(Continued from page 22)

niques for teaching reading. Their working place served as a classroom.

The goals of these centers were to help individual students achieve a feeling of success, to promote interest in continuing the educational process and to impart learning in areas where it was most needed.

"The centers themselves might have accomplished the reading program even better than the telephone except for one thing. It gets right back to the anonymous thing again. A lot of people are just too shy to let it be known they cannot read or write," said Whitehead.

Officials of the educational system at Muncie are now so impressed by the system that it's being expanded to other subjects. Math is on the curriculum. Conversion to the metric system is one of the courses being offered. And Gar-

inger believes it will prove to be as popular, maybe more so, than reading.

Teaching by telephone is also being used in a few other places, among them the University of Wisconsin. The university's agricultural extension service began a program offering courses by telephone tape on such diverse subjects as house plants, vegetable growing, lawn care, canning, freezing, removing spots and stains and other program areas. The tapes run from two to four minutes, and university officials claim it has proven most popular in the rural counties which were chosen for the pilot program.

But Garinger feels nothing could be more important in the phone teaching program than learning to read. It's a plight that reaches deep into the American public. More than 23-million Americans can't understand the printed word, and a very high percentage of those cannot read at all. The U.S. Of-

fice of Education in Washington released figures showing that millions of people aged 16 and up are functionally illiterate. They can't read a help-wanted ad, can't fill out forms for a driver's license or Social Security, can't understand the directions on a bottle of medicine, can't read a bedtime story to their children.

Take the case of a Minnesota mother distraught because "my little girl has started to bring home books from school and asks me to read them to her . . . and I can't." Of the 40-year-old maintenance man who wanted all his life to be a truck driver but could not read maps or road signs. Of the Colorado woman who bought dog food for her family, thinking it was meant for human consumption.

How could anyone graduate from high school and still not know how to read? Appalling, you might say. But Garinger contends that in today's lax school system in this country, a student can go through school and pass every subject either by bluffing his way through or cheating.

The Muncie effort is not the only one in the country which attempts to combat the illiteracy problem. Several exist, some of them very effective, but as far as Garinger knows there aren't any others using the telephone to do it.

In the Chicago suburb of Evanston, for instance, a community-based group rented two rooms on the corner of a well-mixed black-white neighborhood. Students, tutors and even the project director, Prof. Sidney Bergquist of Northwestern University's School of Education, pitched in to paint, panel and build bookcases. Donors contributed thousands of books and magazines.

A onetime school dropout—Hecky Powell—was hired as community liaison. He scoured Evanston, much of it on foot, in search of students, carrying the message: "Hey, man, I really pulled my life together by reading. You can, too." More than 300 persons responded.

Just how successful the Muncie program has been is difficult to evaluate. More than 4000 hours of reading lessons have been delivered by the system (which incidentally, Garinger says, cost less than \$500 for equipment). And enrollment in the Basic Adult Education classes has more than doubled. "Many of these people, we feel," said Garinger, "are the ones that were dialing into our phone program."

The program has created new avenues of thought in the education field. Just how far it reaches may be unmeasurable, but there's little question that many people in the Muncie area that were illiterate just five years ago can now read. That fact in itself is a most heartwarming testimonial to Muncie's educational efforts. ■

Veterans Remembrance Month Brochure Contest Winners

The following lodges have been judged winners in the 1977-1978 Veterans Remembrance Month Brochure Contest, also known as Grand Lodge Contest "C." The brochures were chosen from among the entries submitted to Peter T. Affatato, a member

of the GL Lodge Activities Committee. All entrants may pick up their brochures at the exhibit staffed by the Committee at the GL Convention in San Diego, July 16-20. No brochures will be returned by this Committee following the convention.

Lodges through 300 members

1. Raleigh, NC, Lodge
2. Greenville, TX, Lodge
3. San Juan, PR, Lodge

601 through 1,000 members

1. Weymouth, MA, Lodge
2. Passaic Valley, NJ, Lodge
3. Winslow, AZ, Lodge

1,001 through 2,000 members

1. Sterling, CO, Lodge
2. Grand Rapids, MI, Lodge
3. Anderson, IN, Lodge

301 through 600 members

1. Smithfield, RI, Lodge
2. Schenectady, NY, Lodge
3. Dover, NH, Lodge

2,001 or more members

1. San Jose, CA, Lodge
2. San Mateo, CA, Lodge
3. Olympia, WA, Lodge

Excellence of Public Image Contest 1977-1978

The winners of the 1977-78 Public Image Contest have been chosen from entries received by James Kenney, a member of the GL Lodge Activities Committee. The contest has revealed many and varied community service

programs conducted by the lodges during the year which have improved the image of Elksdom in the eyes of the community. The top three winners in each of the five membership divisions are listed here:

Lodges through 300 members

1. Ocean Springs, MS, Lodge
ER Al Auge
2. Williams, AZ, Lodge
ER Richard Carpenter
3. (none—only two entries in this class)

301 through 600 members

1. Slidell, LA, Lodge
ER William Wallen
2. Lake Havasu City, AZ, Lodge
ER J. Sherman Husser
3. Westchester, CA, Lodge
ER John McGah

601 through 1,000 members

1. Winslow, AZ, Lodge
ER James Ellis

2. Oceano/Five Cities, CA, Lodge
ER Henry Mann
3. Elwood, IN, Lodge
ER George Acres

1,001 through 2,000 members

1. Anderson, IN, Lodge
ER Richard Townsend
2. Sterling, CO, Lodge
ER Gary Harms
3. Westbrook, CT, Lodge
ER Henry Rudewicz

2,001 or more members

1. Escondido, CA, Lodge
ER Melvin Hogan
2. Carmichael, CA, Lodge
ER Michael Koch
3. Vallejo, CA, Lodge
ER John Chamberlin

DIGEST OF ANNUAL REPORTS



This digest consists of excerpts and summaries of the Annual Reports of the Grand Exalted Ruler, the Elks National Service Commission, the Elks National Foundation, the Elks National Memorial and Publication Commission, the Board of Grand Trustees, and the Grand Secretary.

Homer Huhn, Jr.



Grand Exalted Ruler

Jo and I have been impressed in our travels over our nation with the warm friendship and hospitality that we encountered. No matter if we were attending a Lodge function or a State Association meeting, we were accorded honors far above our wildest expectations. This is evidence of the respect our members have for our Order and its Officers.

Elks and their families are basically people who like people. The depth of the affection and kindness afforded us has enriched our lives. The genuine warm quality of the Elks and their ladies whom we had the opportunity of visiting is our personal treasure chest. Some of them we may never see again, others we hope to see frequently. One thing is sure: all will be remembered by both of us.

With the help of a large percentage of our membership, especially those who won GER Awards, our efforts have been successful. Our contributions to the Elks National Foundation have exceeded the contributions of any other year—our Order has grown by 9,786 members and our lapsation has been reduced. We have been successful in all of our programs which will be revealed in the reports that will be given during our Convention.

My slogan "Individual Responsibility Assures Progress" has touched all of us. I believe the full understanding and the implementation of this slogan has resulted in progress that is not reflected in the statistics of our accomplishments. I would hope that this contagion of member responsibility continues throughout our Order in the years to come.

During my many years of service to our Order I have had the privilege of getting to know and working with our Past Grand Exalted Rulers. This association afforded me the opportunity to benefit from their experience just as the Exalted Rulers of the various Lodges should benefit from the experiences of their Past Exalted Rulers. The willingness with which these dedicated Elks give of their time and talents has served as an inspiration to me and all Elks. It has been necessary for me to call on them on many occasions and in every instance they have responded. My gratitude to them is boundless.

I have worked with and sat in many meetings of the Board of Grand Trustees and know of the great amount of work in which they are involved. The processing of building applications, the supervision of the investments of the Grand Lodge and of the Employees Pension Plan, the processing of applications to the Home as well as their duties in connection with its supervision and the approval of all expense claims submitted by those entitled to expenses are but a few of the duties this office entails.

Despite the multiplicity of their duties none of them have been neglected. The Grand Trustees have rendered great service to our Order and I wish to thank them for their promptness and efficiency in carrying out their various assignments.

The Grand Forum, the Supreme Court of our Order, renders invaluable assistance to our Order. These men are very learned in court and trial procedures as well as our Constitution and Statutes and take much time from their professions in order to guarantee that justice is served in those cases where due process of our laws has not been followed.

This year the Hon. Alex M. Harman, Jr., has capably served as Chief Justice. I extend to him and all members of the Grand Forum my sincere thanks for the service that they have rendered to our Order.

I have been privileged to have served our Order as Grand Secretary and am cognizant of the many duties that must be carried out by this important arm of our Order. The duties of this office are too numerous to set forth in this report and I wish to thank Grand Secretary Kocur for his cooperation and assistance.

He and his staff have been courteous and helpful, cheerfully responding to every request I have made of them.

My thanks to all of them, particularly to Mrs. Dorothy Morris, Paul D. Zimmer, Sol Solomon, Keith Barrett and Robert Sconce. Each of them are knowledgeable of and dedicated to their work and I will always be grateful to them for their friendship and assistance.

I can't speak too highly of the Management of our Home. Doral E. Irvin, the Executive Director of the Home, and his wife Kitty are to be commended for the long hours, dedication and devotion they have given to a somewhat perplexing and difficult assignment. They have earned the respect and affection of not only the residents at the Home but of the entire community.

As one who has served on many Grand Lodge Committees, I am fully aware of the tremendous amount of time and effort expended by our Grand Lodge Committees and I am grateful to those who served this year for the efficient and dedicated

service they have rendered in promoting our Grand Lodge Programs.

I wish to extend my sincere appreciation to Past Grand Exalted Ruler John L. Walker, Chairman of the National Foundation Trustees, and to those other Past Grand Exalted Rulers who serve as Trustees with him. I also wish to thank Nelson E. W. Stuart, the Executive Director, and his Office Staff for all the assistance they have provided in making this a record year. My sincere thanks to the many members who made it possible with their contributions.

The Elks Magazine is the official publication of our Order. Our General Manager, John R. Ryan, and his staff produce a Magazine of which we can all be proud. It is one of the finest fraternal publications in existence today.

I am grateful for the complete cooperation from Brother Ryan and his staff. Through this medium we have been able to contact our members and their ladies with our many messages and progress of the Order.

Chairman George I. Hall, Past Grand Exalted Ruler, and the members of the Elks National Convention Committee along with Convention Director Bryan McKeogh and his assistants Bud Hall and George Malekian are to be commended for their efforts on our behalf.

The choice of a Secretary to the Grand Exalted Ruler is most important. Such a person must be knowledgeable of the Order and be able to reflect the thinking of the Grand Exalted Ruler in all his correspondence. In addition he is responsible for the hundreds of matters of detail that arise throughout the year. The success of the Grand Exalted Ruler can be credited to him.

I was most fortunate in finding a man with these attributes in the person of James P. Ebersberger. He is a devoted Elk who has served Grand Lodge as District Deputy Grand Exalted Ruler, Grand Esteemed Lecturing Knight and has served on many Grand Lodge Committees. He is a Past President of the Pennsylvania Elks State Association and serves as Administrator of the Major Project of that Association. I cannot thank him adequately for the capable and efficient manner in which he has carried on the affairs of my office.

I am equally grateful to Mrs. Kathy Paul for her services. Her knowledge and secretarial experience has guaranteed a successful office operation. Her pleasant personality and dedication to her duties has made my office a pleasant place to work.

I also wish to thank Charles Cute, Secretary of Latrobe, Pennsylvania, Lodge No. 907 for the assistance he provided.

Recommendations

1. Our Order has again enjoyed a gain in membership but, as in past years, has reduced our gain to the smallest in the last few years. I, therefore, recommend that stronger efforts be exerted in this area in order that our growth would be commensurate with our total membership. I also urge greater emphasis on new applicants for membership.

2. I urge that our Officers Training Program be expanded and that consideration be given to a special program for Leading Knights in order that they be better prepared to serve as Exalted Ruler.

3. Mail received at my office and reports from the District Deputies indicate that many Lodges are flagrantly violating Section 172 of our Grand Lodge Statutes regarding Life and Honorary Life Memberships. Such practice has reduced the dues income of many Lodges to a dangerous level. I therefore recommend that our Statutes

DIGEST OF ANNUAL REPORTS

(Continued)

be amended in a manner to positively prohibit such violations.

4. I recommend that the image of our Order be improved. This can be done by all Lodges instituting a fix-up, clean-up program and becoming more involved in community programs. I urge that the Indoctrination Slides and Cassette be made available to other organizations such as churches and civic clubs in order that the good work of our Order become public knowledge.

5. I also recommend that our Indoctrination Program be updated with less emphasis on social activities and more emphasis be placed on our various Major Projects and Lodge and Grand Lodge Programs.

6. We have now, after many years, found that we must become politically involved in questions concerning our Order and stand united for the life of our great Brotherhood and recommend that more effort be extended in combating any legislation that would endanger our existence.

7. I recommend, as have many of my predecessors, that our Statutes be codified. This becomes increasingly important as our Officers Training Program expands. Conflicting Sections, Opinions and Decisions have raised many questions by those participating in this worthwhile program.

William J.
Jernick
Chairman



Elks National Service Commission

Our long standing and often repeated pledge never to forget hospitalized veterans has been faithfully kept by our dedicated hospital committees who welcome this necessary assistance from the lodges.

While we are proud of this record we know that what has been accomplished is not nearly so important as to what we do in the future. The development of a sound relationship between hospital committees, lodges, District Deputies and State Associations is vital to continued progress. Too often in the past the responsibility of our "Mission of Mercy" to hospitalized veterans has been delegated to our hospital committees. Only with a spirit of cooperation by the lodges can the needs of the veteran patients be adequately met. In these days of ever-mounting costs the regular grants from this commission to hospital committees are to be considered solely as "seed" money or "pump priming" funds for bare essentials. The intent is to provide a continuity of limited program planning and prevent interruption of our service. The need for "extras" for special occasions, holiday observances, and other programs always exists. They can be met only through help from all lodges. It is grati-

fying to report that this necessary help for the hospital committees is rapidly being recognized through an ever-growing concern by lodges, districts and State Associations. It must be understood that the distance of a veterans hospital from a lodge is not a valid excuse for non-participation in the project. A veteran from a lodge's home community seeking treatment would have to apply to that distant hospital.

An objective for participation by all lodges is attainable. The realization of its accomplishment is in the willingness of the lodge leadership to assume some portion of the debt we owe to the now sick and disabled defenders of our flag.

The Grand Lodge long ago gave the Elks National Service Commission the responsibility for making sure that the Order's resources could be mobilized promptly and effectively to meet whatever need might arise. The Commission's responsibility and authority also extends to national emergencies, whether natural disaster or enemy attack.

To make sure that Elkdom would have the financial muscle to do whatever job might arise and without a moment's delay, the Grand Lodge, every year since 1950, has voted a special appropriation that would be available immediately to start the wheels going in case of such an emergency. Backing this up is standby authority for the levy of a tax of \$1.00 per member which, today, would put more than a million and a half dollars at the disposal of the Elks National Service Commission to help the nation cope with any emergency.

Through a more efficient approach to our leather program, we were able to reduce the cost of our leather program from \$19,894 last year to \$8,949 this year, a cost reduction of over 50 percent. Approximately the same number of leather orders were processed as in the previous year; however, orders were restricted to less expensive types of leather. Since this leather is used only for the therapeutic programs, the less expensive leather served the same purpose and as well, according to hospital therapists who were contacted by this Committee.

Although Elk Hospital programs were expanded nationally to a record number of activities, the actual amount of money distributed by this Commission was reduced from \$280,504 last year to \$269,810 this year. This was accomplished as a result of reviewing current hospital program and streamlining program procedures in the field. In addition, a national program has been instituted to encourage lodge National Service Chairmen to run a small fund-raising affair (Veterans Remembrance Night) each year, thereby establishing a new tradition in Elkdom. This so-called "Operation Self-Help" is encouraging the lodge brothers to get involved and to do more for our hospitalized veterans. In this way, activities are not limited by the amount of funds received from Grand Lodge.

We are proud and gratified to report that lodges and State Associations throughout the Order are responding magnificently to appeals to assist financially. Many have inaugurated a lodge Veterans Remembrance fund-raising social each year in November with proceeds to be turned over to their nearest Veterans Hospital Committee or their State Associations Treasury for distribution where needed. They assure us that this will be an annual event not alone to assist financially, however small, but furthermore it will afford their members an

opportunity to participate personally in the fulfillment of the Elks solemn pledge never to forget the now sick and disabled defenders of our flag.

Our warm congratulations and grateful appreciation are extended to our hospital committees, State Associations and all lodges throughout the country for our continuing programs. Careful planning and excellent management of funds on their part, together with local supplemental fund-raising are largely responsible for the fine showing of the past year. Unfortunately, the cash value of their countless volunteer hours cannot be reflected in the details of our finances. However, it can be stated that, without this priceless asset, the herein results of professional auditing would have little meaning.

The possibility of an emergency in connection with our national defense or a major disaster always exists. To provide for such an eventuality, the delegates at our National Convention each year approve the adoption of a Resolution authorizing the Board of Grand Trustees to levy such an assessment not exceeding \$1.00 per year per member. Should such monies be needed, they would be expended under the direction of your Elks National Service Commission.

It is for this reason the members of this Commission consider it a distinct honor to be privileged to engage in the fulfillment of the Order's pledge never to forget our hospitalized veterans.

Our attempts to keep this solemn promise would be meaningless without the concern and deeds of that faithful group of dedicated Elks and their ladies whose willing hands and hearts have performed continual works of mercy in Veterans Administration hospitals throughout the nation.

"We Will Not Forget" is their slogan. For the meritorious work they are performing and for the resultant enhancement of the image of Elkdom, this Commission expresses its profound gratitude.

John L. Walker
Chairman



Elks National Foundation

Increased contributions, a conservative investment program, and sales of securities have resulted in another record year financially for the Elks National Foundation. The Foundation's annual report for the fiscal year April 1, 1977, through March 31, 1978 reveals contributions totaling \$2,895,493.25 bringing the 50-year cumulative figure to \$32,386,454.00 in donations. Sales during the year brought the cumulative gain on sales of securities to \$2,386,465.00.

During the 1977-1978 fiscal year the Foundation experienced its largest year of contributions in the history of the Foundation, an indication that the individual member is becoming apprised of the importance of the benevolent agency which has been created in our Order.

The following report of disbursements,

made possible through the gifts of members and philanthropic-minded individuals outside our Order, contains no item of expense for administrative purposes. The Foundation emphasizes again that as the Order's principal benevolent trust, it makes no deduction from income to defray administrative costs which amounted to \$338,517.72 and were paid by Grand Lodge.

Disbursements from Foundation income in 1977-1978 totaled \$1,433,765.51 and were distributed in the following manner:

State Association Projects \$327,250.00. Foundation Funds annually assist State Associations with established major projects and those being organized.

Scholarships Allocated to States—\$320,454.15. Scholarship awards to students nominated by State Association Scholarship committee judges.

"Most Valuable Student" Awards—\$393,579.05. This program provided scholarship awards, ranging from \$700.00 to \$3000.00, to outstanding students selected by State and National judges.

Emergency Educational Fund—\$310,482.31. This fund makes scholarship assistance available to the children of any Elk in good standing who lost his life or has become totally incapacitated.

"Hoop Shoot" Free Throw Competition—\$80,000.00. The Foundation made this sum available to the Grand Lodge for its youth program recognizing boys and girls in younger age brackets.

T. L. Bear Fund (Grants for Vocational Training) \$1,000.00.

Nathan O. Noah Scholarship Trust Fund—\$1,000.00.

The Annual report states that no part of the principal fund is distributed for any purposes; it is income earned through wise investment that perpetuates our charitable programs.

We invite our members to read the statistics of the Foundation's annual report, particularly those holding office and charged with leadership, and decide for themselves whether they and the areas under their Elks guidance are supporting the Elks National Foundation as generously as they should.



Dr. Leonard J. Bristol
Chairman

Board of Grand Trustees

Following the Close of the Grand Lodge Session and Installation of Officers in New Orleans, Louisiana, July 14, 1977, the Board of Grand Trustees met, organized and elected Leonard J. Bristol, Chairman; H. Foster Sears, Vice-Chairman; Frank Garland, Approving Member; A. Lewis Heisey, Secretary; Robert Grafton, Home Member; Edward M. Schlieter, Pension Member; Larry McBee, Building Application Member-East; and Marvin M. Lewis, Building Application Member-West.

The Board held meetings during the year as follows: October, 1977, Elks National Home, Bedford, Virginia; February,

1978, San Diego, California; May, 1978, Elks National Home, Bedford, Virginia; and beginning July 13, 1978, at the Town and Country Hotel, San Diego, California. The last meeting will adjourn at the conclusion of this Grand Lodge Session.

By direction of the Grand Lodge in session in New Orleans, Louisiana, the Board procured and presented suitable testimonials to retiring Grand Exalted Ruler George B. Klein and William H. Collisson, retiring Secretary of the Board of Grand Trustees.

The Board reviewed the limits of the Fidelity Bond covering all Officers, Officials and Employees of the Grand Lodge and considered these amounts to be adequate.

The Board reviewed the coverage and limits of insurance on the buildings and other property of the Elks National Home and its operations and they have been adjusted to conform with the best judgement of the Board.

The New England Merchants National Bank of Boston, Massachusetts, continues to act as investment counselors for the investments of the Grand Lodge.

During this past year, the Board of Grand Trustees has changed the handling of the Pension Trust, as per approval received at the Convention last July at New Orleans, Louisiana. These changes included: 1) Leaving Pension Trust with the Continental Illinois National Bank and Trust Company, with the bank acting as custodian and paying agent for the monthly pension payments; and 2) Appointing an Independent Investment Advisory firm to handle the investments and controlling the funds. The annual return from the monies in the Pension Trust has been increased from 4.123 percent to be better than 5.5 percent, and yet sound and prudent investment practices are engaged.

During the year, we received approval on the Elks Retirement Plan and had the plan printed. This has been delivered to every employee under the Elks Retirement Plan and a copy will be provided to each new employee. Copies of this new Retirement Plan have also been distributed to each of the Past Grand Exalted Rulers and members of the Board of Grand Trustees. Also, copies were furnished to the IRS and Department of Labor for their information and file.

The Pension Member of the Board of Grand Trustees continues to work very closely with the Actuary Agent and Legal Counsel to insure full compliance with the Pension Reform Act of 1974, and such changes as they occur. The Actuary Agent computes the contribution requirements each year and this is deposited on an annual basis. The employees make no contribution to this Pension Fund. In accordance with Section 37a., of the Grand Lodge Statutes, the Plan is administered by the Board of Grand Trustees, through their Pension Member. Periodic reports are made to the Board of Grand Trustees by the Pension Member and the Financial Advisory Service monitoring the funds.

From May 1, 1977, to May 1, 1978, the Board received and reviewed 281 applications from Subordinate Lodges requesting approval to purchase, sell, erect new buildings, make alterations or additions to existing buildings, purchase new furnishings, and to place mortgages upon their property. Authorization was granted by the Board and concurred in by the Grand Exalted Ruler for all of said applications in an amount totalling \$55,547,744.77 of which \$26,807,524.77 was for capital expenditures.



Wade H. Kepner
Chairman

National Memorial and Publication Commission

In describing the Elks National Memorial it is difficult to avoid superlatives. The majesty of its architectural design, the beauty of its interior, its masterpieces of art, have led artists, poets, critics and laymen alike to acclaim its perfection and to accord it high place among the notable memorials of the world.

During the past year more than 33,000 people visited the Building. Since its erection total visitors number over 3,000,000. Expenses covering maintenance of the Building are paid from the earnings of *The Elks Magazine*.

The Fidelity Appraisal Company of Milwaukee, Wisconsin, in its report of April 29, 1977, has appraised the Memorial and Magazine Buildings at a replacement cost of \$14,683,000 and a sound value of \$10,230,000.

Appropriate insurance coverage is maintained at all times by the Commission.

The Elks Magazine

On May 31, 1978, there was concluded the 56th year of the publication of *The Elks Magazine*. During the year ended on that date there were printed 19,967,157 copies of the Magazine. Total pages in the 12 issues for the period being reported, including covers, amounted to 708, an average of 59 pages per copy.

The Elks Magazine was conceived and instituted to be entertaining, as well as instructive. Primarily its purpose is to place in the hands of each one of the more than 1,634,000 Elks comprising the Order a monthly volume of fraternal information that will insure recognition of the Order's beneficent power; a keen appreciation of its uplifting mission; a deeper pride of membership and a constant inspiration to the renewal of fraternal obligations and an incentive to greater fraternal activity.

Established for three purposes: to publish news of the Order's activities on local, state and Grand Lodge level; to provide articles and features, both interesting and informative, for its readers so as to encourage their interest; and to maintain the best production standards in the interest of its advertisers by providing them with a suitable medium in which to display their messages to full advantage, thereby obtaining revenue over and above subscription income, to defray costs and produce a surplus.

During the past year the Magazine has continued to strive for the highest standards in its articles and feature material. The editor, in reviewing approximately 3500 manuscripts per year, seeks material of most appeal to Elks and their families.

Emphasis in articles the past year continued to be on such areas of wide reader appeal as business, human interest, medicine, technology, sports, and current events. In the area of current events, for

DIGEST OF ANNUAL REPORTS

(Continued)

example, the Magazine carried an article entitled, "Social Security: A Dream Renewed?" giving an in depth look at the new bill within weeks of its passage. Articles geared to the businessman included "OSHA: Will It Survive?" and "The Woe-ful World of the Workaholic." A look at "The ABC's of Diabetes" drew favorable response from across the nation.



Stanley Kocur

Grand Secretary

During the year ended March 31, 1978, our Subordinate Lodges added to their membership rolls 112,572 by initiation, 22,452 by dimit and 12,613 by reinstatement.

In the same period, 81,361 were dropped from the rolls for non-payment of dues, 199 expelled, 32,529 granted dimits and 23,762 lost by death. The total membership of the Order as of March 31, 1978 is 1,634,488, showing a net increase of 9,786. The total number of Lodges on March 31, 1978 is 2,228.

The Order continues to grow. This year we initiated 112,572 and added by dimit 22,452 and 12,613 by reinstatement. In the same period we lost 137,851 through deaths, dimits, expulsions and drops for non-payment of dues. We have instituted 16 new Lodges since the publication of the last Annual Report. These new lodges and the improvement in our lapsation efforts have made a substantial contribution to the gain achieved this year.

Our gain in membership represents a normal, healthy growth comparable to that attained in the last few years. We are still plagued with the perennial problem of Lapsation. This problem demands the attention of the Exalted Rulers, Secretaries and Committeemen for it is only in the Subordinate Lodge that it can be solved. I urge the Exalted Rulers, Secretaries and Committeemen to analyze the membership tables contained in this report and endeavor in the coming year to improve upon this year's membership record, not only by

adding to their rolls but by devoting an intensive effort to saving the delinquents.

The net assets of the Subordinate Lodges have reached the total of \$645,324,036, an increase of more than \$44,579,477 over last year. The reports indicate that while some Lodges are experiencing financial difficulties many others are enjoying a healthy financial condition due to the establishing of good business practices.

The Lodges are annually increasing their contributions in Charitable, Welfare and Patriotic Work. This year \$15,198,029.00 was expended in these worthwhile endeavors.

Our record to date is truly impressive and we can and do aspire to greater things in the years ahead. As membership is the basic ingredient in the success of any of our endeavors, we must continue to introduce Elkdom into new communities in the form of new Lodges. We must, by increasing patriotic endeavors and community service, maintain and enhance the public image of all our Lodges, thus attracting new members and strengthening pride in membership which is so important a factor in keeping members off the delinquent rolls. Membership in its various phases—Procurement, Indoctrination and Lapsation should be of paramount concern to all.

New Lodges

GRANTED DISPENSATION NAME AND NUMBER OF LODGE INSTITUTED
 Granted by Grand Exalted Ruler George B. Klein

4-29-77	Peninsula, WA, No. 2560	
6- 8-77	Summit County, CO, No. 2561	
6-21-77	North Houston, TX, No. 2562	

Granted by Grand Exalted Ruler Homer Huhn, Jr.

8- 7-77	Peninsula, WA, No. 2560	
9-25-77	Summit County, CO, No. 2561	
7-24-77	North Houston, TX, No. 2562	
10-16-77	Somers Point, NJ, No. 2563	
11-20-77	Gaithersburg, MD, No. 2564	
1-22-78	Forestville, MD, No. 2565	
2- 5-78	Plentywood, MT, No. 2566	
12-17-77	Lapeer Area, MI, No. 2567	
1-22-78	New Paltz, NY, No. 2568	
2-25-78	Payette Lakes, ID, No. 2569	
1-21-78	Rancho Cucamonga, CA, No. 2570	
1- 7-78	Jaser, AL, No. 2571	
3-25-78	Orleans-Eastham, MA, No. 2572	
4- 9-78	Corinth, MS, No. 2573	
4-30-78	Saugerties, NY, No. 2574	
4-29-78	Algona, IA, No. 2575	

Charters Revoked and/or Surrendered

1-24-78	Chester, PA, No. 488
4- 1-78	*Buckhead (Atlanta), GA, No. 1635
	*Merged with Atlanta, GA, No. 78

Benevolent Activities

Below is a list of Charitable, Educational, Welfare and Patriotic activities in which Subordinate Lodges are engaged, together with the total monies expended for the same during the Lodge year from April 1, 1977 to March 31, 1978:

ACTIVITIES	AMOUNT
Relief of Members, Widows, Orphans, Dependents, Burials, etc.	\$ 851,648
Summer Outings, Camps and Health Resorts	676,361
Cerebral Palsy	1,965,288
Crippled Children	1,829,544
Medical Aid and Hospitals	893,616
Care of Needy Families, including Thanksgiving and Christmas Baskets	1,367,026
Elks National Foundation	1,235,489
Youth Work (except for scholarships, free textbooks, etc.)	2,535,201
Scholarships, Free Textbooks, etc.	978,830
Red Cross, Salvation Army, etc.	335,230
Veterans' Relief	637,156
Miscellaneous	1,389,840
Flag Day, Constitution Day, Fourth of July, etc.	502,800
Total	\$15,198,029

Membership Gains And Losses By States

Lodge Year Ended March 31, 1978

State	Lodge Year Ended March 31, 1978	Gain	Loss
Alabama	182		
Alaska	232		
Arizona	713		
Arkansas	395		
California	211		
Canal Zone		24	
Colorado	1,191		
Connecticut		151	
Florida	2,008		
Georgia		740	
Guam		13	
Hawaii	19		
Idaho	734		
Illinois		614	
Indiana		7	
Iowa		367	
Kansas		849	
Kentucky	78		
Louisiana		252	
Maine	641		
Maryland, Delaware and District of Columbia	544		
Massachusetts	744		
Michigan	1,032		
Minnesota		748	
Mississippi	12		
Missouri	889		
Montana	596		
Nebraska		200	
Nevada	111		
New Hampshire		112	
New Jersey	299		
New Mexico	362		
New York	429		
North Carolina		126	
North Dakota		414	
Ohio	385		
Oklahoma	937		
Oregon	2,122		
Pennsylvania		324	
Philippine Islands	4		
Puerto Rico		8	
Rhode Island		173	
South Carolina		145	
South Dakota	78		
Tennessee	76		
Texas		16	
Utah	404		
Vermont	194		
Virginia		327	
Washington	40		
West Virginia		320	
Wisconsin		10	
Wyoming	64		
TOTALS	15,726	5,940	
NET GAIN	9,786		

Activities By States

The following table shows the amount expended in Charitable and Welfare work by each State and Special Jurisdiction during the period from April 1, 1977 to March 31, 1978:

State	Amount	State	Amount
Alabama	\$ 137,023	Nebraska	156,103
Alaska	171,767	Nevada	79,241
Arizona	307,068	New Hampshire	97,025
Arkansas	61,063	New Jersey	1,162,569
California	2,192,801	New Mexico	213,849
Canal Zone	22,395	New York	956,706
Colorado	588,152	North Carolina	212,073
Connecticut	256,027	North Dakota	205,523
Florida	744,038	Ohio	366,924
Georgia	108,927	Oklahoma	222,512
Guam	4,305	Oregon	579,571
Hawaii	60,492	Pennsylvania	676,320
Idaho	190,030	Philippine Is.	12,600
Illinois	415,362	Puerto Rico	7,240
Indiana	295,311	Rhode Island	111,130
Iowa	121,118	South Carolina	95,990
Kansas	108,686	South Dakota	126,637
Kentucky	61,057	Tennessee	134,167
Louisiana	64,402	Texas	368,242
Maine	122,803	Utah	147,610
MD/DE/DC	273,569	Vermont	135,614
Massachusetts	873,980	Virginia	116,800
Michigan	449,145	Washington	539,818
Minnesota	138,848	West Virginia	87,340
Mississippi	32,227	Wisconsin	195,450
Missouri	198,067	Wyoming	62,750
Montana	128,562	Total	\$15,198,029

The foregoing Digest of Annual Reports was prepared by the staff of *The Elks Magazine* from texts of the official reports involved. Each of the reports was published separately in its entirety. In addition, the Grand Exalted Ruler, the Grand Secretary, and the several Chairmen presented supplementary remarks at Grand Lodge Session held in San Diego, California, July 16-20. These remarks appear in the printed Proceedings of the Grand Lodge Session.

NEWS OF THE LODGES

(Continued from page 19)

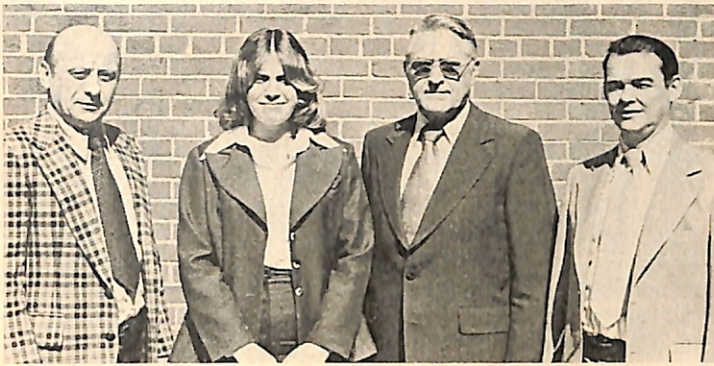

DURING a special meeting at Osbourne High School in Manassas, VA, the local lodge awarded a certificate of recognition and a \$50 savings bond to Donna Manchee for her academic achievement. Brother and Principal Victor Igidi (left) congratulated Miss Manchee, who thanked the Manassas Brothers, including ER Dick Horton and Est. Loyal Kt. Tom Dearden (right).

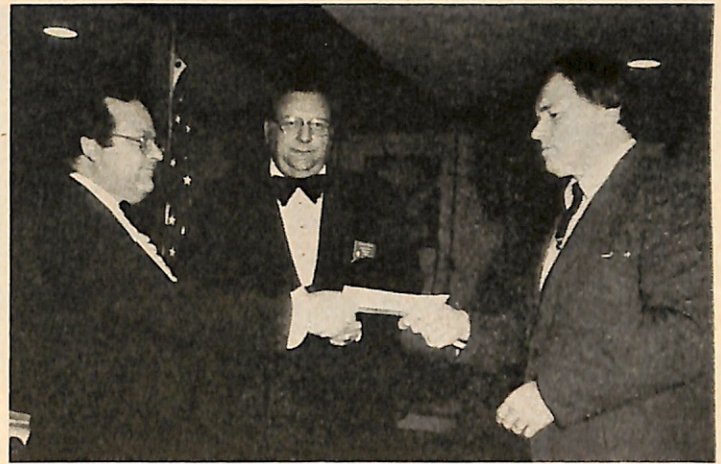

THE BROTHERS of Enfield, CT, Lodge were proud of immediate PER Charles Kenrick (center) and Brother Henry Lacroix (right) for their contributions to the National Foundation. Chm. Ronald Campbell (left) presented the pins and certificates to the PER for his sixth \$100 pledge and to Brother Lacroix for his first. PER Kenrick is working towards reaching the \$1,000 goal of honorary membership in the Foundation.



ORPHANED by a recent tragedy, the ten Brown children of Hillside, NJ, received aid from the local lodge. Then-ER Franklin Mann (third from left) and Charles Ritz (fourth) presented a check to Miss Gladys Brown (fifth), while (from left) Mrs. Barbara Smith, Mrs. Barbara Kelly, Mrs. Louise Ballard, Irving Brown, and Mrs. Phyllis Scanga observed.



THE ELKS' ladies of Lyndhurst, NJ, Lodge demonstrated their continuing support of the Brothers' programs recently. Past Pres. Betty Werenski (right) presented a \$5,000 check to Est. Lead. Kt. Louis Giunta to be utilized as the lodge requires.



THE BROTHERS of Mt. Pleasant, PA, Lodge paid tribute to two of their fellow members recently. For their work in the community and dedication to Elkdom, Chester Echard (seated, left) and George Sebeck (seated, right) received certificates of commendation from (standing, from left) PER Robert Kalp, then-ER Joseph Wooleyhan, Trustee Willard Stevens, and Jess Stairs, state representative.



THE YMCA of Wakefield, MA, received a donation from the local lodge recently. Ken MacArthur (second from right), director of the YMCA, thanked the Brothers for the check, which was presented by (from left) Est. Loyal Kt. James Callanan, Pete Santoro, youth activities co-chairman, and Co-chm. Vin Sampson.



THE ANNUAL Exalted Ruler's Ball, during which Brothers Homer Schuler (second from right) and Vaughn Whisker (third) were honored, was held at Bedford, PA, Lodge. Immediate PER Philip Metzel (right) and ER Dale Weyant presented certificates of appreciation and commended the two gentlemen for their dedication to the community and to Elksdom.



THE BUILDING fund of Titusville, FL, Lodge was augmented recently with Brother Ted O'Keefe's (second from left) contribution of \$1,000. (From left) PDD Kenneth Morton, ER Douglass Durrett, and immediate PER George Storrer, who began the fund, thanked Brother O'Keefe for the donation.



A REQUEST for aid was made to Fair Lawn, NJ, Lodge by the Fair Lawn Mental Health Center for mentally disturbed children. Mrs. Davidson of the Center thanked PER and Chm. Vincent Schindel, PERs Nibby Ruberto, Thomas DeHauski, and Edward Sparrow, and then-ER Walter Rubenacker for three checks which allowed the Center to buy needed equipment.

A PROCLAMATION declaring Elks Youth Week was signed by Governor James Edwards (seated) of South Carolina. Dignitaries on hand to witness the event included (standing, from left) SP A. Herman Schwacke Jr., Chm. Allen Gotbeter, Secy. and Treas. David Craig, and ER W. Howard Walker of Charleston Lodge.



A DISPLAY of historical flags was created and erected by Glen Cove, NY, Lodge for exhibition at various business locations throughout the area. Brothers (from left) Anthony Ferrioli, immediate PER Anthony Petrella, Est. Lect. Kt. Frank Cassano, Albert Greifer, Americanism chairman, and Treas. John Gentile were welcomed by Manager William Hall to the dedication of the display at a local bank.

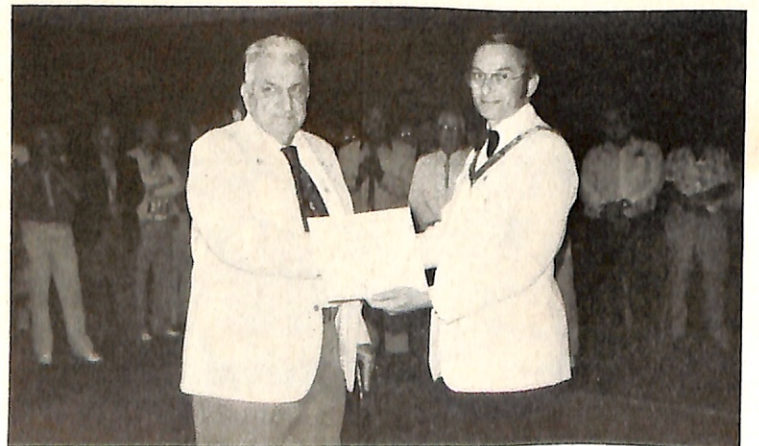

FOR HIS contribution of \$2,000 to the National Foundation, Brother Francis Ryan (left) received a permanent benefactor's certificate. Then-ER Jerold Mills of Pompano Beach, FL, Lodge presented the award and congratulated Brother Ryan for earning a first in their lodge's history.



A SPECIAL plaque of appreciation was presented by Leo Henebury (third from left), president of Somerville, MA, Lodge's Youth Bowling League, to ER Joseph Bruno (fourth) recently. Also attending the awards night were James Colbert, activities chairman, Sal Caruso, Al Webster, bowling chairman, and Marty Corbin.

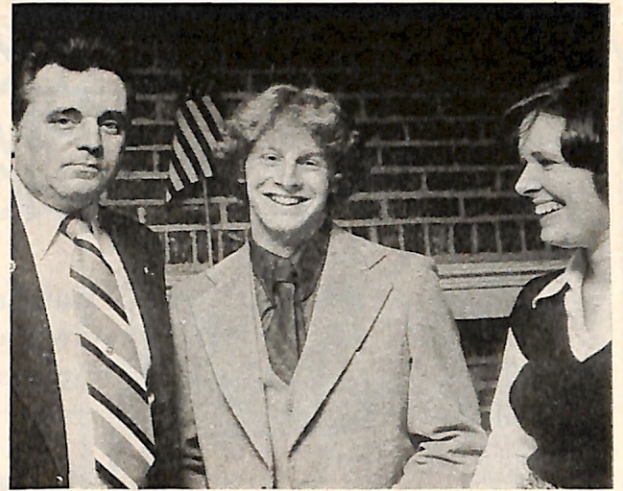

A DINNER honoring youths, during which Warren Tucker (center) received special recognition as Teenager of the Year, was held by New London, CT, Lodge. ER Robert Bliven Sr. (left) and Dr. Margaret Sheridan, member of the judges committee, were on hand to congratulate the young man.



FIRST PRIZE was received by Lexington, MA, Lodge for its float displayed in the local Patriots' Day parade. Children dressed to represent the various areas of the Brothers' community involvement rode on the colorful float. Present at the parade were (from left) ER Henry Marsh, Richard Samaria, youth chairman, Elks' lady Elizabeth Brennan, immediate PER Gordon Osgood, Est. Lect. Kt. Joseph Brennan, and Est. Loyal Kt. Dave Olson.

THE ANNUAL golf tournament sponsored by Point Pleasant, NJ, Elks was held recently at Bey Lea Golf Course. Open to all Elks and their guests, the competition was followed by a dinner and awards ceremony held at the lodge. Among those who participated in the event were (back row, from left) ER Donald Koch, Herm Bowers, Chm. Donald McIntyre, Frank Wolfesberger (front row, left), and Fred Birdsall.



THE BASEBALL players of the Southside Jacksonville, FL, Lodge team were given jackets by Brother Henry Kelly (front row, center). Brother Kelly, who personally paid for the gifts as a tribute to the boys' athletic endeavors, was thanked by the team and its coach Richard Maloney (back row, right).



LITTLE league ball player champions were honored at a luncheon held at Cambridge, MA, Lodge recently. Immediate PER Charles Sullivan, PER James McElhenny, and ER Michael Kapopoulos were on hand to cheer the boys and to present them with league jackets.

FREE-Burpee Fall Bulb and Gift Ideas Catalog

— with dozens of
Christmas and holi-
day gift ideas for
gardeners.

Burpee's 1978 Fall Bulb and Gift Ideas Catalog has 64 big colorful pages of finest quality bulbs that produce large beautiful blooms — grapes — berries — fruit trees — flowering shrubs — trees — house plants — harvest and garden aids.



Send for your free Burpee Catalog today and get your entry form for Burpee's Second Garden Party Drawing. Grand Prize: Trip for 2 to the famous gardens of Holland and England — the kind of vacation that most gardeners dream about, and very few ever experience. Hundreds of other prizes. (No purchase necessary to win.)

For your free Burpee Catalog mail coupon below today. Burpee's Garden Party Drawing ends Dec. 31, 1978. Void where prohibited by law.
© Burpee Seed Co. 1978

BURPEE SEED CO.

7788 Burpee Building, Warminster, PA 18974
Clinton, IA 52732, Riverside, CA 92502
(Please mail to nearest address.)

Please send a free copy of Burpee's 1978 Fall Bulb and Gift Ideas Catalog — including an entry form for Burpee's Garden Party Drawing to:

Name _____ (Please print)
Address _____
City _____ State _____ Zip _____

WHY BUILD ANYTHING LESS THAN THE BEST!

Compare before you build.

Don't waste your time or money building just any ordinary clock. Now you can easily and inexpensively build some of the world's best grandfather clocks. Beautifully designed and exquisitely detailed. Each is a simple do-it-yourself pre-cut kit that saves you up to 50% over a finished clock.

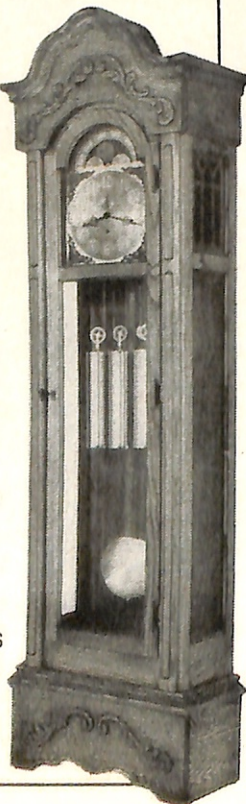

Send Now for your FREE brochure featuring the finest grandfather, wall and mantel clock kits.

WESTWOOD

CLOCKS 'N KITS

Uncompromised in quality
3210 Airport Way
Dept. 8-05-Z
Long Beach, CA 90806
(213) 595-4981

ELKS FAMILY SHOPPER

Useful and unique
new products for
home and office

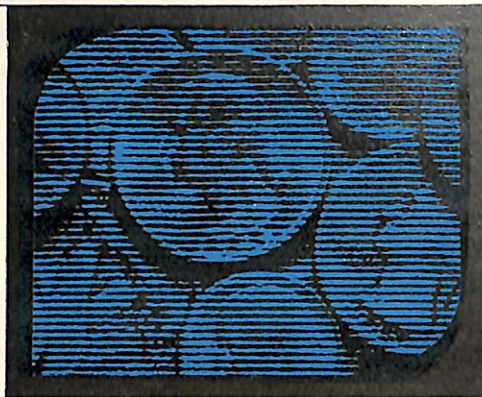

THE FUNCTION OF A SMALL CAR SERVED BY THE TRIPED. Two-passenger, three-wheeled convertible, with a length of 74 inches, 32 inches wide, weighs 140 pounds. Legally a moped, gets almost 100 miles per gallon of regular gasoline. Produced by the Pivar Motor Co. of Farmingdale, Long Island, N.Y. Sold thru moped dealers for around \$750.

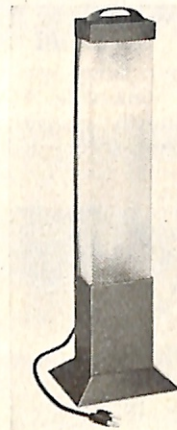

PORTABLE LIGHTING FIXTURE INCREASES PLANT GROWTH. The "Beacon" has a low pressure sodium lamp with a life of 18,000 hours. Produces a soft yellow light not attractive to insects. Constructed of heavy gauge steel with baked on paint finish and an easy grip handle. Also perfect for backyard and patio light at night. For dealer-packet write: Consumer Lighting Products, P.O. Box 7079, St. Louis, MO 63177.

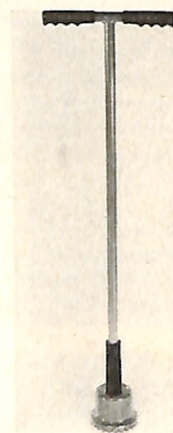

END TROUBLE OF CUTTING GRASS around automatic sprinkler heads with convenient Handy Sprinkler Head Trimmer. No bending. 42" long. One downward twist of trimmer cuts grass and keeps it out of sprinkler's way. Made of steel with vinyl grips, push-spring action, fits most pop-up type sprinkler heads. Fully guaranteed. \$14.95 ppd. Spear Engineering Co., Dept. 2005, Box 7025 Colorado Springs, CO 80933.

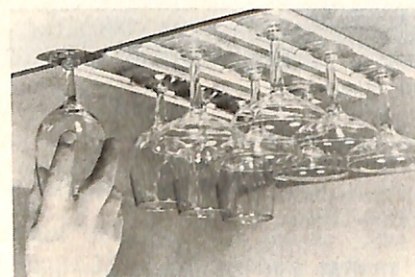

HANG GLASSES OR MUGS IN UNUTILIZED SPACES. Glass Trax™ are 10" plastic strips with runners to hold any stem glass or mug upside down. Wood grain finish. One pair will hold 3 to 5 glasses. 1 pair \$1.25 ppd. 5 pairs \$1.15 per pair ppd. 10 or more pairs, \$1.00 per pair ppd. + 50¢ per order for postage and handling. Money back guarantee. The Idea Center, Dept. E8, 373 Parrott Drive, San Mateo, CA 94402.

SUN AUTO SUN SHADES



"Take the sizzle out of the sun!"
DOES NOT OBSTRUCT VIEW
RIDE UP TO 15° COOLER with SIDLES SHADES
Custom made from durable aluminum to block out the sun's rays. Easily installed and instantly removable. Increases air conditioner efficiency and saves passengers and contents from the ravages of a blazing sun. For free information send year, make, series, model (sedan, station wagon, pickup, bus, etc.), and style (2 or 4 door), with your name and address to SIDLES MFG. CO., INC., Box 3537E, Temple, TX 76501. For questions and/or same day shipment on Master Charge/VISA/UPS COD phone orders, call TOLL FREE (800) 433-3101. In Texas call (817) 778-1636.

Fast, Efficient, Reliable

COMPOST BINS

Turn garden and kitchen wastes into rich, fertile compost to improve poor soil and feed your plants. Grow bountiful harvests of vegetables and more beautiful flowers. Scientifically designed bins produce valuable compost in weeks. No turning the heap. Make a ton in one season. Send for FREE catalog:

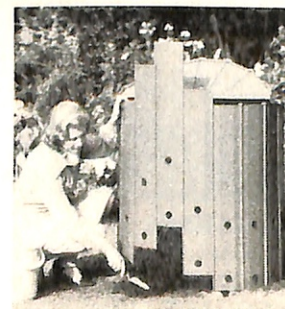

ROTOCROP

143 Aero Park PATENT 3951294
Doylestown, PA 18901

PROTECTION AND BEAUTY OFFERED BY UNIVERSAL ADJUST-A-GATE.

Easy to install and available in 4 designs. This gate can hinge right or left, and swing in or out. Has slide bolt for pad lock or cylinder lock. Security Iron Co., c/o Wm. Winterfeld, 1201 South Broad, New Orleans, LA 70125. Dealer inquiries invited.



"PROTEKTOR" PERSONAL SECURITY AND SAFETY ALARM. Portable, Personal, Versatile. Self-contained, can be held in a hand. Battery Powered. Triggered by slightest movement to emit piercing alarm. For use on all types of doors, medicine cabinets, vehicles, suitcases, handbags, etc. Suburban Electronics, Dept. E. 1250 West Dorothy Lane, Dayton, Ohio 45409.

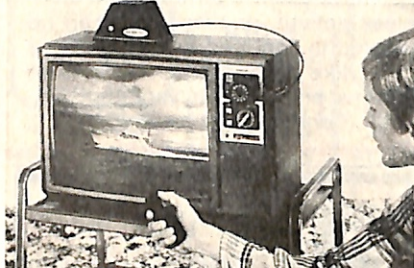

CHANGE TV CHANNELS FROM YOUR EASY CHAIR. Empress Remote Control TV Channel Changer fits all standard TV sets (color and black and white) made after 1965. Requires only minutes to install, no tools needed. 1 yr. limited guarantee. \$39.95 ppd. Empress, 753 St. Francis St., Mobile, AL 36601.

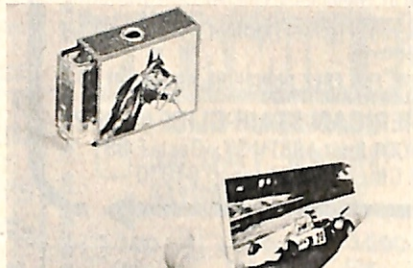

LOOKS LIKE AN ART-ILLUSTRATED FRENCH MATCHBOOK, but with one squeeze like magic a flame appears from its side. Works on an entirely new principle. Unique lighter easily refilled with butane and made to last. Adds a European air to anyone's demeanor. \$6.95 + 50¢ postage & handling. John J. Scully & Associates, P.O. Box 4268, Burbank, CA 91503.



CHILDREN BETWEEN AGES 5 to 10 aided by "TOOTH FAIRY HOUSES" to develop good oral hygiene habits. Hand-decorated 3 1/2" square plastic boxes. Toothbrush House has removable toothpaste/toothbrush container. Treasure House has chest for baby teeth. Blue or Pink \$5.95 ea.—2/\$10.95 ppd. Ca residents add 6% sales tax. Pinky-Dee, P.O. Box 5024, Dept. E, Covina, CA 91723.

EASIER TO WASH DOWN DRIVEWAYS, sidewalks, patios, poolside, tennis courts with new tool that attaches to garden hose. 9 high-velocity brass jets deliver 4 ft. spray of water to move dirt, leaves, debris. Molded from industrial plastic and non-mar rubber wheels. \$49.95 ppd. 1 yr. guarantee. Power Sweep, Dept. EK, 32351 Del Obispo, San Juan Capistrano, CA 91675. (30 day Free Trial)



Gorgeous 18K Gold On Silver Turquoise Ring



ONLY \$12

Now, for the first time goldsmiths and silversmiths combined their talents to create this spectacular ring of 18K gold electroplated on a sterling silver base with mosaic inlays of turquoise—all at an unbelievably low introductory price of \$12 each, 2 for \$19.90. Please add \$1.50 for postage, insurance and handling per order. Designed to sell for \$30, each ring is handsomely gift boxed and hand finished so expertly that it carries a full 5 year quality guarantee for normal use. 7 day money back guarantee. Ring sizes now available are 4-12 (see ring size rule).

NEW FRONTIER Collectors Club
5600 McLeod N.E.,
Albuquerque, N.M. 87192
© 1978, New Frontier

NEW FRONTIER Collectors Club, Dept. E88
5600 McLeod N.E., P.O. Box 13567,
Albuquerque, N.M. 87192

Rush me the following ring (s)
Size _____ Size _____ One @ \$12.00 plus \$1.50 postage, handling, insurance Two @ \$19.90 plus \$1.50 postage, handling, insurance. Payment Enclosed _____

Your Signature _____

Master Charge
 VISA/BankAmericard

Exp. Date _____ Account No. _____

Bank No. Master Charge Only _____

Print Name _____

Address _____

City _____ State _____ Zip _____

CUT OUT TO FIND YOUR RING SIZE

- 4
- 5
- 6
- 7
- 8
- 9
- 10
- 11
- 12

PERSONALIZED ELKS MUGS

Beautifully handcrafted porcelain mugs that will show your first name, lodge number and the Elks Emblem.



\$14.95

CA residents add 6% Sales Tax
Send check or money order to

LARGO BISQUE PORCELAINS
1802 ANDREWS
TUSTIN, CALIFORNIA 92680



TONGA BANANA STAMP & 110 OTHERS-ONLY 10c!

A genuine postage stamp from tropical Tonga—shaped like a real banana! Ten large France pictorials picturing awesome Neolithic stone monuments, a towering cathedral, the Riviera seacoast and more. Plus, giant collection of 100 different stamps from around the globe. Also, other exciting stamps to examine Free. Buy any or none, return balance, cancel service anytime, but this mammoth collection of 111 stamps is yours to keep for just 10c! **HARRIS, Dept. IF-77, Boston, MA 02117**



LAST U. S. SILVER COIN SETS

Never again will silver be used in coin mintage! Most has already been remelted so these UNCIRCULATED coin sets will increase in value yearly! 1964-\$6.50; 1963-\$7.00; 1962-\$7.50; 1961-\$8.00; 1960-\$8.50. All 5 sets \$35.00 (mounted in lifetime holders). M/C, Am. Exp., & BOA (VISA) accepted. Add \$2.00 for ins. & hdng. Centre Coin Co., Box 1, Dept. K-8, Sherman Oaks, Calif. 91413.

CAVALIER PANT BOOT

Handsomely crafted in genuine glove leather. Smooth, no-seam vamp; adj. buckle strap. Resilient ribbed sole and 1" heel. **BROWN, BLACK, WHITE, NAVY, WINE, CAMEL, BONE.** Comb. sizes: 6-10 1/2 N, 5-10 1/2 M & W



KRAUS Originals
-like wearing gloves on your feet"

\$23

plus \$1.75 P & H

OLD PUEBLO TRADERS

Dept. E8V

600 S. Country Club, Tucson, AZ 85716

Send \$1 for our latest Fashion Catalogue (refundable with first purchase)



Remove painful Corns, Callouses, Warts easily and safely.

Just rub on medicated Corn Stick. Amazing scientific formula immediately goes to work to reduce pain and remove the corn, wart or callous. No messy liquids, salves or risky cutting and scraping. One application is often enough. **\$1.59**

Corn Stick P. O. Box 25073 • Tamarac, FL 33320



1000
RETURN
ADDRESS
LABELS **\$1.00**

1000 gummed economy name and address labels printed in black with ANY name, address, zip code. Up to 4 lines.

Order S717 Set of 1000 Economy Labels (boxed) . . \$1.00

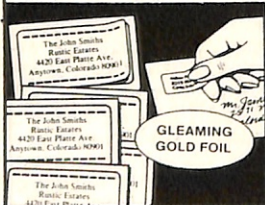

250
Self-Stick
GOLD FOIL
LABELS **\$1.98**

Gleaming gold foil labels stick to any clean, dry surface — need no moistening. Rich black printing, classic border.

Order P6128 Set of 250 Gold Foil Labels (boxed) . \$1.98



250
Self-Stick
WHITE GLOSS
LABELS **\$1.98**

Glossy white self-stick labels cling to any smooth surface — no moistening. Sharp black printing up to 4 lines.

Order P6030 Set of 250 White Gloss Labels (boxed) \$1.98

Walter Drake 3298 Drake Bldg.
Colorado Springs, CO 80940

NAME _____
ADDRESS _____
CITY & STATE _____ ZIP _____

_____ S717 1000 Labels @ \$1 each \$ _____
_____ P6128 Gold Foil Labels @ \$1.98 each \$ _____
_____ P6030 White Gloss Labels @ \$1.98 ea \$ _____
Add 20¢ per set for postage & handling \$ _____
SATISFACTION GUARANTEED Total \$ _____

"SAVE YOUR HEART"

with a **STAIR-GLIDE®** Stairway Elevator

RENTAL-PURCHASE Program Available

Your STAIR-GLIDE® installs easily and in less than 2 hours. No marring walls or stairway. No special wiring required. Shipped directly from factory within 4 days. STAIR-GLIDE®...the nation's largest selling stairway elevator! UL LISTED.

USED BY THOUSANDS: CARDIAC PATIENTS, ARTHRITIS, SENIOR CITIZENS, PHYSICALLY RESTRICTED, POST OPERATIVES...and household convenience.

WRITE FOR FREE BROCHURE AND NAME OF DEALER NEAREST YOU.

AMERICAN STAIR-GLIDE® CORP.
4001 East 138TH ST., Dept. E-88
Grandview, Missouri 64030

Carry TEN TIMES a Wheelbarrow Load with INCREDIBLE EASE!

These BIG, strong carts are perfectly balanced on two huge wheels — roll easily over lawns and gardens — carry up to 400 lbs. of load — huge volume capacity means you make fewer trips — you'll save time and steps.

If you are still struggling with a wheelbarrow or inadequate cart (with tiny wheels) send for FREE Cart Catalog. Build-it-yourself kits, too.

GARDEN WAY RESEARCH, Dept. 80128
Charlotte, Vermont 05445

REAL FOREIGN MONEY only 10¢

Japanese WWII note from the Philippines, 1951 Bulgarian leva with hidden watermark, 1930 Chinese bill for 10 customs gold units, 2 other notes from Chile & Korea all 10¢! Also, other exciting notes to examine. Buy any or none, return balance, cancel service anytime. Harris Bank Notes, BF-46, Boston, Mass. 02117

Elks Family Shopper

consumer/news

If you want the satisfaction of growing your own vegetables, but you don't have a lot of space, grow them in containers. All you need is enough sun and space for a good sized container.

Most vegetables grow well this way, according to the U.S. Department of Agriculture. And to give you tips on how to go about it, USDA has a free booklet called *Growing Vegetables in Containers*. For your copy just send a postcard to the Consumer Information Center, Dept. 669F, Pueblo, Colorado 81009.

Look for varieties of vegetables that have been hybridized for container growth, or those that can be adapted to confined quarters. Some crops, like corn, produce large root systems and need a very big con-

(Continued on page 40)

Yours Free!

With your first by-mail purchase from **Watkins** catalog of world-famous spices, extracts and home remedies

Send now for your Free Catalog

FREE BONUS if you act now: \$1.29 bottle of double-strength Vanilla with your first by-mail purchase from our new catalog that abounds with hundreds of delicious & delightful items made in the Watkins tradition! **SPECIAL OFFER EXPIRES 9/19/78**

Clip coupon now and mail with your name & address to:
Watkins Dept. KEBG
Winona, Minn. 55987

Serving you from the comfort of your home since 1868

THE CONTINENTAL

FACTORY SPECIAL
\$299.95
Compare at \$499.95
And Save \$\$\$

7 H.P.

New 1978 models
One full year warranty.

RIDING MOWER

MANUFACTURER TO YOU

Over 3,000 Big, Powerful 7 H.P. Briggs & Stratton Mark VII Riders, featuring a bigger cut. Fully assembled in crates, delivered free. Dozier blade & grass catcher available. We are not a Mfg. Sales Co. selling other Co's. products, we are the manufacturer. Order now or send for free brochure while they last! Write . . .

CONTINENTAL MFG. DEPT. E
3205 E. Abrams St., Arlington, Tx 76010
Phone: 817-640-1198

Compare our prices on HIGH POTENCY VITAMINS



AND SUPPLEMENTS FROM
NUTRITION HEADQUARTERS
All prices POSTPAID! Satisfaction guaranteed or money back.

"KITCHEN FARM" SEED SPROUTER
Make your own bean sprouts. Complete Kit..... **1.00**

PROTEIN DIET POWDER
16 oz. CONTAINS 416 GRAMS OF PROTEIN
lb. **3.98**

ORGANIC IRON Supreme
100 TABLETS **1.49**
500 for 4.95

DOLOMITE & BONE MEAL
100 TABLETS **69¢**
500 for 2.65

VITAMIN E Beauty Cream
1 oz. Jar **1.00**

SUNFLOWER SEED KERNELS
12 oz. **89¢**
6 Pkgs. for 4.99

"SPECIAL C-500"
500 mg. Vit. C Plus Rose Hips, 200 mg. Bioflavonoids, 50 mg. Rutin, 25 mg. Hesperidin
100 TABLETS **1.29**
500 for 6.15

500 MG. BRAN TABLETS
Easy way to get this important wheat fiber.
300 TABLETS **\$1**

Our "TOP-B" B-COMPLEX "50"
Famous Formula at a Sensational Low Price!
Every Capsule Contains 50 mg. B1, B2, B6, Niacinamide, Panto Acid, Choline, Inositol; 50 mcg. B12, Biotin; 50 mg. Paba; 100 mcg. Folic Acid.
50 Capsules **2.49** 100 Capsules **3.98**
250 for 9.49

500 MG. ASCORBIC ACID VITAMIN C
100 TABLETS **95¢**
500 for 4.49

WHEAT GERM RAW FLAKES
1 lb. **59¢**
5 lbs. for 2.79

KELP Tablets (Iodine)
100 TABLETS **39¢**
1,000 for 2.49

Desiccated LIVER
100 TABLETS **79¢**
500 for 3.49

10 MG. ZINC TABLETS
100 TABLETS **49¢**
1,000 for 4.45

PAPAYA PAPAIN (Digestant)
100 TABLETS **75¢**
500 for 3.25

100 MG. VITAMIN B2 (RIBOFLAVIN)
100 TABLETS **1.25**
500 for 5.50

HERBAL DIURETIC
100 TABLETS **1.75**
500 for 6.50

GIANT 20 MINIM. WHEAT GERM OIL CAPSULES
40 CAPSULES **1.10**
120 for 2.89

83 MG. POTASSIUM TABLETS
100 TABLETS **1.25**
500 for 5.00

50 MG. VITAMIN B6
100 TABLETS **95¢**
500 for 4.25

HERBAL LAXATIVE
100 TABLETS **95¢**
500 for 4.35

ONE GRAM DIET PROTEIN TABLETS
Each contains 1 gram of protein.
240 TABLETS **4.95**
No carbohydrates
No fats

BIG 4 KELP, VIT. B6, LECITHIN, CIDER VINEGAR
100 TABLETS **98¢**
500 for 3.88

BREWERS YEAST TABLETS
250 TABLETS **65¢**
1,000 for 1.95

19 GRAIN LECITHIN CAPSULES (1,200 mg.)
100 CAPSULES **1.59**
300 for 4.39

RAISIN NUT & SEED Trail Mix Natural Snack
12 oz. **1.49**

LECITHIN POWDER Dissolves Easily
8 oz. BOTTLE **1.49**

100 MG. GINSENG TABLET
50 TABLETS **99¢**
250 for 3.95

250 MG. SUPER GINSENG TABLET
100 TABLETS **2.98**
500 for 12.95

FORMULA S-6 (Comparable to "STRESS TABS 600")
60 TABLETS **2.89**

ALFALFA Tablets
100 TABLETS **49¢**
500 for 1.95

100 MG. VITAMIN B12
100 TABLETS **1.19**
500 for 4.25

ONE GRAM (1000 mg) VITAMIN C
With Rose Hips
100 TABLETS **1.49**
500 for 7.29

DOLOMITE Calcium Rich
100 TABLETS **49¢**
500 for 1.85

100 MG. VITAMIN B2 (RIBOFLAVIN)
100 TABLETS **1.25**
500 for 5.50

HERBAL DIURETIC
100 TABLETS **1.75**
500 for 6.50

GIANT 20 MINIM. WHEAT GERM OIL CAPSULES
40 CAPSULES **1.10**
120 for 2.89

83 MG. POTASSIUM TABLETS
100 TABLETS **1.25**
500 for 5.00

50 MG. VITAMIN B6
100 TABLETS **95¢**
500 for 4.25

HERBAL LAXATIVE
100 TABLETS **95¢**
500 for 4.35

ONE GRAM DIET PROTEIN TABLETS
Each contains 1 gram of protein.
240 TABLETS **4.95**
No carbohydrates
No fats

BIG 4 KELP, VIT. B6, LECITHIN, CIDER VINEGAR
100 TABLETS **98¢**
500 for 3.88

BREWERS YEAST TABLETS
250 TABLETS **65¢**
1,000 for 1.95

19 GRAIN LECITHIN CAPSULES (1,200 mg.)
100 CAPSULES **1.59**
300 for 4.39

RAISIN NUT & SEED Trail Mix Natural Snack
12 oz. **1.49**

LECITHIN POWDER Dissolves Easily
8 oz. BOTTLE **1.49**

100 MG. GINSENG TABLET
50 TABLETS **99¢**
250 for 3.95

250 MG. SUPER GINSENG TABLET
100 TABLETS **2.98**
500 for 12.95

FORMULA S-6 (Comparable to "STRESS TABS 600")
60 TABLETS **2.89**

ALFALFA Tablets
100 TABLETS **49¢**
500 for 1.95

100 MG. VITAMIN B12
100 TABLETS **1.19**
500 for 4.25

ONE GRAM (1000 mg) VITAMIN C
With Rose Hips
100 TABLETS **1.49**
500 for 7.29

DOLOMITE Calcium Rich
100 TABLETS **49¢**
500 for 1.85

100 MG. VITAMIN B2 (RIBOFLAVIN)
100 TABLETS **1.25**
500 for 5.50

HERBAL DIURETIC
100 TABLETS **1.75**
500 for 6.50

GIANT 20 MINIM. WHEAT GERM OIL CAPSULES
40 CAPSULES **1.10**
120 for 2.89

83 MG. POTASSIUM TABLETS
100 TABLETS **1.25**
500 for 5.00

50 MG. VITAMIN B6
100 TABLETS **95¢**
500 for 4.25

HERBAL LAXATIVE
100 TABLETS **95¢**
500 for 4.35

ONE GRAM DIET PROTEIN TABLETS
Each contains 1 gram of protein.
240 TABLETS **4.95**
No carbohydrates
No fats

BIG 4 KELP, VIT. B6, LECITHIN, CIDER VINEGAR
100 TABLETS **98¢**
500 for 3.88

BREWERS YEAST TABLETS
250 TABLETS **65¢**
1,000 for 1.95

19 GRAIN LECITHIN CAPSULES (1,200 mg.)
100 CAPSULES **1.59**
300 for 4.39

RAISIN NUT & SEED Trail Mix Natural Snack
12 oz. **1.49**

LECITHIN POWDER Dissolves Easily
8 oz. BOTTLE **1.49**

100 MG. GINSENG TABLET
50 TABLETS **99¢**
250 for 3.95

250 MG. SUPER GINSENG TABLET
100 TABLETS **2.98**
500 for 12.95

FORMULA S-6 (Comparable to "STRESS TABS 600")
60 TABLETS **2.89**

ALFALFA Tablets
100 TABLETS **49¢**
500 for 1.95

100 MG. VITAMIN B12
100 TABLETS **1.19**
500 for 4.25

ONE GRAM (1000 mg) VITAMIN C
With Rose Hips
100 TABLETS **1.49**
500 for 7.29

DOLOMITE Calcium Rich
100 TABLETS **49¢**
500 for 1.85

100 MG. VITAMIN B2 (RIBOFLAVIN)
100 TABLETS **1.25**
500 for 5.50

HERBAL DIURETIC
100 TABLETS **1.75**
500 for 6.50

GIANT 20 MINIM. WHEAT GERM OIL CAPSULES
40 CAPSULES **1.10**
120 for 2.89

83 MG. POTASSIUM TABLETS
100 TABLETS **1.25**
500 for 5.00

50 MG. VITAMIN B6
100 TABLETS **95¢**
500 for 4.25

HERBAL LAXATIVE
100 TABLETS **95¢**
500 for 4.35

ONE GRAM DIET PROTEIN TABLETS
Each contains 1 gram of protein.
240 TABLETS **4.95**
No carbohydrates
No fats

BIG 4 KELP, VIT. B6, LECITHIN, CIDER VINEGAR
100 TABLETS **98¢**
500 for 3.88

BREWERS YEAST TABLETS
250 TABLETS **65¢**
1,000 for 1.95

19 GRAIN LECITHIN CAPSULES (1,200 mg.)
100 CAPSULES **1.59**
300 for 4.39

RAISIN NUT & SEED Trail Mix Natural Snack
12 oz. **1.49**

LECITHIN POWDER Dissolves Easily
8 oz. BOTTLE **1.49**

100 MG. GINSENG TABLET
50 TABLETS **99¢**
250 for 3.95

250 MG. SUPER GINSENG TABLET
100 TABLETS **2.98**
500 for 12.95

FORMULA S-6 (Comparable to "STRESS TABS 600")
60 TABLETS **2.89**

ALFALFA Tablets
100 TABLETS **49¢**
500 for 1.95

100 MG. VITAMIN B12
100 TABLETS **1.19**
500 for 4.25

ONE GRAM (1000 mg) VITAMIN C
With Rose Hips
100 TABLETS **1.49**
500 for 7.29

DOLOMITE Calcium Rich
100 TABLETS **49¢**
500 for 1.85

100 MG. VITAMIN B2 (RIBOFLAVIN)
100 TABLETS **1.25**
500 for 5.50

HERBAL DIURETIC
100 TABLETS **1.75**
500 for 6.50

GIANT 20 MINIM. WHEAT GERM OIL CAPSULES
40 CAPSULES **1.10**
120 for 2.89

83 MG. POTASSIUM TABLETS
100 TABLETS **1.25**
500 for 5.00

50 MG. VITAMIN B6
100 TABLETS **95¢**
500 for 4.25

HERBAL LAXATIVE
100 TABLETS **95¢**
500 for 4.35

ONE GRAM DIET PROTEIN TABLETS
Each contains 1 gram of protein.
240 TABLETS **4.95**
No carbohydrates
No fats

BIG 4 KELP, VIT. B6, LECITHIN, CIDER VINEGAR
100 TABLETS **98¢**
500 for 3.88

BREWERS YEAST TABLETS
250 TABLETS **65¢**
1,000 for 1.95

19 GRAIN LECITHIN CAPSULES (1,200 mg.)
100 CAPSULES **1.59**
300 for 4.39

RAISIN NUT & SEED Trail Mix Natural Snack
12 oz. **1.49**

LECITHIN POWDER Dissolves Easily
8 oz. BOTTLE **1.49**

100 MG. GINSENG TABLET
50 TABLETS **99¢**
250 for 3.95

250 MG. SUPER GINSENG TABLET
100 TABLETS **2.98**
500 for 12.95

FORMULA S-6 (Comparable to "STRESS TABS 600")
60 TABLETS **2.89**

ALFALFA Tablets
100 TABLETS **49¢**
500 for 1.95

100 MG. VITAMIN B12
100 TABLETS **1.19**
500 for 4.25

ONE GRAM (1000 mg) VITAMIN C
With Rose Hips
100 TABLETS **1.49**
500 for 7.29

DOLOMITE Calcium Rich
100 TABLETS **49¢**
500 for 1.85

100 MG. VITAMIN B2 (RIBOFLAVIN)
100 TABLETS **1.25**
500 for 5.50

HERBAL DIURETIC
100 TABLETS **1.75**
500 for 6.50

GIANT 20 MINIM. WHEAT GERM OIL CAPSULES
40 CAPSULES **1.10**
120 for 2.89

83 MG. POTASSIUM TABLETS
100 TABLETS **1.25**
500 for 5.00

50 MG. VITAMIN B6
100 TABLETS **95¢**
500 for 4.25

HERBAL LAXATIVE
100 TABLETS **95¢**
500 for 4.35

ONE GRAM DIET PROTEIN TABLETS
Each contains 1 gram of protein.
240 TABLETS **4.95**
No carbohydrates
No fats

BIG 4 KELP, VIT. B6, LECITHIN, CIDER VINEGAR
100 TABLETS **98¢**
500 for 3.88

BREWERS YEAST TABLETS
250 TABLETS **65¢**
1,000 for 1.95

19 GRAIN LECITHIN CAPSULES (1,200 mg.)
100 CAPSULES **1.59**
300 for 4.39

RAISIN NUT & SEED Trail Mix Natural Snack
12 oz. **1.49**

LECITHIN POWDER Dissolves Easily
8 oz. BOTTLE **1.49**

100 MG. GINSENG TABLET
50 TABLETS **99¢**
250 for 3.95

250 MG. SUPER GINSENG TABLET
100 TABLETS **2.98**
500 for 12.95

BY MAIL POSTPAID

VITAMINE

400 UNIT CAPSULES
 50 DAY SUPPLY **88¢**

100 FOR **\$1.49** 500 FOR **\$7.25** 1000 FOR **\$13.98**

Limit: One of Any Size to A Family

Mail Coupon with remittance to
NUTRITION HEADQUARTERS
104 West Jackson, N 1812
Carbondale, Ill. 62901

© 1977 Nutrition Hdq.

Money Saving MAIL ORDER BLANK **RUSH Your Order Now to:** THE BEST TIME TO SAVE IS NOW!
NUTRITION HEADQUARTERS
104 West Jackson St.— N 1812
Carbondale, Ill. 62901

We Pay ALL Postage

List items you wish here:

QUAN-TITY	SIZE	NAME OF PRODUCT	TOTAL PRICE

SATISFACTION GUARANTEED WE PAY ALL POSTAGE TOTAL—amount enclosed

PRINT NAME _____
ADDRESS _____
CITY _____ STATE _____ ZIP _____

Sun Shield

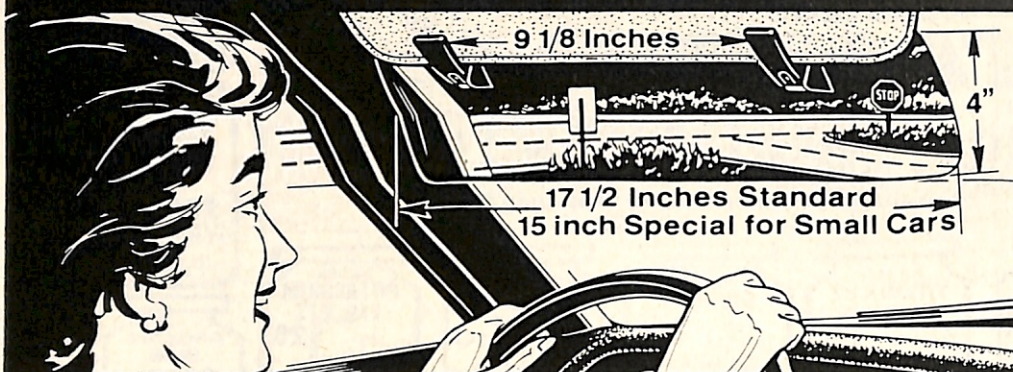

DOUBLES your driving COMFORT

- Reduces ALL GLARE and HEAT, front or side, Day or Night
- Accepted by leading safety authorities • Positive screw clamps hold securely
- Universally adjustable for look-through or shade-and-look-under.
- SATISFACTION GUARANTEED (Return within five days for full refund)

THE IDEAL GIFT • MOST ENJOYED • MOST APPRECIATED

Sun Shields, Inc. • 9179 General Court • Plymouth, MI 48170

Check or money order enclosed; Michigan residents ONLY add 4% tax.

- \$5.00 for one Sun Shield, shipped postpaid promptly.
- \$9.00 for 2 Sun Shields - Make your passenger comfortable, too!
- \$42.00 Doz. (minimum, one order) for group buyers - fleet owners.

E Specify 15 in. LENGTH (not car model) for sub compact & small foreign cars.

Name _____ Street _____

City _____ State _____ Zip _____

Elks Family Shopper

consumer/news

tainer. Other plants such as pole beans, cucumbers, and tomatoes will need to be supported.

Container vegetables are pretty agreeable and make few demands when it comes to location. Absolute requirements are 5 hours or more of full sun, enough space to set the containers, and adequate air circulation. It's convenient to have a water faucet for a hose nearby, but it's not essential.

Once you meet these demands, you can put the containers anywhere—on a patio or deck, terrace, balcony, window box, garage roof, walkway. If you don't have any available ground space, you can grow vegetables in hanging baskets.

Drainage can be a problem with this kind of gardening. With smaller containers, wherever possible use drip saucers to catch excess water. A large container without a saucer might be better off slightly elevated, rather than sitting directly on a solid surface like a cement or brick patio. If the container stays in contact with a solid surface, water can accumulate, causing root rot as well as patio stains. You can
(Continued on page 42)

The Earth Stove™

Beautiful Low Cost Wood Heat

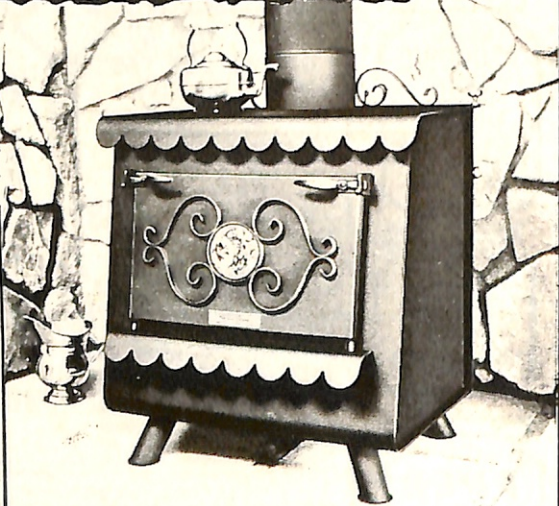
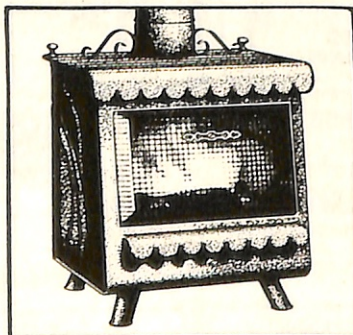

YOU CAN SAVE MONEY NOW!

The Earth Stove™ thermostatic fireplace stove has brought big savings in heating bills to thousands of comfort conscious households. Wood heat the Earth Stove way and save!

Check these Earth Stove features:

- Automatic Thermostat • Preheating Manifold • Removable Door For Open Fireplace • Large Cook Top Surface • Burns Up To 14 Hours On One Filling

YOU CAN CALL TOLL FREE NOW!

DIAL 1-800-547-6849

OR WRITE THE EARTH STOVE
10725 S. W. TUALATIN-SHERWOOD RD
TUALATIN, OR 97026

The Earth Stove, Inc.
1978

FOR YOUR FREE BROCHURE 24 HR. SERVICE

SAVE UP TO **\$171.60**

on a famous
TROY-BILT Tiller!

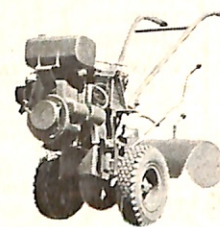

Just
ONE HAND!

"Off Season Savings" now in effect! Right now is the best time ever to learn about the amazing TROY-BILT Roto Tiller-Power Composter... the "breakthrough" machine that's allowing anyone—of any age—with any soil—to easily have a fabulously fertile, productive garden! For free complete details, prices, write today to:
TROY-BILT Tillers, Dept. 80558
102nd St. & 9th Ave., Troy, NY 12180.

PROSTATE

Amazing formula has helped thousands get rid of prostate pain and distress. End problems such as pain, dribbling, urgency, retention and getting up nights. Write today for...

FREE REPORT

Rush free report on prostate relief.

Name _____ Age _____

Address _____

City _____ St _____ Zip _____

**Proscio, Dept. EKS
Box 5644, Santa Monica, Calif. 90405**

SPECIAL OFFER:
THE COMPLETE
SET OF 4 PLATES
ONLY \$9.98

ONLY
\$3
PER PLATE



A. IMARI CART



B. IMARI PINE



C. IMARI RICKSHA



D. IMARI MUM

Genuine Porcelain 22-Karat Gold-Trimmed IMARI-STYLE COLLECTOR'S PLATES

Wonderful news for lovers of fine Oriental Porcelain! Collectors today are paying astronomical prices for genuine Imari ware, according to a feature article in a famous national newspaper. A famous San Francisco store specializing in Oriental Antiques stated that slightly chipped or cracked Imari pieces would sell today for \$125 to \$225 each. Perfect 17th Century pieces bring \$5,000 or more, but even 20th Century Imari is now being collected!

Our exclusive Imari-style plates come from Honshu rather than Kyushu, but you'd have to be an expert on Oriental porcelain to know that... they have the same kind of intricate "Nishikide" (brocade) patterns intermixed with "Pana" (floral) designs and landscapes. They display the same range of brilliant "Kakiemon" colors — from the distinctive "iron red" maroon and dark "cobalt" blue, to bluish-green turquoise, light blue and yellow. And each plate is lavishly trimmed with genuine 22K. gold, both on the rim and in the design itself!

Each of the four delicate, intricate designs is different, both in subject and in the rich colors used — so a single plate is a jewel to be admired — and the complete set of 4 a decorator's dream come true! Create a lavish, eye-catching wall or cabinet display, or actually use them as dessert or butter plates or candy dishes, to beautify your company table and win guests' compliments!

Hurry, order your set of these exquisite 6½" plates today — and if you're not totally delighted and thrilled with their beauty and workmanship — if a single admiring guest can even come close to guessing how little you paid — return them within 14 days and we'll cheerfully refund your money (except postage, handling and insurance). Mail coupon now!

© 1978 American Consumer, Inc., Caroline Rd., Phila., PA 19176

MAIL NO-RISK COUPON TODAY

AMERICAN TREASURY, Dept. IMR-15
 Caroline Road, Philadelphia, PA 19176

Please rush me the following Imari-style Genuine Porcelain Plates, trimmed in 22 Karat Gold, at \$3 each plus 50¢ for postage, handling & insurance.

- (#003) Design A (#029) Design C
- (#011) Design B (#037) Design D
- (#045) Complete Set(s) of 4 Plates only \$9.98 plus \$1.50 shipping per set

SAVE! For only \$18.98 plus \$2.50 shipping, order 2 sets and delight someone with a truly different gift that's sure to be prized. If after receiving my order I'm not delighted, I may return it within 14 days and you will refund the full purchase price except postage & handling).

Total amount enclosed \$_____ PA residents add 6% sales tax. Check or money order, no CODs please.

CHARGE IT: (check one) Exp. Date _____

- Visa / BankAmericard American Express
- Master Charge Bank Number _____

Credit Card # _____

Name _____

Address _____ Apt. # _____

City _____ State _____ Zip _____

Canadian customers please send orders to: Mail Store Ltd. Dept. IMR, 170 Brockport Drive, Rexdale, Ontario M9W 5C7 (Ontario & Quebec residents add sales tax)

8759
 Div. of American Consumer, Inc.

Wallester...
looks like a holster...
acts like a wallet!

the famous genuine leather **SHOULDER-HOLSTER WALLET...** the theft-preventer used by European business men for years!

What a clever way to protect your valuables! Ingenious design has enough room for money, passports, important papers, yet fits easily under your arm—with no unsightly bulge! Convenient shoulder strap is so comfortable, you'll hardly know you're wearing it. Rich Tan glove leather has flap closing, outside zipper pocket. A welcome "bon voyage" gift! (Z802223), **\$23.50**



pennsylvania station 340 Poplar Street, Hanover, Pa. 17331

---SATISFACTION GUARANTEED—MAIL TODAY!---



pennsylvania station, Dept. Z-8519 340 Poplar Street, Hanover, Pa. 17331

Pennsylvania Station's **SATISFACTION GUARANTEED** Policy

If you're not completely delighted with your purchase—at any time, for any reason—just return it to us for a full, fast refund.

Kindly send _____ SHOULDER-HOLSTER WALLET(S) (Z802223) for just **\$23.50** plus \$2.00 postage and handling on full money-back guarantee.

CHARGE IT TO ONE OF THE FOLLOWING ACCOUNTS:

American Express Carte Blanche Diners Club
 Visa/BankAmericard Master Charge Interbank # _____

Account # _____ Exp. Date _____

Enclosed is \$ _____ (check or money order) (PA res. add sales tax)

NAME _____ (please print or type)

ADDRESS _____

CITY _____ STATE _____ ZIP _____

Check here and send 50¢ for a year's subscription to our full-color catalog of fine gifts. (Z801209X)

© Pennsylvania Station, 1978

NOW! BADGE-A-MINIT™.M.
BREAKS THE PRICE BARRIER...
MAKE BUTTONS LIKE THESE FOR EVERY COMMUNITY USE

COMPLETE SYSTEM

\$19.95



While the cost of everything else is skyrocketing, **BADGE-A-MINIT, Ltd.** announces another breakthrough in badge-making technology. Now you can make the same high quality, colorful, plastic-protected, metal pin-back badges and buttons instantly for fairs, reunions, local events, school and club activities, elections, for business promotions or just for Fun for **LESS** than ever before! Discover "Badge Power": power to persuade, promote or create sympathy with your cause; let the guests at your next party "let it all hang out" with buttons that they make and wear upon arrival. Make one or one hundred — whenever the occasion calls for strong motivation. The button business can be a great side line for an enterprising son or daughter, too!

GET FREE SAMPLE BUTTON AND FULLY ILLUSTRATED DETAILS

The **BADGE-A-MINIT** system includes steel and fiberglass reinforced Lexan plastic hand die press, high impact color coded die set, 12 badge shells, 12 pin-back parts, 12 pastel perforated message discs, 12 plastic protective circular discs and colorful literature on all **BADGE-A-MINIT, Ltd.** accessories plus fully illustrated operating instructions.

BADGE-A-MINIT, Ltd., Dept. EL-88, Box 618, Civic Industrial Park, La Salle, Illinois 61301

Yes, send me a free sample button and fully illustrated details.

I'm convinced. Rush me the complete system. I've enclosed \$19.95 (check or money order) plus \$1.75 for postage and 5% sales tax for Illinois residents. Or use my credit card indicated below.

VISA (Bank Americard) Master Charge

Diners Club American Express Carte Blanche

Credit Card # _____ Exp Date _____

Inter Bank # _____

NAME _____

ADDRESS _____

CITY _____ STATE _____ ZIP _____

SIGNATURE _____

UNCONDITIONAL MONEY BACK GUARANTEE

Elks Family Shopper
consumer/news

use short pieces of wood, for example, to raise the pots up one or two inches.

A six inch diameter pot with a soil depth of 8 inches is the minimum size for vegetables. This size is good for lettuce, herbs, peppers, radishes, and other shallow-rooted vegetables. Root crops—such as beets, carrots, radishes, and turnips—need depth and enough surface space to fill out to their mature size.

You'll need to get very large containers for regular-size tomatoes, for squash, pole beans, cucumbers and corn. Half barrels, wooden tubs, or large, pressed-paper containers work well.

Have you been thinking about **going back to school**—but aren't sure how to go about it? Whether you want to take a few courses be-
(Continued on page 44)

NEW! Complete Home FRUIT GRINDER and CIDER PRESS

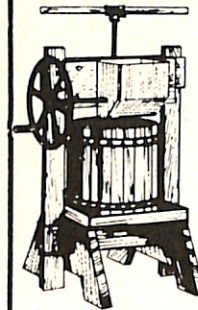

An extremely efficient double purpose unit available completely assembled or in low cost kit form. Grind your own apples (and many wine making fruits) in the top mounted grinder—then press the pulp to produce delicious cider and fruit juices. Enjoy fresh pure cider, and vinegar for year 'round cooking.

from bruised or fallen apples. Full bushel capacity—over 4 ft. tall! Constructed from spruce and Vermont maple hardwood to last a lifetime. Plans and kits also available. Send for free catalog.

GARDEN WAY RESEARCH
Dept. 80128P, Charlotte, Vermont 05445

Amazing Mini-Vac PUMP

Pumps Water Out or In by the TON

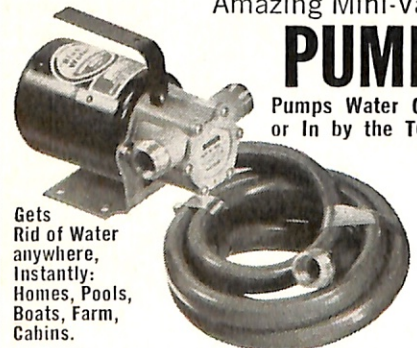

Gets Rid of Water anywhere, Instantly: Homes, Pools, Boats, Farm, Cabins.

Pumps up to 350 gallons (1½ tons) per hour . . . lifts water 20 feet . . . pushes water 50 feet high. Just plug into any electrical outlet and it's ready to use. It will drain or empty flooded basements, boats, pools, sumps, tanks, silo pits etc. Or in reverse it will water gardens, fill pools, fill a boat's water supply, etc. Everything complete in one kit. Built to commercial professional standards. Instant self-priming pump. Stainless steel wear plates, glass fiber reinforced case, rock rubber impeller. System includes air cooled motor, six-foot heavy-duty ground cord, two suction and discharge hoses, brass strainer, etc. Ten year replacement plan guarantee. **\$49.95** plus \$4.00 pp. and Hdg.

Send check or M.O. or Charge American Express or BankAmericard (Give Sect. No. and Exp. Date) 15 day Money Back guarantee

J. W. HOLST, INC. Dept. EK-88, 1864 E. US-23 East Tawas, Mich. 48730

At Last!

A Full-Feature Workbench at an Affordable Price!

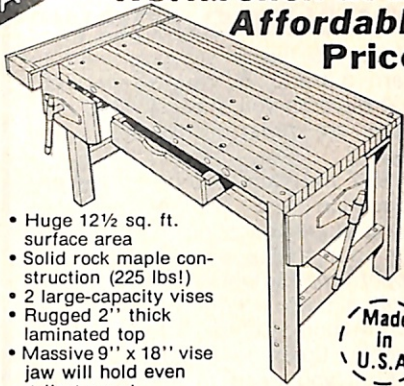

- Huge 12½ sq. ft. surface area
- Solid rock maple construction (225 lbs!)
- 2 large-capacity vises
- Rugged 2" thick laminated top
- Massive 9" x 18" vise jaw will hold even delicate work
- Adjustable leg levelers adjust workbench to uneven floor surfaces
- Easily disassembles for moving
- Available in kit form, too!
- Optional tool well & tool drawer also available



Until now, quality workbenches have usually been too expensive and too small. This huge, extremely versatile bench is available direct from the factory at an incredibly low price.

Garden Way Research, Dept. 80128W
Charlotte, Vermont 05445

TO: Garden Way Research, Dept. 80128W
Charlotte, VT 05445

Please send me your free information about the New Garden Way Home Workbench, including details on the build-it-yourself kits.

Name _____
Address _____
City _____
State _____ Zip _____



If you wear a size 14½ to 28½, 38 to 60

... look slimmer, younger, prettier!

send for this Roaman's **FREE CATALOG**

FREE! 104 page fashion catalog in full-color. Over 500 Fall and Winter fashions designed to flatter your figure.

- over 27 pages of sportswear
- over 23 pages of dresses and outfits
- over 8 pages of foundations
- over 10 pages of lingerie
- over 6 pages of extra-wide boots and shoes

... all value-priced to save you money

mail this coupon today!

Roaman's Dept. 1402
270 Market Street
Saddle Brook, N.J. 07662

Please rush me my **FREE CATALOG**.
please print to assure delivery

name _____
address _____ apt _____
city _____
state _____ zip _____

NEED HELP GETTING UP?

ARTHRITIS, HEART DISEASE, PARKINSONS, INJURY, or other Handicap Do these words have a special meaning to you? Do you have to occasionally struggle to get up from a chair? Should you be getting up more often? In the event of an Emergency could you get up? Become **INDEPENDENT** again with the help of **CUSHION-LIFT®** chairs and recliners from Ortho-Kinetics, the leader in Quality Engineered Products.

FREE HOME TRIAL

For information on our complete line of Cushion-Lift® products write or call Ortho-Kinetics today. We will send you a Free Brochure, information on Medicare coverage and arrange for your Free Home Trial, without obligation.



Ask about MEDICARE coverage



ORTHO-KINETICS, INC.

P.O. Box 2000-EC898
Waukesha, Wisconsin 53186
(414) 542-6060



**FOR IMMEDIATE RESPONSE
CALL TOLL FREE: 1-800-558-2151**

The International Silver Monogrammed Wine Goblet

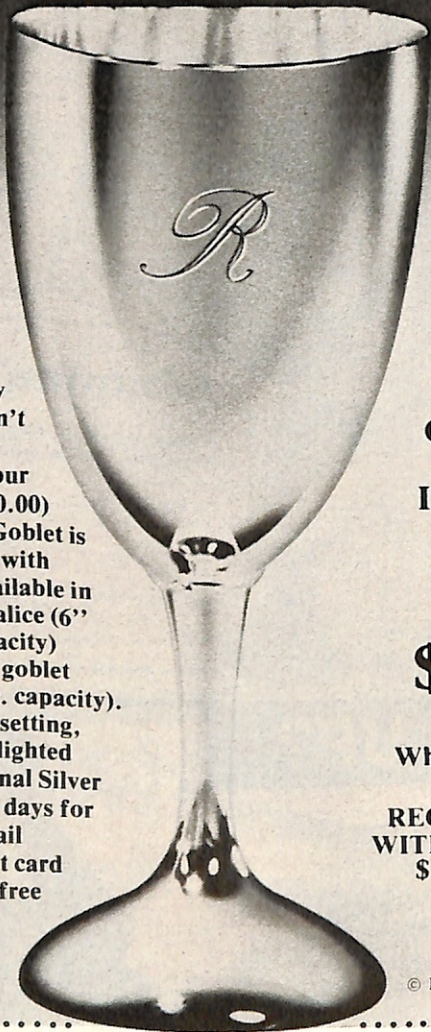

Start your collection of magnificent silver-plated stemware at these remarkable low prices. You really can't find a better value anywhere. A set of four goblets (normally \$50.00) is just \$35.95. Each Goblet is beautifully engraved with your own initial. Available in both elegant wine chalice (6" high with a 7 oz. capacity) and a majestic water goblet (7" high with a 10 oz. capacity). For the perfect table setting, order both. If not delighted with these International Silver Goblets, return in 30 days for a full refund. Just mail coupon below. Credit card holders may call toll free 800-243-3755 (in Connecticut, call 235-6383).

The
Great Silver
Goblet by
International
Silver

ONLY
\$8⁹⁹ Each
When You Order A
Set Of Four
REGULAR PRICE
WITH MONOGRAM
\$12.50 EACH

© INTERNATIONAL SILVER CO.

Crown-Castle, Ltd. Dept. WG-59

51 Bank Street, Stamford, Conn. 06901

Please send me the silverplated International Silver Goblets I have ordered below. If I am not absolutely delighted I may return within 30 days for full refund. (Please add 50c postage & handling for each goblet ordered)

Enclosed is \$ _____

Charge My: American Express Diners Club BankAmericard (Visa) Master Charge

Card No. _____ Exp. Date _____

Signature _____

Check Style & Quantity Desired	7 Oz. Wine Goblets	10 Oz. Water Goblets
<input type="checkbox"/> One—\$9.95 (@ \$12.50 value)		
<input type="checkbox"/> Two—\$18.95 (@ \$25.00 value)		
<input type="checkbox"/> Four—\$35.95 (@ \$50.00 value)		
<input type="checkbox"/> Eight—\$67.95 (@ \$100.00 value)		

MONOGRAM
THIS INITIAL

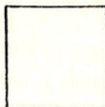

Print clearly. Leave blank if you wish your goblets without monogram.

NAME _____

ADDRESS _____

CITY _____ STATE _____ ZIP _____

..... Conn. Residents Add 7% Sales Tax

Elks Family Shopper

consumer/news

cause you like a subject, want to learn a trade, or maybe even get that diploma you started years ago, there are programs available for you.

And the Department of Health, Education and Welfare has put some suggestions down on paper. For your free copy of *Educational Opportunities for Older Adults*, just send a postcard to the Consumer Information Center, Dept. 689F, Pueblo, Colorado 81009.

First you need to sit down and figure out what it is you really want. Pick something because you like it, and you'll have a much better chance of being motivated to really get a lot out of the class.

Once you have a general idea of what it is you'd like to do, you can start looking for the courses to put your plans into action.

Places to look for the courses you want include:

- ⊙ Adult education programs sponsored by local public school systems.
- ⊙ Courses and special activities in vocational, technical, and high schools.
- ⊙ Courses in community colleges and universities for a modest fee or without charge.

If financing is a problem, you'll be glad to know that the federal government also sponsors several loan, scholarship, and work-study programs to help people enrolled in post-high school vocational, certificate, and degree programs. You can get information on these sources of assistance from the financial aid

(Continued on page 46)

**GOLFING!
FISHING!
BOATING!
TENNIS!**



**Show your pride in the Elks!
Wear a summer cap with the Elks emblem.**

Order now for summer! Buy one for you and your friends. Adjustable head sizes and fully washable. Your choice of cool comfortable nylon mesh combination or lightweight texturized knit.

Knit \$5.50 -:- Mesh \$5.00

Colors available: Lt. Blue, Yellow, Tan, Lm. Green, Red, Royal & Black, Lt. Blue, Maize, Red, Black, Green, Orange.

Send name, address & quantity desired with check or money order to:

BRONSON DISTRIBUTING

1556 E. 6600 S., Rt. 4 -:- Ogden, Utah 84403

Include 50¢ for shipping & handling.

Allow 4 - 6 weeks for delivery.

Money back guarantee.

Buy 12 or more & get your lodge number included.

L.L.Beantm

Outdoor Sporting Specialties

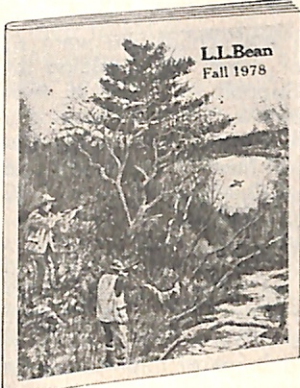

FREE
Fall
Catalog

136 fully illustrated pages featuring quality outdoor apparel and footwear for men and women. Winter sports equipment, hunting and camping gear. Many items of our own manufacture. All guaranteed to be 100% satisfactory or your money back. Our 66th year of providing dependable high-grade sporting specialties.

SEND FREE CATALOG

Name _____
Address _____
City _____
State _____ Zip _____

L. L. Bean, Inc.
7141 Cedar St., Freeport, ME 04033

DO-IT-YOURSELF

FINE GRANDFATHER
CLOCK KITS

STARTING UNDER

\$200

(including West German movement)

- Heirloom quality
- Solid 3/4" hardwoods: black walnut, cherry, mahogany, oak
- Easy to assemble, parts pre-cut
- Solid brass West German chiming movements
- Money back guarantee
- Factory direct prices
- Prompt shipment

MASTER CHARGE and BANKAMERICARD/VISA ACCEPTED

Write for FREE color catalog

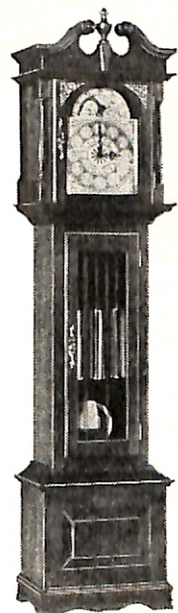

EMPEROR
CLOCK COMPANY
WORLD'S LARGEST MANUFACTURER
OF GRANDFATHER CLOCKS

Dept. 603, Emperor Industrial Park
Fairhope, Alabama 36532

Fishin' Fever Sale - Save \$300!

DAY-NIGHT MARKERS

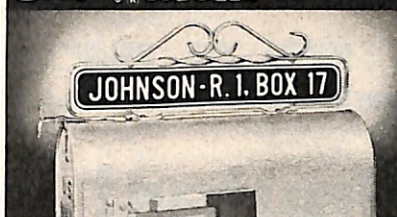

THE JOHNSONS 2917
Style M \$1095

2917
Mr & Mrs R A JOHNSON
Style NM \$1595

JOHNSON R I BOX 17
Style MF \$1295

JACK & DEE ARMSTRONG
R T I BOX 13
Style EOM \$2195

R A JOHNSON 2917
Style EM \$1495

Here's How The Sale Works:

Along about this time of year, everybody gets fishin' fever, so we're having a fishin' fever sale! Order before September 30th, deduct \$3.00 per marker. Or, go fishin' for awhile, and order before October 31st, deduct \$1.00 per marker. If you hurry, you'll save more, but either way you save money! America's #1 nameplates feature:

- Same wording both sides. Any wording you want, up to 17 letters & numbers on 18" long plate, 6 on short 7" plate.
- Raised white reflective letters on a tough black enamel coating—visible Day-n-Night!
- Satin-finish solid aluminum scrolls and frames.
- Completely rustproof, easy to install.

hot line

You can order anytime, 24 hours a day. Call us at (303) 471-9850.

THE SOONER YOU ORDER - THE MORE YOU SAVE!

We ship in 48 hours / Satisfaction guaranteed or your money back.

SINCE 1949
Specialty ENGINEERING COMPANY -
Dept. 4852, Box 7025, Colorado Springs, CO 80933

STYLE → ANY WORDING YOU WANT

Up to 17 letters & numbers on long plate - 6 on short plate

Ordered by _____

Address _____

City-State-Zip _____

Check here to receive details on fund raising!

To use your bank charge card, please fill out the boxes below.

BANKAMERICARD MasterCard

BankAmericard No. _____

Master Charge Credit Card No. _____

Expiration Date _____

Month Year _____

Master Charge Interbank No. _____

PRICE \$ _____

ADD POSTAGE & HANDLING \$1.65

TOTAL \$ _____

DAY OR NIGHT SLEEP BETTER

WITH THESE SLEEP SHADE AIDS

THE BEAUTY SLEEP® SHADE EYE MASK is specially fashioned from fine satin. It covers your eyes in style and insures total darkness and comfort.

PASTEL & JEWEL TONES, ALL SATIN (State Choice of color) **\$7.50**

(PASTEL - Pink, Blue, Green, Yellow. JEWEL TONES - Midnight Blue, Royal Blue, Forest Green, Burgundy, Crimson)

The fine quality and unique design of the SLEEP SHADE® EYE MASK has been giving sleeping satisfaction to thousands for over 40 years.

It's comfortable and easy to wear. SLEEP SHADE® EYE MASK provides complete darkness for sound sleep.

DELUXE ALL BLACK ACETATE SATIN **\$6.00**
REGULAR, SATIN AND SATEEN **\$5.00**

Pstg. and hdlg. 75c, each add. pkg. 50c
SLEEPWELL® EAR STOPS are another great sleeping aid. They are soft, so they fit your ears easily and they are re-useable. If you want to eliminate noise—day or night—try SLEEPWELL®.

1 Pair 60¢, 6 pair in Box—\$3.00 (Pstg. & hdlg. 25c; each add. pkg. 20c)
If your Drug or Dept. Store cannot supply you, we will mail immediately upon receipt of M.O. or check. Calif. res. add sales tax.

SLEEP SHADE COMPANY
PO Box 968, Dept. E, 1089 Mission St.
San Francisco, CA 94101

See Advertisement on Inside Back Cover

HABAND'S 100% MAN-MADE IN U.S.A.

Dress BOOT & SHOE OFFER **2 Pairs for 2495**

HABAND COMPANY **3 Pair \$36.50**
265 N. 9th St., Paterson, NJ 07530

Sirs: Please send.....pairs. Full remittance of \$.....is enclosed and will be refunded at once if upon receipt I don't want to keep and wear these shoes. 72A-459

Color - Style	Size	Width
Brown Boot		
Black Boot		
Reptile Loafer		
Black Loafer		
Ginger Loafer		
Black Oxford		
Dark Brown Loafer		

Mr. _____
Street _____
City _____
State _____ Zip _____

Haband by U.S. Mail since 1925

EASY-LIFT



LIKE A HELPING HAND.

Many people—senior citizens, arthritics, and those suffering from Multiple Sclerosis, Muscular Dystrophy or Parkinson's disease—need help getting in and out of a chair. The EASY-LIFT power cushion recliner gently lifts you forward as well as up to a semi-standing position. The lifting angle adjusts to fit your needs, controls are easy to reach, and it runs on household current. EASY-LIFT—like a helping hand.

WRITE FOR FREE BROCHURE
AND NAME OF DEALER NEAREST YOU.

AMERICAN STAIR-GLIDE CORP.

4001 East 138th Street, Dept. EE-88
Grandview, Missouri 64030

See Advertisement on Inside Front Cover

SENIOR MAN EXECUTIVE DRESS SLACKS **2 Pairs For 1995** 3 For \$29.85

4 For \$37.90; All 5 Pairs for \$49.50
HABAND COMPANY, Special Service Dept.
265 N. 9th St., Paterson, NJ 07530

OK, Haband, I want to try.....pairs of your new Executive Cut SENIOR MAN Slacks. My size and color choices are below and I enclose my remittance of \$.....

GUARANTEE: If upon receipt I do not choose to wear the slacks I may return them within 30 days for full refund of every penny I paid you. 72B-068

COLOR	How Many	Waist	Inseam
Blue			
Brown			
Grey			
Forest Green			
Burgundy			

Name _____
Street _____ Apt. No. _____
City _____
State _____ Zip Code _____

We promise FAST RELIABLE SERVICE

STOPS YOUR ROOF LEAK

In Just 5 Minutes!

It's pouring rain and your warm, dry home is invaded by a slow drip, drip, drip of water leaking through your roof. You call your local roofer and are shocked to learn how much roofing repairs cost these days.

While you wait for the next rain to come, the wife is worried about the new sofa being ruined from the down pour of rain water . . . from your leaky roof . . .

But, now at last, the new and truly revolutionary *U.S. Polycoat Roof Coating!* Imagine! A coating so efficient, so unique, that it waterproofs and protects your roof from rains or snow all year long. U.S. POLYCOAT can be brushed or rolled on over almost any surface and dries to a rubber sheet-like film in minutes—no heating—no mixing—use straight from the can. U.S. Polycoat adheres to asphalt shingles, rolled roofing, wood, brick, plywood, cement, tar, aluminum, metal, asbestos, insulation board and even urethane foam. U.S. Polycoat comes in seven colors to match your roof.

U.S. Polycoat protects driveways, sidewalks, patios, mobile homes and parking areas, too. But, if your roof is leaking send for U.S. Polycoat today. You'll have a worry-free waterproof roof that will last for years and years. Waterproof with U.S. Polycoat before you insulate!

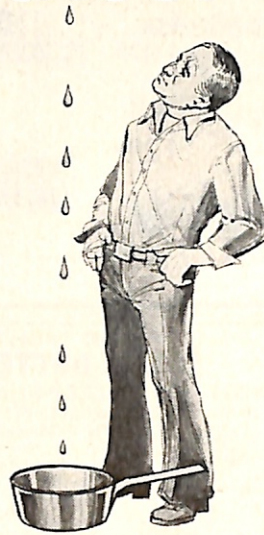

U.S. POLYCOAT, INC., 7316 N. Monticello • Skokie, Illinois 60076 • (312) 675-3666

MAIL TODAY

U.S. POLYCOAT INC. Dept. E88

7316 N. Monticello • Skokie, Illinois 60076

Gentlemen: Please rush me _____ gallons of U.S. Polycoat.

1 Gal. - \$12.95 2 Gal. - \$24.90 5 Gal. Bucket - \$59.75 Include \$1.50 Per Gallon for Postage and Handling. Enclosed is

Check Money Order or total of \$ _____
 Charge my order to VISA/Bank Americard

Color Clear Silver Black White Green Red Brown

One gallon covers approx. 50 to 100 square feet. Two gallons covers approx. 100 to 200 square feet. Five gallons cover approx. 250 to 500 square feet. Coverage depends on type of surface.

Print Name _____

Address _____

City _____

State _____

Zip _____

DEALER AND APPLICATORS INQUIRIES INVITED • (312) 675-3666

© 1977, U.S. Polycoat

Elks Family Shopper consumer/news

officer in the school you want to attend, or from the Division of Student Support and Special Programs, Bureau of Postsecondary Education, Office of Education, Department of Health, Education and Welfare, 400 Maryland Ave., Washington, DC 20202.

The publication also includes a listing of other federal programs to help you go back to school, complete with where to write and phone.

There's also a listing of non-government sources of information on education for people ready to move on and explore new things, or broaden a background.

A new consumer booklet in plain language has been prepared by the health insurance industry for persons over 65 who want to supplement their Medicare coverage.

Single copies of the booklet are available free. Write for: *Retirement Health Insurance Booklet*, The Health Insurance Institute, Department RH, 1850 K Street, N.W., Washington, DC 20006. ■

Oh! the MONEY

in Hanover shoes!

Put another \$200 in your pocket next month with a Hanover Shoe sideline as your extra moneymaker. And get a free pair of shoes while you're at it!

Show friends and neighbors how to save more than \$15 per pair on . . . dress shoes, casuals or work shoes. Top quality, fine leathers, over 200 modern styles to choose from.

Show the picture-selling Hanover catalog evenings, weekends, lunch hours. Don't sell. Let them buy!

Pocket your high commissions, wear your free shoes. FREE catalog and sales kit for 30-day no-obligation trial.

No salesman will call.

MAIL
FREE TRIAL
COUPON

- The Hanover Shoe, Inc.
- Dept. 2112 Hanover, Pa. 17331
- Please send catalog and sales kit for 30-day
- FREE TRIAL. I am under no obligation. No
- salesman will call.

● Name _____

● Address _____

● City _____ State/Zip _____

● EK-88GL, 811 Wyandotte, Kansas City, Missouri 64105.

NOW! GET 3 REAL OLD MERCURY DIMES-ONLY \$1.



Only \$1 brings you 3 real silver Mercury Dimes issued before 1946. (One set to a customer.) These scarce coins are completely out of circulation. You will also receive wonderful price lists of U.S. and foreign coins and paper money. Offer to ADULTS ONLY. Send \$1, name, address, zip to: Littleton Coin Co., Dept. DM-78, Littleton, New Hampshire 03561.

MAGNIFYING READING GLASSES \$5⁹⁸



High-quality, plano-convex lenses in stylish smoke-color frames magnify fine print, make it easier to do close, precision work. Metal hinges for long wear. For folks over 40 without eye disease or astigmatism who simply need magnifying lenses. Order on 30-day money-back trial. If not satisfied, return postpaid for full refund. An outstanding value at \$5.98. State age, sex. Add 90c postage. NEL-KING PRODUCTS, Dept.

EK-88GL, 811 Wyandotte, Kansas City, Missouri 64105.

We're Doing Something . . .

(Continued from page 6)

The drought had been doing wonders for their tomatoes and melons. Now the man-made rains had blighted their crops. Who would pay?

In the late 1960s, barley growers in Colorado's San Luis Valley commissioned a weather modification firm to improve their crops by upping rainfall early in the growing season, suppressing hail in midsummer, and suppressing rain during the season's final weeks. Cattlemen and lettuce and potato farmers hit the roof, claiming the weather modifications were damaging their crops. By 1972 the controversy had become so emotional that someone blew up the weather modifiers' radar trailer.

Even if the decision to make rain or suppress hail is left to a county's voters—as it is in South Dakota—who protects those whom the decision harms? “No one,” says Dr. J. Eugene Haas. “There is no established mechanism or institutional arrangement in our society which protects the rights of such a minority.”

“Any individual or business firm believing that damage has occurred due to cloud seeding faces an almost insurmountable set of requirements in the search for compensation,” he adds.

As Dr. Charles L. Hosler, of Pennsylvania State University, puts it: “While the morality of the Prophet Samuel in calling upon the Lord to bring down the lightning and the thunder and the hail to smite the Philistines and drive them away in disarray might never have been seriously contested in Sabbath or Sunday School, perhaps the Philistine point of view was never adequately presented.”

To date, he says, over half the states have weather modification laws. But they don't solve the riddle: “Who owns the clouds?”

Congress has generated over 70 weather-control bills and resolutions since 1946, reports John Hussey, professional staff member of the Senate Subcommittee on Oceans and Atmosphere. Because weather is interstate and international, most legal experts believe the Federal government must be the chief regulator of weather-modification efforts, he adds.

But what if Brazil decides to level the vast Amazon rain forest, altering the weather in Mexico? What if the Soviets do coat the Arctic icecap with soot?

Two weather modification researchers—Dr. William Kellogg and Dr. Stephan H. Schneider, both of the National Center for Atmospheric Research—advocate “No-Fault Climate Disaster Insurance.” They argue that anyone wishing to change the climate, whether it's Idaho potato farmers or the U.S.S.R.,

must first ante up a suitable insurance fund to recompense everyone whom the climate change hurts.

Says Howard J. Taubenfeld, director of the Institute of Aerospace Law at Southern Methodist University: “The elements have no interest in boundaries, private or governmental. Attempts to alter the behavior of clouds have brought gunfire and court suits between neighbors in this country; efforts to alter major weather patterns may in time to come be a *casus belli* in international affairs.”

Nevertheless, mankind will continue trying to tinker with the clouds. As scientist Stephan Schneider points out, men and women have as much curiosity as cats. And he argues that, since we already inadvertently alter the weather with our cities and industries, we had better learn precisely what is happening in weather modification. Besides, he says, our best defense against secret weather modifications by enemy nations is widespread understanding of how they might be carried out.

The National Academy of Science has issued a study urging \$50-million per year for weather control research and pinpointing these national goals:

- ✓ Identify by 1980 the conditions in which precipitation can be manipulated.
- ✓ Develop by 1980 ways of taming

hurricanes, hail, fog, and lightning.

✓ Launch a coordinated national and international effort to discover by 1980 pollution's effects on world climate and local weather.

And what of the average Joe or Ivan? Will he have a say in what the clouds bring forth?

Ecologist Charles Cooper, of San Diego State College, has said: “I predict that weather modification will be one of the first technologies over which the general public, rather than the scientist who devised the technology and the economic interests who see the immediate benefit, will exert control.”

Stanley A. Changnon, of the Illinois State Water Survey, has observed that “decisions regarding use and application of weather modification will be made increasingly by the general public and not by scientists.”

But what if Farmer Brown wants rain and resort-owner Smith wants sun? Apparently, we'll have to solve such problems en route. For weather control researchers are hard at work.

As Charles L. Hosler puts it: “Notwithstanding our lack of legal guidelines, no experiment contemplated thus far could produce permanent or cataclysmic results—thus, research can be vigorously pursued.”

Not so many years from now, the weatherman on the TV evening news may do more than just make forecasts. He may answer requests. ■

Obituaries

SPECIAL DEPUTY John T. Raftis of Colville, WA, Lodge died June 15, 1978. District Deputy Grand Exalted Ruler for the East District in 1950-1951, Brother Raftis was a member of the GL Committee on Judiciary from 1958 to 1962 and served as its Chairman from 1962 to 1965. In 1970-1971 he was appointed to chair the GL Pardon Commission. After three terms, from 1966 to 1969, as a member of the GL Grand Forum, SDGER Raftis held the position of Chief Justice of the Forum from 1969 to 1971. For seven terms, since 1971, Brother Raftis was a Special Deputy Grand Exalted Ruler.

PAST DISTRICT DEPUTY Joseph C. Melillo died May 4, 1978. Brother Melillo, a member of Lyndhurst, NJ, Lodge, was District Deputy Grand Exalted Ruler for the Northeast District in 1944-1945.

PAST DISTRICT DEPUTY C. V. Thompson of Greensboro, NC, Lodge died recently. State President in 1969-1970, Brother Thompson held the office of District Deputy Grand Exalted Ruler for the Central District in 1961-1962.

PAST DISTRICT DEPUTY W. H. Forbes Jr. of Morehead City-Beaufort, NC, Lodge

died May 4, 1978. Brother Forbes was appointed District Deputy Grand Exalted Ruler for the East District in 1964-1965.

PAST DISTRICT DEPUTY Lou H. Turnbull of Southside Jacksonville, FL, Lodge died recently. In 1966-1967, Brother Turnbull was District Deputy Grand Exalted Ruler for the Northeast District.

PAST DISTRICT DEPUTY Otto Nemecek of Cicero-Berwyn, IL, Lodge died recently. Brother Nemecek served as District Deputy Grand Exalted Ruler for the state's Northeast District in 1964-1965 and was serving his 39th term as lodge Secretary at the time of his death.

PAST DISTRICT DEPUTY E. M. Odell died June 3, 1978. A member of Ithaca, NY, Lodge, Brother Odell served as District Deputy Grand Exalted Ruler in 1951-1952 for the South Central District.

PAST GRAND LODGE COMMITTEEMAN W. Ray Malone of Wellsburg, WV, Lodge died April 30, 1978. Brother Malone was District Deputy Grand Exalted Ruler in 1963-1964 for the North District and a member of the GL State Associations Committee in 1967-1968 and 1969-1970.



FRONTIER PHOTOGRAPHER

(Continued from page 12)

anything, the rumors were underexaggerations. Slowly, Jackson set up his equipment and exposed some 400 plates.

At this time the physical exposure took five minutes, which made it impossible to photograph the quick bursting geysers, so Jackson rigged his cameras with a rubber band shutter that could take a picture in 1/10 of a second. Still, there were problems setting up his equipment; often, by the time he fixed a glass plate with the necessary chemicals, the geyser had finished erupting.

Nature solved this problem for him. He found a geyser that erupted on schedule, once every hour. Jackson got his picture, and they now call this obliging geyser "Old Faithful."

Back in Washington, the photographs caused a sensation. It was the 19th Century equivalent of the televised landing on the moon. Immediately, work started to have Colter's Hell declared a National Park, but at the same time there was strong opposition to it; many people suddenly saw a chance for commercial opportunities in the valley, and didn't want the government closing them out. The vote in Congress could have gone either way, when, at just the right moment, Hayden presented each senator and representative with a handsomely bound portfolio of Jackson's photographs. The lobbying technique worked, and the bill passed Congress without a dissenting vote. In March, 1872, President Grant signed it, and Colter's Hell, now called Yellowstone, became the first National Park.

For Jackson it meant overnight fame—and a new problem. He was still a young man and had no intention of being forever labeled as the first man to photograph Yellowstone, but what could he possibly do to top it?

The answer came two years later in the Colorado Rockies. Because of Indian troubles up north—troubles that would eventually end in the Custer massacre—the survey was moved to Colorado. By now, everyone in the expedition was sensitive to rumors, and the most persistent one that summer concerned a mountain with a half-mile cross of snow imbedded in a sheer rock cliff. Everyone in Colorado had heard of the mountain, but when questioned, no one had actually seen it.

That didn't bother Jackson. He was so sure he would find it, he promised a photograph of it to his fiancé. However, the government wasn't paying him

to search for mythical mountains, so with the rest of the survey he spent most of the summer photographing real mountains and passes. Each morning the members of the expedition would get up at 3:30 a.m., cook breakfast, load up the mules, and be prepared to leave by first light. They would travel 10 to 15 miles, often over extremely rough country, and camp at noon. Here, each specialist would go out to collect fossils, gather plant samples, or map the area. Jackson was more or less free to go anywhere along the planned route and take pictures of what he thought captured the feel of the landscape. This usually entailed climbing up 14,000 foot peaks, hand carrying the heavy equipment up ledges that even mules would not climb.

Mules were both loved and hated on the survey. Jackson's first mule, Hypo, carried his equipment through Yellowstone without any problems; Dolly became his favorite riding mule and he used her for five years, but Gimlet, "an evil little mule," bucked up half way

them behind, Jackson and two assistants carried the heavy camera equipment up the rocky slope. Clouds came in, and soon the entire mountain was engulfed in a swirling sea of white. Jackson went on ahead and reached the top, when suddenly the clouds parted for an instant, and across the steep valley, a mile away, the huge cross was visible. By the time his men reached the top it was once again covered.

They spent the night up there, freezing without blankets or food, but in the morning the sun was bright and the skies clear and Jackson took eight photographs that would travel around the world. Henry Wadsworth Longfellow would hang one of the pictures in his living room and write a poem about it called "Cross of Snow;" another would win a medal at the Philadelphia Centennial Exposition of 1876. It is estimated that Jackson's first photo of the Mount of the Holy Cross was the most widely distributed and reproduced photo of the 19th Century. Certainly, no better photo of the cross was ever

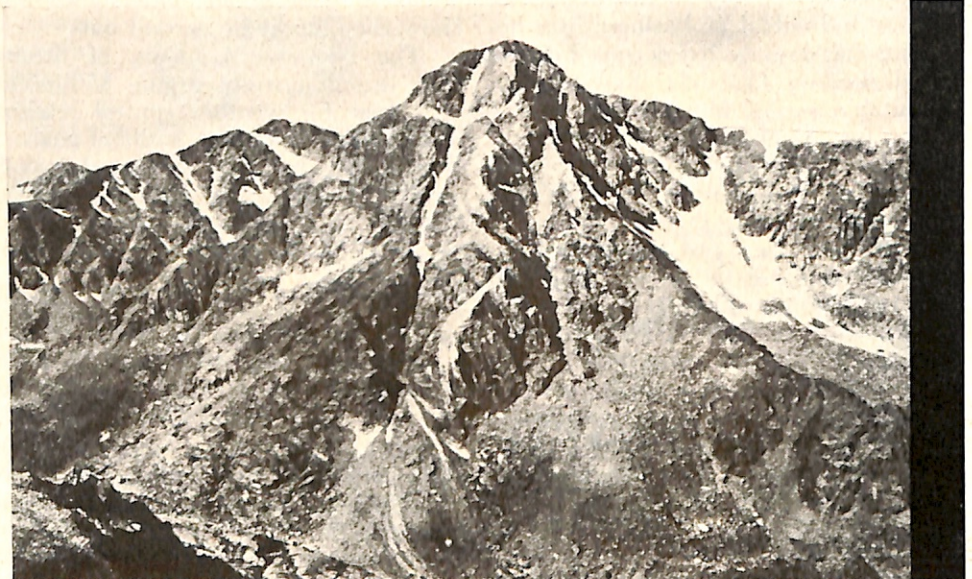

through the Colorado trip and broke many hard earned glass negatives. He had to re-shoot several weeks work.

There are a lot of legends concerning Jackson and the mountain with the cross of snow. One has it that the famous chief of the Utes, Ouray, told him where it was. Actually, Jackson saw it through field glasses from the top of Gray's Peak, and was able to tell pretty much where it should be. Hayden realized that finding and photographing the mountain would be good publicity for his survey, so they spent the last few weeks of the summer in search. As they got closer, it appeared that the reason no one ever saw the cross up close was that there was another mountain almost directly in front of it. They headed up this.

It was a steep and rough climb—the mules would have no part of it. Leaving

taken. Jackson tried again five times, and hundreds of photographers have climbed the steep mountain, but the condition of the cross changes each year and no one has ever caught it in better shape.

Though he lived to see the invention of color film and miniature cameras, his best work was done with the large, cumbersome cameras of the 19th Century. Hand carrying glass plates up rock ledges, using melted snow to develop his negatives on the spot, Jackson produced pictures that any modern photographer with the best equipment would be proud of.

At the age of 99 he was asked what he owed his longevity to.

"Well," he replied simply, "I did a lot of walking." Then he offered this advice: "Always have something interesting to do tomorrow." ■

INTRODUCTION TO BOOTS!

Take any Two Pairs of new dress shoes shown here. Take even Two Pairs of Boots!

ANY **2** PAIRS ONLY **24⁹⁵** IF YOU WILL BUY NOW!

And Get Acquainted with the "Added Comfort" collection of EXECUTIVE FASHION FOOTWEAR!



CHECK US OUT!
All Haband shoes are 100% man-made in U.S.A. and we ship them by the millions to men all over America. This is what they're wearing, and this direct 2 pairs for \$24.95 price just can't be beat! And it is EASY TO ORDER

FEEL the BUILT-IN CUSHION-STEP!
(You'll be amazed at the difference!)

New! SIDE ZIPPER BOOT is very easy to Step In, Zip Up, and Show Off! Men who first wore boots for extra comfort are now the style leaders. Even in the Executive Suite! Now get fast reliable service in your Exact Size and Width. Order NOW!

Brown or Black Boots



New! Reptile Grain Loafer

Black Loafer

New! Ginger Loafer

Black Oxford

Dark Brown Loafer

Attention:

Have you seen what has happened to good men's shoes? Your best old favorites can be badly out-of-date. In fact, most men are turning to BOOTS! Very comfortable. But they cost like sin!

Now Haband, the mail order people from Paterson, N.J., have a welcome Introductory Offer: Buy NOW and you get Any Two Pairs of the fine shoes shown here - EVEN TWO PAIRS OF BOOTS - at the astounding low price of 2 pairs for \$24.95! That's less than the price of one pair of boots alone in most stores!

And they are well built shoes! 100% man-made in U.S.A. with life-of-the-shoe one-piece heel and sole, good strong heel counters, flexible built-in support shank in the arch. Hidden elastic gore in the step-in loafers. Easy-on side zipper in the Boots. Inside heel cushion. The Works! And tough new uppers that scoff at scuff and keep a good dressy shine, even in the rain!

Easy "TRY 'EM ON" Offer! Haband serves over 2-million customers, direct by U.S. Mail, and we have a huge inventory of the styles shown here, all ready to go! We will be proud to send you any two pairs you'd like to try, for your convenient At-Home Inspection. You try them on, then decide. Two pair for \$24.95! Just tell us what size, on this NO RISK order form.

HABAND COMPANY • 265 North 9th Street Paterson, New Jersey 07530

Haband's 100% man-made in U.S.A. **Dress BOOT & SHOE OFFER** **2** Pairs for **24⁹⁵** 3 Pair 36.50

HABAND COMPANY
265 N 9th Street
Paterson, NJ 07530

Sirs: Please send pairs.
Full remittance of \$ is enclosed and will
be refunded at once if upon receipt I don't want to keep and wear these shoes.

72A-459

Mr.
Street
City
State Zip

Haband by U.S. Mail since 1925

IS YOUR SIZE ON THIS CHART?

	5	6	6 1/2	7	7 1/2	8	8 1/2	9	9 1/2	10	10 1/2	11	11 1/2	12
A														
B														
C														
D														
E														
EEE														

Color/Style	Size	Width
Brown Boot		
Black Boot		
Reptile Loafer		
Black Loafer		
Ginger Loafer		
Black Oxford		
Dk Brown Loafer		

Seven & Seven. Great taste you can count on.

Put the great taste of Seagram's 7 and 7-Up together, and you've got a classic: Seagram's 7 & 7. Just pour 1½ oz. Seagram's 7 over ice in a tall glass and fill with 7-Up. Great taste you can count on!

Seagram's 7 Crown
Where quality drinks begin.

