

Bike Racing Makes A Comeback

the
Elks
magazine
JULY 1978

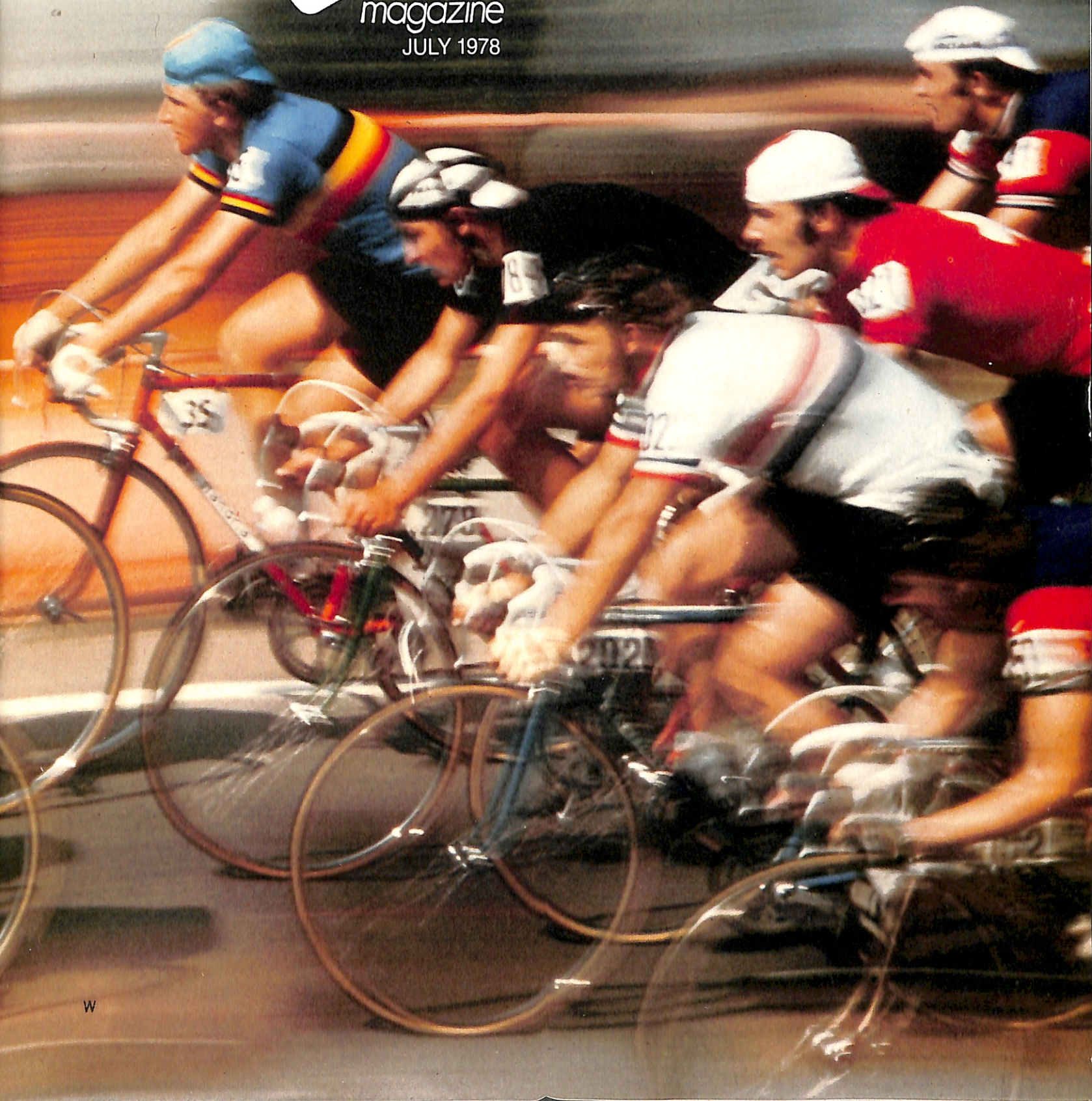

**Rugged...Elegant...The Boot
For The Man Who Is Going Places!**

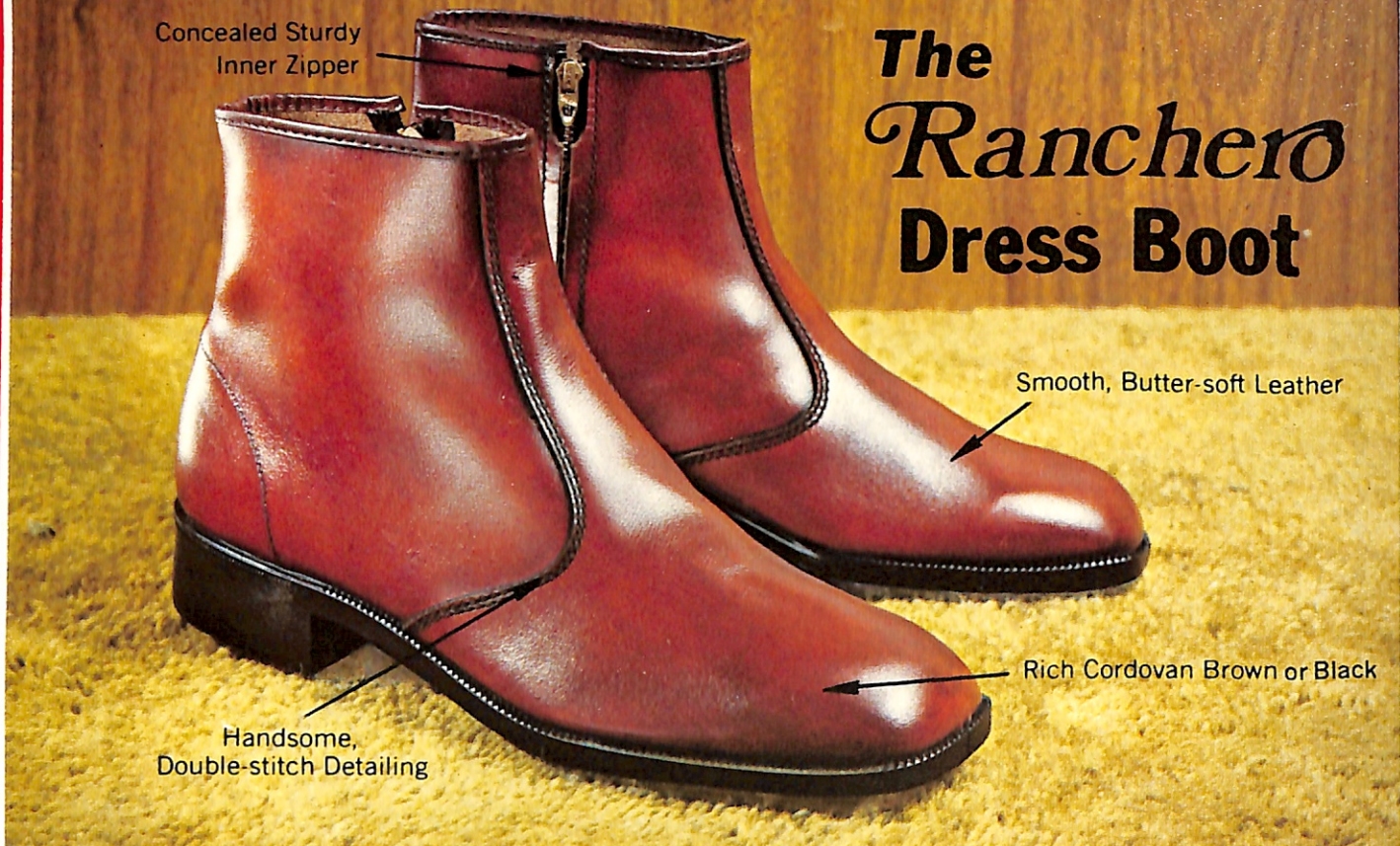

**The
Ranchero
Dress Boot**

Genuine Leather

Not ~~\$49.95~~ Not ~~\$29.95~~

Only \$19⁹⁵

- Cobbler-Crafted • American Made
- Long-wearing Composition Sole and Heel

TRY THEM AT OUR RISK!
Return Within 14 Days
For Money Back

Here's the town boot of the range-riding Westerner...rugged, uncluttered, no-nonsense. No wonder the man of style has adopted it for his versatile way of life! The bold, square-toed detailing goes great with sports clothes and jeans and the sleek, lean design gives a "with it" look to the business suit.

This Season's Dress Boot

You'll wear these boots every day, everywhere. They're hard to beat for comfort. The supple leather breathes and the high shaft cradles ankles. There's a concealed inner zipper so the boot slips on and off as easily as a loafer. Man-made sole and heel really stand up to wear and tear. Don't miss the chance to get this season's best boot buy at an incredibly low price!

Men's Sizes: 7½, 8, 8½, 9, 9½, 10, 10½, 11, 12

Widths: C, D, E **Colors:** Cordovan Brown, Black



OLD VILLAGE SHOP

Hanover, Pa. 17331

— Satisfaction Guaranteed! Mail Coupon Today —

OLD VILLAGE SHOP, Dept. M-3546
340 Poplar Street, Hanover, Pa. 17331

Please rush _____ prs. of the Genuine Leather "Ranchero" Dress Boot for the low price of just \$19.95 pr. plus \$1.75 postage and handling on same money-back guarantee.

SAVE MORE! Order two pairs for just \$38.00 plus \$3.25 postage and handling on same money-back guarantee.

____ prs. Cordovan Brown (M246470B) Size _____ Width _____
 ____ prs. Black (M236356B) Size _____ Width _____

CHARGE IT:

American Express Carte Blanche Master Charge
 BankAmericard/Visa Diners' Club Interbank # _____

Acc't # _____ Exp. Date _____

C.O.D. (Enclose \$2.00 deposit per pair) Enclosed is \$ _____

PRINT NAME _____
 ADDRESS _____
 CITY _____
 STATE _____ ZIP _____

A message from the
Grand Exalted Ruler

RESPONSIBILITY RESULTS REWARDS

This year is nearly finished and the record written, but it would be incomplete without expressing, on behalf of Jo and myself, our heartfelt thanks to those who have done so much for us during our year of service. Your kindness and understanding will be forever in our hearts.

Thanks to the thousands of Elks who so gladly assumed individual responsibility, our Order has completed a year of splendid progress. The reports are all in. It is pleasant to be able to say that they show advances in every area of our fraternity's activities.

Last August I invited every member to pitch in and be a part of Elksdom in some of the many constructive ways open to us all. The response has been nothing short of tremendous as reflected in the gains in membership, in the heart-warming support given to our Elks National Foundation and to our program supporting our hospitalized veterans. This support has been so apparent in the enthusiastic participation in our ever-broadening youth activities and in our inspiring projects for the benefit of those who are handicapped.

Such bottom line statistics are pleasant reading. But there is something that is more important than numbers. That's the knowledge that the Order of Elks has grown stronger and better because of the added investment by so many of our Brothers in time, labor, ideas and money. It has been a very deep pleasure to recognize so many through award of membership card seals and lapel pins. Yet I have no doubt that far more rewarding to them has been their satisfaction in their personal involvement.

Now, my term draws to a close, and the administration of our Order will be turned over to another as it has been done for so many years. I am completely confident that, in our long tradition of building upon the past, we shall go forward to achieve "Continued Commitment to Effort and Enthusiasm".

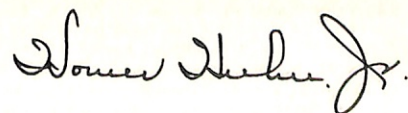

Homer Huhn, Jr.



**"Individual
Responsibility
Assures Progress"**



INVEST IN YOURSELF



Become a Western Auto Associate Store Owner, a partner with one of America's largest retail chains, Western Auto Associate Stores.

- Backed by 42 years of successful Associate Store experience.
- No contract or franchise fee or sales royalty ever.
- Monthly hard hitting sales circulars available.
- Extensive T.V. coverage in most markets at no cost.
- Regular Western Auto truck delivery to most stores.
- Customer credit financing plan available for your customers.
- Associate Store Owner credit programs expand your investment dollars.
- Training in retail store management provided.
- Personal help through regular visits from Territory Sales Manager.
- Investment varies with market. Minimum \$40,000.

Fill in the coupon for more information.

Send to R. T. Renfro, V.P.
Western Auto
2107 Grand Avenue
Kansas City, MO 64108



Name _____

Address _____

City _____

State _____ Zip _____

Phone - Area Code () _____



the Elks magazine

VOL. 57, NO. 2 / JULY, 1978

NATIONAL PUBLICATION OF THE BENEVOLENT AND PROTECTIVE ORDER OF ELKS OF THE UNITED STATES OF AMERICA. PUBLISHED UNDER THE DIRECTION OF THE GRAND LODGE BY THE NATIONAL MEMORIAL AND PUBLICATION COMMISSION.

THE ELKS NATIONAL MEMORIAL AND PUBLICATION COMMISSION

WADE H. KEPNER/Chairman
R. LEONARD BUSH/Vice-Chairman
RAYMOND C. DOBSON/Secretary
EDWARD W. McCABE/Treasurer
ROBERT E. BONEY/Asst. Secretary and Asst. Treasurer

JOHN R. RYAN/Publisher/General Manager
JEFFREY BALL/Managing Editor
MARY M. CAVANAGH/Fraternal News Editor
MALCOLM B. CROFFORD/Circulation Manager
EDITORIAL OFFICES, 425 W. Diversey Parkway, Chicago, IL 60614

- 4 **A Nation of Runaways** George Harrar
America is fast becoming a nation of runaway—and throwaway—children at the rate of over a million a year.
- 8 **Bike Racing Makes A Comeback** Robert Bahr
A few years from now you may be sipping a cocktail and gazing through the tinted glass of a plush lounge, watching the most spellbinding race you've ever seen . . .
- 20 **Quincy: A Bone of Contention** Warren H. Spencer
Throughout the nation, those certified by the American Academy of Forensic Sciences—all 20 or so—know that Quincy just can't do the things he does.
- 24 **The Extras Are Extra** Audrey and Harvey Bilker
It was a quiet day at the auto agency. Until the stranger walked in to order a car with every extra—except the engine.

Departments

- 1 Message
- 11 It's Your Business: Starting New
- 12 Major Projects: MN/IN
- 13 News of the Lodges
- 17 Travel: Hawaii
- 18 Elks National Foundation/
Joy of Giving
- 19 Medicine and You: Savage Sun
- 23 You and Retirement:
Health Insurance
- 27 Elks National Service Commission
- 29 Letters
- 31 The Fraternal Corner
- 33 Visits of Homer Huhn, Jr.
- 38 Elks Family Shopper/More
For Your Money

Cover: Olympic Cycling Thomas Zimmermann

ADVERTISING OFFICES



CHICAGO 60614 425 W. Diversey Parkway (312) 528-4500
NEW YORK 10017 50 East 42nd (212) 682-2810

THE ELKS MAGAZINE, Circulation Dept., 425 Diversey Parkway, Chicago, IL 60614

MEMBERS: Changes of address should be made through your lodge Secretary. Give him advance notice of at least 30 days. Remember that the day you write, your next copy is already in the mails. Before you move, file your new address at the post office to have mail forwarded. In writing to us regarding an address change, please give: Full name, lodge number, membership number, address to which copy is being mailed, and complete new address. Attach label from recent issue if available. Please show ZIP Code numbers in both old and new address.

THE ELKS MAGAZINE, Volume 57, No. 2, July, 1978. Published monthly at 425 W. Diversey Pkwy., Chicago, IL 60614 by the Benevolent and Protective Order of Elks of the United States of America. Second class postage paid at Chicago, IL, and at additional mailing office. Acceptance for mailing at special rate of postage provided for in Section 1103, Act of October 3, 1917, authorized May 20, 1922. Single copy price 25 cents. Subscription price in the United States and its Possessions, for Elks, \$1.25 a year, for non-Elks, \$2.50 a year; for Canadian and Foreign postage, add \$1.00 a year. Subscriptions are payable in advance. Manuscripts must be typewritten and accompanied by sufficient postage for their return via first class mail. They will be handled with care but this magazine assumes no responsibility for their safety.

The word, Elks, is a registered trademark of The Benevolent and Protective Order of Elks of the United States of America. Copyright, 1978, by the Benevolent and Protective Order of Elks of the United States of America

THE INCREDIBLE ★ ASTOUNDING ★ WORLD FAMOUS

ASTRO-TRIMMER™

THE ONLY WAIST AND TUMMY REDUCER THAT CAN PRODUCE RESULTS LIKE THESE

★ "Lost 4½ inches from waistline the first day!"

M. Morgan

★ "Total of 9 inches off waist and abdomen-one day!"

M. Meyers

★ "Nearly 5 inches off waistline in less than 1 hour!"

J. Stewart

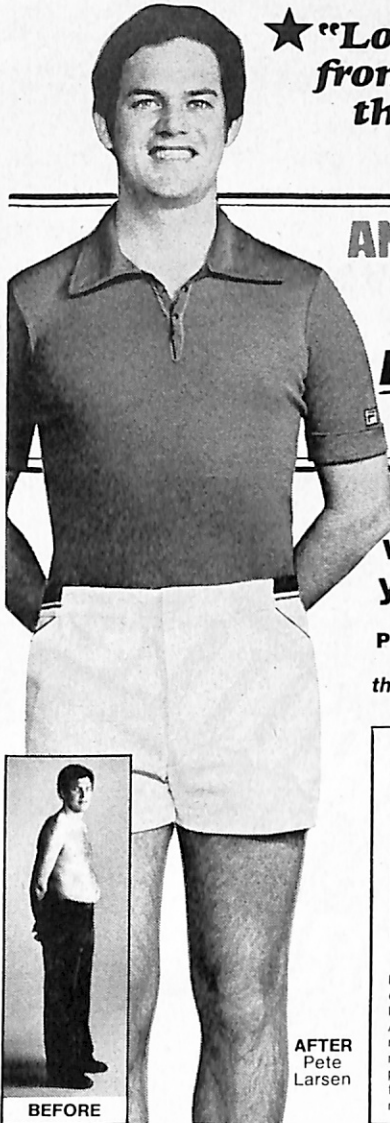

AND NOW ASTRO-TRIMMER GUARANTEES YOU WILL LOSE 4 TO 8 INCHES FROM YOUR WAIST AND ABDOMEN IN JUST ONE DAY-WITHOUT DIETING ★ OR YOUR MONEY BACK ★

Yes, you must lose 4 to 8 inches from your waist and abdomen the very first time you use your Astro-Trimmer or it won't cost you a cent.

Pete Larsen: "I lost over 4" from my waistline the very first time I used the Astro-Trimmer - without dieting!"

"Astro-Trimmer took 5 inches off my waist, 4 inches off my tummy in just one day - and no dieting!" Jeanette Ayers

HERE IS HOW IT WORKS:



BEFORE

AFTER Pete Larsen

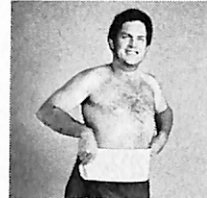

Pete wraps the Astro-Belt completely around his waistline, before hooking the Astro-Bands to a convenient doorway. He is then ready to perform one of the pleasant, marvelously effective Astro-Trimmer movements - just about 10 minutes.

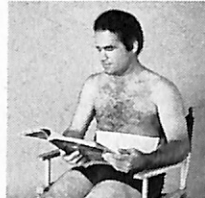

Now Pete simply relaxes a few moments with his Astro-Belt in place. His Astro-Trimmer movements have triggered the Astro-Belt's incredible inch-reducing effect which goes on working even as he relaxes.

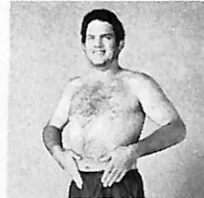

After his brief period of relaxation, Pete removes his Astro-Belt. His waistline is already tighter and trimmer. Pete lost 4-1/2 inches on his waistline the very first day with Astro-Trimmer, the only waistline reducer that makes such results possible!

AFTER Jeanette Ayers



BEFORE

Startling discovery - the Astro-Trimmer has got to be the most sensationally effective and the most fun to use slenderizer of all time. It is a marvel of ease, comfort and efficiency - and a pure joy to use. The Astro-Trimmer's totally unique design consists of a double layered belt; a soft nonporous inner thermal liner which wraps completely around your mid-section producing a marvelous feeling of warmth and support - and a sturdy outer belt that attaches you to the super duo-stretch Astro-Bands which you hook to any convenient doorway. These duo-stretch bands enhance your slightest movements and transmit their effect - greatly magnified - directly to the inner thermal liner of the belt to produce an absolutely unequalled inch-reducing effect. In fact, for sheer inch loss, the Astro-Trimmer is supreme. Try it for yourself - at our risk - just slip on the belt, hook it up, stretch and perform one of the easy-to-do movements in the instruction booklet and watch the inches roll off. Men and women from 17 to 70 are achieving sensational results from this ultimate inch-reducer.

How many excess inches can I lose with the Astro-Trimmer? How many excess inches do you have? As you can see many users are losing 3, 4 or even more inches from their waistlines and from their abdomens the very first day. Not everyone will do this. The degree of inch loss will vary with individual body response. However, this matchless body shaper melts excess inches off the waist, abdomen, hips and thighs with such amazing speed that if you do not lose 2 to 4 inches from your waistline and 2 to 4 inches from your abdomen without dieting in just one day you may simply return your Astro-Trimmer and your money will be refunded.

No risk - no obligation - money back guarantee. So-called "waist trimmers" and reducers have been nationally advertised for as much as \$19.95 and more. Yet the sensational new Astro-Trimmer which trims and slims excess inches far faster, far more effectively than anything we have ever seen - is being offered for only \$9.95 with a complete money back guarantee. If you are not satisfied that the Astro-Trimmer is the fastest, the most effective waist reducer you have ever used, it will not cost you a penny. So if you want a trimmer, ideally proportioned body - right now - send for your Astro-Trimmer today.

ORDER NOW FOR A SLIMMER, TRIMMER WAISTLINE THIS WEEK!

ASTRO-TRIMMER™ P.O. Box 3140, Dept. EK-9, Monterey, Ca. 93940

Please send me my results are guaranteed and, if within 2 weeks I am not completely satisfied, I can return my Astro-Trimmer and get my purchase price immediately refunded. **PLEASE CHARGE TO MY:**

Check Money Order COD's accepted Visa MasterCard BankAmericard

Charge Account No. _____ Man Waist Size _____ Exo Date _____
 Name _____ Address _____ City _____ State _____ Zip _____
 Woman Waist Size _____

PATENTED © Copyright Astro-Trimmer 1978
 Highway 1 and Callendar Road, Arroyo Grande, CA 93420

by George Harrar



Mark's mother handed him \$20 and a plane ticket to anywhere, anywhere but home.

© Lenny "boogied" from his 15th foster family in 14 years, looking as always, for a "good mother and father."

© Beth ran from the physical discipline of a private boarding school to home, but her parents turned her away.

America is fast growing into a nation of runaway—and throwaway—children.

The FBI's Uniform Crime Report Section counts 250,000 persons under 18 taken into custody each year for running away. Field workers counseling and caring for runaways daily estimate that four to ten times the FBI figure—one to two million youngsters—take to the road annually in what has become our culture's rite of passage.

Stealing away in circus wagons as they rumbled out of town . . . joining the navy at barely 16 . . . riding the rails on midnight boxcars—this country was nurtured on the Huck Finn spirit of recklessness and adventure.

But the realities of 1978 temper all the glamor and romanticism of yesterday's wanderlust life. Pimps and prostitutes, drugs and alcohol, panhandling and stealing—there is too much out there for a child eight-years old to handle.

Eight?

At that tender age a Michigan boy set off from home and was found two days later 1000 miles away, in Florida. The wonder of such an odyssey is that anyone would unquestioningly transport this miniature hitchhiker.

Most eight-year olds run, if at all, only as far as an empty stomach will take them. But if the trend in the next decade follows those of the decade past, there may indeed come a time when flight from home is not uncommon in the under-ten set.

For the moment though, the "average" runaway is all of 16.2 years of age. The statistical runaway is also white, middle class and female. A parent-child conflict is the basic reason for running away while a family argument is the precipitating event.

The typical runaway stays on the road for no more than three days at a time and does not cross over her state borders. She is reconciled to her home situation physically, which is not to say the root cause of her running away is solved.

She is most often the first born of a four-child family where the parents are divorced, or at best, living together on an off-on basis. She is not dependent on drugs, using marijuana moderately. She probably has had no prior confrontation with the law.

Un-statistically speaking, the runaway is alone, vulnerable, desperate and unsure what to do next. She is looking for an answer, a way to go, whether it comes from a pimp, pusher or peer, or someone else on the straight side of the law.

More than ever before, agencies exist to shelter, counsel and feed the runaway. It wasn't always so.

The year 1974 was the turning point in government recognition of the problem and, more importantly, funding of a solution.

The first bold step involved a grant under Congress' 1974 Runaway Youth Act to Metro-Help, a Chicago-based crisis intervention agency. The idea was to give runaways anywhere in the country one place to turn for information and advice.

So Metro-Help founded the National Runaway Switchboard (800-621-4000; 800-972-6004 in Illinois). With toll-free WATS lines at its core, the switchboard acts as a communication link between the frightened runaway and his equally frightened parents. If the runaway doesn't want to contact his parents, then Metro-Help guides him to social service agencies near where he is calling from.

Eighty-five volunteers and eight full-time staff undergo 45 training hours each in counseling techniques before taking a seat at the phones. Some days it is a distinctly hot seat.

One frantic girl called a runaway switchboard in the midst of giving herself an abortion. She passed out before giving the number of her phone booth.

Armed only with a town name, the hotline operator contacted local police who canvassed the main streets until they located, and saved, the girl.

Though National Runaway Switchboard operators are taught to handle the occasional life-threatening emergency, it is talking to and understanding the runaway during the typical 13-minute conversation that is the bulk of the work. The better the understanding, the better the advice that can be offered.

This emphasis on counseling is the major difference between the National Runaway Switchboard and its Houston-

based companion (not competitor) in the field, Peace of Mind.

The digging up of 27 bodies—mostly young boys—in that Texas city during 1973 triggered thousands of calls from across the country. Invariably the anxious parents began, "My son has run away. Could he be among the dead?"

Two Houston women sympathized with the anguish of parents thousands of miles away who wouldn't get a clear answer to their fears through normal channels. These women sought 30-day funding from the governor's office in Austin for two WATS lines to handle the influx of calls, to provide what peace of mind they could.

Three years later, Peace of Mind has found itself too needed to disband, coping with five to six thousand calls a month.

Volunteers do not advise, coax or cajole a youngster in any direction. The Houston hotline serves either as intermediary in blind messages between child and parent, or to a lesser extent, as a referral operation, supplying names and numbers of community agencies.

One such agency is Boston's Project Place. In 1967, two seminarians at Harvard's Divinity School felt the strong compassion for stray youngsters that many people reserve only for stray dogs or cats. The Divinity students took street kids into their apartment, providing a roof over their heads, a mattress underneath, and a lot of understanding in between.

This spontaneous "crash pad" grew physically and financially after being incorporated under the community action agency, Project Place. Since 1974, the Runaway Youth Act has funneled \$140,000 yearly through the Office of Youth Development to Project Place, and about \$7 million more yearly to 129 other shelters for runaways.

The five-story "house" in the heart of Boston is indistinguishable in the rows of brick and brownstone apartments. There is no sign calling attention to the young who flock there having no other place to go. A good reputation on the street and word-of-mouth are all the advertisement needed to keep the shelter running at peak capacity, about 15 youngsters.

Ask along the old cowpaths of Boston Common, inside the Park Street bus depots any late night, or in the alleys of the Combat Zone—the city's adult entertainment district—and the word is "try Project Place" for a place to stay, a meal, advice.



Getting a youngster into the Marlborough Street shelter the first night is no great accomplishment. Keeping him the second day is.

Out of fear, uncertainty and general youthful energy, the runaway is often compulsively restless. Some release for all the pent-up emotion is of prime importance, and at Project Place it is simply a punching bag.

The jangle of the support chain and the thud of the heavy-weighted bag resound through the building as boy after girl assaults the bag with karate kicks, punches and screams. They take turns punching, then light cigarettes for each other, two boys and one girl, teasing and laughing as familiarly as siblings.

Lenny has borrowed a jacket to go out, but when he hears there is a reporter about he clings to my side till I agree he may tell his story first.

Beth, dressed above her 14 years, asserts her seniority. She has been at Project Place longer, she should be first. But already Lenny is leading the way upstairs.

The 8x12 foot rectangle is euphemistically called a conference room. There is a table of sorts, etched deeply as a schooldesk. The only other furniture, a sofa, sags and puffs feathers as Lenny plops down on it.

He weighs no more than 90 pounds, he is not yet five feet tall nor 15-years old. He has skipped between 15 different foster homes.

"My father's an alcoholic," Lenny announces, discovering a piece of paper wadded in the sofa cushions. He shreds the paper on the floor.

"My mother couldn't take care of all five of my brothers, so they came and took us away. You go to a foster family with a social worker, and they're all goodie-goodie—next day it's a different story.

"I got along most places. But if you were a little kid and somebody like me moved into your house, how would you like it? It's a fight for attention. I'd just like to find someplace where there is a good father and mother and kids who aren't jealous of me. Sometimes I'm jealous of the natural kids, but I don't show it in any way."

He has stayed in one place long enough. He's up and bouncing like a sprite, with a cheshire-cat grin full of engaging devilment.

"One time I called up the police station and told them I was a runaway and disturbing the peace and to come and get me.

"It's all right here," he judges Project Place as he looks out the second floor window. "I tell the other kids I drink and take drugs, but I don't really. It's

not good for your body. I want to be a weight-lifter someday.

"I guess I'll give foster homes one more try," he says, dropping to the floor to do 12 one-handed pushups, just as he had claimed.

"I don't care what happens to me," he says, regaining his breath. "Of course I do *care*," he hangs on the word, "but not as much as I should."

A runaway shelter such as Project Place supplies all the care and guidance a youngsters will accept. The first night and meal are "free," no strings attached. If the runaway wants to stay longer, then he must agree to: call his parents or guardians within the 72-hour legal time limit; attend school; complete daily chores; participate in a bowling night or similar outing; refrain from drinking, taking drugs or stealing; and meet daily with an assigned counselor.

"This is not summer camp," emphasizes Marian Devance, one of the dozen paid Project Place counselors. "We have two weeks to help the kids—that's the program time-limit. There are a lot of runaways who need us, so we must have the turnover."

Shelter counselors try to identify the root causes of flight. But the runaway isn't to be trusted to present the complete picture.

"It's important to contact the parents to get the other side," says Devance. "We call together so the parents can't intimidate the child. Usually they just want to know 'Why?'"

Beth knows her reason 'why.'

"The sports were really hard, running five or six miles a day, too much discipline. And the academics *weren't* that good."

So she and a friend ducked out of a private school in Maine one night. She stayed the two-week limit at Project Place, talked again and again with counselors and her parents, but got absolutely nowhere.

"There's a contract parents must sign with the school," Beth explains with an incredulity to her voice that words on paper could mean so much. "It says that if their kid runs away from the school, the parents won't let them home."

No amount of professional persuasion could change the two adamant viewpoints, so parents and child remain unreconciled.

"I lived with my grandmother awhile, and my uncle. I'd like to go to a foster home, but my parents won't give me permission."

Beth is cultured and well-mannered, as runaways go, upper class and intelligent. Project Place is not so much a need for her as a want, and she still stops there most afternoons.

(Continued on page 32)

A small Tampa Cigar Manufacturer would like to demonstrate to a few Havana Lovers that you can still enjoy the unique Havana Flavor without Mr. Castro's permission.



My Offer to Cigar Lovers

I will send you postpaid a variety of 60 Factory Fresh Cigars. Smoke one or a half dozen with our compliments. If these cigars aren't all you expect and a great deal more, return the remainder by Parcel Post and I'll refund your money. No questions asked. Your delivered cost is only \$9.90 for 60 Factory Fresh Cuban Seed Leaf Cigars.

If you remember savoring and lingering over a fantastically mild and flavorful Cuban leaf cigar in the days before the Cuban embargo, you will be interested in this offer — and the story behind it!

When the Cuban embargo hit, we and other small manufacturers of fine custom-made cigars faced ruin. Our very existence depended on maintaining the same incomparable quality we had made our reputation on.





The solution was pure cloak-and-dagger. One dark night a few years ago a group of daring Cuban expatriates put to sea carrying a precious cargo of Cuban tobacco seeds. After running a gauntlet of Cuban gunboats they finally reached their destination — Honduras. Here under almost identical conditions of climate and soil, this prime tobacco flourishes to this day, far from its native land. This is the tobacco we use to make our superbly mild and flavorful cigars — cigars an expert can't tell from Havana.

To order: Fill in & mail coupon to: A194

THOMPSON CIGAR CO.
Dept. A194, 200 No. Edison Ave.
P.O. Box 1839, Tampa, FL 33601

O.K., TOM! Ship me the Thompson Sampler under your money-back guarantee for only \$9.90.

Check for \$9.90 enclosed. (Fla. residents add 4% sales tax.)

Charge \$9.90 to my    

BankAmericard

Master Charge

Diners Club

American Express

Credit Card No. (Print All Digits) _____

Master Charge Also Enter 4 Digits Below Your Acct. No. _____ EXP. DATE _____

name _____

address _____

city _____ state _____ zip _____

New Computerized Digital QUARTZ LCD

ANY LIGHT SOURCE

SOLAR POWERED WATCH

No button to push to get the exact time.

CONTINUOUS TIME READOUT IS CLEARLY VISIBLE DAY OR NIGHT

- No winding, no moving parts
- Normal day-to-day exposure to natural or artificial light is all it needs
- Stores its power — runs continuously *even in total darkness*
- Phenomenal quartz-crystal accuracy — within 5 seconds per month
- Solid-state integrated circuitry packs power of over 1000 transistors
- Gleaming gold-tone case and fully adjustable band

POWERED BY THE SUN OR INDOOR LIGHT

Normal wear keeps it charged day and night



SPACE AGE SOLAR PANEL
Same type used in U.S. communications satellites. Converts ordinary light to fail-safe electric power with normal wear.



Elegant gold tone finish matching band

THE WORLD'S MOST ADVANCED SOLAR ELECTRONIC TIMEKEEPING SYSTEM

As you might expect, the pioneers of electronic timekeeping now bring you another startling innovation — the Solar Watch. Finally... you can harness the power of the sun (or any other light) to the incredible accuracy of crystalline quartz. Add the convenience of continuous no-button time display, plus the ultra-slim styling of fine jewelry, and you've got the most advanced personal timekeeping system in the world. Maybe someday all watches will be like this. But why wait? The Solar Watch is here *today!*

Powered by Ordinary Light Waves
Bright sun or dim candlelight — solar panel stores energy for continuous operation.

6 Functions:
Hour, minute, running seconds, month, date, dial light. Change at a touch of the module command switch.

SAVE \$20.00! **\$59⁹⁵**
with the special savings certificate on page 22 you pay only

\$39⁹⁵ ATTRACTIVELY GIFT BOXED

YOU MAY PHONE YOUR CREDIT CARD ORDER
(312) 372-3368

Our references: American National Bank & Trust Co., Chicago, Toronto Dominion Bank, Toronto, Canada.

ELECTRONICS INTERNATIONAL A division of Robert Kahn Enterprises, Inc. CHICAGO ILLINOIS 60606

15 DAY FREE TRIAL PLUS MONEY-BACK GUARANTEE

Put your solar powered watch to the test for 15 days. If not completely satisfied, return for full refund.

<p>ELECTRONICS INTERNATIONAL Dept. WY-1 210 SOUTH DESPLAINES STREET, CHICAGO, ILLINOIS 60606</p> <p><input type="checkbox"/> I am enclosing my special \$20 Saving Certificate. Please rush ___ Solar Powered Watches at \$39.95 plus \$2.00 postage & insurance each. Specify ___ Men's; ___ Ladies.</p> <p><input type="checkbox"/> I do not have a certificate. Send ___ men's and ___ ladies watches at \$59.95 each. Ill residents only, please add 5% sales tax.</p> <p><input type="checkbox"/> I am enclosing \$ _____ <input type="checkbox"/> Send C. O. D. I enclose \$2 deposit</p> <p>Name _____</p> <p>Address _____</p> <p>City _____ State _____ Zip _____</p>		<p>YOU MAY CHARGE YOUR PURCHASE</p> <p><input type="checkbox"/> Master Charge Acct. No. _____</p> <p>Interbank No. _____ (find above name)</p> <p><input type="checkbox"/> BankAmericard (VISA) Acct. No. _____</p> <p><input type="checkbox"/> American Express Acct. No. _____</p> <p>Credit Card good thru _____</p> <p>Signature _____</p>
---	--	---

Bike Racing Makes A Comeback

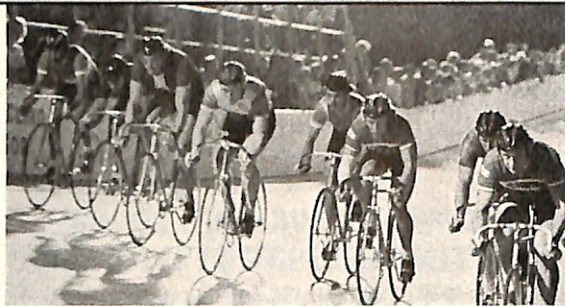
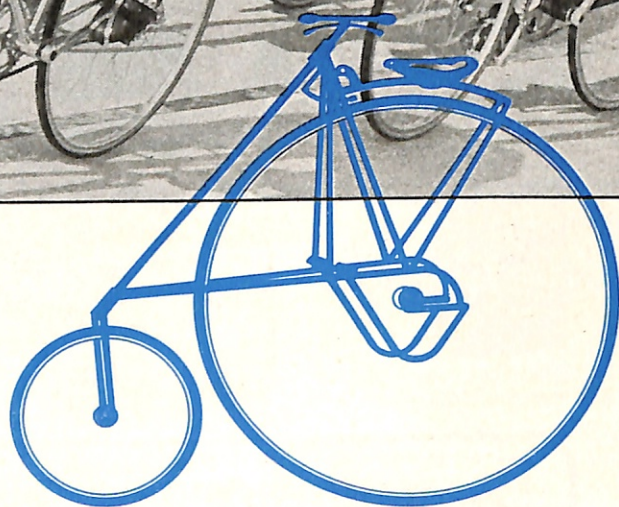
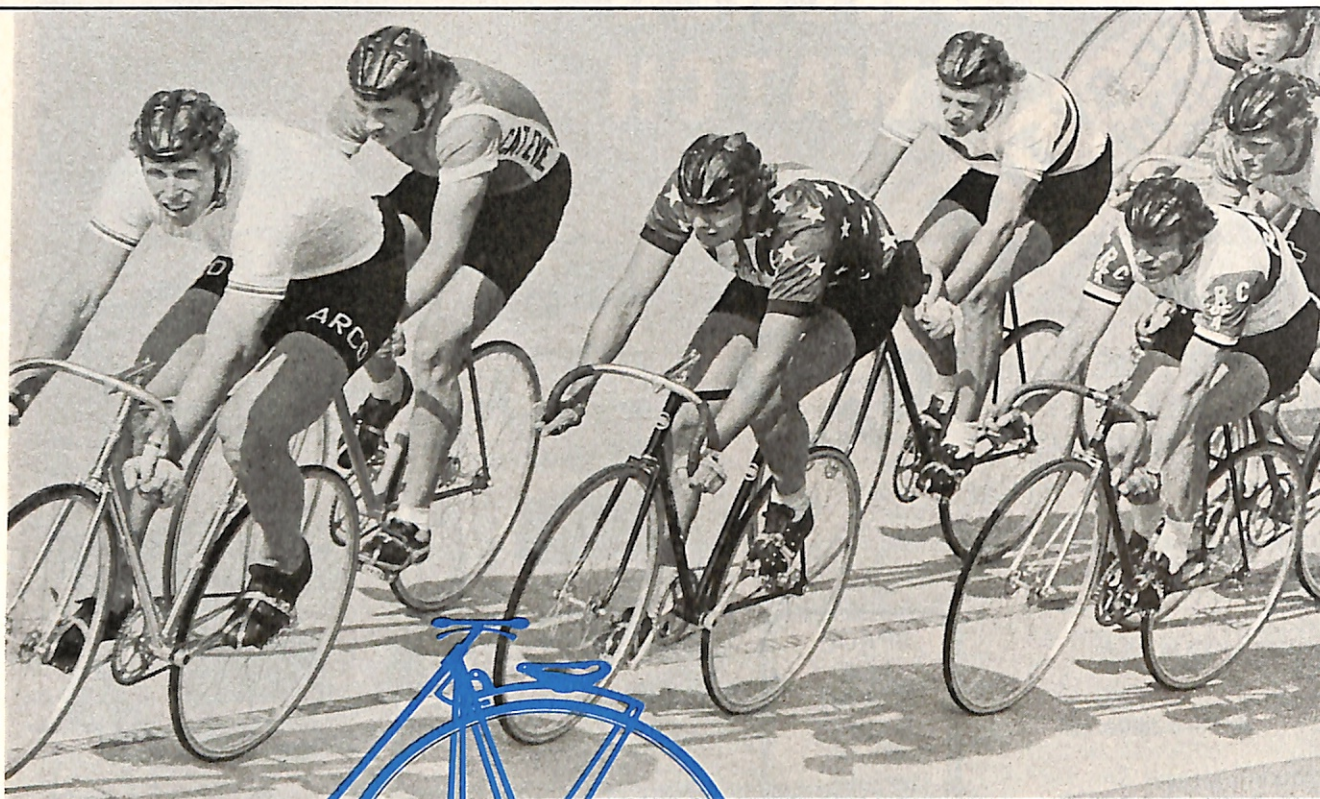

Willie Debosscher, the Belgian Bomber, tore into the banked curve at 35 miles an hour, and a thousand spectators were on their feet screaming his name. The Bomber, about to go for the lead, nosed his bicycle between the second- and third-place riders. Then someone swerved.

It was only an inch, but the bikes collided, sending twisted metal screeching against the cement track. Riders bounced like ping pong balls down the embankment, and Willie Debosscher lay stunned and bleeding on the infield.

"Boy, this is great," a teenager yelled. "Better'n TV, even!"

That's typical Friday night excitement at Trexlertown, Pennsylvania, where in 1976 a shy millionaire who never entered a professional bike race in his life built what was then the finest velodrome (bike racing track) in America—and the only one comparable in quality to the tracks of Europe. It opened with seating for 400, but by the end of the season as many as 5000 persons were crowding elbow to elbow around the track every weekend, filling the bleachers and standing in the infield.

"That kind of thing just ain't supposed to happen any more," says one oldtimer who regularly attends the Trexler-

town races. "They been telling us for years how bicycle racing's gone the way of the horse and buggy."

In its heyday at the turn of the century bike races drew regular crowds of 20,000 and more, while baseball was lucky to get 2500. For special races, schools, stores and banks were closed—the entire town declared a holiday. Some athletes, with a flair for the sensational, challenged thoroughbred race horses, while others competed against trains. In those days, crowds gathered regularly at more than 100 velodromes in the U.S.

Throughout Europe and other parts of the world, bike racing never lost its popularity. In fact, the best-loved athlete in the world, according to international polls, isn't Joe Namath or Muhammad Ali, but Belgian bike racer Eddy Merckx, a name that means nothing to all but a handful of Americans. That's particularly ironic, since Merckx is not only popular but rich—his winnings amount to almost a million dollars a year. He's been world cycling champ three years in a row.

In fact, bicycle racing fans throughout the world support about 5000 professional competitors—more by far than in any other sport. Yet, bike racing fever peaked in the 1920s



by Robert Bahr

in this country and has been on a downhill slide ever since. In the 1950s only two velodromes remained, and they were used by neighborhood kids for local competitions.

The oldtimers say bike racing was killed off by the advent of the automobile. Auto races were faster, noisier, bloodier—and the promoters knew they could capitalize on those sensational qualities to fill the bleachers and their purses. So they abandoned manpower for horsepower, and as the old velodromes deteriorated, mammoth auto race tracks replaced them.

Professional bike racing was dead and gone in America. Even in amateur competition we failed miserably. Not since 1904 have we captured an Olympics medal.

But the graveyard is stirring. Bicycle racing is making a comeback. From California to New England, in numbers unmatched in 40 years, people are paying good money to watch bicycle races. And the major catalyst has been the velodrome at Trexlertown, PA, and the shy millionaire who built it.

Passing Bob Rodale on the street, you'd take him for a 50-year-old slightly malnourished Grizzly Adams. In fact, he's the editor and publisher of *Prevention* magazine and

Organic Gardening and Farming, swears by wheat germ and thinks feeding your children sugar is the next worst sin to committing murder. Bob Rodale is also a champion skeet shooter (which he attributes in part to drinking lots of carrot juice).

At the Pan Am games in Winnipeg in 1967, where he competed in the skeet shooting events, Rodale saw a velodrome for the first time, and the sight astounded him. With bicycles only inches apart, a dozen gutsy racers shot into high-banked curves at almost 50 miles an hour, cut each other off, spilled into a heap of twisted metal and broken bones. This was no ordinary sport, Rodale decided. It took all the death-defying courage of the Indy 500, the endurance of a marathon runner, the coordination and balance of a pole vaulter, and enormous physical strength. The spectators loved it—they screamed themselves hoarse.

He returned home to Allentown, Pennsylvania, determined to persuade local businessmen to buy land and build a velodrome. Some of those he approached laughed openly, others politely declined. So Rodale tackled the project himself.

He and his wife owned 32 acres in Trexlertown, near the



junction of routes 309, 100 and 22, an hour and a half from Philadelphia or Harrisburg, two hours from New York City. Rodale decided to build the velodrome there. He cut no corners, avoided no expense.

Jack Nicholson, world professional bicycle champion in 1975 and 1976, visited the track, a 333-meter oval banked so that the outside lane is about 15 feet higher than the inside along the straightaway, and said it was "absolutely spectacular for speed and smoothness." He considers it one of the best in the world.

Building an excellent facility was only the start. Rodale himself began traveling the professional bike racing circuit looking for talent. He found it in Jack Simes, who had raced in three Olympics, competed as a professional in Europe and won a silver medal in the 1968 world championships. Simes' *Winning Bicycle Racing*, is the only widely available book on the subject in America. Simes was the coach for the 1976 U.S. Olympic Bicycle Team. Rodale made Simes an offer he couldn't refuse, and Jack signed on as velodrome director.

He brought with him Dave Chauner, a veteran international racer who had

competed in two Olympics. Dave became programs coordinator and race announcer. Thus, the Trexlertown International Velodrome was not only the finest in the country, but the only one with two full-time professionals.

Their first big challenge: to bring to Trexlertown some of the world's best-known competitors. It wasn't always easy. European athletes in particular aren't eager to race in America, where the purses are low and the sport considered second-rate. But Simes and Chauner convinced many big names that, with their help, bike racing could actually nudge its way into the holy trinity of sports—baseball, basketball, and football. And if that ever happened, there could conceivably be more glamour and money in American bike racing than in any other country in the world.

Then Simes pulled off a brilliant and daring gamble. Early in July, 1976, he went to the Olympic races in Montreal, persuaded the world's top racers from Turkey, Australia, Chile, Czechoslovakia, Great Britain and Trinidad to stay in North America a few days longer, rented a bus on the spot and took the team on an 11-hour jaunt to Trexlertown. Simes called the resulting two-day event the First North American International Championships. Never had there been such an array of cycling competitors in the U.S.

Simes and Chauner used personal friendships, Rodale's money and imaginative promotion to make the velodrome work, and suddenly a sport that rarely drew more than 200 spectators anywhere in the country was pulling overflow crowds.

"But to keep them coming week after week you need *enthusiasm*," says Chauner. And he has it.

"Look at Bruce Donaghy go!" he screamed into the microphone one day last summer. Donaghy, an 18-year old from nearby Philadelphia, had just passed one of Europe's best-known sprint racers and was heading for the wire. A moment later Dave Chauner shut off the microphone gagging.

"Almost did it again," he muttered, shaking his head. Last year he'd gotten so excited announcing a race that he injured his larynx and had to be hospitalized. "I just get too darn excited," he said, recovering. "Even before anything's going on, when the people are coming in and these guys are getting their bikes ready, I feel that old adrenalin start to surge again. And then, in the race, I guess I just start identifying. When the champ is in the lead, I'm the champ and I'm rooting for him. And then some dark horse no one ever heard of sneaks out of the pack and

(Continued on page 28)

Drill Your Own Water Well 50...100...200 Feet Deep.

SAVE HUNDREDS OF DOLLARS!

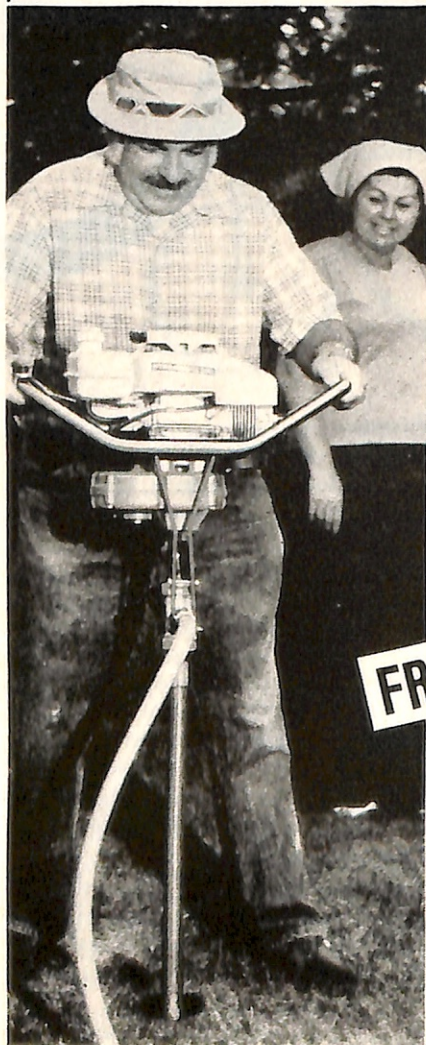

You can tap the vast supply of good, clean, pure water beneath the surface of your property and have all the water you need!

Invented over 15 years ago, the *Hydra-Drill* has been used by thousands of people all over the world to drill water wells for home and garden. It can also be used to drill horizontally into hillsides to form free-flowing springs. Amazingly it is almost as easy and inexpensive to operate as a power lawn mower.

If you want to know more about this wonderful way to drill your own water well and have a lifetime supply of water for just pennies per day, then do yourself a favor. Write or call for FREE fully-illustrated information including the booklet *HOW TO DRILL YOUR OWN WELL*. The information package will be rushed to you by return First Class mail.

Deeprook Mfg. Co., Opelika, Alabama 36801

Phone Toll-Free

(800) 821-7700

— OR — (Ext. 522Y)

CLIP COUPON AND MAIL TODAY!

FREE

Deeprook Mfg. Co. Dept. E78
Opelika, Alabama 36801

Please mail your free information kit immediately. I understand there is no obligation.

Print Name _____

Address _____

City _____

State _____

Zip _____

© 1978, Deeprook Mfg. Co.

IT'S YOUR BUSINESS

by John C. Behrens

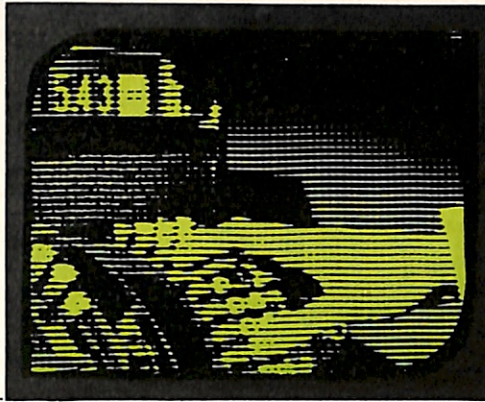

STARTING A NEW BUSINESS

The ads in any number of publications are persuasive. They tell you how you can start a new hobby and "double your present income;" build your own \$100,000 bank account with a no-risk guarantee and make money selling things to the Arabs.

A former student of mine, Paul Montana, his father and family decided a few years ago that there must be a market for people who wanted to know how to find a toll-free telephone number. Today, the Montana publishing enterprise, called the "Toll-Free Digest," is found on newsstands throughout the country. It provides a telephone user with a service that isn't available nationally.

But for every successful idea that has launched a business, there's another that fails. As a result, for the thousands who succeed each year an equal number quit or go into bankruptcy. The reasons, says James W. Lundy, manager of the Penn State University's Small Industries Research program, may simply be that the would-be entrepreneur gambled on success without a realistic assessment of two prerequisites for any business today: planning and management.

"Too many people plunge in without having investigated what type of business might best succeed, where to put it, how to outdo competitors, how much working capital they'll need and for how long before they turn a profit and all the crucial financial details," Lundy explains.

The fact, though, is that more and more Americans as they reach retirement age, face layoffs or simply get bored doing what they do everyday, dream of a chance to start something of their own. It could be a small engine repair shop, a newsstand, a restaurant or a myriad of other service or sales opportunities. The reasons are usually the same. "I just want a piece of my own rock for myself and my family," said a friend of mine.

Lundy thinks that before you make such a decision, however, you should put the arguments for and against on paper and weigh the results carefully.

"It seems to be a rule of thumb that, much like a marriage, if you can last out the first seven years then you probably are going to make it," he warns those who talk about next month as if it was long-range planning. "The problem is too many people plunge into a retail business

without having done their homework.

What's the best way to raise your chances of success? "Choose something novel or new," he replies. "Be a leader before everyone gets into the act. An example is roller skating, which is currently catching on in California. People are opening rinks and seem to be making money at it. A couple of years ago it was bicycles. The people who got in early made money . . . it's always that way."

But there is still the question of sacrifices regardless of how much of a demand there is for the service or product. "A big issue is the amount of time you would have to put in. Chances are you'd be working more than a 40-hour week. Another sacrifice may be financial. For a long time, or perhaps forever, you may be

earning a lot less than you were accustomed to. Even if your earnings go up, is the extra income and effort that will most likely be necessary worth the extra income?" he adds.

"How you truthfully answer these questions can make all the differences between a business that succeeds and one that doesn't. Some people don't care enough to really work at a business. To them it's just another job. Get up each morning, go to work, run your business, go home and forget about it. But the people who are really successful don't go home and forget about it. They are always working for tomorrow. They are watching the business, changing things, trying new things."

Lundy thinks too many new business owners simply don't ask the right questions of prospective employees. "They don't look at the intangibles that are difficult to evaluate. The employer who will hire the right people has a feel for people. He will look for maturity, motivation, the ability to deal with people and situations. References are a big help, particularly former employers, no matter what kind of job the individual did.

What type of individuals starting in business are likely to make good managers and owners?

"It doesn't have much to do with education, at least formal education," Lundy explains. "I think good management is essentially a question of philosophy. It has more to do with all your values, with how you approach life really." ■

Available now for a limited time only... THE TREASURY COLLECTION OF SIX OBSOLETE COINS

Includes a rare silver dollar minted almost 100 years ago.

A sound investment. This prized collection of six obsolete U.S. coins includes the rare Morgan silver dollar, the Walking Liberty half dollar, Standing Liberty quarter, Mercury dime, Liberty nickel and the Indian Head penny.

Each collection is mounted on a royal blue background in a handsome presentation case. Makes a treasured gift to hand down from generation to generation. Ideal for Holiday giving.

Our supply is limited as most of these coins are almost unobtainable. Order now as this may be your last opportunity to purchase this rare collection. Money back if not completely satisfied.



FOR CREDIT CARD ORDERS
CALL TOLL FREE: **800-331-1000**
(Oklahoma Residents Call 918-664-8300)

We are members of the Retail Coin Dealers Association
for 15 years—in business for over 25 years.

Novel Numismatics Guild, Inc., Dept. EK-301
31 Second Avenue, New York, N.Y. 10003

Please send me the coin set(s) checked below.
Enclosed is my check, Money Order..... for
\$.....as payment in full. (New York residents
please add sales tax)

- 1 Coin Set for \$29.95 plus \$1.00 p.p., handl., ins.
 2 Coin Sets for \$55.50 plus \$1.50 p.p., handl., ins.
Save \$5.00
 4 Coin Sets for \$100.00 plus \$2.00 p.p., handl.,
ins. Save \$20.00

Name

Address

City State Zip

Charge my BankAmericard Master Charge
 Visa American Express

Master Chg. Inter Bank No. Exp. Date

Credit Cd. No.

Signature

MAJOR PROJECTS

This is part of a continuing series on the state major projects. All state chairmen have been contacted by The Elks Magazine and have been asked to forward information for upcoming articles.

At the Medical Center of Indiana University School of Medicine, a doctor and his colleagues explore the details of interaction of individual molecules at the level of the cell membrane. In the laboratories of Purdue University, professors and doctors from departments, such as that of Bionucleonics, study the effect of microwave and ionizing radiation treatment regimes upon tumor growth and metastasis rates. What do these research programs have to do with Elks? The **Indiana Elks Association, Inc.**, helps fund cancer research which is supported by two Indiana universities. The Brothers' major project is a year-long, intensive fund-raising program, the entire proceeds of which go towards cancer research and fellowships.

One year's contribution of \$50,000

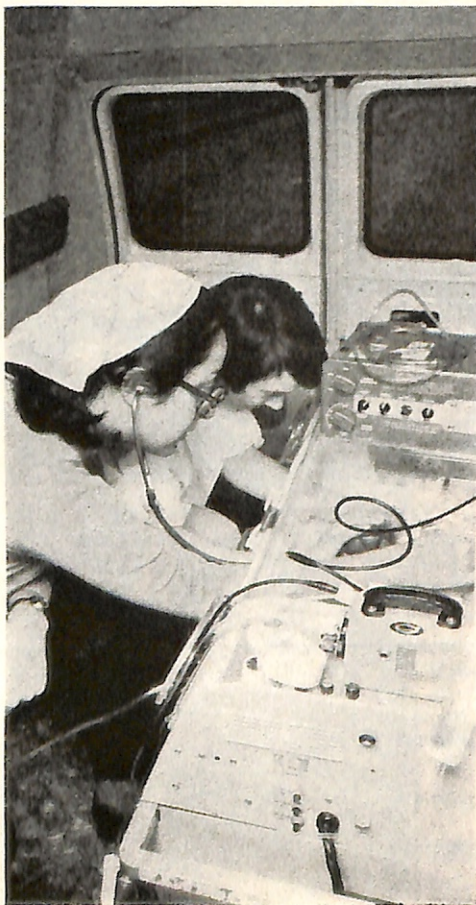

The neonatal ambulance

helped support four scientists active in cancer-related research at the Indiana University School of Medicine, and a \$35,000 donation to Purdue University enabled that school to award approximately 10 one-year grants to faculty members who are carrying on research to advance the fundamental knowledge needed to cure cancer. In the 31 years of its existence, the major project has distributed a total of \$1,784,850 to the universities. All of the funds are used within the state, and none have been spent on administrative costs. Any outside expenses incurred have been assumed by the state association.

The Indiana Elks Cancer Fund was inaugurated by the late Dr. A. A. Pielemeier



Indiana Elk Thomas Burke (left) presented \$50,000 for cancer research to Dr. Beering of IU.

in 1947 on his election to the presidency of the state association. Dr. Pielemeier and the late PSP Harry McClain served as co-chairmen of the project until 1952, when they were succeeded by the present chairman. The methods of fund-raising are the responsibility of the state's 74 lodges and often take the form of memorials from the families, relatives, and friends of deceased Elks. Included in the monetary donations are funds for the purchase of equipment, such as two electron microscopes obtained by Indiana University Medical Center. The promotion of advertising programs for cancer control also receives support from the major project.

The knowledge that they are aiding their local academic and medical communities is one of the rewards the In-

diana Elks receive for their hard work and generous gestures. But the greatest compensation for them is the hope that there will be universal benefits from the programs they aid. By helping to buy costly equipment and chemicals for research, the Brothers are nurturing the humanitarian spirit which will make that research of value to mankind.

In the early 1970s, the Elks of Indiana put their fund-raising talents behind another medical project in the state. Babies from the state's small communities and rural areas whose chances of survival were based solely on reaching a newborn intensive care center had no swift and medically-equipped means of transport. The need was for an ambulance which would be as well-equipped as any hospital's newborn center—and for the funds which could purchase and furnish this "hospital on wheels."

A doctor at James Whitcomb Riley Hospital for Children at Indianapolis, IN, designed a transport system which would cover a radius of 75 miles and serve 45 hospitals. Two Elks who were also members of the Riley Memorial Association heard of the doctor's ideas for an innovative ambulance and brought the plans before a meeting of the Indiana Elks. The Brothers agreed to consider supporting the vehicle and asked that a formal vote be taken at the next state convention.

The hospital went ahead and ordered the equipment—heart and breathing monitors, respirators, blood transfusion units, oxygen, and diagnostic equipment. The ambulance was ready in time to go to the Elks' convention, where the vote in favor of subsidizing the vehicle was unanimous. \$50,000 passed from the Indiana Elks to the Hospital, which promptly added a sign, "Gift of the Elks Lodges of Indiana," to the side of the yellow and orange ambulance.

Over 1,000 babies have ridden in the vehicle since its introduction to the highways of Indiana. The children who travel to the newborn center are often premature and suffer respiratory distress, which can be caused by various diseases. The number of children who survive, due to the greater accessibility of the hospital facilities, has risen over the past few years. Once again, the Indiana Elks proved that they were in the right place at the right time with their support.

Nestled in the woods on the south shore of Pelican Lake, the **Minnesota State Elks Youth Camp** is a place where a summer's activities become a variety of enriching experiences for children. The camp is approximately 3½ hours by car from St. Paul or Minneapolis and only 12 miles from Brainerd. From June 15 through September 1, the camp is full of children from 9 to 12 years of age who spend a term of two weeks on the wooded 250 acres.

An L-shaped dock is the welcoming spot to the camp for water traveling visitors. Once one disembarks, the boats along the sandy beach and the totem pole marking the 'council ring' introduce

(Continued on page 30)

NEWS OF THE LODGES

The annual Wild Game Dinner was held at **Belvidere, IL, Lodge** recently. The menu included a variety of foods, ranging from wild duck to elk and venison, most of which was contributed by hunters. \$3,600 was raised by the event and was contributed to the Youth Activities fund.

Peacock bass were caught during a fishing expedition taken by GER Homer Huhn, Jr. (left) and PGER William Wall (second from right) when they visited **Cristobal, CZ, Lodge**. (From left) Est. Lect. Kt. Wilfred Holt, DDGER Darwin Pope, Secy. Kenneth Willis, and ER Robert Waggoner of the host lodge introduced the visitors to Gatun Lake.

The Red Cross of **Rockland, ME**, received a lifesaving demonstration mannequin from the local lodge recently. On hand for the presentation of the gift were (from left) Treas. Lyndon Nelson, Jeff Small, CPR instructor, ER James Flanagan, PER and Trustee Joseph Soffayer, and Ken Black, Red Cross chairman.

Representatives from the Elks, Lions, National Alliance of Businessmen, YWCA, and Girls Clubs of America attended a conference in **California** on drug abuse recently. The theme of the project, entitled **Catalyst**, was "Expanding Organizations' Involvement Through Primary Prevention," and it emphasized

Learning life-saving techniques in Rockland, ME



promotion of alternatives to drug abuse as a way for youths to cope with problems. Brothers Norman Lien, Past GL Youth Activities chairman, Vern Forry, California Youth chairman, SDGERs Philip West and Robert Tancredi, Esq. Lowell Tarbell, and Phil Coffin attended the California Catalyst conference.

A check for \$225 was donated by **Marysville, OH, Lodge** to the Marysville High School debate team. The contribution paid for four days of room and meals during the team's stay in Williamsburg, VA, where the national debate contest was held.

The Brothers of **Virginia City, MT, Lodge** welcomed John Jordan, coordinator of the Vets leather program, to their lodge recently. Chm. Jordan thanked the Brothers for their many hide donations, and commended them for being awarded the Byron Robb traveling plaque for contributing more hides than any other lodge in the state.

An honorary dinner was held by **Cortland, NY, Lodge** for the Cortland State University soccer team. Both the team and its coach received recognition for their performances in the NCAA.



The fisherman at Gatun Lake

During the Silver Anniversary celebration of **Victorville, CA, Lodge** three National Foundation members were honored. Brothers Fred Weberg, Lewis Ballinger, and Charles Boynton all became honorary founders.

Twenty new members, their wives, and their sponsors were honored by **Westwood, NJ, Lodge** during the seventh annual New Members Night. The Westwood Brothers also paid tribute to Treasurer and PER Jack Jensen, PER Bert Atherton, and Past Trustee James Fraser, who all received National Foundation pins and certificates for the fulfillment of their \$100 pledges. Four out of the five district "Hoop Shoot" winners were sponsored by Westwood Elks, who congratulated champions Brian O'Connor, Cathy and Brian Mulligan, and Donna Sardanopoli.

A donation of \$150 was made by **Fort Lauderdale, FL, Lodge** to the Miami VA Hospital for the purchase of books. Mr. Robertson, director of volunteer services, thanked Chm. C. B. Walls, who presented the check on behalf of the lodge.

Joining **Paw Paw, MI, Lodge** for the initiation of 30 new members were the Brothers of **Sturgis, MI, Lodge**. Seven deputies of VanBuren County, sponsored by Sheriff Richard Stump, were among those introduced to the order. During the past year Paw Paw Lodge has welcomed over 100 new Brothers to Elkdom.

When the Brothers of **Anaconda, MT, Lodge** moved to their new lodge some years ago, the old one was bought by the local Knights of Columbus. Four chandeliers with bronze elk heads holding globes, installed over 64 years ago, were left in the building. The Knights of Columbus recently announced that they are considering bids for the unique lamps.



FARGO, North Dakota, Elks recently contributed \$500 to the Shanley High School Chorus for their trip to Washington, DC, where they performed at the Cherry Blossom Festival. Steve Gorman (front row, second from right), trustees chairman, presented the check to Brother Michael Collins (front row, second from left), school superintendent, while four senior members of the school's singing group, "The Sand Pebbles," gathered to express their appreciation.



AN ELEVEN O'CLOCK Toast contest was held for the first time in the Southeast District of Florida. The event was organized by PER Jack Decker (left), district ritualistic chairman, and held at Jupiter Lodge. Grand Trustee H. Foster Sears (right) joined Brother Decker in congratulating the winner, PDD Eugene Boggs of Delray Beach Lodge.



THE PROCEEDS from the fourth annual golf tournament run by Milford, CT, Lodge were donated to the Newington Children's Hospital. PER Douglas Murray (left), Chm. Vin Kostzewski (third from left), and ER John Dunn (right) presented the \$500 check and a new wheelchair to A. John Menichetti, executive director of the hospital.



WIELDING a shovel, ER Stanley Sullivan (center) opened the groundbreaking ceremonies for Livermore-Pleasanton, CA, Lodge's building expansion project. The new building, estimated at a cost of over \$120,000, will double the size of the Brothers' present facilities. Also on hand for the occasion were (front row, from left) Ned Brooks, Bill Gazda, Charles Anderson, and PER Lyle Helstrom.



THE DIAMOND anniversary of Provo, UT, Lodge was commemorated by the Brothers with a gala open house. During the festivities (from left) Darrell Berkheimer, Royce Ridge, ER Dean Rowland, Trustee Charles Clark, PER Neal Kershner, and PER Karl George gathered around the cake to sing happy 75th birthday to Provo Lodge.



THE WINNERS of Michigan's Southwest District ritualistic contest (from left) Coach Tom Ruble, Tiler Reggie Chorpensing, Est. Lect. Kt. Brenn Arklie, Chap. Richard Holtz, Est. Loyal Kt. Don Patten, ER Ed Schragg, In. Gd. Ken Heslop, Est. Lead. Kt.

Gene Adams, Esq. Jerry Baker, and DDGER H. Keith Waltke, coach, displayed the trophies for their Brothers of Sturgis, MI, Lodge. It was the second year in a row that the Sturgis team returned as the district champion.



A FOUNTAIN for the vestibule of the new Veterans Administration building in Scottsbluff, NE, was the gift of the local lodge. Present to view the structure recently were Governor J. James Exon (third from left), Everett Phillips (fourth), director of Nebraska Veterans Homes, Fonda Brown (fifth), county vets service officer, and Bob Brozek (sixth), administrator of West Nebraska Veterans Home. Scottsbluff Lodge representatives Bob Taylor (left), vets chairman, and ER Cork Brown were on hand to greet the dignitaries and to accept the thanks offered by the Veterans Administration for their generous gesture.



TEENAGERS of the Year (from left) Stacey Abel and Thomas Ajamie were honored by the Brothers of Phoenix, AZ, during an annual youth banquet held at the lodge. Chm. Bill Draves congratulated the youngsters and presented framed certificates and \$50 to each of them.



INITIATED recently at Platteville, WI, Lodge were Mike (left) and Larry Stephens (second from left) and their cousin Vaughn White (right). The young men were congratulated by their grandfather Donald Stephens (fourth from left) and their fathers VP Gordon Stephens (third) and ER William White. There are a total of eight Brothers from the Stephens and White families who belong to Platteville Lodge.



A BIRTHDAY cake was presented by the PERs of Mount Adams (White Salmon), WA, Lodge to their Brothers in honor of Elkdom's 110 years of existence. Among those on hand to salute their history of involvement with the order were (from left) PERs Monty Crews, Robert Warneke, William Logan, and George Mersereau, ER Jerry Davies, and PERs Don Warneke, Doyle VanDeventer, and Fred Purvis.

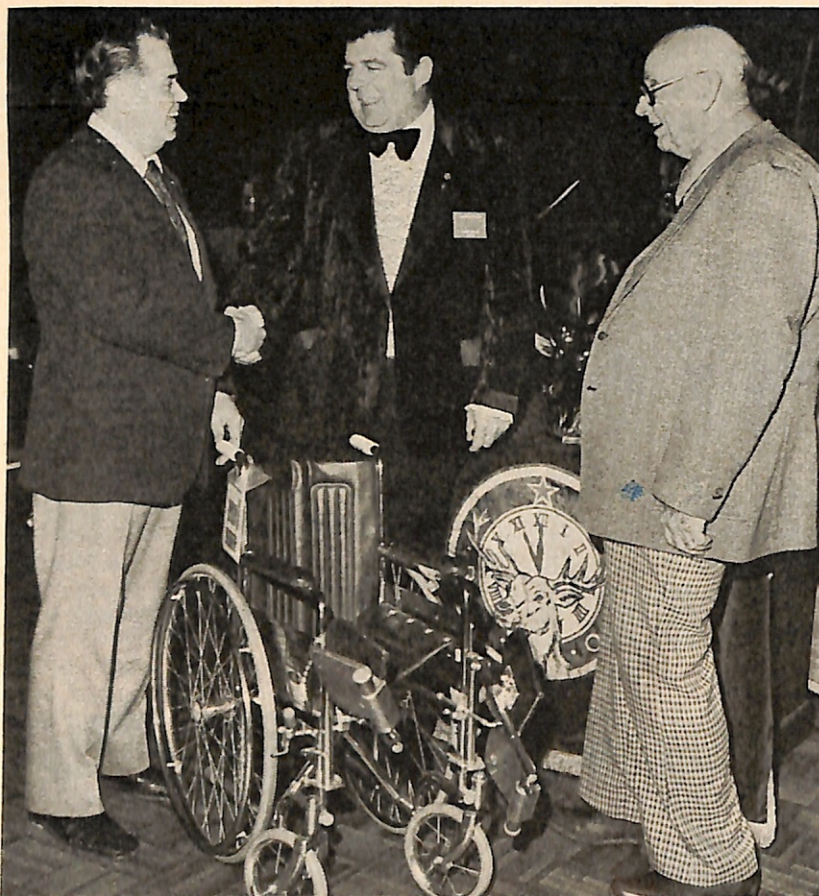

FOR THE SECOND time since he became a member of Westerly, CT, Lodge, Thomas Lombardo (second from right) received the Exalted Ruler's gavel. DDGER Angelo Lombardo passed the gavel to the ER, who is also his brother, while Thomas's daughter, Mrs. Ida Service, Elks' ladies president, and his son-in-law Esq. David Service observed.

A WHEELCHAIR was presented by Belmar, NJ, Lodge to the Crippled Children's Committee of three-year-old Manasquan, NJ, Lodge. ER Robert Callanan (left) of Belmar Lodge delivered the gift to Trustee Robert McCabe (center) and Health and Welfare Chm. Willard Nock of Manasquan Lodge in a "neighborly gesture."



A BLOOD DRIVE was sponsored by Pembroke-Hanover, MA, Elks at the lodge quarters recently. Brothers and local citizens who participated contributed a total of 49 pints of blood. The event was organized by Chm. Roger Grant.



OLD TIMERS Night at Los Angeles, CA, Lodge was attended by 110 Brothers who welcomed the Metropolitan District "Hoop Shoot" winners Lisa Anderson and Keith Hopkins. The two nine-year-old contenders were congratulated by "Hoop Shoot" Chm. John Sas and ER Armando Gomez on behalf of the lodge. Keith was also the regional winner and the state runner-up.

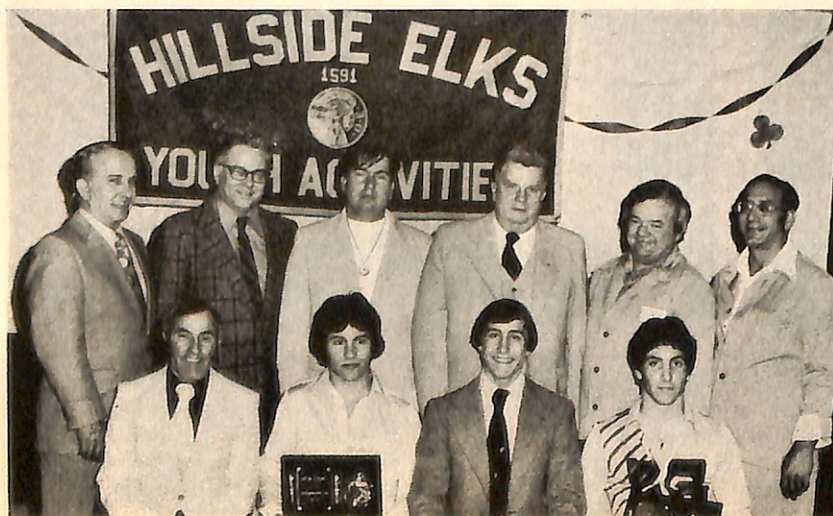

WRESTLERS from the Hillside High School wrestling team attended an annual dinner given in their honor by Hillside, NJ, Lodge. (Seated, from left) Coach Zappula and students John Young, Michael Kaufman of Millburn High School, and Frank Pais were on hand for award presentations made by (standing, from left) Brothers Al Lordi, Dave Pearce, Boyd Beattie, George McDonald, Charley Ritz, and Tony Naples.

(Continued on page 34)

by Jerry Hulse

ROMANTIC HIDEAWAYS



Each year the state of Hawaii grows ever more popular. New hotels rise along once-deserted beaches, tour buses roam country roads, and visitors in ever greater numbers pour onto the neighbor islands of Maui, Kauai, Molokai and the Big Island of Hawaii, settling at such well-known resort areas as Kaanapali, Wailea, Kona, Hilo and Poipu until it seems no place in the islands remains undiscovered. Still, there are little-known destinations: *the romantic hideaways of Hawaii.*

Beginning with a sentimental favorite, the list takes in small inns and resorts on all the islands, each exuding an individual charm and a particular reason for entering its name in the memory bank. This is especially true of Hotel Hana-Maui which rates a special rave, just as it always has. Low-rise and peaceful, Hana-Maui is a cluster of 55 single-story units set on 20 acres of this earth's loveliest terrain. A fellow writer once called it "one of the last outposts of 'The Great Unspoiled.'" Amen. Those who have been there will carry the memory with them forever. Although one is tempted to fly to this remote chunk of paradise, to do so would be a mistake; the drive is an inspiration. While the road is narrow—twisting constantly—it's worth every confounded bounce. Climbing above the sea between Kahului and Hana, this is a drive of which dreams are made. Rainbows fall from the heavens; golden waterfalls feed peaceful ponds, and they in turn mirror shower trees, blue skies and orchids.

I took this drive originally in a pink-striped Jeep, long before the road was paved. It was filled with ruts and near-dropoffs, hundreds of feet above the ocean. Never mind, though. What I saw made up for the small discomforts. Moss and vine-covered mountains rose into pure white clouds; occasionally rain fell and then the sun would shine again, creating still another rainbow. Well, eventually we made it to Hana and Hotel Hana-Maui which was everything we had been told it would be: a cluster of handsome cottages with shake roofs and a staff genuinely imbued with the notion of spreading the Aloha spirit. It is the haunting beauty of Hana's setting, though, which makes it special. Of Hana's Hamoa Beach, James Michener once wrote: "It is the only beach I have ever seen that looks like the South Pacific was in the North Pacific—a beach so perfectly formed that I wonder at its comparative obscurity."

Well, enough of Hana. On this same island there exists another resort worthy of mention, and it is Jack Millar's Napili Kai Beach Club. It is beyond

Romantic Hideaways

the old whaling village of Lahaina and storied Kaanapali Beach, down a country lane to a place where a rainbow sea washes against its shore. Like Hana, it, too, is low-rise and low-key and designed for relaxed Hawaiian living.

I have a neighbor who goes there twice a year. For her it's a drug, a habit that's impossible to kick. This place I speak of is surrounded by palms and plumeria and orchids of every imaginable color. Its reef-protected beach is one of the finest on any island in the world. Each morning guests gather there for coffee and to drink in the scene beyond. At day's end they turn to the House of the Maui Moon, sipping mai tais and watching the sun tumble quietly behind the island of Lanai.

Lanai is Hawaii's pineapple isle, bought in 1922 by the Dole people. It is a place for romantics seeking total escape. Because of this, few tourists bother to go there. On the entire island only one inn exists, the little 11-room Lanai Lodge, a ramshackle affair that's reminiscent of Mary Pritchard's old Rainmaker Inn in Pago Pago. Although a bit un-elegant—the rooms are plain and the beds sag—obviously it's a bargain, costing only \$17 a night single

and \$20 double. Besides this, it has the only bar on the island.

Jeeps may be rented for exploring the pineapple plantations, and down at Shipwreck Beach great ghostly vessels are awash, abandoned to the elements. Elsewhere beachcombers gather Japanese glass balls that wash ashore with the currents. On Lanai there are peaks to explore as well as pleasant bathing at Hualupe Beach. Died-in-the-wool romantics will recognize the island's charms.

For romance at its fullest I can think of few hideaways that can compare with Kona Village on the Big Island. Kona Village is Hawaii's wedding and honeymoon capital. Couples gather on the beach at sunset; the bride and groom march barefoot to the sea. By the time social director Kamanookaleo Okalani Beckley croons the "Hawaiian Wedding Song" there is not a dry eye in the entire village. Kona Village is the ideal setting for the marriage ritual—a miniature Polynesia with thatched huts containing king-size beds, sliding glass doors, refrigerators and hot showers.

Kona Village stands alone at the end of a great lava flow, surrounded by Keawe and Hau trees. The bougainvillea is a startling red and the ocean is the shade of laundered jeans. Remote and peaceful, Kona Village seems

separated by an eternity from the rest of the world. For couples with stars in their eyes there's a honeymoon package that includes wedding announcements, a cake, champagne, a picture album with photos of the ceremony, plus a four-day honeymoon in one of those thatched cottages.

On the same island, Don Hart's Keauhou Resort gets its share of raves—a cluster of one-, two- and three-level townhouses close by Keauhou-Kona Golf Course. Hart's colony features a couple of swimming pools, all-electric kitchens, washer-dryers, refrigerators, ice-makers and color television sets. Rates for a couple start at \$35-a-day, with a five-night minimum. Only one snag here: no beach. The address: Keauhou Resort Condominiums, 78-7039 Kam III Road, Kailua-Kona, Hawaii 96740.

And then there's Sheraton's new spread on the Friendly Isle of Molokai. Like Kona Village, it's both remote and peaceful. (If it's action you're after, scratch it from your list. Otherwise, this enclave of 34 one- and two-story Polynesian-style bungalows will do just nicely.) In all of Hawaii, few resorts offer this brand of escape. No cars, no high-rises, no night life, no radios, no TVs. Just the peaceful wash of the seas. Sprinkled across 29 acres, Sheraton
(Continued on page 28)



THE JOY OF GIVING

Elks National Foundation
2750 Lakeview Avenue • Chicago, Illinois 60614



The highlight of a Foundation dinner-dance held at Peekskill, NY, Lodge was the unveiling of a new honor roll board which contains over 600 names. (From left) Est. Loyal Kt. William Carroll, PDD and Chm. Greg Emery, ER Thomas Ryan Jr., Secy. H. Ellis Finch, and PER Louis Morris Jr. were among those responsible for the successful affair, the proceeds of which were \$500.

An honorary founder's certificate was presented to PDD Louis Rapier (left) recently by District Chm. H. Frank Oglesby (right). ER Wayne Malone, who along with Brother Rapier is a member of Kinston, NC, Lodge, was on hand to offer his congratulations.



PSP Jesse (right) and Alberta Edwards were among over 80 Elks and guests who attended Kimberling City, MO, Lodge's first annual National Foundation dinner. ER Scott Kennedy and Chm. Marsh Edinger reported that over \$800 was raised for the Foundation.



MEDICINE AND YOU

by Larry Holden

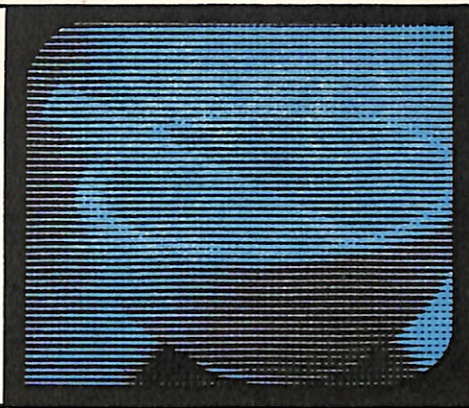

THE SAVAGE SUN

Sometimes too hot the eye of heaven shines.
Shakespeare

The sun will shine too hot for many Americans this summer. Some of us will even die from it.

Death from heatstroke—also known as sunstroke—is much more common than statistics show, explains Dr. James P. Knochel, a nationally-known expert on heat injuries.

"These deaths usually are ascribed to something other than heatstroke because heatstroke is preventable and acknowledgement of its occurrence is embarrassing," notes Dr. Knochel, professor of internal medicine at the University of Texas Southwestern Medical School at Dallas.

Heatstroke is almost always associated with extremely hot and humid weather. A number of conditions make an individual more susceptible to heatstroke, including heart disease, obesity, the use of certain drugs, and alcoholism and diabetes (both of which can result in dehydration and malnutrition). But summer's siege of blistering heat can have fatal or disabling results for joggers, tennis players or gardeners, if proper precautions aren't observed.

A lot of the heatstroke patients are obese people who are not accustomed to blazing summer heat. Some of them take diuretics (drugs which decrease body fluids) to lose weight, which really make it dangerous for them to work in the heat because their blood volume is inadequate.

"Heatstroke, if untreated, is fatal," says the noted physician. "Some respond to nothing more than simple cooling . . . it depends on how hot they have been and how long they have been that way."

There are basically two kinds of heatstroke, exertional and classic. In exertional heatstroke, heat is generated during muscle activity: work or exercise. The heat accumulates faster than the body can dissipate it. Classic heatstroke may occur with or without exertion. There is an inability of the circulatory system to respond to heat stress and not enough sweat is produced to cool the body.

The heart is the key to a person's ability to cope with the heat. It must increase its output in order to pump the hot blood to the skin surface where the heat is then dissipated by sweating. If for some reason the heart isn't able to respond

properly or the blood volume is low, then the sweat mechanism will not work as it should.

When someone has heatstroke, they are in a coma: that is, they are unresponsive to any external stimulation. Sweating usually ceases, so their skin is dry, extremely hot to touch, and flushed. In contrast, those suffering from a less serious heat illness, heat exhaustion, will be sweating and may still be conscious. They may become confused, even pass out, have a fever. Later they may experience muscle pain, headaches and nausea. Usually they feel weak and just need water and rest.

The body temperature of heatstroke victims usually exceeds 106 degrees. If their temperature reaches 108 degrees the heat starts altering proteins, which are what the whole body is made of. What happens is every tissue and organ—including the brain—literally gets cooked. At that temperature permanent brain damage is likely.

First aid for heatstroke victims concentrates on lowering the body temperature as quickly as possible. Your first inclination might be to call an ambulance, but the victim could die before the ambulance gets there. Instead, the first thing to do is get the victim out of the sun, remove his clothes and then douse him

with water. Use a piece of his clothing, or whatever is available, to fan him.

The goal is to imitate the sweat mechanism, Dr. Knochel explains. "If you lick the back of your hand and blow on it, your skin immediately will feel cooler. The sweat mechanism is based on the same principle: as sweat evaporates from the skin it cools the body. Using this technique as first aid, you might have the heatstroke victim half-cooled by the time the ambulance arrives."

During hot and humid weather ambulances and hospital emergency rooms should be stocked with plenty of ice. Ice massages and ice baths are used by trained personnel to further lower the body temperature of a heatstroke patient. Sometimes it may take as much as 400 to 500 pounds of ice to cool a heatstroke victim's body back to normal temperature.

Humidity is an important factor leading to heatstroke because if the air is saturated, sweat will not evaporate. Sweat that is rolling off and dripping is not effective in cooling the body, so the person feels hot and uncomfortable.

Clothing is another contributing factor. If the body is all covered up in heavy clothing, sweat cannot evaporate.

Dehydration causes a major share of the deaths that occur in young athletes, he points out. "Not only should coaches provide the kids with water, but they should make sure that they drink it." Dehydration can cause the salt concentration in the blood to go extremely high. For this reason, the practice of taking salt tablets before exercising is highly dangerous. If you take salt without drinking a lot of water, there is no way your kidneys can get rid of the excess. The result may be dehydration and brain damage." Salt and the other essential nutrients lost in sweat should be taken during meals as part of a balanced diet.

Summer can be a gloriously fun time—especially if you're aware of the potential for heatstroke and avoid it by following simple, effective procedures. Happy summer!

FIND BURIED TREASURE

Find buried gold, silver, coins, treasures with powerful new electronic detector. Ultra sensitive. Penetrates deep into earth. Works through mud, beach sand, rock, wood, etc. Signals when object is detected.

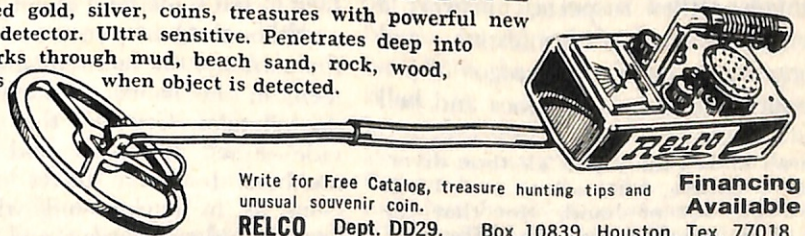

Write for Free Catalog, treasure hunting tips and unusual souvenir coin. **Financing Available**
RELCO Dept. DD29, Box 10839, Houston, Tex. 77018

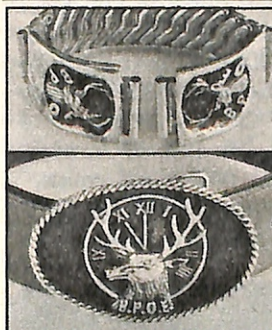

NEW FOR THE ELKS MAN

These beautifully hand-crafted pieces of Elk styled jewelry will make a handsome gift, or buy it for yourself, you deserve it. All pieces are unconditionally guaranteed against breakage.

Watch band, belt buckle and bolo tie are available in silver plate or gold plate; your choice at one low price.

Watch band—\$19.95. Belt buckle—\$16.95. Bolo tie—\$12.95. Price includes shipping and handling. Please allow up to 3 weeks delivery time from date order is placed.

When ordering, be sure to specify gold or silver. To order thru:

BankAmericard ■ VISA ■ Master Charge (check one)

Fill in card numbers & expiration date below. date

Send all orders to J&L Enterprises, P.O. Box 486, Montebello, CA 90640, (213) 724-6407.



"QUINCY:" A Bone Of Contention

by Warren H. Spencer

The setting is innocuous enough—a bustling California university where an assistant Los Angeles County Medical Examiner named Quincy is conducting a seminar in investigative pathology. Across campus, construction workers are plowing up the terrain for a new building when suddenly they uncover a single human bone. As luck would have it, one of Quincy's students stumbles upon the find, blabs to the professor and the entire project grinds to a halt as students and teacher prospect for more remains. It's all to no avail, however, and they are left with a single femur, a thigh bone. Yet from that frail bit of human frame, Quincy meticulously reconstructs the owner, a young Nordic male who didn't just die; he was murdered! But that's not all. Along the way, the rumpiled medical examiner rattles suspects, uncovers a killer, provokes a confession and emerges once again as a paragon of justice surrounded by test tubes and bell jars.

It all makes for super TV-time diversion, of course, but sad to say things get a bit out of hand. Not that the rest of us would know the difference, but there are real-life Quincys out there, and they do know. They're an elite and slightly esoteric group of scientists known as forensic anthropologists. For the most part, they are physical anthropologists who traditionally dabble with the remains of ancient civilizations. But from time to time, they become involved with this one. And

with certification granted by the American Academy of Forensic Sciences, they are qualified to testify in court concerning the remains of the dearly departed. Throughout the nation, they know—all 20 or so of them—that Quincy just can't do the things he does.

"That particular episode is the one on which we have gotten the most feedback," says Dr. Clyde Snow, chief of Physical Anthropology Research at the Federal Aviation Administration's Aeronautical Center in Oklahoma City. "I think they had some rather poor technical advice. From a single thigh bone, we can estimate a person's stature; we can get some idea of body build; it's a pretty good indicator of sex and we might get some hints as to race. But our approach is the reverse of Quincy's. We start out with a person's face to tell something about his femur."

Although Quincy may carry things to the extreme, the fact remains that dead men, in the hands of trained experts, do tell tales. Granted, they don't provide street addresses and telephone numbers, but bare bones often yield clues as to background which often lead to identification and, in some rare cases, may even point to a murder suspect. Such was not the case with Elmer McCurdy. Everyone knew who killed him. Yet establishing his identity and tracing his travels—even as a corpse—proved to be one of forensic anthropology's most publicized coups.

"Appropriately enough, late in 1976 a crew was filming a sequence of the

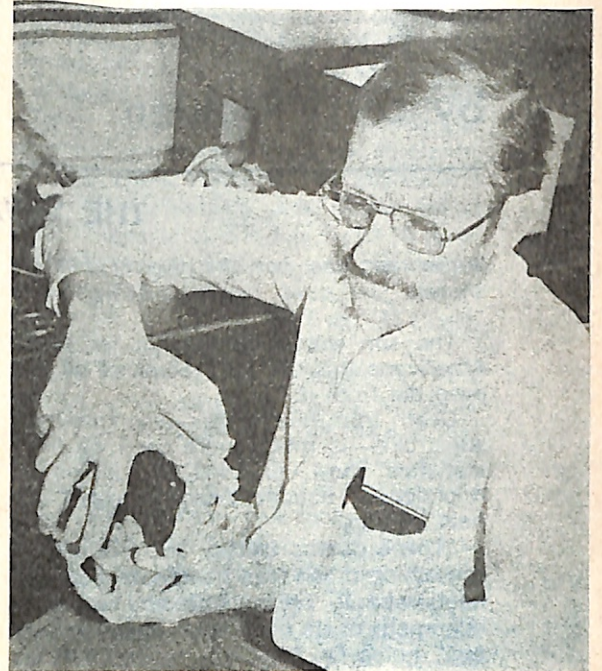

Dr. Dick McWilliams (above), anthropology professor at the University of Nebraska-Lincoln, explains the pelvic bone is a sure indication of sex. A ridge inside the skull (center), above what would be the roof of the mouth, is a prime indicator of age. While scientific tools are used, most measurements and reconstructions are rule-of-thumb, resulting from years of experience.

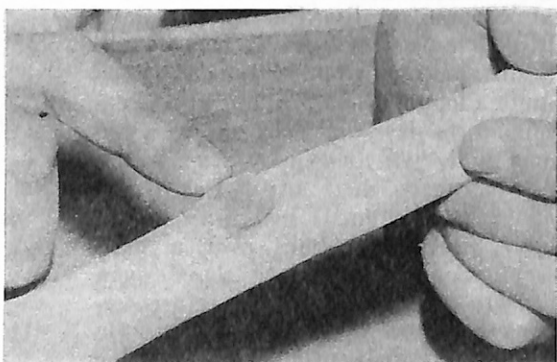
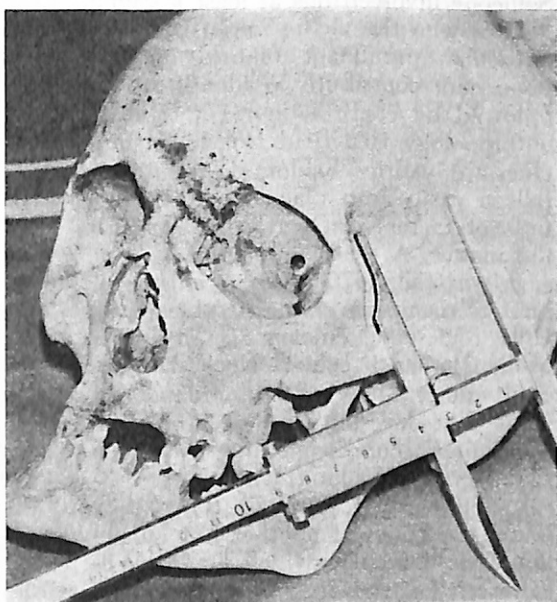
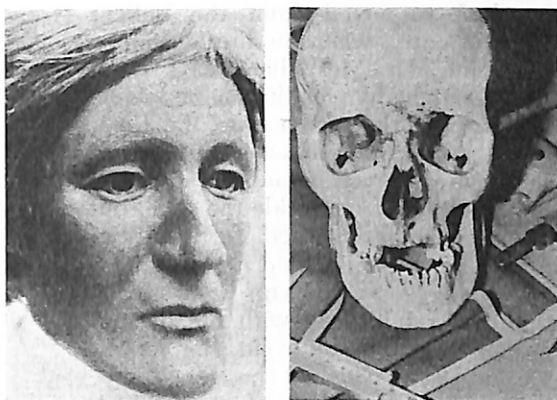

Chances are that no one will ever know how close the reconstruction (above, left) comes to resembling the living human being. Results are good (85 to 90 percent) but can only be gauged when identification is made. Indications are that the Hooker County remains (above right) are those of a drug addict. Wherever a muscle attaches to a bone (bottom), the surface is roughened.

'Six Million Dollar Man' at a place called the 'Laugh in the Dark Funhouse' near Los Angeles," Dr. Snow recalls. "One scene called for some footage inside the funhouse, and one of the props was a dummy, suspended from the ceiling by a noose around its neck. The thing was wax-coated and covered with a special red paint so it would glow under black light. During the shooting, a cameraman wanted a better shot of it, so he sent his assistant over to move the dummy. When the assistant grabbed the arm, it came off and there was a bone inside!"

That discovery involved the local authorities who demanded to know where the body came from. Nobody knew. So the remains were moved to the Los Angeles County Medical Examiner's Office (coincidentally, Quincy's hangout) for investigation, while the police continued to quiz the funhouse owner.

"Finally, they found the man who originally acquired the dummy," Dr. Snow says. "He had picked it up from a down-and-out carnival owner back in the 1930s. The carnay owner put up Elmer—of course nobody knew it was Elmer at the time—as security on a loan, then dropped out of sight. So, the dummy just stayed in the funhouse."

Meanwhile, back at the Medical Examiner's Office, technicians began peeling away layers of paint and wax. Underneath, they found a well-mummified white male, complete with bullet hole. Further, toxicology reports showed the body was brimming with arsenic. Better known today as a lethal poison, the element was used in the United States until the early 1900s as an embalming agent. Nonetheless, when the bullet and arsenic findings hit the press, the whole nation listened.

"The authorities began to hear from people throughout the West who remembered seeing the body in the early part of this century," Dr. Snow reports, "and we finally traced it back to Oklahoma. We're still getting background information, but we think now that Elmer might have been born somewhere up in Kansas or Colorado. In 1911, though, he was in Oklahoma

where he tried to rob a train running out of Coffeyville, Kansas.

"There were two trains through each day, and the one that Elmer wanted was carrying a payroll of around \$25,000 or \$30,000. He and two accomplices pulled off a beautiful robbery, but apparently Elmer was a Number One Screwup. The three of them stopped the train, uncoupled the engine and the baggage car and pulled them on up the track, leaving the passengers marooned out in the middle of no-

"Although Quincy may carry things to the extreme, the fact remains that dead men do tell tales..."

where. Then the trio began ransacking the baggage car, but when they found the money box, there was only \$46 in it. They had hit the wrong train! Oklahoma was a dry state, though, and they uncovered an illegal consignment of whiskey, so they grabbed that and lit out. When last seen that day, Elmer was in possession of two demijohns of liquor."

Although exactly what happened next is a bit clouded, evidently earning just \$46 for his efforts had Elmer a bit out of sorts. Instead of heading for the border, he started drinking. A night or two later, he turned up, drunk as a skunk, at a neighborhood ranch where he traded some of his remaining whiskey for a night's lodging in the barn. Before he could strike out the next morning, however, a posse showed up. Elmer wouldn't come out, and after an hour-long gun battle, Elmer McCurdy was dead.

"They hauled him over to Pawhuska, Oklahoma, the nearest large town, and photographed him the way he was, then again after the embalmer was finished," Dr. Snow notes. "Since no one knew of any next of kin, the mortician loaded Elmer down with arsenic, then

A Bone Of Contention

stuck him up in a back room of his funeral parlor. The local country folk would come into town, and for a nickel they could go in and look at Elmer. It was something to do on Saturday night. Then, around 1915, a stranger showed up in town, plunked down his nickel and went into shock. Elmer, he moaned, was his brother, and he demanded the body. It should be removed for burial beside ma and pa on the home place, he said. As it turned out, though, the fellow wasn't a relation, but a carnival owner who wanted Elmer for his own show." So Elmer's travels began.

They really didn't end until mid-1977 when he returned to Oklahoma. Sixty-six years after his best-laid plans went awry, Elmer McCurdy was buried amid pomp and circumstance at the territorial capital of Guthrie. Nearby are salt-of-the-earth pioneer homesteaders, a couple of governors and more than a few outlaws. Elmer, it seems, should be proud.

With all of its show-business and Old West trappings, the McCurdy cast is atypical of forensic anthropologists' fare for a couple of reasons. One, investigators had a complete (albeit slightly altered) body to work with. Two, in his own way, Elmer had been something of a showman, maybe even a celebrity. Still, it wasn't the type of case which would interest Quincy. There just wasn't any social or moral injustice to set right. He would have been more interested, perhaps, in Glen Cleveland Crawford's posthumous encounter with the forensic anthropologist.

"In the late 1960s, Crawford was a small-time hood in Moore, an Oklahoma City suburb," recalls Dr. Dick McWilliams, a professor of anthropology at the University of Nebraska-Lincoln who was involved in the case with Dr. Snow. "For some reason, he had a

falling-out with his wife and her brother. The first we knew about it was when a farmer's dog drug the skull into the farmyard. That's the way these things happen about 90 percent of the time, it seems. So, the authorities began a search, finally bringing most of the skeleton and some forearm flesh which had been preserved by wet oak leaves in the ditch where the body had been dumped."

A quick examination of the remains revealed a bullet hole behind the left ear, and another in the sternum or breast bone. Beyond that, the scientists were unable to determine little more than that the remains were those of a white European male.

"I was working down in the lab, and put the flesh into a jar of formaldehyde to preserve it," Dr. McWilliams remembers. "Because of decay and the tanning action of the oak leaves, the flesh was the color of deep mahogany. But the chemical bleached it out, and under ultraviolet light we could see a bunch of tattoos. One was a monkey with the word 'Skeeter' etched beneath it, and the artwork was the kind a prison inmate might do himself.

"By that time, the police, who kept a pretty close watch on Crawford, noticed that he hadn't been seen for a few weeks. So they began to speculate that the remains we had might be him. Working on that possibility, we got hold of his police record and all the photographs we could find. Sure enough, in one of the booking photos, we could see his entire torso and lower arms, and there was the monkey tattoo with the word 'Skeeter.' What's more, records showed that because his wife was little, Crawford's pet names for her were 'Little Monkey' and 'Skeeter.' That made it unlikely that our remains were anyone else's."

According to Dr. McWilliams, the ensuing psychological warfare would have been worthy of a "Quincy" episode. Dr. Snow began leaking bits

and pieces of information to the press, spiced with predictions that the police were getting closer and closer to identifying the victim, even the killer or killers. Simultaneously, the police were applying pressure to the next of kin. Finally, the murderers cracked.

"Eventually, we learned that Crawford had been lying down, something we had suspected from the bullet's angle of entry, when the brother-in-law shot him," Dr. McWilliams says. "The bullet caught him in the chest, knocking him off the couch onto the floor. Then, the brother-in-law administered the coup de grace behind the ear. We had the bullet from inside the skull, but it was too fragmented for ballistics tests. The one which had hit him in the chest was gone, perhaps it went on through or fell away with the decomposing tissue. In any event, the confession was what clinched the case."

Those are the kinds of cases which any forensic scientist would welcome: Someone involved has at least a vague idea of who the victim might be. Or a particular prominent feature on the bone may contribute to identification, followed by confirmation. Yet forensic anthropology is a field in which such clues are luxuries. Seldom do the pieces fall so easily into place, and a multitude of factors can surface to confuse the matter. A case in point:

It was fall 1976 when a cluster of hunters roamed over the desolate Sand Hills region of Hooker County near Mullen in north central Nebraska. Records don't show the abundance of game that day, but they do state that the hunters found something for which they were not looking. On a barren escarpment called Dismal Rim, they found the bones of another human being. It is a case in which Dr. McWilliams has become deeply involved.

"I got him—or what was left of him—around the first of December," Dr. McWilliams recalls. "He was completely skeletonized; there was hair but no flesh. That might hint that he had died quite a long time before. But in alternating warm days and cold nights, a human body will decompose rapidly; so he may have died just a few weeks earlier. And animals had been at the body, scattering bones over a wide area. Consequently, we have very little to work with. Still, there are certain things we know about him: He was a white male, probably around age 20, but no older than 24. I know his race because he has a face like the bow of a ship, the bone formation narrowing from the back of the skull to the front. And I can be certain of race because of the notch on the bridge of the nose, the place where glasses would rest. The rule of thumb is that if the

(Continued on page 31)

CASH SAVINGS CERTIFICATE

SAVE \$20.00
with this special certificate

This cash certificate entitles you to a \$20.00 savings on the exciting new solar powered watches pictured in the advertisement on page 7. When this certificate accompanies your order you may deduct \$20.00 from the regular purchase price.

SEE OUR ADVERTISEMENT ON PAGE 7 IN THIS MAGAZINE

Electronics International 210 S. Desplaines St. Chicago, Ill. 60608

YOU AND RETIREMENT

by Grace W. Weinstein



MEDICARE AND HEALTH INSURANCE

What does Medicare provide? As an insurance floor, it has two compartments. **Medicare Part A** covers in-hospital costs, post-hospital extended care in a "skilled nursing facility," and certain post-hospital care in your own home. Part A covers all those 65 and over who qualify for Social Security. But it isn't automatic; you must apply, preferably before your 65th birthday—whether or not you intend to start receiving retirement benefits at that time. Part A covers inpatient hospital bills, except for the first \$144, for the first 60 days. Between 60 and 90 days you must pay \$36 a day and, after 90 days, \$72 a day. These costs have risen steadily, along with hospital costs; in 1966 the deductible for Part A was \$40.

Medicare Part B, a voluntary medical insurance plan for which you must enroll and pay a premium (\$8.20 a month as of July 1, 1978), pays 80 percent of medical bills each year after the first \$60. Medical bills are defined as physicians' services wherever they are received, up to 100 home nursing visits in a year, and such other services as diagnostic X-rays, laboratory tests, splints and casts, and some ambulance services. For maximum protection, try to get your doctor to accept Medicare payments made directly to him. If he does not do so, Medicare may disallow part of the claim—and you will have to make up the difference.

Most people also need supplemental private health insurance. This can be costly. It can also be confusing. The American Council of Life Insurance suggests some steps to take:

- ✓ Find out whether you can continue your on-the-job group health insurance coverage, if you have any, as supplementary insurance. More and more companies are tailoring their group health insurance to dovetail with Medicare and provide complementary coverage for employees and former employees who reach retirement age. Find out, from your company's personnel office, preferably before retirement. Even with such extended coverage, however, there may still be gaps. If so:

- ✓ To supplement your continued group insurance coverage, take out a "hospital income" or "hospital indemnity" policy. This is not actually health insurance but a form of insurance that provides cash dollars during a hospital stay to cover expenses not otherwise covered, such as

private duty nurses. Look for a policy that provides at least \$40 to \$50 a day from the first day of hospitalization.

- ✓ If your group insurance will not continue, and you must rely on Medicare alone, do *not* take a fixed amount indemnity policy. Instead, take a "wraparound" or "Medigap" policy designed to fill in as many of the gaps as possible: to pay Medicare's deductible and the required co-insurance, to pay for private-duty nursing, and to pay (at least in part) for drugs and medical supplies.

- ✓ If you already carry major medical, think long and hard before you drop it. This is good, and usually relatively inexpensive, coverage if you buy it earlier and can continue it past age 65. It may, in some cases, be convertible to a "wrap-around" policy.

- ✓ Get a second opinion before elective surgery. This is not a vote of "no-confidence" in your own doctor, but a recognition that, when it comes to non-emergency surgery, there are legitimate differences of opinion among experts. In a program begun by Blue Cross-Blue Shield of Greater New York in 1976, one out of four recommendations for surgery was not confirmed by a consulting physician.

© If you do have to enter the hospital, ask your doctor about Pre-Admission Testing. You may be able to receive routine pre-admission tests as an outpatient, postponing hospital care and costs until they are actually needed.

© Stay out of the hospital on weekends if you possibly can. Patients admitted to the hospital on Fridays and Saturdays, Blue Cross and Blue Shield of Michigan found, are likely to have longer, and more expensive—hospital stays.

© Take advantage of tax deductions for medical bills and for health insurance. One-half of insurance premiums for health insurance, up to \$150 a year, are tax deductible; if you and your spouse are both enrolled in Medicare Part B, your combined annual premium (once the rate increase takes effect in July) will be \$196.80. Travel costs for medical care are also deductible. For example, if you use your own car, you are allowed seven cents a mile.

© Buy the best health insurance you can afford. But do not over-insure, or buy expensive but limited policies, such as those that insure only against a single illness. ■



Ride up and down stairs.

Install an *Inclinette*

Inclinette is the safe and easy way for the handicapped or elderly to ride up and down stairs with just a push of the button. And . . . it's tax deductible when recommended by a doctor.

SEND FOR FREE LITERATURE Describes and illustrates Inclinette. Also, StairLIFT, the economy model, and "Elevette", the modern home elevator.

INCLINATOR COMPANY OF AMERICA
2218 Paxton St., Harrisburg, Pa. 17105
In business for over 50 years

UNIQUE UNWRAPPER OPENS CRIMPED END COIN ROLLS

EASY TO USE

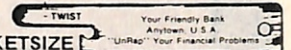

ALUMINUM-POCKETSIZE

Bankers, tellers, checkout persons — save your fingernails, spilled coin and banging on cash drawer. ONLY \$1.00 PPD., BROMLEY, R. # 5, Dowagiac, MI 49047.

OIL and YOU

You in the oil business? Yes! And for only \$20.00. Write for free information on how you can enter this monthly lottery for gov. oil land in Wyoming on an equal footing with the large oil companies. Winnings often are worth tens of thousands of dollars. Simply clip this ad and mail with your name and address to **WARBY ENTERPRISES**, 2003 E. 15th, Cheyenne, Wyo. 82001.

FOREIGN COIN COLLECTING HOBBY KITS— DELUXE WORLD'S COINS

\$ 80 different uncirculated Foreign Coins from 80 countries around the world. Appeals to families & growing children. \$21: 40 Foreign Coins World Album, \$15: 16 coins of the World Album "Peace" \$7: 32 fully illustrated pages picturing & describing each coin & its country origin. 10 Foreign Coins different countries. \$4.

Helser, Inc., 314 Main, Dept. E, Watertown, WI 53094

MODERN - OBSOLETE - FOREIGN DOMESTIC - MILITARY - SPORTING

WORLD'S LARGEST SUPPLIER
GIANT CATALOG #7
\$2.00 PPD

GUN-PARTS

NUMRICH ARMS CORP.
Box ELK, West Hurley, New York 12491



ELECTRIFY YOUR BIKE!

PEDALPOWER exciting new bike drive tames tough hills. Be independent. Shop when you want. Fits all Bikes, Adult Trikes. Installs in minutes. Thousands sold. Recharges overnight. Travels 100 miles for a dime. Call or send for FREE illustrated booklet.

CALL FREE
800-257-7955

GENERAL ENGINES CO.,
5043 Mantua Blvd., Sewell, N.J. 08080

Do You Suffer From Morning Mouth?

Kick the dirty Nicotine Habit with a unique guaranteed incentive method . . . **JOGGING!** This proven graduated jogging system reduces the desire to smoke. As you progress, you eliminate your addiction to cigarettes. You're challenged to stop puffing. Also no worries about gaining pounds from increased eating. Make life smell and taste better. Send \$3.95, plus 80¢ for postage and handling to:

Smoke Screen Motivation
P.O. Box 1125, New Brunswick, N.J. 08903
N.J. Residents, add 5% for Sales Tax



the two salesmen stood looking quietly out of the large glass door of the automobile agency. The corpulent one was expensively attired; his thin co-worker, who was somewhat taller, wore a cheap, baggy bargain-store suit.

The obese salesman was snapping the fingers of both hands rhythmically, describing arcs at his sides with each snap. Finally, bored, he broke the silence.

"Quiet, isn't it, Al?"

"Yeah, Louie."

They were wordless again, but the finger-snapping continued.

Louie inhaled tiredly. "It's been three days, already."

"Yeah."

Suddenly, Louie stopped snapping. One of his fatty eyelids raised; the other crinkled and half eclipsed an eyeball. "Hey, what's that?" he said.

Far off down the road, someone was emerging from the dense forest.

Louie's voice was slightly higher than usual. "Where the hell did *he* come from?"

Al scratched a pale ear. "Darned if *I* know. There ain't nothing behind them woods but that funny farm, Cheery Knoll."

The auto agents continued watching as the distant figure began to approach along the road.

"Do you think he's coming here?" Louie asked.

"Could be," replied the other salesman. "There ain't no other business around here but us, except way up the highway, and it looks like he's headed in this here direction."

Louie clapped his palms together. "Great! We got to wrap this one up!"

The two salesmen waited impatiently as the wayfarer continued toward them. They were soon able to discern his appearance in more detail. He was neatly dressed, about forty-five, and had sharply-chiseled features. His inscrutable, almost hypnotic, eyes glinted in the sun.

After the lengthy trek, the stranger finally reached the automobile showroom. Louie swung the door open for him.

"Good morning, sir," said the portly salesman.

"Good morning," the new arrival replied, entering.

"Want to buy a car?" Al asked.

"I prefer buying it," said the customer. "It is more of a challenge that way."

Louie gave his friend a cutting glance. "Of course, he does! Why else would he come here?" He smiled brightly at the potential buyer.

"What've 'ya got in mind?" Al asked.

Louie put a restraining palm on Al's shoulder. "Let's show him what we got and let him decide for himself, huh?"

The customer wandered ahead of them into the display room. His almost transparent pupils took in the three shiny models that stood parked on the floor. The two salesmen were at his heels.



the extras are extra

by Audrey and Harvey Bilker

"This is nice," the visitor remarked, looking at the hard-top. He paused. "It will do."

"Nice?" Louie exclaimed. "That's putting it mildly. . . Mr. . . uhh. . ."

"Klar." Louie repeated mechanically. "This is the best of the three. The most expensive, but the best. A real beauty." He put his hand on the sleek fender. "She can really take the road. Smooth. Trouble-free. A real buy."

"They are all suitable," said the customer. "But this one is properly functional. I want a representative vehicle."

Louie and Al turned slowly to each other, then back to the customer.

"This is fifty-five hundred," Louie said. "Plus tax." He waited.

"I will take it."

"Right now?" Louie asked.

"Yes, right now."

Louie fingered his rubbery lips warily. "Mr. Klar, before we can sell you this car, we have to check out your credit."

"Credit? For cash?" the buyer replied.

Louie's eyebrows went up. "Cash?"

"Yes," said Klar, reaching into his pants pocket and removing a fat roll of crisp bills. He opened them flat and ran his thumb over one edge the way a dealer would with cards. The salesman watched, mesmerized, as the number 100 kept repeating.

Louie cleared his throat. "Fine," he said casually. "I'll get a contract." He snapped his fingers at his partner. "Al, come on back to the office with me, will you? I'll need your help."

They left Klar and went into the large room in the rear where two clerks were typing.

Louie settled his bulk into a swivel chair at one of the empty desks and put his hands in his lap. "Al, I hate to say this, but something's fishy. No guy walks into an auto dealers and makes his mind up like that.

"Yeah, maybe you're right," Al said.

"Of course, I'm right," Louie insisted. "Especially, nobody pays cash like that, or carries such a big bankroll around. Hmmm," he pondered. "Could be some nut who escaped from Cheery Knoll."

Al nodded his head a few times. "Yeah, you're right, Louie—about everything. Let's go out there and tell him to forget it."

"What?" countered Louie.

"Didn't you just say that—?"

"You idiot!" Louie rolled his eyes high in their sockets and shook his head. "I'm just speculating. There are all sorts of crazy people in this world. Maybe this guy is nuts, but just isn't locked up. Maybe he's some kind of rich eccentric."

"Hey, that's right, Louie," Al agreed. "And you know, you're always right."

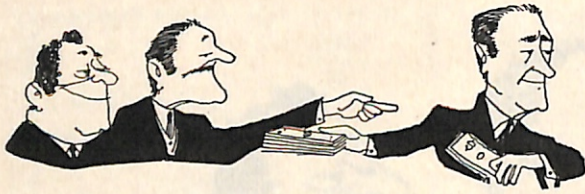

"Look, Al," said the heavy salesman, "if this guy is on the up and up, we got ourselves a nice commission—right on the spot. Today! Cash!"

"Yeah, but what if he is one of them nuts?"

"With that kind of loot? Not too likely. They don't let them have any money. At least not a wad of dough like *that*." He reached into the desk and withdrew a set of contracts. "Let's close the deal."

Al followed Louie out into the showroom. Klar was still standing where they had left him, inspecting the car he had chosen.

"Mr. Klar," Louie said. "Let's write this up. But first—well, I don't want to be insulting, sir—but I'd like to see if you have the . . . full amount. And also, if you don't mind, I'd like to check your bills." He touched his fingertips delicately against his silk tie. "You see, a man walks in here with five and a half G's, we got to be careful. Know what I mean? No offense to you, I hope."

Klar smiled wisely. "Of course not," he replied. "I understand your position completely." He reached into his pocket, pulled out the money again, and counted off fifty-five crisp, new, hundred-dollar bills. He handed them to Louie, who took them to a small table in the corner of the large showroom. Al tagged after him.

As Louie began snapping each bill down, his pale gray eyes lit up green. He took a magnifying glass out of the table drawer and studied several of the hundreds. Then he checked the serial numbers against a list taped on the wall. Al stood behind him tensely watching over his shoulder.

Louie whispered to his friend. "They look good to me." He held up a couple of

notes for Al to see. "None of these numbers are on the list, and they're all different." He tapped the stack of money back into a uniform block and returned to Klar. Al followed timidly behind.

"Mr. Klar," Louie announced, still holding the money, "all is in order." He led the way to a Formica-topped showroom table where they all sat on plastic and metal-tubed contour chairs. He put carbon paper between the contracts and lined them up. "Now," he said, cheerfully businesslike, "we got extras we can put on—like power steering, power brakes, radio, and so on."

Klar's forehead creased. "Are they not included?"

"No," said Louie. "The extras are extra."

"Very well," said Klar.

Louie poised his ball-point pen. "First, power brakes. Only a hundred and seven bucks."

"Yes," said Klar. "I will take them."

"Radio. AM-FM, one-seventy-five," the salesman went on.

"Add that, too," replied the customer.

Al swallowed nervously, but kept silent.

"Let's see," Louie said, grasping his chin. "Power steering, one-sixty-two."

"I will take it," said Klar.

"Air-conditioning, six-oh-five."

"Yes."

As Louie was writing, his facial expression gradually transformed into a demeanor of realization. He lifted his head slowly, his eyes unfocusing. "Al," he said. "Would you come with me, please? Excuse us for a second, Mr. Klar. I have to check the list in the back on some prices for other extras."

Al again tailed after his friend.

In the quiet of the back office, Louie said, "This guy'll take *anything!* Look, what do you say we charge him for some things that come *with* the car?"

The other salesman's head slowly tilted to the side. "Ain't that taking a chance?" he asked.

"With *him?*"

Al blinked his eyes. "I don't know. . ."

"Listen," Louie explained excitedly. "He's paying cash." His gestures became animated. "We make the contract out for all the regular extras—at the end. But first we make up a list and add on a few phoney items. We charge him for *everything*, but we give him the papers for the regular amount. Get it?"

He raised his porky shoulders. "You think he's gonna look at the contract?" he asked knowingly. He waited for Al to reply. But there was no response, just dazed expression. So Louie answered himself. "Of course not."

"But what if he questions it?" Al said.

"Then we say 'Oops, we made a mistake!' and I re-do the list and tell him it's a good thing he asked, we made a mistake." He put his hands on his bulging hips. "But, believe me, Al, this guy won't ask."

Al shrugged. "Okay, if you say so. You're always right."

Louie led the other salesman back into the showroom. Klar was still sitting at the table.

When they were all seated together once more, Louie continued from where he had left off. "Let's see." He paused, mustering up strength for the first move. This was the test. In a burst, he said, "What about seats?"

"Seats?" asked Klar.

"Yeah," Louie replied, his eyes fixed on a blank piece of paper he had placed in front of him. His manner was strained and he tapped his pen in a fast staccato. "Front and back. Only three hundred."

"Yes, I will need those," the customer said.

Louie flashed a quick grin at Al, then hunched over and marked the item down on his separate list. "Now, let's see?" he wondered aloud, looking off. "How about tires?"

"Yeah," Al chimed in with newly-discovered self-confidence. "Mr. Klar, we got some beauts. Only a hundred bucks apiece." He looked over at his accomplice for a complimentary response, but Louie was busy writing up the items.

When the customer immediately agreed, Louie continued his notations, and mumbled, "And wheels, of course, two hundred." Then he said, "I suggest you take a steering wheel."

"That's right," Al hurriedly interjected. "It helps to turn the car."

Louie looked up and shot his partner a critical look.

Klar noticed Louie's censure and defended Al. "He is absolutely right. I will take that, too."

"Mmmmm, what else?" Louie muttered almost to himself, bumping his fat knees together under the table. "I've got it. What about pedals?"

Americanism and Flag Day Contest Brochures

Lodges and State Associations submitting brochures in the annual Americanism and Flag Day Contest should mail their entries to:

James W. Damon, Chairman
Grand Lodge Americanism Committee, BPOE
c/o Town and Country Hotel
500 Hotel Circle
San Diego, CA 92138
ATTN: Jim Cunningham, Convention Manager
Hold for Elks Convention

Contest rules, including the Division entry instructions plus suggestions on preparing your brochures, are contained on pages 13, 14, and 15 of the 1977-78 Americanism Program booklet.

ELKS NATIONAL SERVICE COMMISSION

"So long as there is a disabled veteran in our hospitals, the Benevolent and Protective Order of Elks will never forget him."

Honor Roll of District Deputies 1977-78

The Elks National Service Commission is privileged to list the outstanding District Deputies and State National Service Committee Chairmen whose leadership produced 100 percent participation in the 1977-1978 Veterans Remembrance Participation Report. We further acknowledge our gratitude to Grand Lodge State Associations Committee Chairman Richard W. Squires who supervised this significant contribution to the welfare of America's hospitalized veterans. We record with pride the accomplishments of the following 1977-1978 District Deputies:

Theodore J. Wade/AZ East Central
Thomas E. Thompson/AZ North
Earl L. Wilford/AZ Southeast
Arthur L. Livingston/AZ Southwest
Murry E. Hodge/AR East
C. Ray Goodner/AR West
Robert Summitt/CA Bay
Elba E. Jones/CA Central
R. E. Cenis/CA East Central
Max G. Handley/CA Inland
Eugene P. Weigand/CA Metropolitan
Leroy Maben/CA North
Haven S. Blaylock/CA North Central
Robert J. Burke/CA Northwest
Dave Homewood/CA Orange Coast
Earl M. Green/CA South
Victor J. Vidal/CA South Central
Richard Mansell/CA South Central Coast
Harold Jacobson, Jr./CA South Coast
Carl H. Sappington/CA Southeast
Walter E. Hartshorn/CA West Central
Norman J. Asbridge/CA West Central Coast
James M. Steers/CO Central Northwest
John W. Heard/CO North
Thomas F. Dorsey/CT East
John B. Kuzmak/CT Northwest
John Bertinasco/CT South Central
Robert H. Clark/CT Southeast
Arthur M. Thoman/FL East Central
Steven C. Merena/FL South Southeast
Robert N. Thomas/FL West Central
Cleghorn P. McKee/HI
Lou E. Morton/ID Central
J. D. Bassett, Jr./ID East
Norman E. Bauer/ID North
Arthur M. Smith/ID North Central
L. Dan Rowell/ID South
Edward J. Comisky/IL East Central
W. E. Lumley/IL Northwest
N. J. Barker/IL South
Paul J. Seelman/IL Southwest
Floyd A. Coultas/IL West Central
Carl W. Larcom/KS Southeast
Adjutor Pare/ME East
William J. Rowe/ME West
William Robert Wilhelm/MD, DE & DC North Central
Elwood M. Hazel/MD, DE & DC Northeast
H. Mac Brittingham/MD, DE & DC Southeast
Marland Deen/MD, DE & DC Southwest
Alfred S. Williams, Sr./MD, DE & DC West
Edward R. Ardini/MA Circle
Edward P. Volta/MA East
James J. Sugrue/MA East Central
Leo E. Dawson/MA Metropolitan
Daniel J. Moynihan/MA North
Frank H. Trifoglio/MA South
John J. Morrissey/MA West
William J. Kallio/MA West Central
Welton L. Davis/MI East

Michael D. Leslie/MI East Central
Earl E. Anderson/MI Northeast
Robert K. Watts/MI Northwest
John J. Whorley/MI South Central
Donald E. Laubengayer/MI Southeast
H. Keith Waltke/MI Southwest
Terry Minor/MI West Central
Alfred Becker/MN Central
Thomas R. Heitzinger/MN Metropolitan
John W. Rogers/MT Central
Thomas R. Balcer/MT East
Wayne W. Van Atta/MT North
Karl L. Sauerbier/MT South
Joe Montgomery/MT West
William A. Lechner/NE Central
Leighton A. Washburn/NH North
Edward J. LeBlanc/NH South
Harry L. Newton/NJ East
Frank Brinkofski/NJ East
Arthur A. Cutillo/NJ East Central
Ernest Thomaier/NJ North
Americo F. Masucci/NJ North Central
Edward F. Glace, Jr./NJ Northeast
Ronald S. Butto/NJ Northwest
Walter P. Kennedy/NJ South
Elmer F. Magee/NJ South Central
Leroy Wutsch/NJ Southeast
Francis J. Patsy/NJ Southwest
Bruce A. Bailey/NJ West Central
Dwight H. Ray/NM Northeast
Stuart Rucker/NM Northwest
Thomas W. Burkett/NM Southeast
William H. Evans/NM Southwest
Ernest H. Savage/NY Central
Vernon H. Allinson/NY East
Albert A. Favoino/NY East Central
Frank D. Turner/NY North
William Farmer/NY North Central
Raymond A. Daley/NY Notheast
Harvey Bayer/NY South
James Marcy/NY South Central
Edward J. Sullo/NY Southeast
Keith R. Miller/NY Southwest
William J. Janeski/NY State Capitol
Leon C. Bennett/NY West
Franklin B. Tigh/NY West Central
J. Byron Long/NC East Central
Robert C. Baker/NC West Central
Neal Whitley/OK Northeast
James I. Maxwell/OK Northwest
Gordon Varva/OK Southwest
Richard E. Heath/OR Metropolitan
James P. Fowler/OR North Central
George G. Richardson/OR Northeast
E. Lewis Crites/OR Northwest
Don Abraham/OR South Central
Oscar A. DeNault/OR Southeast
Doug Peterson/OR Southwest
Sherman W. Coudriet/PA North Central

George K. Pugh/PA South Central
Bob J. Huffman/PA West
Howard J. Surber, Jr./RI East
Angelo A. Lombardo, Sr./RI West
Ted P. Mickelson/SD East
A. M. Schultz/SD West
John P. Land/TN Upper East
Vic F. Elliott/TX Central
Harlan M. Starnes/TX Gulf Coast
Lee Zastovnik/TX North
John H. Golden/TX Northeast
C. H. Matthies, Jr./TX Southwest
Carl C. Williams/TX West
Ray Dufour/UT North
Richard T. Brown/UT South
Richard J. Bove/VT North
Victor E. Shaw/VT South
Richard W. Collier, Jr./VA Southeast
Robert Hillin/WA Metropolitan
Lee B. Bowden/WA Northeast
John V. Gubrud/WA Northwest
Carl M. Bush/WA Puget Sound
Charles G. Picatti/WA Southeast
Fred Oakes, Jr./WA Southwest
Stan Sarver/WA West Central
James R. Carpenter/WV Central
John R. Gray/WI Southwest

Honor Roll of States 1977-1978

Chairmen who achieved 100 percent participation from each lodge in state:

Kermit J. Bressner /Arizona
Raymond B. Fischer/Arkansas
John F. Jordan/California-Hawaii
Thomas Blanchard & William Mangan/Connecticut
Burl Kirkpatrick/Idaho
Edward R. Twomey/Maine
Paul D. Helsel/Maryland, Delaware & District of Columbia
Henry Gibbons/Massachusetts
Frank G. Stobbart/Michigan
Lloyd E. Lamb & Robert R. Lamb/Montana
Bud Stillwagon/New Hampshire
Frank J. McCann/New Jersey
Duane Jacklin/New Mexico
George Malekian/New York
Wally Wright/Oregon
Ernest Faiola/Rhode Island
Albert DeGroot/South Dakota
Bill Van Talge/Utah
Philip J. Trachier/Vermont
Al Ludington/Washington

ELIMINATES DAILY DENTURE "FIXINGS" FOREVER

Snug Cushions hold dentures comfortably tight for weeks

No more "fixings" every morning with messy powders or creams. Even if dentures need "fixing" after every meal, here's important news. Snug cushions restore dentures' holding power so dentures stay comfortably tight for weeks. Snug, the soft, effective temporary aid, forms a "comfort bond" between dentures and gums. Sticks to dentures, not to gums. Rinse, scrub or soak Snug fresh and clean. Easy to remove, but won't wash off or flake away. So, end daily "fixings"! Use Snug to hold dentures comfortably tight for weeks.

SNUG
DENTURE CUSHIONS

4 Real Old Coins \$2.50

2 different Indian Head Pennies minted before 1909 and 2 different Buffalo Nickels before 1939.

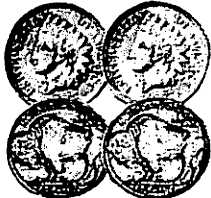

ALL 4 SCARCE COINS ONLY \$2.50
Add 25¢ postage. Immediate shipment.
Catalog included. Satisfaction guaranteed
Village Coin Shop Dept. E
PLAISTOW, N.H. 03865

IN SUNNY SPAIN

NEW HOMES

\$14,970 full price

CONDOMINIUMS

\$4,990 full price

An excellent opportunity to own or lease for income. For full details and color brochure including terms, floor plans, buy-back guarantee, leasing, etc., send \$1.00 to:

Anthony J. Pycraft, Agent
13837 Ventura Blvd., Suite 1-E
Sherman Oaks, CA 91423

WIN BIG OIL MONEY
PLUS TAX BENEFITS

OTHERS DO EVERY MONTH IN U.S. GOVERNMENT OIL LEASE DRAWINGS. IF YOU ARE 21 AND A CITIZEN YOU CAN PARTICIPATE EQUALLY WITH MAJOR OIL COMPANIES IN THIS LEGAL LOTTERY. A \$25. TAX DEDUCTIBLE FILING FEE CAN RETURN UP TO \$75,000 AND MORE IMMEDIATELY PLUS A POSSIBLE FORTUNE IN FUTURE INCOME WRITE DEPT. 7 FOR FREE INFORMATION.

F. MILLIGAN INC., 600 MANHATTAN, BOULDER, CO 80503

HEARING AIDS
MAIL ORDER SAVINGS
WRITE TODAY FOR DISCOUNT-PRICES ON YOUR FAVORITE MODELS

Behind the ear and all-in-the-ear and eyeglasses and body aids

From \$89 Send to:
ELECTRONIC PRODUCTS
Hearing Aid Division
P.O. Box 2005, Pinellas Park, FLA 33565

Interested in ARIZONA?

If you have an interest in or curiosity about The Mystical State of Arizona: I have the facts. Comprehensive publications list available. Send \$1.25 (postage & handling) to Michelle's Area Information Center, Box 1931, Scottsdale, Arizona 85252.

REMBRANDT DID IT IN OILS...

Let us do it in
BRONZE PLAQUES
FOR ALL OCCASIONS

Write for Free Catalog E23
Engraved Plaques E21

INTERNATIONAL BRONZE TABLET CO., INC.
150 W. 22nd St., N.Y., N.Y. 10011 212-WA 4-2323

Bike Racing Returns

(Continued from page 10)

comes around high up on the bank and drops down like a bat out of hell at 50 miles an hour and takes the lead—like Donaghy just did—and I'm going nuts because now I'm that dark horse and I'm *beating* the champ, beating the pants off him!"

That's the kind of excitement the Trexlertown Velodrome has engendered. And it's spreading. San Diego now has a velodrome patterned after the one in Trexlertown and three or four others are under construction near major American cities.

All in all, there are now 13 velodromes in the United States, most of them constructed on concrete or asphalt, built in the 1960s for local recreational use through funds from city or county departments of parks and recreation. That's the case with the velodromes in San Jose, California, Northbrook, Illinois, and Kissena, New York. In other towns, among them Detroit and St. Louis, the local government has teamed up with private bicycling clubs to share the building and maintenance expenses. In East Point, Georgia, the Federal Bureau of Outdoor Recreation also participated. The Dick Lane Velodrome in East Point also has a full-time director now, courtesy of a grant from the U.S. Department of Labor.

One velodrome, in Alpenrose, Oregon, was built and is maintained by a company, the Alpenrose Dairy.

We've built 10 velodromes in this country in the past 16 years, and that's some progress. But it's nothing compared to what's ahead. Within the next 24 months, as many as 11 new velodromes will open, four of them in California, two in Florida, and others in Kentucky, Michigan, Minnesota, New Mexico, Ohio, and perhaps Tucson, Ari-

Romantic Hideaways

(Continued from page 8)

ton's new hotel is surrounded by a championship 18-hole golf course on the shore of Keuhi Beach. Guests sail aboard catamarans or paddle beyond the breakers in outrigger canoes. Figure on \$41 to \$49-a-day for a single, or \$44 to \$52 for a couple.

Returning to the Big Island, there is Boise Cascade's development near the great, windswept Parker Ranch (the largest cattle ranch under single ownership in the U.S.). The Boise people are developing what promises to become Hawaii's resort of the future. What with 50,000 acres, there's room to ride, rope and roam at will. So far Boise's parcel contains a mere 120 homes and 38 condominiums—all of it lost on a chunk of land bigger than the city of San Francisco, bigger even than

zona. What's more, a Michigan company recently completed a portable wooden velodrome that can be transported in three 40-foot trailers and assembled in an ice hockey arena. It's now touring the country.

Old-time bicycle enthusiasts are getting the message: Professional management and a reasonable gate (\$1.00 to \$2.50 at Trexlertown) can make bicycle racing a paying and fascinating sport again.

And local clubs and businesses are eager to get behind it, not only for the publicity but because they believe in the substantial ideals of physical excellence, fair competition and wholesome outdoor activity. In Trexlertown, companies as varied as the multimillion dollar Air Products and the local Pizza Hut franchiser buy advertising space on the track's wooden outer fence. A club may put up the entire evening's prize money. A local philanthropist may underwrite an entire weekend. Stimulating such generosity is one of the things Jack Simes and Dave Chauner get paid for.

Bicycle racing's coming back in the U.S.—no doubt about it. In 1976, we did better in the Olympics than we have in half a century, and Jack Simes says we have enough top cyclists training at velodromes across America now to assure us an Olympics medal in 1980, a feat we haven't managed since 1904. There's even some vague talk of building an indoor velodrome, a posh Churchhill Downs-type place where the spectators can watch the races in air-conditioned comfort and spend lots of money on mint juleps—and carrot juice cocktails, too, if Bob Rodale has his way.

And, if things go according to plan, Eddy Merckx, the world's favorite athlete, just may be racing in Trexlertown, Pennsylvania, in 1979.

Washington, DC. Reaching out from great lava flows, it brings to mind the desolate beauty of a moonscape, with snowcapped Mauna Kea towering in the background. One day the Kohala Coast will be Hawaii's Gold Coast, islanders say. Boise's long-range plans involve half a dozen hotels along this stretch of beach not far from Laurance Rockefeller's world-famous Mauna Kea Beach Hotel which was sold recently to Western International.

Presently Boise's only rentals are the handful of condominiums that rise along an 18-hole golf course. The hitch here is that they are nine miles uphill from the ocean. Although transportation is provided to and from Aanehoomalu Bay, the distance turns off certain guests. They would rather stay put and just dunk in a swimming pool adjoining the clubhouse and tennis courts.

the extras are extra

(Continued from page 26)

"That's right!" Al said. "We can give you a good deal on those. Only a hundred bucks."

Louie moved his eyebrows together. "What're you talking about? You want him to get cheap ones? Listen, Mr. Klar. We got a set for two-fifty'll last you forever."

Klar's face was stern, but he said nothing. He just nodded his head automatically in approval.

Louie furrowed his brow and pondered profoundly. Then, with timed deliberateness, he snapped his fingers at Klar. "Of course!" He looked at Al, then Klar again. "How about a motor?" We can give you the best for only eight hundred."

"No," Klar said resolutely.

Louie's eyes bulged and he turned them nervously to his partner, then paused. Perspiration appeared on his forehead. "I'll tell you what. You're buying quite a bit. I'll give it to you for six-fifty."

"I do not want it," said Klar.

Al swallowed. "How about four hundred?"

Klar shook his head from side to side.

"Three?" said Louie.

"No."

"Two?" Al put in.

Louie hit the table with his fist in the manner of an auctioneer. "One-fifty!"

"No, thank you," replied the customer.

Louie inhaled deeply. "Look. Since you're such a good customer, we'll throw the motor in free."

The two car salesmen settled back contentedly in their seats.

Klar smiled gently. "Gentlemen, you are both very kind. But I do not want the motor. I do not need it."

The salesmen's faces dulled.

"Mr. Klar," Louie said after a brief silence, "you can *have* it. Don't you understand? We're *giving* it to you."

"I appreciate that, gentlemen. But I assure you, it is not necessary." He took out the balance of his roll of money. "I assume you have a car in stock at present into which you can put the extras at once?"

Louie hesitated. "Actually," he said, "all the ones that have been shipped here have motors in them. All of our customers usually take *that* extra."

"That is all right," Klar said. "Just remove it. If there is any charge, just put it on the list."

Al dangled a limp palm over the table. "But how're you—?"

Louie put a finger up immediately before Al's face. "Whatever you want, Mr. Klar. But remember, there'll be a charge to put it back in."

"That will not be necessary."

"Okay, then," Louie replied with resignation. "Let's just close the deal." He first completed the formal legal papers, then filled out the contract for the actual price of the car and legitimate extras. But the total he quoted Klar was from his separate sheet and included all the extras, and the tax on everything. Klar signed, paid the balance of the cash, and took his copy of the contract.

As Louie had hoped, Klar didn't look at the contract. The new owner folded the paper twice, and put it in his pocket.

"We'll have the car for you as soon as we can, Mr. Klar," Louie explained. "It shouldn't take too long. Why don't you make yourself comfortable? Al, you come with me."

The two salesmen went through a pair of double doors into the service area.

Several mechanics were working on cars parked on the floor, or on hydraulic lifts, in the bays. There was the mixed odor of paint and oil and the clanging of tools and metal.

"Hey, Ed," Louie called.

An elderly man, somewhat gaunt, came up to him. His face was smeared with grease. He wore soiled overalls with his name stitched in red on one top pocket. "What's up?" he asked, wiping his hands on an oily rag.

"We got a rush job. Customer's waiting."

"Okay," Ed replied. "What's to be done?"

"A new car. He wants the motor taken out."

The mechanic stopped short in the midst of wiping his hands. "You out of your tubes?"

"Nope."

Ed scratched his neck with a dirty fingernail and laughed. "What part's he taking? The car or the motor?"

"The car," Louie replied grumpily. "And he wants that white hard-top with all the extras we just got in."

Ed shrugged. "Okay Whatever you say," he replied, and went off chuckling.

The new car was driven in from the back lot shipment and parked in an empty bay. Ed, with assistance from a few other mechanics, got to work.

After a while, when the car was ready, Louie, followed by Al, marched triumphantly to the showroom waiting area where their customer was sitting patiently. Louie still held all of the money, which he and Al had pleurably counted numerous times since the sale and which was now damp and wilted.

"We're all set, Mr. Klar," the plump salesman said. "They're rolling it around front for you."

(Continued on next page)



• About two years ago, while in the service, my son was robbed and shot in the spine. He is now 100 percent disabled and must wear a very heavy leg brace.

In the article "Space-Age Medicine," (April, 1978) by L. B. Taylor, Jr., about medical spin-offs from space-age technology there is reference to a new "graphite epoxy" material used for leg braces. These are said to be much lighter than traditional leg braces.

Where can I get more information?

Henry Cieslowski
Union City, CT

• . . . I am interested in learning where I can get more information about such leg braces.

E. D. Auer
Grangeville, ID

The leg brace of epoxy composite material is being tested at NASA's Langley Research Center. It is said to show great promise.

For further information you can write directly to John Samos, NASA Technology Utilization Office, Langley Research Center, Hampton, VA 23665.

L. B. Taylor, Jr.

• Found Richard Wolkomir's article on smoke detector's in the March, 1977, issue very informative. (Also noticed his article was reprinted in the January, 1978, edition of *The Catholic Digest*.)

Since seeing the article I have looked all over, for the photoelectric type of alarm. While I can find lots of information, I have yet to find a source where I can purchase such an alarm.

All stores seem to sell the ionization type of alarm. I do not want this type. I want the photoelectric type without any ionization or radioactive material in its make-up.

R. J. Lochner, C.S.C.
Lake Park, Florida

I suspect one reason why ionization detectors may be more popular is that they draw less electricity and so are better adapted to battery power. With batteries you can install a detector anywhere, regardless of proximity to outlets. In an independent test of ionization detectors by Consumers Union, they were found to emit less radiation than the general background radiation, always present in nature, so they should be safe. Especially if there are no children who can reach them and take them apart.

While hard to find, photoelectric alarms are available. Montgomery Ward, for example, lists two models in their catalog.
Richard Wolkomir

Letters must be signed and may be edited. Address to: Letter Editor, *The Elks Magazine*, 425 West Diversey, Chicago, Illinois 60614.

**NO EXPERIENCE
NECESSARY**

We can PUT YOU in a HIGH VOLUME CASH BUSINESS that's an irresistible traffic stopper. This very portable computer portrait system requires an investment you can afford and quickly recoup. NO PHOTO OR COMPUTER EXPERIENCE IS NECESSARY!

Portraits made in just 55 sec. are easily transferred to many products — T-shirts to calendars, all high mark-up, big profit items FOR YOU! Ideal for part/full time or absentee management. TO SEE BIG PROFITS ACT NOW!

CASH

COMPUTER AMUSEMENT SYSTEMS, INC.
11 West 20 St., New York, NY 10011 / Dept. E
(212) 929-8355



**ELKS
ROAD SIGNS**

Welcome visiting Elks to your Lodge by erecting these signs on highways into your city. 30" Emblem sign in official colors. Fiberglass Reinforced Plastic—strong, lightweight; 10" x 24" "Modulite" plate with 3 lines of lettering.

\$39.40 F.O.B. Factory Pennsylvania
2 or more, same lettering, **\$37.40 ea.**

Allow 4 weeks for shipment (We do not supply post)

To serve you better, we have moved to larger, more modern quarters.



RUSSELL-HAMPTON CO.

Dept. E, 2550 Wisconsin Avenue
Downers Grove, Illinois 60515
(A Chicago Suburb)



**FOR PERMANENT
FUND RAISING**

Easy way to raise money for your Organization because everyone has fun playing BINGO! Thousands of Organizations are making up to \$500.00 per week using "BINGO KING" supplies and FREE Idea Bulletins. Write for FREE catalog and details on raising money for your Organization.

PLEASE GIVE NAME OF ORGANIZATION.

'BINGO KING'

DEPT. 807B, BOX 2499, LITTLETON, COLO. 80161

JOKES FOR SPEAKERS!

Topical Joke-Bulletin with approx. 100 funny one-liners, stories and roast-lines. Created by top Hollywood comedy writers. Ideal for Business and Club meetings, Banquets, etc. Humorize your speech for any audience; any occasion. Current issue, \$5.00. Send check or m.o. to:

JOKES UN-LTD.

1357 Miller Dr. Dept. E-4, Hollywood, Calif. 90069

HEARING AIDS

\$UPER SAVINGS! Newest, Finest. All types. Buy DIRECT & save up to HALF! No salesmen. Sold by AIR MAIL on HOME TRIAL. FREE Catalog. Write: **MONEYSAVERS**, Dept. EK-7, 9530 Langdon Ave., Sepulveda, Cal. 91343

SAVE 1/2!

FREE CATALOG — WRITE!

"HOW TO FLATTEN YOUR STOMACH"®

by Coach Jim Everroad

Illustrated Program for Men and Women—not a "gimmick"! Send \$1.75 plus 25¢ postage and handling.

JDC Co.—Box 55358H
Indianapolis, Indiana 46205

(Continued from previous page)

Klar's face grew into a smile of satisfaction. "Good."

The two salesmen and their customer went outside and waited. From around the side of the building came the car. Four straining, puffing mechanics were pushing it, including Ed, who had his hand in the driver's window on the steering wheel. Following them was the sound of a heavy motor growling and a transmission shifting; it belonged to a tow truck which appeared.

"That's for you," Louie said apologetically to Klar, pointing to the wrecker. "Just in case you can't get the car going. We'll tow it to your place, compliments of the house."

"That is very nice of you," replied Klar. "But I will take it back home myself."

The new car was pushed along the auto agency's driveway, up to the road.

When the men backed away into a group, Klar went to the automobile and opened the hood. The two salesmen and four mechanics tried to suppress an infectious, uncontrolled giggling started by Ed.

Klar reached into his pocket and removed a small object. The others couldn't tell what it was since he held it entirely in his fist, but they could

see a number of silvery threads dangling from it.

The onlookers were unable to tell what Klar was doing as he leaned into the space where the motor had been. His arms moved with confidence and expertise.

Then the customer closed the hood and got into the car.

Inside, he leaned down as if he were working on something under the dashboard. Through the side window, the six men from the agency could see only a head bent over, and raised shoulders.

Klar sat up again, powered up his window, gave a friendly good-bye wave to the curious watchers, and winked at Louie and Al.

As the car began to roll forward—uphill—the six observers' faces froze. Klar inched the auto onto the highway, braked, looked both ways, then turned into the empty lane.

The car accelerated.

Louie, the cash clenched in his fist, looked open-mouthed at Al—who returned a blank stare; then they both turned back to join with the four mechanics in watching after Klar.

As the car traveled off down the road, it became transparent, then vanished. At the same time, so did the money that Louie gripped.

Major Projects

(Continued from page 12)

one to the campgrounds. Walking off the dock and across the beach, one passes the camp lodge and the staff house on the way to the play field, which has tennis and basketball courts and swings. A group of buildings, including the dining hall, health facility, and director's cabin, lies beyond the field. Routing back towards the lake, passing the flag pole and wash house, one comes upon six cabins. Finally, the council ring, with a camp fire at its center, breaks the boundary between wood and beach.

At 7:45 a.m. the campers are roused from their beds and daily activities begin. After flag raising and breakfast, the cabins are cleaned and any improvement projects are continued. One youngster might then work with arts and crafts or go on a hike, while another may study nature or engage in a sport. Before lunch, the water front is bustling with activity and after the meal, the campers spend an hour resting. The afternoon activities are similar to those of the morning, and after dinner everyone may participate in a softball or volleyball game. The night's blanket of stars can be examined through a telescope's eye, and gathering around the camp fire is a usual way to end the campers' busy day.

The typical daily schedule may certainly vary. Special events include talent and award nights, a carnival, trips, Indian understanding day, a track meet, and treasure hunts. In order to participate in this camp life, a child need only have his parents contact their local lodge for in-

formation. The camp accepts any deserving youngster without regard to race, religion, or background. All fees are paid by Minnesota Elks and so a child who would not ordinarily have the opportunity to attend camp, is given the chance to have this summer experience.

Each year \$55,000-\$60,000 is spent on running the camp. No state-wide fund-raising affairs are held, but each camper is supported by 50 Brothers through quotas assigned to the lodges. Supplies for the various activities are donated and the items needed are listed in the state publication. Provisions such as those for arts and crafts, kitchen needs, and hardware are asked for every year. One year a lodge contributed a diving raft to the camp.

A rewarding summer experience which includes character growth and informal education is the goal of the Minnesota State Elks Youth Camp. The staff is chosen with great care and with the acknowledgement that the counselors have a large role in the quality of the camp life. A nurse, who administers to any health needs the campers and counselors might have, is part of the staff. Hospital facilities are only 15 minutes away in Brainerd, where a doctor is available at any time.

In August, 1976, the American Camping Association visited the camp and examined their records. The Association found that its standards of safety, programming, and personnel were satisfied, and in December the Minnesota State Elks Youth Camp received their accreditation. The Association recognized the high quality of the camp that the Brothers of Minnesota sought to maintain.

A Bone Of Contention

skull is Caucasian, you can place a finger on that notch and roll the head back. And I know the sex because of formation of the pelvic bone, among other things. His age is determined by a joint inside the skull which closes at about age 26. That joint is still open in this skull. Too, the molars are fresh, not worn.

Cause of death? I don't know, says Dr. McWilliams. He's dead. There's a reason for the dearth of information. Unlike the fictional Quincy, real-life forensic scientists, in this case anthropologists, can't be sure of anything which doesn't mark the bone. That isn't to say, however, that there wasn't some clue found among these remains. At this point, it is all scientific guesswork, but there is an indication that the bones belonged to a right-handed laborer, judging from the roughness of the bone of the upper right arm. Where muscles—any muscles—attach to the bone, they roughen the surface. In this case, a distinct hump appears where the bicep would join. That leads Dr. McWilliams to speculate that the man probably did heavy labor, perhaps swinging a spike hammer on the railroad.

Additionally, there is a good indication that the remains belonged to a drug addict.

"It is possible that he wasn't," Dr. McWilliams explains, "but it's not very likely, because all of his teeth are rotten. He's a young man, and he's white. Young white men usually take care of their teeth, that is unless they are addicts. Then, the habit comes above everything else, and dental care is far from a priority. Too, an addict's teeth go bad unusually fast because he frequently has a sugar addiction along with everything else."

Strong evidence exists that the youth was in either the military or prison. That speculation is based on a partial plate which replaces all of his upper front teeth.

"I'm not ruling out military service in favor of the prison theory, but the latter seems more realistic," Dr. McWilliams explains. "At his age, it's likely that he would have been turned down for military service because of his addiction. He would have had to have been an addict for some time—long enough to rot his teeth. And then there is the plate. It's cheap. By many standards it's not inexpensive, but it's the kind that would be made for an inmate of an institution."

When found, the man's clothing contained nothing—no personal effects, no laundry marks, no form of identification.

So, the current theory is that he was a drifter, an itinerant who came from nowhere on his way to nowhere. What happens next in such cases? How does Dr. McWilliams ferret out a mysterious past? Well, in fact, he has gone about as far as he can. The rest is up to the general public; perhaps someone somewhere will recognize the face and get in touch. For there is a bit of Quincy in the forensic anthropologist. He can restore a face. Such restorations often are the only avenues to identification.

"Facial reconstructions are amazingly accurate," Dr. McWilliams notes. "Our track record, in cases where we eventually learn the identity, is about 85 to 90 percent that the likeness is close enough for friends or relatives to make an accurate identification. An Oklahoma City woman, Betty Gatliff, does our reconstructions. In fact, she did the one on Glen Crawford, and it proved amazingly accurate. We had it sitting on a desk when an officer involved in the case walked in. His first reaction was, 'Hell, that's Crawford.'"

Reconstruction is impossible without a skull to work from. With it, however, using a scientifically developed formula for tissue thickness, clay is substituted for missing flesh. The result is to simulate an individual's face as it appeared in life. There are problems, though, and women pose the greatest obstacle to a 100 percent effectiveness rating.

"Young men are the best for reconstruction," Dr. McWilliams points out. "But women modify their faces so much with makeup, and they have a variable, extra layer of sub-cutaneous fat which cannot be gauged by studying the skull. And older women are the hardest. We can restore only an average individual—we can't put in the wrinkles and scars. So, if a woman was 81 at death, we would produce a reconstruction in which she looked 21."

The Hooker County remains are those of a young man, but identification may still come slowly, if ever. Authorities simply don't know where to begin, particularly after publication of the reconstruction throughout Nebraska produced no results. As Dr. McWilliams points out, there are 49 other states in which to look, and if identification ever is made it will be a matter of luck.

Quincy wouldn't admit such limitations, of course. But then he is nothing more than the creation of a television writer's imagination. Perhaps that's why he will go on, for the time being at least, combining science and tenacity to unravel one impossible case after another. And, although their voices probably never will be heard as one, a tiny chorus of forensic anthropologists throughout the nation will continue with each episode to moan: "Hey! He can't do that!" ■

The Fraternal Corner

It was hot and humid when the Grand Lodge Session of 1911 convened in Atlantic City, NJ. With the open air layout of the convention hall to catch the cooling ocean breezes, the sounds of the boardwalk sometimes filtered in making it occasionally difficult for the delegates to hear.

The subject of changes in the Elks Ritual was brought up. Changing the ritual had become a pastime at Grand Lodge Sessions as members sought to provide a ritual that was purely Elk.

It had been five years since any action had been taken and the Committee on Work and Ritual was ready and waiting.

They suggested a reduction in the ritual from 5,708 words to a mere 3,610.

They proposed:

- ✓ Complete elimination of Part II, which contained the horseplay features.
- ✓ Abandonment of the preliminary obligation.
- ✓ Abandonment of the test oath.
- ✓ Omission of the Chaplain's recitation.
- ✓ Shortening the real obligation.
- ✓ Making optional the legend in the Leading Knight's part.
- ✓ The omission of the eulogy to the Flag.

When the adoption of the changes was moved, a young attorney from Atlanta, GA, No. 78, Walter P. Andrews, jumped to his feet in protest.

"I would regret exceedingly to see the eulogy to the Flag eliminated from that charge. It is the most beautiful thing in the whole ceremony of Elkdom.

There was an awkward pause.

Past Grand Exalted Ruler Will English of Indianapolis No. 13 took the floor.

"Before we vote on it," he said, "I would suggest that Brother Andrews give us the eulogy to the Flag."

Andrews, perhaps, hadn't counted on this.

It was a dramatic moment.

The delegates probably rose to their feet and saluted the Flag, as Walter spoke with a soft southern accent and in an eloquent voice: "... There is no such red in budding rose, in falling leaf or sparkling wine ..."

When he was through there was a brief moment of silence. And then the convention exploded into loud and prolonged applause.

Fred Harper of Lynchburg Lodge No. 321, a member of the committee, put it this way:

"I think I may speak for the Ritual Committee ... In view of the demonstration you have just had in approval of the eulogy of the Flag, the committee would be willing to accept the amendment ..."

The Exalted Ruler's tribute to the Flag was retained and to this day is one of the highlights of the Exalted Ruler's charge and the Flag Day ritual. ■

A Nation of Runaways

(Continued from page 6)

There are much more desperate cases.

"A girl came here once, a tiny little thing," Devance's face livens with the memory of the first meeting. "She was so sweet, a little doll, just 12-years old. We found out she'd been on the street for two years, a prostitute.

"Could we help her? Not really."

Project Place is not geared to help all youngsters in trouble. The shelter refuses Department of Youth Services kids, ones already hardened into junior criminals by years in detention.

The doors are open to juveniles recommended through the courts, hospitals, outreach centers, or just plain kids who walk in off the street—as long as they behave.

"We try not to hang onto the tough kids," Devance explains, "because we don't have the facilities to help them. And when they go (run off), they drag others with them. We get a lot of rural runaways who've never been to Boston before. They're pretty naive, so we try to get them home fast, away from the more experienced ones."

The "experienced" runaways come to shelters such as Project Place at 15 years old, already on the road for a half dozen years. "You know they're tough to survive that long on the streets," Devance sums up.

The terrors of the street for a teenager in need of money are well documented. "Kiddie pornography," drug pushing, boy and girl prostitution are the easiest ways for a minor to make a living. Former runaways, in fact, are the major source of the country's prostitutes, according to police.

If a person is a juvenile (variously defined by states as under 19, 18, or 17) and has run from home, he has committed a "status offense," which means breaking a statute that does not apply to adults. Technically the runaway is no criminal. But he is probably wanted—by his parents and by the law.

So the runaway has the feeling of being on the run, outside the law, and when he needs help, as all do from the

start, he aligns himself with adults who use—and abuse—him for their own advantages.

One such adult was so bold as to rent an apartment across from a runaway shelter, siphoning off boys, then using them to coax others over. He amassed a harem of young runaways with a strict cash deal—money for sex.

The runaway has other physical, mental and emotional needs. Pregnant perhaps, afflicted with venereal disease, depressed by a tumultuous home life—the runaway has problems which fester as long as he or she is on the street and afraid to seek help from any "establishment" agency.

In New York City, police aren't waiting for the runaway to initiate the first contact. The "Runaway Unit," begun June, 1972, is a prototype for law enforcement dealing with the runaway epidemic.

"We look for kids who are dirty, or panhandling, something out of the usual," says Sgt. Jim Greenlay, director of the unit which mainly patrols Times Square, Washington Square Park, Greenwich Village and the Port Authority bus terminal.

"We get to know the regulars on the street," he says, "we can tell a kid who's not from New York."

The six officers assigned to the detail are so good, in fact, that about 85 percent of those youngsters stopped are from out of state, even if not runaways. The unit questions 80 to 90 youngsters a month and takes into custody about 40.

"We don't arrest them," the sergeant emphasizes. "We just take them off the street where they're victimized by everyone. Employers know they're underage and pay them less, hotels charge more, pimps know they're easy marks. We think the runaway is better off somewhere receiving food, discipline, and medical care."

Sometimes the runaway himself doesn't agree and tries to bolt. But working in pairs, the unit patrolmen usually have no difficulty taking firm but gentle control. Twenty-four states allow juveniles without a home to be picked up and detained.

The first step, discovering the youth's name and address, is sometimes no easy chore. If the runaway refuses to identify himself, as 10 have done in 4½ years, then he is sent to the Bronx Detention Youth Center.

"He isn't mixed in with juvenile offenders," Greenlay says. "We're mandated to keep them separate."

Most runaways do cooperate and are rejoined to parents. If the youth is from out of state, then New York police operate under a reciprocity agreement, the Interstate Compact, which says the law of the youth's home state applies. A 16-year old from New Jersey (where the age of majority is 18), will be sent home even though New York law recognizes 16-year olds as adults.

In cases where the child alleges physical abuse, such as incest or beatings, the police may go to the courts for help in placing the child safely.

"We don't want to send kids back to a bad situation," Greenlay affirms. "But most of them run from good homes with parents who really miss them."

New York does not provide a free ride home. The runaway unit will escort a child to Kennedy Airport and make sure he boards, if parents prepay for the ticket at their local airport.

Neither local police nor runaway shelters are equipped financially or logistically to return children to homes across the country. Fortunately, someone is—Travelers Aid (T.A.).

"We're unique in dealing with runaways," boasts Director of Field Services Samuel Mopsik of his organization which is largely funded by the United Way. "We've been working with runaways long before they became a national problem."

Travelers Aid actually offers open-door assistance to anyone young or old, runaway or not, who feels displaced from home. The T.A. network covers 3000 cities through 75 agencies and an additional 800 cooperating representatives.

Only the Jacksonville, Florida, T.A. is a live-in shelter. In all other cities the T.A. focus is on linking parent and child in communication—within 24 hours.

"If T.A. in New York gets a kid from Oshkosh," theorizes Mopsik, "then the New York counselor contacts the representative in Oshkosh to personally notify the family. It might be necessary for the runaway to get counseling where he's at and the parents counseling where they're at."

Mopsik's national post at T.A. provides him with interesting insights into the runaway problem:

▶ "The average age is going down for runaways; 11 is not too frequent, 12 is."

(Continued on page 37)

Obituaries

PAST DISTRICT DEPUTY Thomas P. Golden died recently. Brother Golden, a member of San Diego, CA, Lodge, held the office of District Deputy Grand Exalted Ruler in 1957-1958 for California's South Coast District.

PAST DISTRICT DEPUTY Gerald A. Ayres of Houghton-Higgins Lake, MI, Lodge died recently. In 1975-1976, Brother Ayres was appointed District Deputy Grand Exalted Ruler for the East Central District.

PAST DISTRICT DEPUTY A. R. Chaffee of Ballard (Seattle), WA, Lodge died recently. Brother Chaffee was District Deputy Grand Exalted Ruler for the Metro District in 1974-1975.

PAST GRAND LODGE COMMITTEEMAN R. Lamar Johnston of Vero Beach, FL, Lodge died April 14, 1978. District Deputy Grand Exalted Ruler in 1963-1964, Brother Johnston was a member of the GL Committee on Credentials in 1973-1974.

LODGE VISITS

GRAND EXALTED RULER HOMER HUHN, JR.

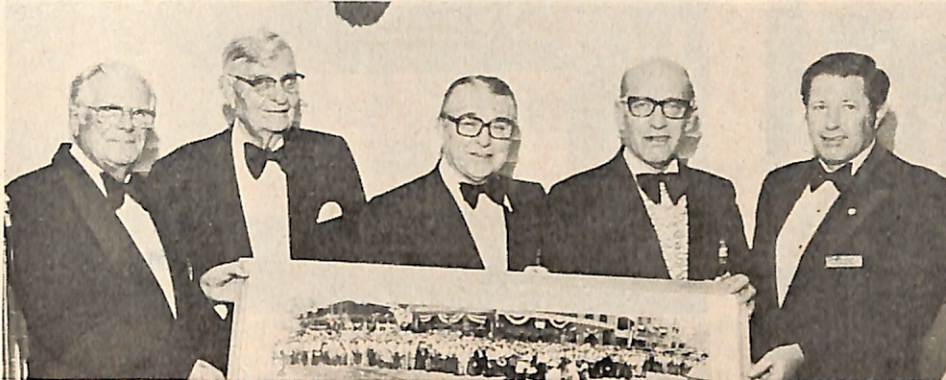

A delegate to the 1928 Grand Lodge Convention in Miami, FL, Brother John Miller (second from left), recently presented a picture of the 1928 conventioners to GER Homer Huhn, Jr. (second from right) for the Elks' archives. The occasion for the presentation of the photograph was a testimonial dinner honoring Grand Secy. Stanley Kocur (center), which was held at his home lodge in East Chicago, IN. PGER Glenn Miller (left) and ER James Fife, also present for the event, helped display the picture.



Georgia Elks who gathered at Waycross Lodge for a meeting recently were addressed by the Grand Exalted Ruler. SP Lem Purdom (right) welcomed (from left) PGER Robert Pruitt, state sponsor, and GER and Mrs. Homer Huhn, Jr. to the affair. Brother Huhn congratulated the Georgia Elks on their new major project, Elks Aidmore Children's Home, which received \$50,000 from the state lodges.



Local, state, and Grand Lodge officials joined 500 members and guests of Paris, TN, Lodge for the dedication of a new two-story building. GER Huhn (fourth from left) and PGERs Horace Wisely (fifth) and Edward McCabe (third) attended the ceremonies along with (from left) PER W. J. Neese, then-ER Donald Willoughby, ER Lee Greer, GL Committeeman Ted Callicott, SP Paul Elliott, and DDGER Robert Crattie.



A package of strip sirloin steaks was presented to GER Homer Huhn, Jr. (second from left) by SP Dale Janowski (second from right) on behalf of the Elks of Nebraska. Brother Huhn was accompanied by SDGER Vincent Collura (left) and PGER George Klein during his visits to Scottsbluff, Sidney, and Alliance, NE, Lodges.



The new State President of New Mexico, Greeley Myers (second from right), exchanged a welcoming handshake with GER Homer Huhn, Jr. (second from left) during the New Mexico Elks' recent convention. Also on hand for the occasion were PGER Robert Boney (left), Brother Myers's father-in-law, and PGER Edward McCabe, who installed the new state officer.

NEWS OF THE LODGES

(Continued from page 16)



IN APPRECIATION of Albuquerque, NM, Lodge's work in connection with assistance to dialysis patients, the Kidney Foundation of New Mexico presented a plaque of commendation to the Brothers. Barbara Vigil, Foundation president, was thanked by (from left) ER Kenneth Littell, Secy. Robert Van Driel, and Brother Hank Rudow.



A SPECIAL benefit dance was held by Cedar City, UT, Lodge to raise money for Scott Nelson, who became paralyzed from the chest down after a horseback riding accident. The \$3,600 check was presented by (front row, from left) ER Anton Lambert and Chm. Vee Wadsworth to Mrs. Debbie Nelson and Mr. and Mrs. Harris Nelson, who thanked the Brothers including committeemen Kay Cummings and (back row, from left) Richard Orr, Jay Peck, Don Bulloch, and Jack Miller.



THREE YOUNG ladies of the Lakewood, CA, Girl Scout Troop were honored when they received their First Class Scout certificates. ER Chester Hill (right) and Chm. Stuart Smith (third from right) presented the certificates on behalf of the local lodge to Miriam Edward (fourth), Cyndy Hoskins (fifth), and Lisa Lamboley (sixth), while (from left) Scout Leaders Mrs. Hoskins, Mrs. Lamboley, and Mrs. Faieta, field director, observed.



IN ORDER to raise money for their Cerebral Palsy Fund, El Cajon, CA, Lodge held their second annual follies recently. The Brothers and their wives performed at the veterans hospital in La Jolla, CA.



COLORFUL COSTUMES and painted faces were worn by the clowns of Arcadia, CA, Lodge during the recent Crazy Hat Parade held by the local recreation department. Brothers (back row, from left) Barney Crosby, PER Clifford Witherby, clown director, Earl Panick, Lou Sale and (front row) Dave Bencoter and John Hurley, who amused the children throughout the day, also entertain at various other community occasions.

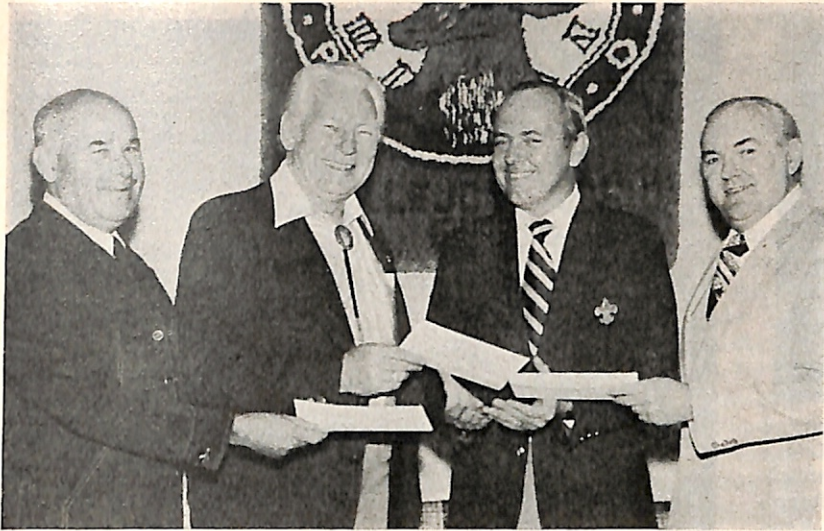

JOINING FORCES in support of the Boy Scouts, Vallejo, Clear Lake, and Napa, CA, Lodges contributed \$1,700 to Camp Silverado for improvements. Terry Tibor (second from right), Scout council executive, thanked (from left) Frank Hannis and ER John Chamberlin of Vallejo Lodge and ER Foster Pritchett of Napa Lodge for the contribution, which allowed the Scouts to qualify for an additional \$2,774 grant from the California Community Foundation.



PALM SPRINGS, California, Lodge paid tribute to PER Walter Colglazier (right) in proclaiming him Citizen of the Year. ER M. C. Manthey (left) presented the award and praised Brother Colglazier for his work in the community.



◀ **THE OFFICERS** of Glendive, MT, Lodge initiated a class of 35 members recently. ER Karl Overlie welcomed the new Brothers, who were introduced to Elkdom in honor of GER Homer Huhn, Jr.



THE ANNUAL Elks' ladies Eye Clinic benefit dance held at Corvallis, OR, Lodge raised \$3,223 for the Oregon State Elks Eye Clinic. Pres. Marilee Laux (right) presented a plaque of appreciation to Brother Billy Raye, who has donated his time and talent as bandleader for the past four ladies' benefit dances.



TO CELEBRATE SP Donald Luce's (second from left) homecoming, Richmond, CA, Lodge held a dinner attended by over 220 people. PGERs Horace Wisely, R. Leonard Bush, and Gerald Strohm addressed the assembly which included (from left) Millie Luce, Aileen and ER Carl Crisler, and Chm. James Dyer.



AMONG the new Brothers initiated in a ceremony in honor of Elk of the Year Anthony Williams of Bordentown, NJ, Lodge were Kevin Lynch (second from left) and Michael Loretangeli, who are cadets at the Naval Academy at Annapolis. PER Joseph Lynch (left) congratulated his son, and ER Raymond Kelly (right) welcomed Brother Loretangeli.

A THIRD generation member of the Suleski family became a member of Holyoke, MA, Lodge. Edward Suleski Jr. (left) was joined by his grandfather Joseph (second from left), his father Edward Sr. (fourth), and ER Albert Sabourin following the initiation ceremony, which was held at the lodge.



BROTHER Val Farinacci (center) congratulated his sons (from left) John, Anthony, and Jim, whom he sponsored for membership in Kinderhook, NY, Lodge. ER John Savosky was on hand to welcome the three new Farinaccis to the order.



SCHOLARSHIP recipients Jodi Lynn Edge (second from left) and Mark Vosvick (third) were congratulated by Wheeling, WV, Lodge's ER Daniel Manners and State Scholarship Chm. Leslie Jones. The two students were given \$200 checks each for their academic futures.



OFFICERS of the Burke family of Ukiah, CA, Lodge recently gathered to congratulate Juanita Burke (center) upon her installation as president of the Elks' ladies. Mrs. Burke's husband DDGER Robert J. (right) and son ER Robert F. congratulated the new family official.



A Nation of Runaways

(Continued from page 32)

- ▶ "A pattern going on for some time is a greater number of intra-city runaways rather than city to city."
- ▶ "T.A. used to see a lot of youthful drug addicts, now youthful alcoholics."
- ▶ "People generally don't like runaways, so they take the easiest way out in dealing with them."
- ▶ "A runaway isn't a runaway until he's reported or caught, and thousands go unaccounted for."
- ▶ "It seems more females run away only because more ask for help and are counted."

Mopsik further claims that "analysis of the runaway caseload is a barometer of things to come in society."

What, then, does it say about American society that there is an increasing number of "throwaways," children driven out of their home?

For 17-year-old Mark, "the first thing is to get back to San Diego."

He has run away from home several times, spending 1½ years on the road. But most recently he was handed \$20 pocket money and sent 2000 miles away.

"My mother just decided I was in the way," explains this earnest young man the first full day at Project Place. "I haven't seen my father in six years, my mother's remarried twice," Mark says, as if that explains it all from his viewpoint.

Some runaways may gravitate to, even ask for sexual or drug involvement in a search for thrills. Not Mark.

"I've seen a lot of disgusting things in my short life from running away," he begins. "They should close the Combat Zone, there's all kinds of freaks there. If any guy puts a hand on me I'll kill him. 'The Plaza' in San Diego is the same, only twice as big."

He knows the streets are bad, so he has come to Project Place—but as the lesser of two evils.

"Theoretically it's supposed to be better in a shelter," Mark says, "but it can be as violent as anything on the street. In Cambridge (MA) I slept with a baseball bat, a big 36-incher, right next to my bed. Another place, a 10-inch blade.

"I was in a group center once out West where these guys tried to electrocute me in my sleep. Somebody plugged an iron in a socket and stuck it on me."

It's easy to understand why this runaway/throwaway says, "I don't trust people. You trust somebody, they screw you."

Though he disdains the company of "criminals," Mark also doesn't have "much use for the cops. I don't need a record."

Beyond his immediate goal of get-

ting home, Mark plans to enter the Navy in a year.

"I'll just be a swabbie," he says, "I don't ask for much."

Mark has, though, asked Project Place for a place to sleep and T.A. for help getting back to San Diego.

As one of America's throwaways—now numbering about seven percent (about 70,000 yearly) of the runaway total—Mark is eager to establish the links that will take him home. In the more typical case, the runaway is trying to avoid detection by frantic families.

Community agencies uniformly refuse to be the willing or unwitting arm of the parents. Devance recalls Boston-area parents calling up Project Place saying, "If my son shows up, hold him there and call me, I'll come down."

"We don't do that," Devance says simply. "We always let the kid know what we're doing, whether it's calling his parents or the courts or a foster home."

Getting a message of their child's safety through a runaway hotline is enough for some parents. But others badger and threaten switchboard personnel to learn where the message came from.

"I tell them we don't have the information," says Marilyn Davidson, assistant coordinator of Peace of Mind. "We really don't know where the child is calling from. We wouldn't let parents look at our records anyway. They'd have to get a search warrant from the governor's office in Austin, and even then there's nothing to find here."

Both the Houston and Chicago hotlines purposely operate on a double-blind system. The runaway may wish to give his parents the typical message: "I'm safe. Don't worry. I love you. I'll keep in touch."

In such a case, the hotline asks for the name of the runaway, address of parents, and some bit of information (nickname, grandmother's name, for instance) to absolutely identify himself. All this information is maintained *without* any mention of the caller's location. The runaway phones back the hotline to receive any response from his parents and to place additional messages.

A wholly separate file records referrals—those cases where the runaway is directed to a community agency. Obviously, the location of the caller is known here, but not more than a first name or name to go by accompanies the referral notation.

Hotline files reveal that youngsters who run out of state tend to end up, predictably, in Florida, California or New York. The populace mideast states,

Indiana and Ohio, log a high percentage of runaways across their borders, as do the states Pennsylvania and Virginia.

Some areas, notably Utah, Wyoming, northern Washington and some larger cities, are ill-equipped to handle what is, according to the FBI, the seventh most frequent cause of arrest in the U.S.

Most parents are similarly unprepared for that evening when they look in their son or daughter's room and find a note reading simply, "Goodbye." Nothing more.

In most states, a missing persons report cannot be filed until 24 to 48 hours have elapsed. Runaways tend to stay with friends the first night, so a tactful but thorough local search is the first step.

Checking the child's room may turn up phone numbers, newspaper clippings or other clues to a destination. If a contact is made through an agency or hotline, parents should take care to allow the child the distance and time he is asking for, and not issue unenforceable threats or orders scaring the child still farther away.

There is solace for parents knowing that 90 to 95 percent of all runaways eventually return home. Still, at any one time, thousands of American teenagers are on the streets, in flight from something or to something. The number seems to be growing.

Not the sensational news it once was, the runaway problem has quickly grown to epidemic proportions. As Cynthia Myers, director of the National Runaway Switchboard, says, "Running away is a commonplace thing now. It's no longer something parents whisper about."

Perhaps more important than all the government recognition of the problem is this simple realization among parents: their children are running away, and there has to be a reason why. ■

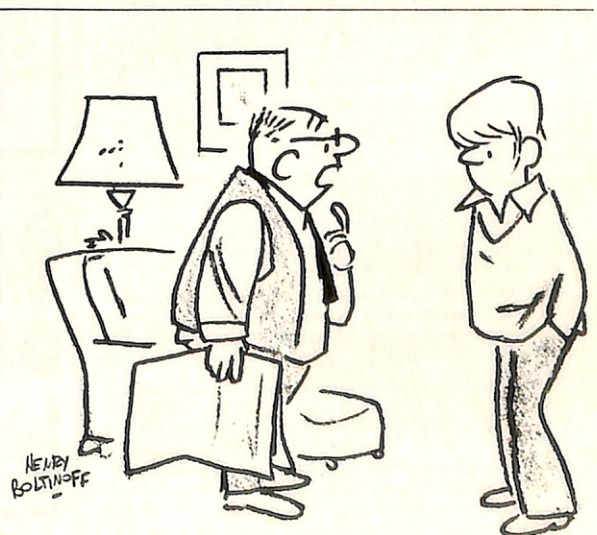

"When I was your age my father was boss of the house. Are you begrudging me my turn?"

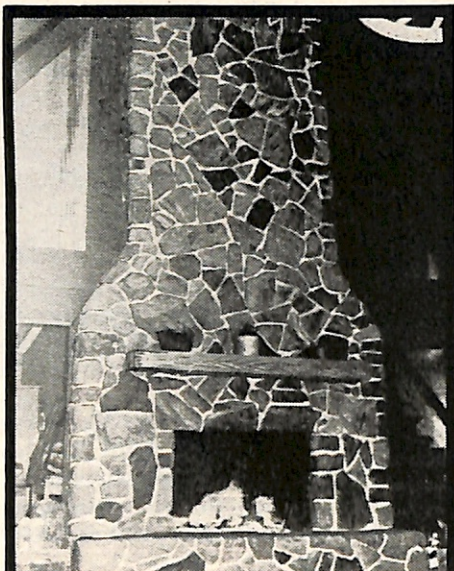

!!!MAKE YOUR OWN STONE!!!
!!!ANYONE CAN DO IT!!!
!!!SAVE THOUSANDS OF DOLLARS!!!
!!!LOOKS EXACTLY LIKE REAL STONE!!!

It's TRUE! The stone on the fireplace pictured above was made for less than \$50! AND, it LOOKS and FEELS so REAL it's unbelievable!!! I invented the process, and it's so SIMPLE, it amazes me why nobody has thought to try it before!!! You can make it in any color! Use it inside or out! Cover fireplace, wall, cookout, foundation! Make your own planters, cornerstones for driveways, THOUSANDS OF USES!!! **GUARANTEED 100%!!!** FREE BROCHURE.

Patent Applied for 1977 *© Darrell Wright 1977

STONE, Fox Bay Road, Dept. 0-3
Loris, S.C. 29569. Phone: (803) 756-8175
 Dealer Franchise Inquiries Invited.

Killer Putter!

Revolutionary New SIGHT-ALIGNMENT PUTTER: Makes Any Putt (Under 9 feet) A One-Putt Cinch! It's 100% guaranteed or your Money Back. Pick up easy bets as you sink Putt after Putt with deadly accuracy.

So Unique It Was Granted A U.S. Government Mechanical Design Patent; Its Special Cross-Hair Sight Alignment was researched and designed by touring PGA pro Brian Shillington. Correct Placement of your hands, head and feet becomes automatic. You read the greens, this exquisitely balanced Killer Putter by Duke with the Tacki-Mac Grip does the rest.

Play With It For 2 Weeks and Improve Your Putting Considerably. If not satisfied, Return it for Immediate Refund, no questions asked. \$24.95 ea. (plus \$2 shipping) Specify Men's or Ladies' putter. (Left Handed Model Also Avail.)

TO ORDER, CALL TOLL FREE 1-800-528-6050, ext. 1050. (Ariz. Residents Call Collect: 602-955-9710).

Or Send Check, Money Order, or Credit Card No. [BankAmericard/Visa, MasterCharge (include interbank #), American Express, Diners Club, Carte Blanche] and exp. date, CA Res. add 6% sales tax, plus your name and address to: Starshine Group, Dept. 396, 924 Anacapa St., Santa Barbara, Calif. 93101. Delivery will be made promptly.

ELKS FAMILY SHOPPER

More for your money

by Mike LeFan

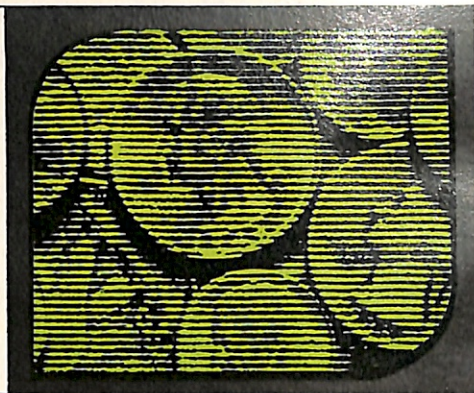

JULY BARGAINS

July bargains are nice—both the expected and the unexpected.

Household goods—save on furniture, refrigerators and freezers, and air conditioners. And believe it or not, July is a good time to get more for your money on fuel oil too.

Clothing—shop for savings on children's clothes, fabrics for sewing, sportswear, men's hats, and furs.

July sales to watch—check the 4th of July sales and the early summer clearances.

Food—Supermarket Snoop says there are seasonal savings (though all prices tend to be higher these days) on fresh beets, snap beans, cucumbers, and tomatoes. Watch for nice buys on fresh raspberries, blackberries, cantaloupes, cherries, nectarines, peaches, plums, limes, and watermelons.

"Dear Mike: A recent column had a request from a lady in Dyersburg, TN, asking where to sell coupons from magazines and newspapers. There's a newsletter for people with coupons to trade. Get subscription information from *Dollars Daily*, P.O. Box 348, Lakehurst, NJ 08733"—Dorothy Picasso, Brick Town, NJ.

Thanks, Dorothy. That should do the job nicely.

If you're installing air conditioning, the cost may be deductible on next year's income tax if your doctor prescribes it to relieve allergies. That's what the IRS says.

Want to know how to keep your home cool in summer and warm in winter without murdering your bankbook? Learn to save energy and money in the booklet *Energy & Your Home*. It's free from York Division of Borg Warner Corp., Dept. MM, P.O. Box 1592, York, PA 17405.

Looking for travel bargains? American Youth Hostels, Inc., can make travel more economical than you'd think, and their \$12 family membership is a golden pass to budget lodgings. Members can stay at over 200 U.S. hostels for \$2 or \$3 nightly. Accommodations are dormitory-style, most with kitchen facilities. Hostels are ideal for hiking, biking, or boating vacations. For information, write to Hostel Department, American Youth Hostels, Inc., Delaplaine, VA 22025.

Do you have a money saving vacation idea? Let me hear your experiences and I'll share the best ones here.

Vacations and taking pictures sort of go together. A used camera may be the economical way to upgrade your photo equipment. The best source for a used camera is a local dealer who probably has a good supply of cameras he got as trades on new equipment. Even with reputable dealers, it's best to get a written guarantee that the camera may be returned for full refund within a definite agreed-upon trial period. Camera departments in discount stores may have used cam-

SIDLES AUTO SUN SHADES



RIDE UP TO 15° COOLER with SIDLES SHADES
 Custom made from durable aluminum to block out the sun's rays. Easily installed and instantly removable. Increases air conditioner efficiency and saves passengers and contents from the ravages of a blazing sun. For free information send year, make, series, model (sedan, station wagon, pickup, bus, etc.), and style (2 or 4 door), with your name and address to: SIDLES MFG. CO., INC., Box 3537E, Temple, TX 76501. For questions and/or same day shipment on Master Charge/VISA/UPS COD phone orders, call TOLL FREE (800) 433-3101. In Texas call (817) 778-1636.

Stark Bro's Fruit Trees and Garden Catalog FREE!

Dwarf Fruit Trees, shade and nut trees, shrubs, berries, vines, bulbs, award-winning roses, and ornamentals.

Stark Bro's Nurseries & Orchards Co.
 Box A 15378
 Louisiana, Missouri 63353

Stark Bro's, Box A 15378, Louisiana, Mo. 63353
 Rush Color Catalog FREE!
 (Please Print)
 Mr _____
 Mrs _____
 Miss _____
 Address _____
 City _____
 State _____ Zip _____

eras, but you'll have a hard time getting any service or satisfaction if the camera proves defective. You may also hear of cameras for sale by individuals through newspaper classified ads or other sources, but the risk is great because you won't be able to get any kind of guarantee. Don't buy a mail order used camera unless you know the firm is reliable. Check their reputation with the Better Business Bureau in the city where they're located.

"Dear Mike: Two makers of tin canners are mentioned in the 1977 *Yearbook for Agriculture*. They are Ball Corp. and Dixie Canner Equipment Co. I'd appreciate an exchange of information with people interested in tin canning"—Dick Hunger, 1462 Peterson Rd., Burlington, WA 98233.

Okay, Dick, this should do it. Meanwhile, here are other sources of tin can canning equipment:

—Rowe Plastics and Die Casting Co., 2640 N. Southport Ave., Chicago, IL 60614 (the Ives-Way Can Sealer).

—Embarcadero Home Cannery, 2026 Livingston St., Oakland, CA 94606. Phone: 415-535-2311.

—Frank Duncan, Duncan Equipment Co., 506 Broadway, Seattle, WA 98108. He sells the Ives-Way canner. Tin cans are available from General Can Co., 6749 E. Marginal Way S., Seattle, WA 98108.

Thanks to Mrs. Fred Kaiser of Chicago, Robert Bell of Anchorage, Alaska, and an anonymous helper from Spain, WA, for those canner addresses.

"Dear Mike: We've just purchased a tin can canner from the Sears Summer Sale Catalog. Hope this is helpful"—Virginia Donaldson, Orland, CA.

Folks, this should settle the tin can canner business. So please, no more.

Get a free booklet of ideas to help if your car breaks down on the road. Order *Emergency Repairs*, Book No. 13 from Shell Answer Books, P.O. Box 61609, Houston, TX 77208.

Do you have rust stains on white washables? Apply a thick paste of salt, cream of tartar, and a little water to the stain. Place in the sun for 20

minutes and wash as usual.

Get your 1978 *Budget Motels List* with the facts on 37 motel chains offering cheap sleep, including many toll-free phone numbers for info and reservations. Send \$1 and a stamped, self-addressed, business-size envelope to Mike LeFan, Budget Motels Dept. EM, 1802 South 13, Temple, TX 76501.

Do you like fresh shrimp? Buy them by "count" rather than descriptive terms, which vary between retailers. One merchant's "Large" may be another's "Jumbo." Ordering by count lets you compare prices accurately and guarantees you'll get the desired size shrimp. Sizes range from 10 to 60 or more tails per pound (shell on). The larger the count, the smaller each shrimp, therefore the more work. Jumbos (15 count per pound) and Large (16 to 20 count) are best for frying or barbecuing. Mediums (26 to 35 count) are usually the best buy and are okay for most uses. Small shrimp (36 count or more) are great in gumbos, salads, and casseroles.

Send in your tip for "Money Saver of the Month" and get a prize if it's published.

Money Saver of the Month: "Don't discard leftover juices from canned pears, peaches, pineapple, or cherries," says Mrs. Catherine Brosnan of Woburn, MA, "Pour it in a half-gallon container in your refrigerator. It's surprising how much will accumulate. I use this mixed fruit flavor instead of water when making my own gelatin dessert. Add a few drops of food coloring to the unflavored gelatin with the fruit juices and you have a uniquely flavored dessert at a total cost of seven cents for five servings. Can also replace half the water in regular flavored gelatin." Thanks, Catherine. Folks, you're welcome.

Send questions and tips to Mike LeFan, c/o More For Your Money, 425 W. Diversey, Chicago, IL 60614. Because of the volume of mail received, individual replies cannot be made. ■

THE GOLDEN TOUCH



SHOWN 58% ACTUAL SIZE

World's Thinnest LED Electronic Timepiece ... only \$30

Back by Popular Demand

You don't have to be King Midas to have the "Golden Touch!"

Again we're offering the classic look of the "Golden Touch" at a very affordable price — a mere \$30.

Here is truly a timepiece fit for a king and queen. All you do is touch the golden dot on the watch crystal with your finger. Like magic the time or calendar functions appear in bright red digits.

The "Golden Touch" makes a great gift and is perfect as a second timepiece. The men's model is only 5.8mm thin. That's less than 1/4 of an inch! The ladies model is 8mm thin (approximately 1/4 of an inch). Both are available in elegant gold tone only and come with a one year warranty.

Latest Technology

The "Golden Touch" has no moving parts — nothing to wear out. Its quartz crystal controls accuracy to within 3 minutes per year. Batteries are easy to buy and last approximately 6-12 months. Its microminiature circuit controls 9 separate functions. They are:

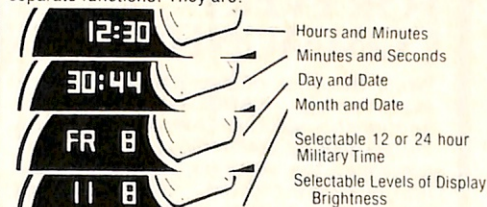

Why Shop By Mail?

Shopping by mail is convenient, easy, and fun. We ship all orders promptly to your home or office. You can charge your order to any major credit card. Most of our products are **not available** at your local store. And if that isn't enough, you have a 30 day no risk money back guarantee.

"Try any one of our products for 30 full days and if you are not happy with the performance, features, or for any reason wish to return a product, we will refund your full purchase price including the insured postage and handling charge!"

CREDIT CARD BUYERS: TO ORDER CALL TOLL FREE 24 HOURS A DAY

To order in California call collect (714) 540-4444

(800) 854-3831

DWS marketing international, 17875 Sky Park No., Suite G Irvine, California 92714

Call our toll free number for quickest service or send your check, money order or credit card info to us. We accept all major credit cards. Add \$2.50 for insured postage & handling for first product and \$1.00 for each additional product. California addresses add 6% sales tax. ©DWS marketing international 1978

LEARN TO PLAY

"PAN"

America's most exciting card game. Book of rules & how to win! Simple, Definitive, Illustrated. \$2.50 + 25¢ handling

Make check payable to

"PAN" BOOK

2010 Prairie Ave., Miami Beach, Fla. 33139

Name _____

Address _____

City _____ State _____ Zip _____

SPECIAL—F.C.C. REGISTERED—PART 68 MODERN TYPE DIAL PHONE

FOR PRIVATE LINE CUSTOMERS ONLY Party line cannot be registered

Complete with cards, dial ringer and modular end. (Pa. residents add Sales tax.) Can be charged to Master Charge or BAC/VISA.

BLACK . . . \$20.50 COLORED . . . \$24.50 GIVE STREET ADDRESS — SEND VIA UPS

Above prices include shipping and handling charges anywhere in continental U.S.A. If this ad is included with order. Send check or M.O. to

SURPLUS SAVING CENTER

Box 117, Dept. EFS-78, Waymart, PA 18472

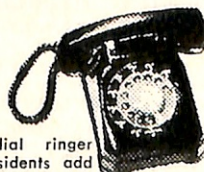

Sun Shield

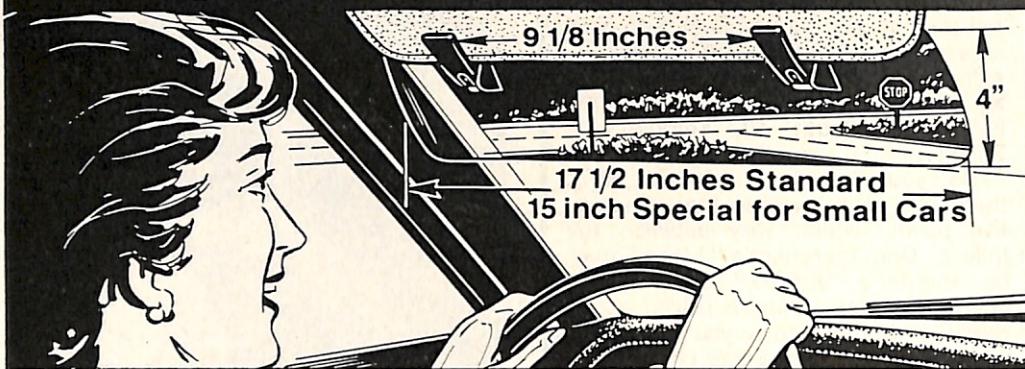

DOUBLES your driving COMFORT

- Reduces ALL GLARE and HEAT, front or side, Day or Night
- Accepted by leading safety authorities • Positive screw clamps hold securely
- Universally adjustable for look-through or shade-and-look-under.
- SATISFACTION GUARANTEED (Return within five days for full refund)

THE IDEAL GIFT • MOST ENJOYED • MOST APPRECIATED

Sun Shields, Inc. • 9179 General Court • Plymouth, MI 48170



- Check or money order enclosed; Michigan residents ONLY add 4% tax.
- \$5.00 for one Sun Shield, shipped postpaid promptly.
 - \$9.00 for 2 Sun Shields - Make your passenger comfortable, too!
 - \$42.00 Doz. (minimum, one order) for group buyers - fleet owners.

E Specify 15 in. LENGTH (not car model) for sub compact & small foreign cars.

Name _____ Street _____
City _____ State _____ Zip _____

NOW! BADGE-A-MINIT™. COMPLETE SYSTEM

BREAKS THE PRICE BARRIER... MAKE BUTTONS LIKE THESE FOR EVERY COMMUNITY USE

COMPLETE SYSTEM

\$19.95



While the cost of everything else is skyrocketing, BADGE-A-MINIT, Ltd. announces another breakthrough in badge-making technology. Now you can make the same high quality, colorful, plastic-protected, metal pin-back badges and buttons instantly for fairs, reunions, local events, school and club activities, elections, for business promotions or just for Fun for LESS than ever before! Discover "Badge Power": power to persuade, promote or create sympathy with your cause; let the guests at your next party "let it all hang out" with buttons that they make and wear upon arrival. Make one or one hundred — whenever the occasion calls for strong motivation. The button business can be a great side line for an enterprising son or daughter, too!

GET FREE SAMPLE BUTTON AND FULLY ILLUSTRATED DETAILS

The BADGE-A-MINIT system includes steel and fiberglass reinforced Lexan plastic hand die press, high impact color coded die set, 12 badge shells, 12 pin-back parts, 12 pastel perforated message discs, 12 plastic protective circular discs and colorful literature on all BADGE-A-MINIT, Ltd. accessories plus fully illustrated operating instructions.

BADGE-A-MINIT, Ltd., Dept. EL-78, Box 618, Civic Industrial Park, La Salle, Illinois 61301

Yes, send me a free sample button and fully illustrated details.

I'm convinced. Rush me the complete system. I've enclosed \$19.95 (check or money order) plus \$1.75 for postage and 5% sales tax for Illinois residents. Or use my credit card indicated below.

VISA (Bank Americard) Master Charge
 Diners Club American Express Carte Blanche

Credit Card # _____ Exp Date _____

Inter Bank # _____

NAME _____

ADDRESS _____

CITY _____ STATE _____ ZIP _____

SIGNATURE _____

UNCONDITIONAL MONEY BACK GUARANTEE

Elks Family Shopper

consumer/news

Going for a walk into the woods? Better know which plants are friends and which aren't. You'll especially want to watch out for poison ivy, oak and sumac. But, being out of the woods doesn't make you safe from poison ivy and oak. They can flourish in very dry soil on even the most exposed hillside. Heed the advice of the old saying "leaflets three, let it be," and you'll go a long way in avoiding the nuisance and discomfort these plants can deliver.

To help you recognize, avoid and eradicate these troublesome plants, the U. S. Department of Agriculture has an illustrated booklet, *Poison Ivy, Oak and Sumac*. For your copy send 35 cents to the Consumer Information Center, Dept. 046F, Pueblo, Colorado 81009.

Poison ivy and oak grow in three different forms: woody vines attached to trees or other objects for support, shrubs trailing mostly on the ground, and erect woody shrubs that stand without support.

They're most often abundant along old fence rows and edges of paths and roadways. They ramble over walls and climb trunks of trees. Often they grow within other shrubs or vines so you might overlook them.

Although leaf forms vary, there is one characteristic to watch for—the leaves almost always consist of three leaflets (although some harmless plants have this trait too,—

(Continued on page 42)

EASY-LIFT



LIKE A HELPING HAND.

Many people—senior citizens, arthritics, and those suffering from Multiple Sclerosis, Muscular Dystrophy or Parkinson's disease—need help getting in and out of a chair. The EASY-LIFT power cushion recliner gently lifts you forward as well as up to a semi-standing position. The lifting angle adjusts to fit your needs, controls are easy to reach, and it runs on household current. EASY-LIFT—like a helping hand.

WRITE FOR FREE BROCHURE AND NAME OF DEALER NEAREST YOU.
AMERICAN STAIR-GLIDE CORP.

4001 East 138th Street, Dept. EE-78
Grandview, Missouri 64030

Compare our prices on HIGH POTENCY VITAMINS AND SUPPLEMENTS FROM NUTRITION HEADQUARTERS



All prices POSTPAID! Satisfaction guaranteed or money back.

25 MCG.
**SELENIUM
TABLETS**
100 TABLETS **275**
500 for 10.00
1000 for 17.50

**VITAMIN
B6**
50 MG
TABLETS
100 TABLETS **95¢**
500 for 4.25

**GARLIC
& PARSLEY
TABLETS**
100 TABLETS **75¢**
500 for 3.25

**VITAMINS
FOR
HAIR
CARE**
Same Formula
Others sold for 9.95
50 DAY SUPPLY **\$3.95**

**BONE
MEAL
TABLETS**
100 TABLETS **49¢**
1000 for 3.95

Super Potency
500 MCG.
**VITAMIN
B12**
100 TABLETS **119**
500 for 4.25

DOLOMITE
Calcium
Rich
100 TABLETS **49¢**
500 for 1.85

10 MG.
**ZINC
TABLETS**
100 TABLETS **49¢**
1,000 for 4.45

"Formula
T-M"
Therapeutic
Multi-Vitamins
with Minerals
100 TABLETS **\$1.85**
500 for 8.99

**HERBAL
LAXATIVE**
100 TABLETS **95¢**
500 for 4.35

BIG 4
KELP, VIT. B6,
LECITHIN,
CIDER VINEGAR
100 TABLETS **98¢**
500 for 3.88

**19 GRAIN
LECITHIN
CAPSULES**
(1,200 mg.)
100 CAPSULES **1.59**
300 for 4.39

**RAISIN
NUT & SEED
Trail Mix
Natural Snack**
12 oz. **1.49**

**ONE GRAM
(1000 mg)
VITAMIN C**
With Rose Hips
100 TABLETS **1.49**
500 for 7.29

**FORMULA
S-6**
(Comparable to
"STRESSABS
600")
60 TABLETS **2.89**

**PAPAYA
PAPAIN
(Digestant)**
100 TABLETS **75¢**
500 for 3.25

100 mg VIT. C.
& Acerola in Each
Delicious Tablet
ACEROLA-C
100 TABLETS **98¢**
500 for 4.49

**ONE GRAM
DIET
PROTEIN
TABLETS**
Each contains 1
gram of protein.
240 TABLETS **4.95**
No carbohydrates
No fats

**BREWERS
YEAST
TABLETS**
250 TABLETS **65¢**
1,000 for 1.95

**LECITHIN
POWDER**
Dissolves Easily
8 oz. BOTTLE **1.49**

100 MG.
GINSENG
TABLET
50 TABLETS **99¢**
250 for 3.95

**ALFALFA
Tablets**
100 TABLETS **49¢**
500 for 1.95

Desiccated
LIVER
100 TABLETS **79¢**
500 for 3.49

**VITAMINS
A & D**
(5,000 A; 400 D)
100 TABLETS **49¢**
1,000 for 3.50

50 MG.
**VITAMIN B2
(RIBOFLAVIN)**
100 TABLETS **1.25**
500 for 5.50

BY MAIL POSTPAID
VITAMINE
400 UNIT CAPSULES
 50 DAY SUPPLY **88¢**
 100 FOR **\$1.49** 500 FOR **\$7.25** 1000 FOR **\$13.98**
Limit: One of Any Size to A Family
Mail Coupon with remittance to
NUTRITION HEADQUARTERS
104 West Jackson, N1802
Carbondale, Ill. 62901
© 1977 Nutrition Hqds.

500 MG.
**ASCORBIC
ACID**
VITAMIN C
100 TABLETS **95¢**
500 for 4.49

**WHEAT
GERM
RAW FLAKES**
1 lb. **59¢**
5 lbs. for 2.79

KELP
Tablets
(Iodine)
100 TABLETS **39¢**
1,000 for 2.49

**HI-POTENCY
STRESS
FORMULA**
(Same formula
as PLUS 72)
100 TABLETS **1.95**
250 for 3.89

**HERBAL
DIURETIC**
100 TABLETS **1.75**
500 for 6.50

**WHEAT GERM OIL
CAPSULES**
40 CAPSULES **1.10**
120 for 2.89

500 MG.
**BEE
POLLEN
TABLETS**
100 TABLETS **2.49**
500 for 9.85

**GARLIC
OIL CAPSULES**
100 CAPSULES **79¢**
500 for 3.75

**Multi-Minerals
9 VITAL
MINERALS**
100 TABLETS **98¢**
500 for 4.50

**Our "TOP-B"
B-COMPLEX "50"**
Famous Formula at a
Sensational Low Price!
Every Capsule Contains 50 mg.
B1, B2, B6, Niacinamide, Panto
Acid, Choline, Inositol; 50 mcg.
B12, Biotin; 50 mg. Paba; 100
mcg. Folic Acid.
50 Capsules **2.49** 100 Capsules **3.98**
250 for 9.49

83 MG.
**POTASSIUM
TABLETS**
100 TABLETS **1.25**
500 for 5.00

**ACIDOPHILUS
CAPSULES**
(Our Price)
100 CAPSULES **2.50**
250 for 4.95

**Fruit & Nut
CAROB
Candy Bars**
3 oz. **60¢**

**TIME
RELEASE
VITAMIN C**
500 MG. CAPSULES
100 CAPSULES **2.98**

**500 MG.
BRAN
TABLETS**
Easy way to get
this important
wheat fiber.
300 TABLETS **\$1**

**"SPECIAL
C-500"**
500 mg. Vit. C Plus
Rose Hips, 200 mg.
Bioflavonoids, 50
mg. Rutin, 25 mg.
Hesperidin
100 TABLETS **1.29**
500 for 6.15

**ORGANIC
IRON
Supreme**
100 TABLETS **1.49**
500 for 4.95

**DOLOMITE &
BONE MEAL**
100 TABLETS **69¢**
500 for 2.65

**VITAMIN
E
Beauty Cream**
1 oz. Jar **1.00**

**SUNFLOWER
SEED KERNELS**
12 oz. **89¢**
6 Pkgs. for 4.99

**"KITCHEN
FARM"
SEED
SPROUTER**
Make your own
bean sprouts.
Complete
Kit..... **1.00**

**PROTEIN
DIET
POWDER**
16 oz. CONTAINS 416
GRAMS OF PROTEIN
lb. **3.98**

**Money Saving
MAIL ORDER
BLANK** **RUSH
Your
Order
Now
to:** THE BEST TIME TO SAVE IS NOW!
NUTRITION HEADQUARTERS
104 West Jackson St. — N1802
Carbondale, Ill. 62901

List items you wish here:

QUAN- TITY	SIZE	NAME OF PRODUCT	TOTAL PRICE

**SATISFACTION
GUARANTEED** **WE PAY ALL
POSTAGE** **TOTAL—amount enclosed**

PRINT NAME _____
ADDRESS _____
CITY _____ STATE _____ © 1977 NUTRITION HQDS. ZIP _____

1000 RETURN ADDRESS LABELS \$1.00

1000 gummed economy name and address labels printed in black with ANY name, address, zip code. Up to 4 lines.
Order S717 Set of 1000 Economy Labels (boxed) . . \$1.00

FREE HANDY BOX

Mrs. Frederick D. Johnson
221 S. 23rd Street
West Highland Park
Anytown, Kansas 80940

250 Self-Stick GOLD FOIL LABELS \$1.98

GLEAMING GOLD FOIL

Gleaming gold foil labels stick to any clean, dry surface—need no moistening. Rich black printing, classic border.
Order P6128 Set of 250 Gold Foil Labels (boxed) . \$1.98

The John Smith
Music Eaters
4420 East Platte Ave.
Anytown, Colorado 80940

250 Self-Stick WHITE GLOSS LABELS \$1.98

STICKS AT A TOUCH

Glossy white self-stick labels cling to any smooth surface—no moistening. Sharp black printing up to 4 lines.
Order P6030 Set of 250 White Gloss Labels (boxed) \$1.98

Mrs. Frank Meyer
1156 Parkway Blvd.
Academy Vista
Anytown, Colo. 80940

Walter Drake 3297 Drake Bldg. Colorado Springs, CO 80940

NAME _____
ADDRESS _____
CITY & STATE _____ ZIP _____

___ S717 1000 Labels @ \$1 each \$ _____
___ P6128 Gold Foil Labels @ \$1.98 each \$ _____
___ P6030 White Gloss Labels @ \$1.98 ea \$ _____

Add 20¢ per set for postage & handling \$ _____
SATISFACTION GUARANTEED Total \$ _____

VICTORIAN 3-D VIEWER SETS

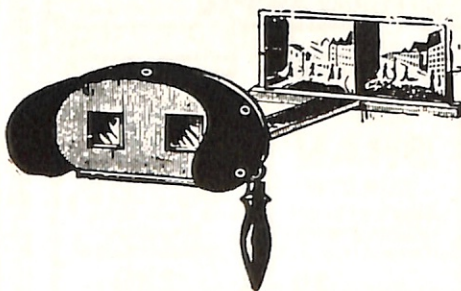

Invented in 1859 by Oliver Wendell Holmes, our hand crafted stereoscope is a handsome reproduction of his famous instrument. It is superbly made of solid wood, with a rich walnut finish. All fittings and hardware are solid brass. The brass hood is silk screened with a special design and edged in crushed velvet. The Holmes Stereoscope makes a decorative addition to any home.

This Victorian Masterpiece is your window on the past. You, your family and guests will enjoy 62 3-D pictures taken between 1859 and 1920. See gold miners on the Chilkoot Pass, visit the Paris World's Fair, Times Square in 1859, see the Cardif Giant, the San Francisco earthquake, Buffalo Bill, peek at Victorian risque, and MUCH, MUCH MORE!

Included in your set you get:

1. The Hand-crafted Stereoscope
2. 62 old-time 3-D views and
3. The booklet "The Story of the Stereoscope" all for one price: \$19.95, (+ \$1.50 pstg. & hdg.) add applicable sales tax.

YOU LOVE IT OR YOUR MONEY BACK!

P.S. If you already have a stereoscope, the 62 views and the booklet alone are only \$6.95 (+ \$1.00 pstg. & hdg.).

STEREO CLASSICS
P.O. Box 92-53, Sparta, New Jersey 07871

We buy old stereoscopes, views, and cameras. Restoration parts available.



Cheney. Because Frank really enjoyed his game room.

Frank built his own game room and enjoyed many hours there. But then he was confined to a wheelchair and was unable to use it. Now his Cheney Wheelchair Lift III makes movement up and down the narrow basement stairway safe and easy. For more information on Cheney Wheelchair Lifts, Wheelchair Van Lifts, and Wecolator™ stairway elevators, contact your Cheney Representative, or write: The Cheney Company, Dept. EM, 3015 S. 163rd St., New Berlin, WI 53151 (414) 782-1100.

helping people help themselves
CHENEY Wheelchair Lifts

THE CONTINENTAL FACTORY SPECIAL

\$299.95
Compare at \$499.95
And Save \$\$\$

7 H.P.



New 1978 models
One full year warranty.

RIDING MOWER

MANUFACTURER TO YOU

Over 3,000 Big, Powerful 7 H.P. Briggs & Stratton Mark VII Riders, featuring a bigger cut. Fully assembled in crates, delivered free. Dozier blade & grass catcher available. We are not a Mfg. Sales Co. selling other Co's. products, we are the manufacturer. Order now or send for free brochure while they last! Write

CONTINENTAL MFG. DEPT. E
3205 E. Abrams St.-Arlington, Tx 76010
Phone: 817-640-1198

HANDWOVEN HUARACHES



\$12.90 plus \$1.75 P & H

Open toes and heel for comfort and fashion. Supple genuine steerhide Leather crafted into a sturdy shoe. Imported for us in NATURAL. Full sizes: 5-10 M.

OLD PUEBLO TRADERS
Dept. E7R
600 S. Country Club, Tucson, AZ 85716
Send \$1 for our latest Fashion Catalogue (refundable with first purchase).

Elks Family Shopper
consumer/news

seeing this pattern will at least caution you.)

Poison sumac grows as a coarse woody shrub or small tree, and never in the vinelike form of its poison ivy relatives.

It doesn't take much of the poisonous substance to give you trouble. A small amount can cause severe inflammation of the skin. The poison is easily transferred from one object to another. For instance, clothing may become contaminated and is often a source of prolonged infection. Don't wear contaminated clothing until it is thoroughly washed. And don't wash it with other clothes. Another source of contamination may be the family pet. Dogs and cats may brush against the plants and carry the poison to children or other unsuspecting folks. The poison can remain on the fur of animals for a considerable time after they've walked or run through poison ivy plants. Animals can be decontaminated by bathing, but be careful to avoid poisoning while you're washing them.

And keep in mind that smoke from burning plants carries the toxin and can cause severe cases of poisoning.

For families planning a trip abroad this year, the Health Insurance Institute offers the following sound advice:

- ✓ Should you become ill or injured and are uncertain about local medical standards, always contact the nearest U.S. Embassy or Consulate for help.
 - ✓ Remember that if you require medical services, you will normally have to pay the bills locally. For this reason, get all your bills in duplicate. A copy should be sent to your insurance company on your arrival home.
 - ✓ Most health insurance policies
- (Continued on page 44)

See Advertisement on Inside Front Cover

Satisfaction Guaranteed! Mail Coupon Today
OLD VILLAGE SHOP, DEPT. M-3546
340 Poplar Street, Hanover, Pa. 17331

Please rush _____ prs. of the genuine Leather "Ranchero" Dress Boot (M246470F) for the low price of just \$19.95 pr. plus \$1.75 postage and handling on full money back guarantee.

SAVE MORE! Order two pairs for just \$38.00 plus \$3.25 postage and handling on same money-back guarantee.

___ prs. Cordovan Brown (M246470B) size _____ width _____
___ prs. Black (M236356B) size _____ width _____

CHARGE IT:

American Express Carte Blanche
 BankAmericard/Visa Diners' Club
 Master Charge Interbank # _____

Acc't # _____ Exp. Date _____

C.O.D. (Enclose \$2 deposit per pair)
Enclosed is \$ _____

Print Name _____
Address _____
City _____
State _____ Zip _____

FREE
Golf Glove

With the **SECRET GRIP**

wide Velcro™ fastener for best fit possible. Satisfaction guaranteed or your money back. Buy One Master Touch Glove @ \$6.95 and get one FREE!!! Add \$1 total for handling and postage. Limit: 6 gloves @ 6.95 each.

Choice of: White Lt. Blue Red

Number of gloves to be worn on Right Hand

MEN'S **LADIES'**

Long-Life — Perfect Fit Has "Breathing" Qualities

ONE SIZE FITS ALL

Send coupon with check or money order to:

Carol Sport's Ltd.
Box 308, Santa Ynez, Calif. 93460

Mention This Ball And Golf Hustlers Clam Up!

Core out-rebounds any other by up to 51%.

High-tension winding bonded both to cover and core.

Lifetime Cut-Proof Cover. No more "smilers"

Extreme compression and perfect roundness locked in for life!

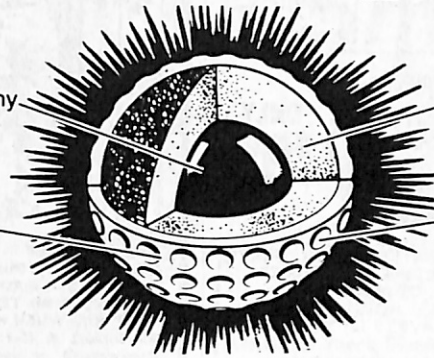

It drives 20-30 yards longer. Puts like a billiard ball. Straightens out hooks & slices. Trims 3 to 5 strokes off your score! Guaranteed! To prove it we'll send 1 ball FREE. (Be convinced or don't pay!)

**GOLFING!
FISHING!
BOATING!
TENNIS!**



Show your pride in the Elks! Wear a summer cap with the Elks emblem.

Order now for summer! Buy one for you and your friends. Adjustable head sizes and fully washable. Your choice of cool comfortable nylon mesh combination or lightweight texturized knit.

Knit \$5.50 -:- Mesh \$5.00

Colors available: Lt. Blue, Yellow, Tan, Lm. Green, Red, Royal & Black, Lt. Blue, Matze, Red, Black, Green Orange.

Send name, address & quantity desired with check or money order to:

BRONSON DISTRIBUTING

1556 E. 6600 S., Rt. 4 -:- Ogden, Utah 84403

Include 50¢ for shipping & handling.

Allow 4 - 6 weeks for delivery.

Money back guarantee.

Buy 12 or more & get your lodge number included.

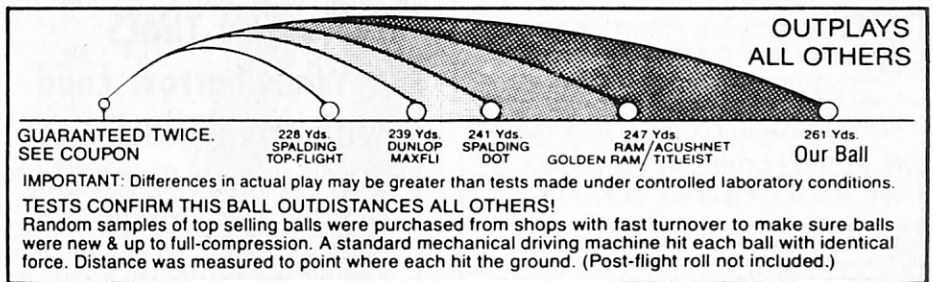

WARNING: Illegal for USGA Tournament Play!

By regulation, no U.S.G.A. approved ball can come off the clubhead at a velocity of more than 250 feet a second. But our golf ball can, and does! So, they made it illegal in the U.S. Our ball comes off the clubhead faster! It travels farther with more roll and less bounce!

On the green it putts like a dream and is so deadly in money play that one top tournament pro commented, "They'd have to make every course in America 2,000 yards longer if this ball was ever legalized." (You know who he is, but if we used his name in this ad he'd sue our pants off.)

How it Works

Our golf ball is smaller in circumference, yet weighs the same as the American ball. This means it has greater density, and higher compression packed into a smaller area. So, it comes off the clubhead like a cannon shot, with a flatter, lower trajectory. It handles better in wind, goes straighter and 30 yards farther! What's more, it cuts down on hooks and slices be-

cause, its smaller size makes more contact with the clubhead's "sweet spot"! No wonder the same pro states point-blank, "any time you have the choice, it's silly to play the big ball."

Like Putting Into a Barrel!

Our ball drives at least one club longer. You will hit one club less on short irons. On long par 5's, reach the green in 3 (or even 2 if you're already a long hitter). You'll birdie shorter par 4's. Even duffers will find themselves shanking fewer shots, because you can actually hit this ball off-center and it'll still go straight! On the green, it putts like a billiard ball, so you'll sink more short putts and leave long-putts closer to the hole. Our golf ball starts off faster and runs truer, and you worry less about the way the putt will break! Furthermore, because the ball-to-cup ratio is changed dramatically in your eyes, you'll feel like you're putting into the mouth of an open barrel!

With all this going for you, if you don't cut at least 3 to 5 strokes off your score, you aren't really trying!

PROSTATE

Amazing formula has helped thousands get rid of prostate pain and distress. End problems such as pain, dribbling, urgency, retention and getting up nights. Write today for...

FREE REPORT
Rush free report on prostate relief.

Name _____ Age _____

Address _____

City _____ St _____ Zip _____

Proscos, Dept. EK7
Box 5644, Santa Monica, Calif. 90405

Golf Balls, DEPT.GHB-1, 49 Riverside Ave., Westport, CT 06880 American Express

Gentlemen: Please send me the following packages of Greenhornet Golf Balls. Carte Blanche Diner's Club

Or, Charge: Master Charge BankAmericard

(Min. Charge: \$10 plus postage, handling)

How Many? _____ Dozen(s) for \$16 PLUS 1 FREE (Add \$1.50 Delivery)

Card No. _____

Still not convinced? Try 3 for \$5.50 (add 50¢ delivery)

Expire Date _____ Master Charge Bank No. _____

I understand I may play these balls entirely at YOUR risk. I must be 100% delighted, or I may return them within 30 days for full refund of the entire purchase price. The free ball is mine to keep.

Signature _____

I further understand that every ball is covered by a LIFETIME GUARANTEE of FREE replacement should it ever cut, go out-of-round or lose its built-in perfect balance.

PRINT NAME _____

CHECK OR MONEY ORDER ENC. for \$ _____

ADDRESS _____

(CT residents add sales tax.)

CITY _____ STATE _____ ZIP _____

©The John Sturges House, Inc., 1978

NOW! LIFT A TON WITH ONE HAND

WITH AMAZING 1-LB. POCKET HOIST!

Picture your car stuck in a ditch. You pull out this little brute, attach to the nearest tree, pull the nylon cord with one hand and ZAP! You pull that car out of the ditch without raising a sweat!

This powerful multiplying ratio block-and-tackle that fits in the pocket of your hunting jacket and weighs less than a pound, will make you as strong as 7 men!

With it, you can hoist a 250-pound deer easy as lifting a child. Lift a ton of freight. Haul the engine from your car. Move huge rocks. You name it. Complete with 65-ft. nylon rope, and

aluminum and stainless steel block-and-tackle.

30-DAY MONEY-BACK GUARANTEE—ORDER TODAY!

The JOHN STURGES HOUSE, Inc. Dept. THA-20

49 Riverside Ave., Westport, CT 06880

Please rush POCKET HOIST(S) @ \$9.95

ea. Add \$1. ship. & hdlg. SAVE! 2 for \$18.95 ppd.

Sorry, no C.O.D.'s. I enclose check money

order for \$..... (Please add applicable sales tax.)

OR, CHARGE: BankAmericard/Visa

Master Charge Carte Blanche

Diner's Club American Express

Interbank #..... Exp. Date

Card No.

PRINT Name

Address

City

State Zip

© The John Sturges House, Inc., 1978



Clear a field of tree stumps.



Load or unload your boat trailer.



Lift a King-size deer for dressing.



up to 2000lbs

ONLY \$9.95

TEE-LINER

GOLFERS: CUT STROKES FROM YOUR GAME
ELIMINATE GUESS WORK IN LINING UP
LEARN TO DRIVE STRAIGHT, SLICE OR HOOK
WHEN YOU WANT TO.
STAY OUT OF THE ROUGH.

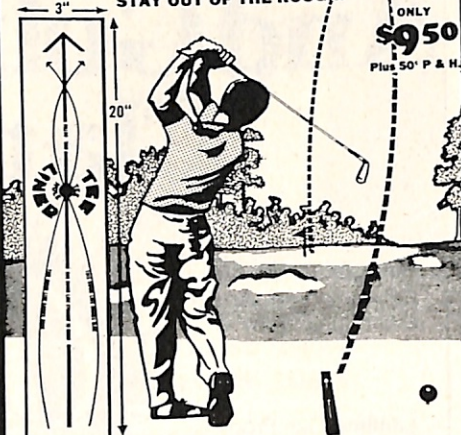

ONLY \$9.50
Plus 50¢ P & H.

THE TEE-LINER — A NEW SECRET WEAPON TO USE AGAINST YOUR GOLFING BUDDIES — GREAT FOR GIFTS — MADE OF SOFT DURABLE RUBBER LAYS FLAT ON TEE — ROLLS UP TO STORE IN GOLF BAG WHEN NOT IN USE.

All Gilbert & Barton Products are Satisfaction Guaranteed or your money promptly refunded.

SEND TODAY \$9.50 plus 50¢ P & H TO...
GILBERT & BARTON INC., DEPT 17B BOX 11314
6513 E. MISSION, SPOKANE, WA 99206

Carry TEN TIMES a Wheelbarrow Load with INCREDIBLE EASE!

These BIG, strong carts are perfectly balanced on two huge wheels — roll easily over lawns and gardens — carry up to 400 lbs. of load — huge volume capacity means you make fewer trips — you'll save time and steps.

If you are still struggling with a wheelbarrow or inadequate cart (with tiny wheels) send for FREE Cart Catalog. Build-it-yourself kits, too.

GARDEN WAY RESEARCH, Dept. 80127
Charlotte, Vermont
05445



Fast, Efficient, Reliable COMPOST BINS

Turn garden and kitchen wastes into rich, fertile compost to improve poor soil and feed your plants. Grow bountiful harvests of vegetables and more beautiful flowers. Scientifically designed bins produce valuable compost in weeks. No turning the heap. Make a ton in one season. Send for FREE catalog:

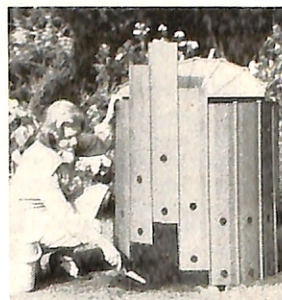

ROTOCROP

142 Aero Park PATENT 3951294
Doylestown, PA 18901

Elks Family Shopper

consumer/news

will cover you for illness or injury anywhere in the world.

➤ If you would like to add to your insurance during the time you are abroad, it's available through low-premium, short-term "special risk" policies. These standard trip policies are usually in force for from one to 180 days with benefits primarily for accidents, but they sometimes cover some of the costs of illness, too.

Carcinogen has become a word we see too often. It means something that causes cancer. But, there's one carcinogen that will never be banned, because without it we'd have no life. And that carcinogen is the sun. The ultraviolet radiation from the sun is the leading cause of skin cancer.

Many people don't realize that skin cancer is a significant health threat. The Food and Drug Administration has reprinted an article from its magazine the *FDA Consumer* that explains the dangers. For your free copy of *Sunbathing and Skin Cancer*, send a postcard to the Consumer Information Center, Dept. 582F, Pueblo, Colorado 81009.

Skin cancer is the most common form of cancer. There are 300,000 cases a year, and more than 6500 deaths. But, just about every skin cancer death is avoidable. Skin cancer, because you can see it, can almost always be detected and treated.

(Continued on page 45)

TRY A BURKE ELEVATING CHAIR FREE FOR A WEEK.

The Burke Chair helps you all the way to a standing position—safely and gently. Send for a free catalog. Then, if you desire, select the recliner, rocker or contemporary of your choice. And try it free for a week in your own home.

ASK ABOUT MEDICARE COVERAGE!

BURKE!

P.O. Box 1064, Dept. E-778
Mission, Kansas 66202

CALL TOLL-FREE

1-800-255-4147



KNITTING WORLD



● For those who LOVE TO KNIT! Over 100 exciting knitting patterns during the year!

● KNITTING PATTERNS, PHOTOS, EXCHANGES, CONTESTS, FEATURES,

DESIGNS, ARTICLES, ETC., ETC. - Truly a Great Big Knitting World! (Pub. Bimonthly)

JUST \$3.50 Per Year

KNITTING WORLD

Box 337-C, Seabrook, N.H. 03874

Elks Family Shopper consumer/news

ed at an early stage.

The most common skin cancers, which rarely result in death, are called basal and squamous. Basal cancers are characterized by pale, waxy, pearly nodules or by red scaly, sharply outlined patches. Squamous cell cancers appear as scaly patches and nodules. Eventually the nodules of either type may ulcerate and form crusts.

Melanoma, the third important type of skin cancer, is much less common but far more dangerous. Melanomas usually are dark brown or black (although there are some without pigmentation.) They occur usually as mole-like growths, initially small but increasing in size. Many arise from moles. They may ulcerate and often bleed easily when slightly injured.

Any skin changes should be called to a physician's attention. Skin cancers can be treated successfully in several ways. They can be removed surgically, eliminated by heat or freezing, or treated by X-ray. Active chemicals also may be applied directly to the tumor as ointments or solutions. Sometimes a combination of methods is used.

The ultraviolet light of the sun is invisible, so you can't feel it at the time of exposure. Its after effects however, can include eye injury, sunburn, and a variety of skin eruptions, premature aging of the skin, and skin cancer. Excessive heat from the sun can cause illness and in rare instances, death by sunstroke.

Most dermatologists consider excessive sunbathing foolhardy. To the argument that the sun stimulates the production of vitamin D on the skin, the experts reply that you can get all the vitamin D you need from a proper diet. To the contention that the use of sunscreen lotions will promote a tan
(Continued on page 46)

If you're into fitness, Bullworker® puts it all together in only 5 minutes a day:

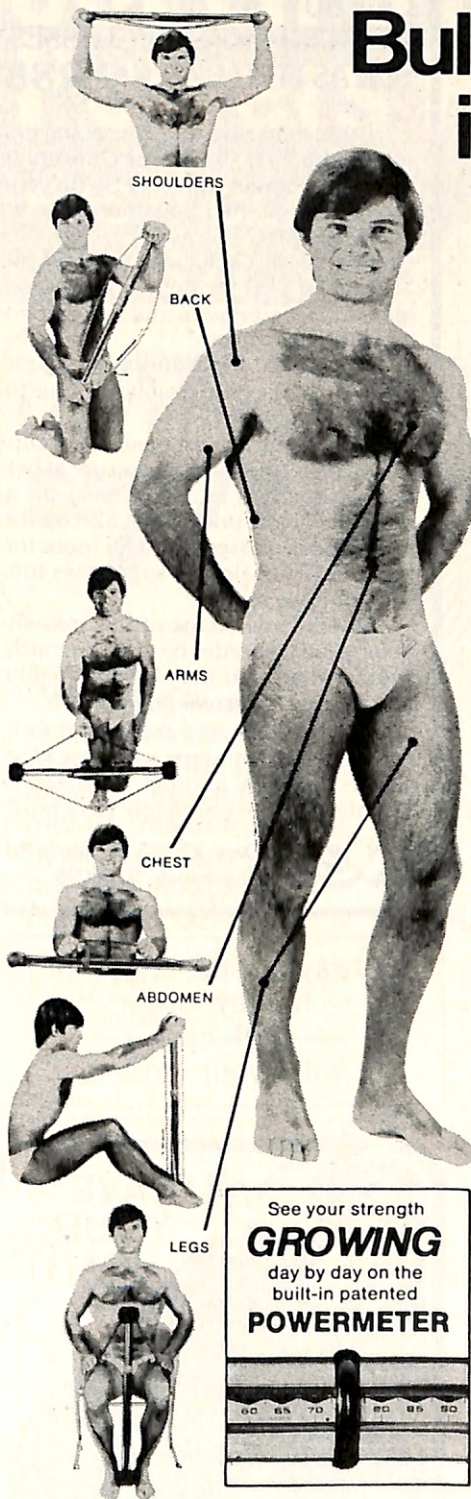

"Looking for a fitness program that's fast, easy and gets results right away?," asks fitness expert, Bob Breton. "Bullworker puts it all together. In just 5 minutes a day you can give your body a complete fitness workout: shoulders, back, arms, chest, abdomen and legs.

It's fast: each exercise takes only 7 seconds, once a day.

It's easy: any man between 15 and 65 in good general health can run through the whole program without getting tired.

You can see your progress right from the very first day on the built-in Powermeter gauge. After two to three weeks of training, most men can expect to measure an extra inch or two of muscles on their shoulders, chest and biceps—and an inch or two less flab around the middle.

And that's just the start: there are specialized exercises for building-up or trimming down any part of your body you want to. What's more, since Bullworker training is progressive, you perform better each time. Yet the training always seems easy since with every workout your strength increases by about 1%—that's an increase of up to 50% in the first three months.

"I earn my living by keeping executives in top shape," says Bob. "My customers want results and they want them fast. I recommend Bullworker for one reason only: because it's the most advanced fitness trainer on the market and you better believe it."

To receive complete details about Bullworker Fitness training, mail coupon for FREE BOOKLET today. No obligation, no salesman will visit.

See your strength
GROWING
day by day on the
built-in patented
POWERMETER

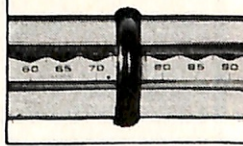

© BULLWORKER SERVICE, 201 Lincoln Blvd.
P.O. Box X, Middlesex, N.J. 08846

263

See Advertisement on Back Cover

Haband's 100% Polyester Knit
NO IRON KNIT SLACKS

2 PAIRS FOR 1795 While They Last

3 for 26.75 4 for 35.50

HABAND COMPANY Direct Service Dept. 72L-063

265 N 9th St., Paterson, NJ 07530

Gentlemen: Please send me _____ pairs of these slacks, for which I enclose my full remittance of \$_____.

COLOR	What Waist	What Inseam
Light BLUE		
TAN		
NAVY		
Dark GREEN		
Dark BROWN		

AVAILABLE IN SIZES:
Waists 29-30-31-32-33-34-35-36
37-38-39-40-41-42-43-44
45-46-47-48-49-50-51-52-53-54
Inseams 26-27-28-29-30-31-32-33-34

Name _____
Street _____ Apt. No. _____
City _____
State _____ Zip Code _____

FREE BOOKLET



24 pages of action photos in full color show you how to build a powerful body in just five minutes a day

BULLWORKER SERVICE, Dept. BW3310
201 Lincoln Blvd., P.O. Box X, Middlesex, N.J. 08846

Please send me my FREE full color brochure about BULLWORKER without obligation. No salesman will visit.

Name _____ Age _____
please print

Street _____ Apt. No. _____

City _____

State _____ Zip _____

Canada Home delivery duty paid Ask for FREE booklet

CHARCO-QUIK STARTER

5 MINUTE CHARCOAL STARTER

No more dangerous fluid... no more "oily" taste.



Two sheets of crumpled newspaper are all you need to start your charcoal. Heavy duty all-metal construction.

Enclosed is \$6.95 (check or M.O.) plus \$1.50 postage and handling. Wisconsin residents add 4% sales tax. **CHARCO-QUIK, INC.** Box 166E, Pewaukee, WI 53072

name _____
address _____
city _____ state _____ zip _____

SAVE UP TO **\$171.60**

on a famous **TROY-BILT Tiller!**

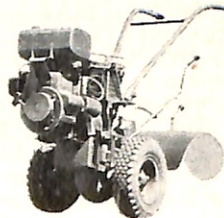

Just **ONE HAND!**

"Off Season Savings" now in effect! Right now is the best time ever to learn about the amazing TROY-BILT Roto Tiller-Power Composter... the "breakthrough" machine that's allowing anyone—of any age—with any soil—to easily have a fabulously fertile, productive garden! For free complete details, prices, write today to: **TROY-BILT Tillers, Dept. 80557** 102nd St. & 9th Ave., Troy, NY 12180.

ELIMINATE PAINFUL Eyeglass Irritation

with **ZYLONS**

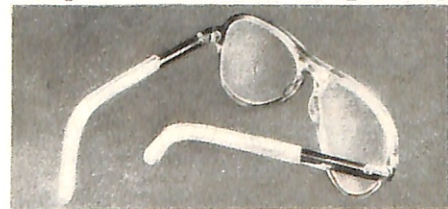

Eyeglass pressure on your ears... until Zylons all you could do was take your glasses off! Now soft Zylon temple covers can cushion your earpieces. Just put them over the backs of plastic or metal frames—and no more pressure. That's a guarantee! Long wearing and invisible—frame colors show through. Instant comfort for only \$1.00 per pair. \$2.33 for 3 pairs, or \$3.33 for 5 pairs. All orders include postage. FREE catalog with order.

DORSAY, 240 Kinderkamack Rd. Dept. ZY18A, P.O. Box 203, Oradell, N.J. 07649

NOW YOU CAN BUY PRESCRIPTION EYEGLASSES FOR AS LITTLE AS \$28.88

If you think you've been paying too much, the FTC Bureau of Consumer Protection agrees with you! So do very many distinguished Senators and consumer experts.

You've probably been paying \$50, \$60, even \$90 for your prescription glasses. *Because you couldn't find an ad with lower prices!*

Now NES, the National Eyeglass Service, makes it possible for you to shop... and save!

NES offers highest quality prescription glasses (the same as you get at better optometrists and opticians) for a remarkably low price. Only \$28.88 for single focus glasses. Only \$5 more for bifocals. Trifocals and sunglasses too, at enormous savings!

To take advantage of this tremendous value you order by mail. It's much simpler than you may think. Quality and fit are *absolutely guaranteed*.

Just write us and we'll send you complete information on these fine glasses and how to order them easily. No salesman, no obligation. Do it now!

NES Dept. 27, 773 St. John's Rd. Woodstock, IL 60098

Always send check or money order —not cash— with your orders



"SAVE YOUR HEART"

with a **STAIR-GLIDE** Stairway Elevator

RENTAL-PURCHASE Program Available

Your STAIR-GLIDE® installs easily and in less than 2 hours. No marring walls or stairway. No special wiring required. Shipped directly from factory within 4 days. STAIR-GLIDE... the nation's largest selling stairway elevator! UL LISTED.

USED BY THOUSANDS: CARDIAC PATIENTS, ARTHRITIS, SENIOR CITIZENS, PHYSICALLY RESTRICTED, POST OPERATIVES...and household convenience.

WRITE FOR FREE BROCHURE AND NAME OF DEALER NEAREST YOU.

AMERICAN STAIR-GLIDE® CORP.

4001 East 138TH ST., Dept. E-78 Grandview, Missouri 64030

Elks Family Shopper consumer/news

without burning, the experts say that a tanned skin is a damaged skin. Besides, whether you burn or tan, there's always a chance that ultraviolet radiation will initiate the cancer formation process.

About 60 percent of the ultraviolet rays of the sun reach the earth's surface between 10 a.m. and 2 p.m. So, you can reduce the risk of potentially damaging radiation by not sunbathing between 10 a.m. and 2 p.m.

If you're a sunlamp user, you need to be careful too. Many sunlamps produce ultraviolet radiation that, like the rays from the sun, can cause eye injuries, skin burns, and possibly, even cancer.

Remember reading about the good ole days when you could **homestead on public lands?** A lot of people would still like to get free or cheap land from the federal government and wonder how they can go about doing it.

To help answer consumer questions about land owned by the fed- (Continued on page 47)

PET ODORS & STAINS Removed Forever!

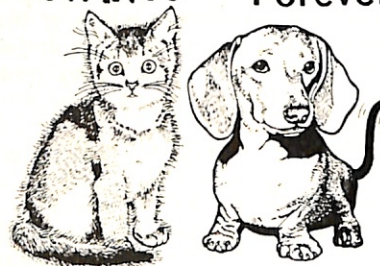

Stains and odors caused by pet accidents, even urine, removed **completely and permanently** from your carpet. RESCUE KIT contains two 8-oz. scientific sprays (non aerosol) for all stain or odor problems: carpets, upholstery, litter boxes, etc. Specify "A" kit for stains; "B" kit for odors; or "A" & "B" mixed kit. **Must work safely and completely or your money back.** Send Ck. or M.O. 1 kit \$6.50 + \$1 post. Save \$2: Order 2 kits for \$12.99 (and we pay post.) Immediate Shipment.

American Century

135 So. La Brea, Dept. 6078 Box 36277, Los Angeles, Calif. 90036.

Model shown: 12 foot Pearl Mist® \$369.95



GREENHOUSES

Send today for my FREE fact filled, informative COLOR CATALOG. Full size, quality REDWOOD home greenhouses.

FREESTANDING MODELS, **\$134.95** LEAN-TO AND DOMES! From

Peter Reimuller THE GREENHOUSEMAN® 980 17th Ave. Dept. 12-G Santa Cruz, Ca. 95062

Elks Family Shopper

consumer/news

eral government, the U.S. Department of the Interior's Bureau of Land Management has published a new pamphlet, *Can I Really Get Free or Cheap Public Land?* For a free copy of this publication, send a postcard to the Consumer Information Center, Dept. 678F, Pueblo, Colorado 81009.

Despite advertisements you may see in magazines or newspapers, the blunt truth is that the days of homesteading are over. According to the U.S. Department of the Interior, by 1976, Americans had been granted or sold 287,500,000 acres of public land under the Homestead Act of 1862. This Act has been repealed for all states except Alaska.

The Homestead Act will continue in Alaska until 1986, but not until after the land has been divided among Alaskan Natives, the state, and various Federal agencies. So, it will be several years before any land opens up.

Occasionally, public lands are sold; but, in 1976, only 3,641 acres were sold in 79 public auctions. And, the land is not cheap. No public land is sold for less than fair market value, and often, it's more than comparable private land.

If you're interested in public lands in a particular state, you'll need to write to the State Office of the Bureau of Land Management, U.S. Department of the Interior. The addresses are listed by state in the free pamphlet.

KILL!

NOW RID STABLES, TACK ROOMS, GARDENS, FARMS, Etc. of this dangerous nuisance..

FLY-GONE

is the proven fly killer. Traps and holds flies in standard quart jars. Place in strategic animal areas. Guaranteed — lasts for years.



(Jar not incl.)

No chemicals!

\$3.99

Add 50¢ for postage and handling.

Calif. residents add 6% sales tax

SPECIAL!

Order by the case of 12 and SAVE! \$43.00 case plus \$2.00 Shipping charges. Calif. residents add 6% sales tax.

MAIL ORDER ONLY! ORDER TODAY!

FLY-GONE DISTRIBUTING CO.

14801 Keswick, Van Nuys, CA 91405

SUPER STRIPPER™ Powers Paint Off

FAST! CLEAN! EASY!

NEW LOW PRICE \$7.77

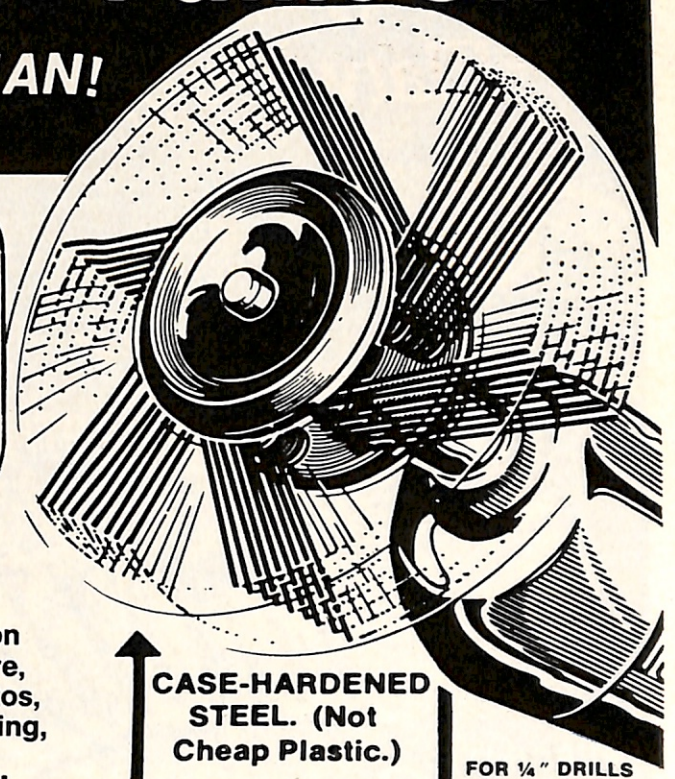

"Whipping Action" does hundreds of big and little jobs on all surfaces—furniture, metals, masonry, autos, boats—without sanding, burning, scraping or harmful chemicals!

CASE-HARDENED STEEL. (Not Cheap Plastic.)

FOR 1/4" DRILLS

Amazing price break lets you buy Super Stripper for far less than ever before! Never buy expensive, dangerous paint removers again.

Works on a new principle (30 flexible carbon alloy steel fingers produce up to 75,000 stripping strokes a minute) to do the job cheaper, safer and last a lifetime. Made of solid steel. High-speed "whipping action" makes paint, rust, scale vanish as if by magic! SAFE TO FINE FURNITURE when used as directed. Leaves a satin smooth finish, ready for paint or stain. No sanding needed (won't raise wood grain as liquids do).

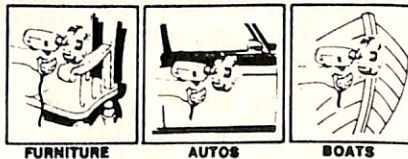

FURNITURE

AUTOS

BOATS

The Professional Partner for your Super Stripper! NEW! SOFT GOGGLES

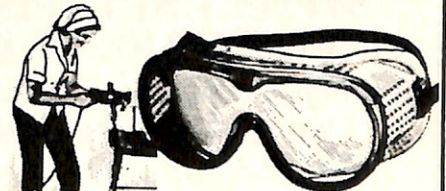

Invaluable when using any power tool. Full-visibility lenses of high-impact plastic placed in a soft face-fitting frame of ventilated flexible plastic—with extra wrap-around protection at sides and top. Adjustable elastic headband fits all. Featherweight, for extra comfort \$2.45 p.p.d. (A \$5.00 value.)

SAVE MORE! TWO FOR \$14.95 ONLY

FULL INSTRUCTIONS AND WARRANTY INCLUDED—SATISFACTION GUARANTEED! RUSH ORDER COUPON

JOHN STURGES Dept. SSK-7, 49 Riverside Ave., Westport, CT 06880

Please rush.....SUPER STRIPPER(S) @ \$7.77 ea., plus .75* handling. Sorry, no CODs

Order: COARSE for big jobs FINE for furniture Save more! Order both for \$14.95, plus \$1 postage.

Also rush _____ SOFT GOGGLES @ \$2.45 ea. p.p.d.

2 Strippers (coarse & fine) plus goggles only \$18.40 postpaid.

Enclosed is \$ _____ (Please add applicable sales tax.)

CHARGE: BankAmericard/Visa Master Charge Interbank # _____

Acc't. # _____ Exp. Date _____

Signature _____

PRINT NAME _____

ADDRESS _____

CITY _____ STATE _____ ZIP _____

© The John Sturges House, Inc., 1978

Dealers' Inquiries Invited.

50-Piece Set Pistol-Handled Flatware of 1776...

PURCHASE
OF A
LIFETIME

Only \$22.95

While Supplies Last

**50 PIECE SET... PISTOL-HANDLED
FLATWARE OF 1776 ...Beautifully
reproduced in stainless steel with the
satin-finish look of antique pewter.
NOT \$44.95! NOT \$34.95! ONLY \$22.95!**

Your home can reflect the candlelight appeal and gracious atmosphere of Early American Colonial elegance when you grace your table with this incredibly beautiful service. Through a special purchase, we can offer you the famous Pistol-Handled Flatware with all its stunning Colonial simplicity in magnificent, satin finish stainless steel at just a fraction of what you would pay for luxurious Sterling Silver. Each and every piece is a lovely replica of the graceful place settings that highlighted many a candlelit Colonial dinner. The knives are the genuine hollow pistol grip handles; the forks are the graceful 3-tined design. And the entire 50-Piece Set is made of modern stainless steel, to give you years of carefree service.

LIMITED SUPPLY AVAILABLE AT THIS VERY SPECIAL LOW, LOW PRICE Don't be disappointed! Take advantage of this amazing low price while our supplies last. Order now and we'll send you the complete service for 8 including 8 Pistol Grip Hollow Handle Knives; 8 Dinner Forks; 8 Salad Forks; 8 Soup Spoons; 16 Teaspoons PLUS a SPECIAL FREE GIFT of a matching Butter Knife and Sugar Spoon—50 pieces in all. The entire set is yours for just \$22.95 on full money back guarantee if you are not absolutely delighted. But don't delay. Due to the rising cost of quality stainless steel, the price of this set will be increased in the very near future. Take advantage of our truly low price while current supplies last. Mail coupon today!

Complete
Luxury
Service
For
8



LIMITED SUPPLY
Mail Your Order
Today!

**CROWN-CASTLE Ltd., Dept. PGP-763
51 Bank Street, Stamford, Conn. 06901**

Please send me the Stainless Steel Pistol Grip Flatware I have checked below on full Money Back Guarantee if I am not absolutely delighted.

(Please add \$2.00 postage and handling with each order.)

Check Quantity Desired

- Service For 8 (50-Piece Set) \$22.95
- Service For 12 (74-Piece Set) 33.95
- Service For 16 (100-Piece Set) 44.95

Enclosed is \$ _____

Charge my BankAmericard American Express Master Charge

Card No. _____ Exp. Date _____

Signature _____

Name _____ (Please Print Clearly)

Address _____

City _____

State _____ Zip _____

Conn. Residents Add 7% Sales Tax

NEVER AGAIN DRIVE A DIRTY CAR!



Super-action Miracle Car Brush keeps your car "showroom new"... without water, waxes or hard work!

Brush lasts for years!

Do people judge you by the soiled, grimy-looking automobile you drive? Now you can keep your car gleaming clean and bright—with that shiny "showroom-new" look. And you don't need a hose, you don't need a bucket, you don't need costly waxes, pastes or cleaners. What's more, you don't have to line up every Saturday to plunk down \$1.50 or \$2.00 for a car wash.

All you need is this super-action Miracle Car Brush and a few minutes of spare time.

Never again be ashamed of how your car looks!

This remarkable, chemically-treated Miracle Car Brush cleans and polishes your whole car in minutes—without water, waxes or hard work. It's almost like magic! Millions of dirt-hungry fibers attract dust and grime *automatically*—by molecular magnetism *then gobble it up!* You never have to rub or scrub. Simply *glide* the Miracle Car Brush over your car. It actually cleans as it polishes...is 100% safe even for new car finishes—even for a Rolls, Caddy or Continental!

Switch to this amazing no-water method!

Say goodbye forever to hoses, buckets and sponges! Never again risk rust, rattles, squeaks—and wet feet! This amazing, easy-care, *no water* way to clean your car is already used and preferred by millions. Bring back the gleaming-clean beauty of your automobile. Drive with pride...win compliments from friends and neighbors. Best of all, save \$75.00 to \$100.00 in car wash money! Your chemically-treated Miracle Car Brush costs only \$2.99—and stays effective up to 12 months. (Then you can renew it.) Brush itself lasts for years!

Quickly pays for itself!

Figure out how much car washes are costing you—and you'll see how the Miracle Car Brush *pays for itself in only two to four weeks!* And—incredible as it may seem—it *MUST* work the way we say...or *it costs you nothing!* Check our no-nonsense 90-day guarantee...and be convinced. Then mail the risk-free coupon *today* for sure!

MILLIONS SOLD IN AMERICA! NOW ONLY \$2.99



So effortless, a child can do it.



Fantastic inside your home, too. On furniture, floors, blinds.

90-DAY MONEY-BACK GUARANTEE!

Use Miracle Car Brush for 90 days. You **must** be absolutely delighted with it—or return for prompt refund of purchase price.

BUY WITH CONFIDENCE! ORDER TODAY!

JAY NORRIS Corp., 31 Hanse Ave.
Dept. 105-30, Freeport, N.Y. 11521

- Please rush me one **Miracle Car Brush** #91073 at purchase price of \$2.99 plus 90¢ shipping and handling.
- SAVE!** Order TWO #91081 at purchase price of only \$5.50 plus \$1.00 shipping and handling.
- SAVE MORE!** Order FOUR #91103 at purchase price of only \$9.99 plus \$1.50 shipping and handling.

Enclosed is check or money order for \$ _____
Sorry, no C.O.D.'s—(N.Y. residents add sales tax.)

PRINT NAME _____

ADDRESS _____

CITY _____

STATE _____ ZIP _____

© **JAY NORRIS** Corp. 1978

31 Hanse Ave., Dept. 105-30, Freeport, N.Y. 11521
Serving Satisfied Customers For More Than 30 Years.

Canadian Residents please send orders to:
Jay Norris Canada Ltd., 8595 Langeller Blvd.,
Dept. 105-30, St. Leonard, Quebec H1P 3B6

LAST CHANCE!

This could be the **LAST TIME** you'll see

2 Pairs of Executive SLACKS for **17⁹⁵**

Gentlemen: *Beware the Runaway Inflation!* If you think you may be needing some good new executive slacks soon for business or vacation, GRAB THIS VALUE and be sure you have your full supply before rampant inflation blows prices up again! Haband, the mail order people from Paterson, NJ, have a huge inventory of over 50,000 pairs of top grade made-in-U.S.A. Executive Dress Slacks in stock now. In your exact size & color choice, at the lowest cost they'll ever be made again!

- Full cut for the mature figure, with plenty of room in the knees, crotch, seat and thighs!
- "Talon®" unbreakable nylon Zephyr Zipper
- "Ban-Rol®" no-roll inner waistband
- Good wide belt loops for today's wider belts
- Handsome slash front pockets
- Two deep back pockets, with button on wallet pocket
- Tough no-hole pocketing
- Taller looking straight leg model

100% NO IRON Permanent Press **WASH & WEAR**
TWO PAIRS for 17.95!

How can such a price possibly be?

Haband is one of America's biggest, most important distributors of executive clothing. We control extensive contracts for top quality 100% polyester DoubleKnits made BEFORE the big price increases. Since Haband prices are based on these pre-inflation costs, you will see an important difference in what we charge. Compare our slacks with what you would have to pay in your local haberdasher. You save on the original price! You save on Cleaner's Bills! And you save wear and tear on your more expensive clothing!

Build Your Own Personal Stockpile of these Deluxe EXECUTIVE SLACKS

See them at home at No Risk
 5 Colors to choose —
 Any 2 pairs for 17.95

3 for 26.75
 4 for 35.50

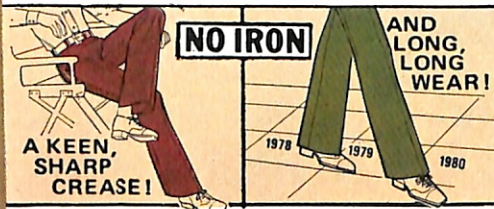

CONSUMER'S REVENGE! This could be the only way left to protect your purchasing power on clothing! In the next 12 to 36 months, rampant inflation is going to cut your dollar's worth everywhere. BUT HERE IS A CHANCE TO BEAT THE CRUNCH! We will be proud to send you any two pairs in your choice of size and color, direct to your home. Try them on. Show the family. Then decide. Read the guarantee on order form. But Hurry!

Haband's 100% Polyester Knit
NO IRON KNIT SLACKS, 2 pairs for 17⁹⁵
LAST CHANCE WHILE THEY LAST!

HABAND COMPANY
 265 N 9th St, Paterson, NJ 07530

Gentlemen: Please send me pairs of these slacks, for which I enclose my full remittance of \$

GUARANTEE: I understand that if, upon receipt, I do not choose to wear them, I may return the slacks immediately for a full refund of every penny I paid you!

72L-063

AVAILABLE IN SIZES:
 Waists 29-30-31-32-33-34-35-36-37-38-39-40-41-42-43-44-45-46-47-48-49-50-51-52-53-54.
 Inseams 26-27-28-29-30-31-32-33-34

COLOR	What	
	Waist	Inseam
Lt. BLUE		
TAN		
NAVY		
Dk. GREEN		
Dk. BROWN		

Name Apt. #
 Street
 City

HABAND

MAIL ORDER HOUSE
 265 North 9th Street
 Paterson, NJ 07530

State ZIP CODE [] [] [] [] [] []

HABAND COMPANY • Paterson, N.J.