

the
Elks

magazine
February 1978

The
Workaholic's
Woeful World



UNSINKABLE GOOD LOOKS



TRUE STORY! At 2 A.M. on the 10th day out in the South China Sea, a world-travelling Haband customer, a retired U.S. Army Colonel from California, awoke in horror to the scream of the ship's fire siren and jumped into his Haband Slacks. Cast away in an overloaded lifeboat, he endured a "most horrible ungodly typhoon, eventual pickup by a Japanese tanker & an overland trip thru the jungle to Singapore." Back home after his 3-day ordeal, the press reported these made-in-U.S.A. Haband Knit Dress Slacks could not be distinguished from the other fresh-from-the-dry-cleaner's trousers in his closet!

Interested in such Absolute Perfection in Long Wear for Yourself?

Meet Haband's World-Famous

NO IRON KNIT SLACKS

Look! Business Slacks are Haband's Business, and these are the slacks that today's best-dressed executives are wearing to the office, to their clubs, and on International Travels. Full cut, stylish, 100% Permanent Press! Slacks that look like they cost \$25 per pair! But you do not have to pay such prices!

2 Pairs for Only **17⁹⁵** MADE IN U.S.A.

TOP TAILORING DETAILS:

- Deluxe fully constructed "Ban-Rol®" no-roll waistband
- Hook Top Closure • Full, no-pucker fly with unbreakable nylon spiral zipper • Heavy, long-wearing no-hole pocketing •
- 2 good deep back pockets •
- 2 stylish and comfortable front slash pockets. • Stylish new wider belt loops.



Yessiree! In a time when every man has to watch what he spends, many smart business and professional men have turned to Haband where they can count on good quality and honest long wear. **And now is a good time for you to take advantage of our low 2 for 17.95 deal too!** We will be proud to send you any two pairs in your exact choice of size and color for your convenient **AT-HOME APPROVAL**. Try them on. Show your wife and family. Then decide. Read the complete **GUARANTEE** on easy order form. And, **ACT AT ONCE!**

Haband's 100% polyester NO-IRON

KNIT SLACKS

2 pairs for **17⁹⁵** POSTPAID

3 for 26.75 4 for 35.50

HABAND Company, Direct Service Dept.
265 North 9th St., Paterson, NJ 07530

Sirs: Please send pairs, for which I enclose \$ to be refunded in full

if on receipt I do not choose to wear them.

OR
Charge to: MasterCharge VISA (BankAmericard)

Acct# _____ Exp. ____/____/____

Name _____ Apt. # _____

Street _____

City _____

State _____ ZIP CODE _____

AVAILABLE IN SIZES:

Waists 29-30-31-32-33-34-35-36-37-38-39-40-41-42-43-44-45-46-47-48-49-50-51-52-53-54.

Inseams 26-27-28-29-30-31-32-33-34

COLOR	What Waist	What Inseam
Lt. BLUE		
TAN		
NAVY		
Dk. GREEN		
Dk. BROWN		



Order Direct by U.S. Mail from

HABAND

265 N 9th St. Paterson, NJ 07530

The Grandeur of America



An exquisite collection of 36 proof-quality medals, in strictly limited editions
 • SOLID STERLING SILVER • 24 KT. GOLD ON STERLING SILVER • 14 KT. SOLID GOLD

If you have ever personally thrilled to the surging power and grace of Old Faithful . . . marveled at the soaring spans of the Golden Gate Bridge . . . or watched in hushed wonder as the early morning haze rose off the Blue Ridge Mountains . . . then you will welcome this very special opportunity. Now you may relive those precious moments—over and over—through your own personal collection of those cherished landmarks of scenic wonder that are so much a part of our shared national heritage.

To mark America's entry into its third century, The Lincoln Mint will issue a limited-edition medallion art collection, THE GRANDUR OF AMERICA, dedicated to preserving the beauty of our national treasures in the imperishable medium of precious metals.

Masterpieces of Authentic Detail

Thirty-six subjects in all were chosen to be depicted. Places beloved by all Americans, ranging from Niagara Falls to the Grand Canyon, from the Washington Monument to the giant Redwood forests, with each medal conveying in meticulous and painstaking detail, an authentic sense of the true breadth and scope of the scene it portrays.

Medals will be individually struck from hand-polished dies to demanding proof-quality standards, producing a richly detailed sculpture that stands out in bold, frosted bas-relief against a brilliant mirror-like background. The proof-quality finish is protected from tarnish and wear by The Lincoln Mint's own exclusive mirror-brite process. The medals measure an impressive 1½ inches in diameter—larger than the American silver dollar. Each medal will be accompanied by a specially prepared profile, vividly describing the site depicted.

Strictly Limited Editions

To assure the authentic rarity of The Grandeur of America collection, it will be minted in three strictly limited editions: only 5,000 sets in Solid Sterling Silver; 5,000 sets in 24 Kt. Gold-on-Sterling Silver (each medal in these two editions contains one full troy ounce of Solid Sterling

Silver); and a special Archive Edition of 500 sets in 14 Kt. Gold, with each medal weighing a full 220 grains. The Archive Edition will be accompanied by a serially numbered Certificate of Authenticity.

You Receive One Medal A Month

The first medal in your collection will be delivered to you after your application is received and accepted. You will then receive one medal each month, together with an invoice for the next month's medal, until your set is complete. However, you may for any reason return the first medal within 15 days for full refund or credit.

Your Price Is Guaranteed

If the past is any indication, the prices of gold and silver on the International Metals Market are virtually certain to continue rising. However, as long as you continue on a monthly basis,

The Lincoln Mint *guarantees* that your price per medal will not be increased for the life of your subscription.

Special Display Chest Included

A custom-designed collector's chest of handsome American hardwood will be sent to you after your fifth medal, to house and protect your collection.

Please Be Sure to Act Promptly!

All applications will be accepted on a first-come, first-served basis with a limit of one set per subscriber. Once the entire issue is allocated, subsequent applications will be returned. So please act promptly—the earlier your reservation is postmarked, the greater your chance of acceptance.

To order by telephone—call toll free:
800-621-8318 (In Illinois, call 800-972-8308.)

SUBSCRIPTION APPLICATION

Mail to:
 The Lincoln Mint
 One South Wacker Drive, Chicago, Ill. 60606

Please enter my subscription for The Grandeur of America Collection, consisting of thirty-six proof-quality medals, to be issued to me at the rate of one medal per month. I will receive, at no additional cost, the custom-designed hardwood display chest.

I wish my proof-quality set minted in (check one)

- Solid Sterling Silver at \$19.50 per medal.*
 24 Kt. Gold-on-Sterling at \$24.50 per medal.*
 Archive Edition in Solid 14 Kt. Gold at \$195.00 per medal.*

Payment Plan (please check one):

- I enclose my check or money order (payable to The Lincoln Mint) for the first medal.
 BILL ME. I enclose no money now, and will pay for my first medal upon receipt of your invoice.

Please charge my subscription to:

- Master Charge American Express
 BankAmericard

Acct. # _____

Exp. Date _____

If using Master Charge indicate
 4 digits above your name: _____

Name _____

Please Print

Address _____

City _____ State _____ Zip _____

Telephone (_____) _____

Signature _____

(Required when using credit card.)

All subscriptions subject to acceptance by The Lincoln Mint.

*Illinois residents please add 5% sales tax.

114

A message from the Grand Exalted Ruler

Now Is The Time . . .

It won't be long. Soon the ice will be moving out. The crocuses will be reaching for the sky. Trees will be budding and ducks winging northward. It's just another way of saying that this is February and there are only two more months for every good Elk to come to the aid of his Lodge. Good intentions don't count, not in the clean-up season, which is now.

The Subordinate Lodge year is drawing to a close. But—there is still time to introduce that new member you have had in mind—if you do it now. You'll enjoy the feeling of being a builder.

Have you checked with your Lodge secretary to learn if there is a friend or acquaintance whose dues are delinquent? If there is you can do him, yourself and your Lodge a big favor by getting him to send in his check. And while you are at it, see if there isn't some lapsed member whom you could reinstate before March 31. Let's welcome the strays.

If you have become a participating member of the Elks National Foundation, or sponsored a member, then you have made a significant contribution to the progress of your Lodge and to the ability of our Foundation to serve as a powerful instrument for improving life in these United States. But why stop there? There's time to recruit another Foundation contributor.

During these next two months your Lodge Officers and committees will be working hard on these and other programs. Their success will mean more than just a fine record for the year. It will mean a stronger Lodge and a better Lodge.

They need the help of every member. Now—more than any other time—is when **Individual Responsibility Assures Progress.**

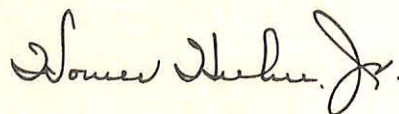

Homer Huhn, Jr.



**"Individual
Responsibility
Assures Progress"**

Get hold of a real drink of whiskey.



YELLOWSTONE

For 140 years the
greatest American whiskey.®

Kentucky Straight Bourbon Whiskey, 86, 90 and 100 Proof Bottled in Bond, Yellowstone Distillery Company, Louisville, Kentucky, © 1978.

LCD Watch Breakthrough ... Constant Display Alarm Watch



a 6-Digit
6 function
LCD Alarm
Watch for
only \$54.95

At last, a constant readout (no buttons to push) precision quartz electronic watch with a built-in 24-hour alarm system.

The alarm

The incredible 24-hour alarm system allows you to preset your watch to signal you at any minute, day or night. Once set you can relax. The alarm watch has an unfailing memory!



Set to Ring
at 7:55 A.M.

Snooze remind control

The alarm gives you the convenience of a short beep before its 15 second cycle, enabling you to turn it off without disturbing others. If a further reminder is desired, the snooze remind control will cycle the alarm again in 5 minutes.

6-digit LCD display

This display gives you a continuous LCD (Liquid Crystal Display) (no buttons to push) and a convenient 6-digit readout showing hours, minutes and seconds in a glance. A push button night light gives you dial visibility even in darkness.

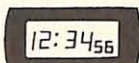

12:34 and 56
Seconds

Calendar display

Just a push of the button converts the time display into a 6-digit month, date, day display. The watch module automatically remembers the correct number of days in the month

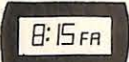

Friday Aug 15th

Quartz accuracy

Timepiece accuracy as only quartz can make it! Guaranteed to 15 seconds per month.

15 DAY TRIAL

Wear the LCD ALARM WATCH for 15 days to assure yourself that this is no ordinary watch. If at the end of that time you are dissatisfied for any reason, you may return it for a prompt refund, no questions asked.

1 YEAR LIMITED WARRANTY

To order by credit card please phone our 24-hour TOLL FREE NUMBER:

800-325-6400 ask for Oper. 54

In Missouri: 800-342-6600 ask for Operator 54

or mail the attached coupon with your payment and the LCD Alarm Watch will be on its way to you.

Allow 3-4 Weeks for Delivery

Winthrop-Rogers Ltd.

V1102

Box A69, 1135 Greenridge Rd., Buffalo Grove, IL 60090

Please send _____ LCD ALARM WATCH @ \$54.95 each plus \$1.99 for shipping and handling.

Silvertone LCD ALARM WATCH

Goldtone LCD ALARM WATCH

If I am not completely satisfied I may return it for a full refund. Total amount enclosed \$ _____ check or money order. (Illinois res. please add 5% sales tax.) No C.O.D.'s please.

Charge: Amer. Exp. Bank Amer./Visa
 Master Charge MCB# _____

Please print:

Card # _____ Exp. _____

Signature _____

Name _____

Address _____ Apt. _____

City _____ State _____ Zip _____

To expediate shipping by UPS, please provide street address rather than P.O. Box number.

the ELKS magazine

VOL. 56, NO. 9 / FEBRUARY, 1978

NATIONAL PUBLICATION OF THE BENEVOLENT AND PROTECTIVE ORDER OF ELKS OF THE UNITED STATES OF AMERICA. PUBLISHED UNDER THE DIRECTION OF THE GRAND LODGE BY THE NATIONAL MEMORIAL AND PUBLICATION COMMISSION.

THE ELKS NATIONAL MEMORIAL AND PUBLICATION COMMISSION

WADE H. KEPNER/Chairman

R. LEONARD BUSH/Vice-Chairman

RAYMOND C. DOBSON/Secretary

EDWARD W. McCABE/Treasurer

ROBERT E. BONEY/Asst. Secretary and Asst. Treasurer

JOHN R. RYAN/Publisher/General Manager

JEFFREY BALL/Managing Editor

MARY M. CAVANAGH/Fraternal News Editor

MALCOLM B. CROFFORD/Circulation Manager

EDITORIAL OFFICES, 425 W. Diversey Parkway, Chicago, IL 60614

8 The Woeful World of the Workaholic

"Physically and psychologically, failure to relax is probably as destructive as heroin . . ."

Frank Thistle

12 Where The Action Is . . .

The "Action" movement is as American as apple pie; to read them is to feel the pulse of the average citizen.

Walter Oleksy

30 Hidden Treasure is Everywhere

From pirate booty to earrings, there's billions of dollars waiting—and modern technology is making finding it easier.

Larry Holden

Departments

2 Message

6 It's Your Business: Image

14 Elks National Foundation/
Joy of Giving

16 Visits of Homer Huhn, Jr.

17 News of the Lodges

23 Travel: Samoa

26 Medicine and You: Atomic Life

28 You and Retirement: Legal Affairs

33 Major Projects: CA-HI/ME/VT

42 Elks National Service Commission

44 Elks Family Shopper/
More For Your Money

Cover: Expanding Office Hours

Jim Lavengood

ADVERTISING OFFICES



CHICAGO 60614 425 W. Diversey Parkway (312) 528-4500

NEW YORK 10017 50 East 42nd (212) 682-2810

POSTMASTER: Mail notices of address corrections to:

THE ELKS MAGAZINE, Circulation Dept., 425 W. Diversey Parkway, Chicago, IL 60614

MEMBERS: Changes of address should be made through your lodge Secretary. Give him advance notice of at least 30 days. Remember that the day you write, your next copy is already in the mails. Before you move, file your new address at the post office to have mail forwarded. In writing us regarding an address change, please give: Full name, lodge number, membership number, address to which copy is being mailed, and complete new address. Attach label from recent issue if available. Please show ZIP Code numbers in both old and new address.

THE ELKS MAGAZINE, Volume 56, No. 9, February, 1978. Published monthly at 425 W. Diversey Pkwy., Chicago, IL 60614 by the Benevolent and Protective Order of Elks of the United States of America. Second class postage paid at Chicago, IL, and at additional mailing office. Acceptance for mailing at special rate of postage provided for in Section 1103, Act of October 3, 1917, authorized May 20, 1922. Single copy price 25 cents. Subscription price in the United States and its Possessions, for Elks, \$1.25 a year, for non-Elks, \$2.50 a year; for Canadian and Foreign postage, add \$1.00 a year. Subscriptions are payable in advance. Manuscripts must be typewritten and accompanied by sufficient postage for their return via first class mail. They will be handled with care but this magazine assumes no responsibility for their safety.

The word, Elks, is a registered trademark of The Benevolent and Protective Order of Elks of the United States of America. Copyright, 1978, by the Benevolent and Protective Order of Elks of the United States of America



454

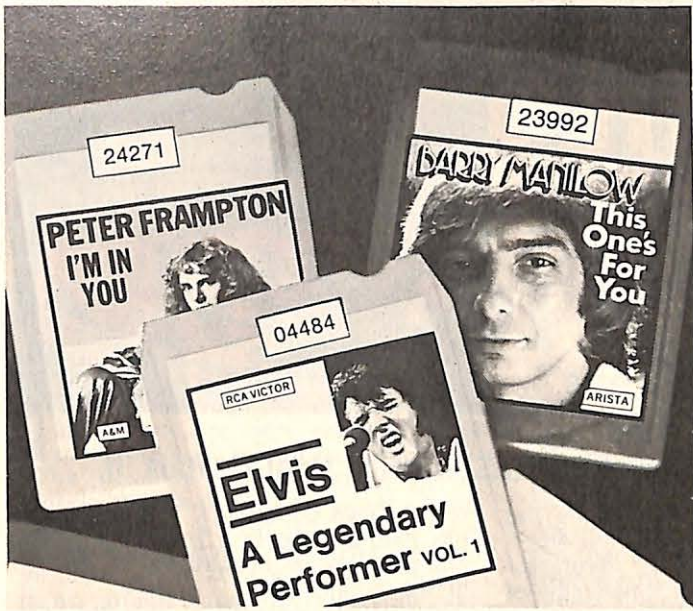

Wow!

The RCA Music Service is having a

1¢ SALE

Take any 6 tapes or records for only 1¢ — plus postage and handling — when you agree to buy just 4 more hits at regular Music Service prices and take up to three full years to do it.

Save on Your Choice of 8-Track Tapes or Records or Cassettes

Start Saving Now! Take any six 8-Track Tapes or Records or Cassettes for just 1¢ with trial membership. (Sorry, no mixing.) Indicate your choices on the coupon, enclose your penny, and mail it today!

Colorful Magazine! Free Choice! Every four weeks illustrated MEDLEY brings news of over 400 selections and features a "Selection of the Month" in your favorite music category. And, five times a year, you receive sale issues featuring a "Bonus Selection" and alternates at great savings. In all, you will have 18 purchase opportunities in the course of a year. No need to buy a selection every time. You merely agree to buy 4 more hits in the next three years at regular prices—usually \$6.98—\$7.98 for records, \$7.98 for tapes. Choose from top labels like RCA, Capitol, Warner Bros., Reprise, A&M, Atlantic, Atco...over 80 more!

Automatic Shipments! To get the regular "Selection of the Month" or the special sale "Bonus Selection," do nothing; it will be sent automatically. If you want other selections, or none, advise us on the card always provided and return it by the date specified. You always have at least 10 days to decide. But, if you ever have less than 10 days to make your decision, you may return your automatic selection at our expense for full credit.

Cancel whenever you wish after completing your membership agreement by notifying us in writing. If you remain a member, choose 1 selection FREE for every 2 you buy at regular Music Service prices! (Postage and handling charge added to each shipment.)

Free 10-Day Trial! If not satisfied, return your 6 hits after 10 days for prompt refund. Mail coupon today.



- DARYL & JOHN HALL & OATES: BIGGER THAN BOTH OF US (RCA) 14526
- ARTUR RUBINSTEIN: WORLD'S FAVORITE CHOPIN (RCA) 13362
- THE CAPTAIN & TENNILLE: LOVE WILL KEEP US TOGETHER (A&M) 33730
- DON WILLIAMS: GREATEST HITS (A&M) 31994
- BAY CITY ROLLERS: IT'S A GAME (A&M) 30685
- SUPERTRAMP: EVEN IN THE QUIETEST MOMENTS (A&M) 24272
- GRAND FUNK HITS (CAPITOL) 33939
- GLEN CAMPBELL: SOUTHERN NIGHTS (CAPITOL) 24270
- RONNIE MILSAP: LIVE (RCA) 33979
- THE BROTHERS JOHNSON: RIGHT ON TIME (A&M) 14512
- Sunday Morning with CHARLEY PRIDE (RCA) 24111
- TWIN SETS: Double the music Count as one!
- *ELVIS' WORLDWIDE Gold Award HITS Parts 1 & 2 (RCA VICTOR) 13690
- *FRAMPTON COMES ALIVE! (A&M) 23558
- *BEACH BOYS: ENDLESS SUMMER (CAPITOL) 23559
- *BARRY MANILOW: LIVE (ARISTA) 04607
- *THE GRAND OLE OPRY: 1926-1974 (RCA) 04442
- *AN EVENING WITH JOHN DENVER (RCA) 14339
- *THE BEST OF ROD STEWART (MERCURY) 41369

- Original Cast: FIDDLER ON THE ROOF (RCA) 00051
- RITA COOLIDGE: ANYTIME...ANYWHERE (A&M) 24126
- THE BEST OF GLENN MILLER VOL. 3 (RCA) 10090
- DOLLY PARTON: NEW HARVEST FIRST GATHERING (RCA) 23812
- CAT STEVENS: IZITSO (A&M) 24362
- WAYLON JENNINGS: "LIVE" (RCA) 32142

More Hits To Choose!

- B. Manilow: Feelin' ... 34006
- Best Of Freddy Fender ... 14013
- Frampton: Wind Change ... 14505
- Segovia: Span. Encores ... 04486
- Steve Miller: Dreams ... 14443
- South Pacific ... 00049
- Best Of Beach Boys ... 23946
- Best Of Dolly Parton ... 33508
- Best Of BTO ... 43597
- C. Craddock: Gr. Hits ... 42485
- ZZ Top: Fandango ... 13864
- Neil Sedaka: Gr. Hits ... 24171
- Nazareth: Hair Of Dog ... 33747
- Hair ... 03292
- Kiss: R & R Over ... 33990
- Best Of Glen Campbell ... 20382
- Ohio Players: Gold ... 30281
- Best Of Donna Fargo ... 30642
- Best Of Guess Who ... 04306
- Best Of Best Haggard ... 33505
- Dr. Hook: Little Bit ... 34041
- Mills Bros.: Gr. Hits ... 04482
- 3 Dog Night: Gr. Hits ... 24056
- Roy Clark In Concert ... 43589
- Kris & Rita: Full Moon ... 20913
- John Denver: Gr. Hits ... 13777
- Supertramp: Crime ... 24246
- Elvis: Country ... 14026
- Kiss ... 34335
- Best Of Statler Bros. ... 13572
- Floater ... 14586
- Helen Reddy: Gr. Hits ... 32302
- Sil. Conv.: Gold. Girls ... 14600
- Ol' Waylon ... 14500
- Poco: Indian Summer ... 14564
- Carpenters: Passage ... 40023
- Best Sons Of Pioneers ... 13430

- FREDDY FENDER: Before The Next Teardrop Falls (RCA) 33352
- STEVE MILLER BAND: FLY LIKE AN EAGLE (CAPITOL) 23759
- HELEN REDDY: EAR CANDY (CAPITOL) 40050
- PABLO CRUISE: A PLACE IN THE SUN (A&M) 33941
- CARPENTERS: The Singles 1969-1973 (A&M) 04393
- HANK WILLIAMS': GREATEST HITS (MGM) 23656

More Hits To Choose!

- Peter Frampton ... 04647
- Capt. & Tenn.: Song Joy ... 14405
- Jeff. Star.: Spittire ... 14279
- Charlie Rich: Gr. Hits ... 04631
- Cat Stevens: Gr. Hits ... 20015
- Shenandoah ... 23591
- S. Bishop: Careless ... 22521
- Dave & Sugar ... 24282
- TJB: Gr. Hits ... 00295
- L. Ronstadt: Wheel ... 13933
- G. Campbell: Gr. Hits ... 24107
- Natalie Cole ... 33409
- Tom T. Hall: Gr. Hits ... 13249
- Elvis: Legendary V. 2 ... 14466
- Rod Stewart: Sing It ... 14392
- Paul Anka: 21 Gold Hits ... 00120
- Bob Seger: Night Moves ... 43584
- Roy Clark: Gr. Hits ... 23644
- BTO: 4 Wheel ... 14360
- Outlaws ... 33275
- Tom Jones: Gr. Hits ... 23674
- Steppenwolf: 16 Hits ... 13453
- Mancini's Angels ... 14012
- Chuck Berry: Gold ... 13728
- J. Cash: Orig. Gold V. 1 ... 04024
- B. Bacharach: Gr. Hits ... 21151
- Kiss: Destroyer ... 24001
- McCoo/Davis: 2 Of Us ... 40136
- Rush: 2112 ... 33716
- Best Of Jim Reeves ... 00267
- Platters: Gold ... 01129
- Perry Como: Gold ... 03908
- Tavares: Love Storm ... 24180
- Best Of Eddy Arnold ... 02318
- Bros. Johnson: #1 ... 23713
- H. Williams: Gr. Hits V. 2 ... 23658
- Best Of Sam Cooke ... 00243

ACT NOW! MAIL COUPON TODAY!

Mail to: RCA MUSIC SERVICE
P.O. Box RCA 1, Indianapolis, Ind. 46291

1. I enclose 1¢. Please accept my trial membership in the RCA Music Service and send me the 6 hits I've indicated here under the terms outlined in this advertisement. I agree to buy as few as 4 more hits at regular Music Service prices in the next three years, after which I may cancel my membership. (Postage & handling charge added to each shipment.)

2. SEND MY SELECTIONS ON (check one only):
 8-TRACK TAPES RECORDS CASSETTES

3. I am most interested in the following type of music — but I am always free to choose from every category (check one only):
 1- EASY LISTENING (Instrumental/Vocal)
 2- COUNTRY 3- TODAY'S SOUND (Rock/Soul/Folk)
 4- BROADWAY-HOLLYWOOD-TV 5- CLASSICAL

4. RUSH ME THESE 6 SELECTIONS (indicate by number):

5. MR. MRS. MISS (Please Print)

Address _____
 City _____ State _____
 Phone (____) _____ Zip _____
 Area Code

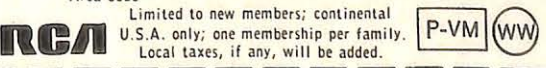

Limited to new members; continental U.S.A. only; one membership per family. Local taxes, if any, will be added.

RCA Music Service reserves the right to request additional information or reject any application.

RSC 399 TRADEMARKS USED IN THIS ADVT. ARE PROPERTY OF VARIOUS TRADEMARK OWNERS, TM&SI © RCA CORPORATION.
 SELECTIONS MARKED © ARE STEREO EFFECT REPROCESSED FROM MONOPHONIC.

Planer Molder Saw

3 Power **TOOLS** in **1**
Feed

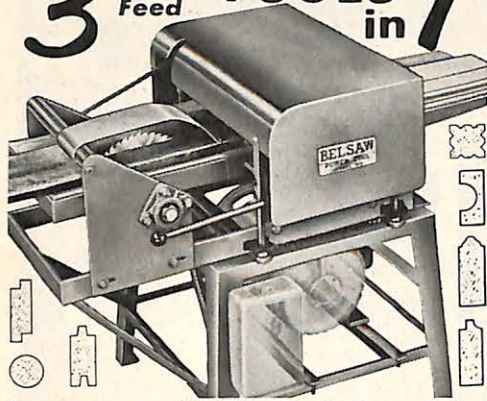

Now you can use this ONE power-feed shop to turn rough lumber into moldings, trim, flooring, furniture—ALL popular patterns. RIP-PLANE-MOLD . . . separately or all at once with a single motor. Low Cost . . . You can own this power tool for only \$50 down.

30-Day FREE Trial! SEND FOR EXCITING FACTS
NO OBLIGATION—NO SALESMAN WILL CALL
RUSH COUPON BELSAW POWER TOOLS CO.
TODAY! 4215 Field Bldg.
Kansas City, Mo. 64111

BELSAW POWER TOOLS
4215 Field Bldg., Kansas City, Mo. 64111

YES Please send me complete facts about PLANER—MOLDER—SAW and details about 30-day trial offer.

Name _____
Address _____
City _____
State _____ Zip _____

Men's Wide Shoes

EE to EEEEE • Sizes 5-13

More than 100 styles for every purpose. Top quality. Sensible prices. Not sold in stores. Send for FREE CATALOG.



Hitchcock

SHOES, INC.
Dept. 11B Hingham, Mass. 02043

Handwriting REVEALS ALL!



Writing is a direct reflection of the Inner Self—and little is concealed from those who can analyze handwriting. The value of handwriting analysis (Graphology) is proven daily in pre-marriage and family counseling, personnel selection and in business. Once developed, Graphology skills offer immense personal satisfaction. You'll astound friends with your insight . . . entertain at social functions, parties and club meetings. Write for FREE booklet—no obligation. Institute of Graphology, 412 S. Lyon St., Dept. NSR, Santa Ana, Ca. 92705

HYDRAULIC JACK REPAIRS

Earn While You Learn In Your Spare Time

Trained and qualified mechanics needed NOW to service inoperative hydraulic jacks. BIG opportunity for ambitious men. We show you HOW—in your basement or garage to earn spare time cash in an expanding industry. Don't wait, ACT NOW! Get the facts.

Write for folder E2 and free bonus offer

Hydraulic Jack Repair Manual Co., Inc.
G. P. O. BOX 3 • STATEN ISLAND, N. Y. 10314

HEARING AIDS

\$UPER SAVINGS! Newest. Finest. All types. Buy DIRECT & save up to HALF! No salesmen. Sold by AIR MAIL on HOME TRIAL. FREE Catalog. Write: **MONEYSAVERS**, Dept. EK-2, 9530 Langdon Ave., Sepulveda, Cal. 91343

SAVE 1/2!

FREE CATALOG—WRITE!

IT'S YOUR BUSINESS

by John C. Behrens

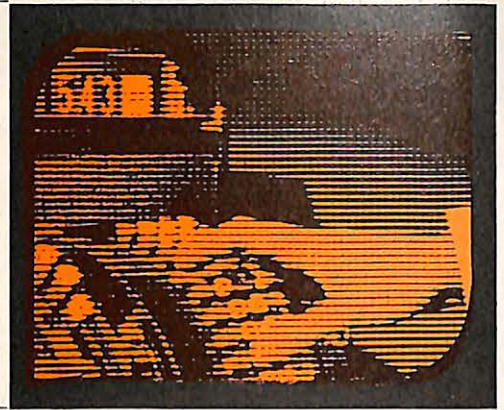

CHANGING THE BUSINESSMAN'S IMAGE, Part II

"It is very difficult to determine the average person's stereotype of the American businessman," says Professor George Vredeveld of the University of Cincinnati, an economist who is trying to change the public's perception of business and those who manage.

"Studies have suggested that the businessman is not looked up to as someone who is highly respected but this does not suggest the businessman is looked upon as a disreputable person. Overall, I think the businessman is viewed as a conservative individual, one who has a narrow focus in life, equity or other social problems except as they relate directly to business," he explains. Many agree.

"Probably people are more cynical of businessmen," says Tom Roden, president of Uniservice Risk Management, a member of the Utica National Group, New York, "because they think they're being manipulated. Consequently, they are cynical as they are in virtually all of their relationships. Maybe it has to do with our society. As a people, we lack community involvement; people are more transient so they don't develop close relationships with others. Perhaps that is the overriding problem that has created such attitudes."

Still others believe that the businessman must share some of the responsibility for creating such problems. "Business is in disrepute. So is the government and so is almost every facet of the free enterprise system. The demands of society are escalating and Congress has been passing legislation the way some people pop pills. The business community is out of step on consumer issues and as long as this is true business will continue to be attacked and regulated. Consumers believe that business is only out to make a profit," says Gene King, once the voice of Lamont Cranston and the "Shadow" (a popular radio mystery theater of the 1930s and '40s) now vice president for broadcasting and consumer education of the Council of Better Business Bureaus.

Business people have become unfamiliar to the public and the resulting lack of knowledge has led to misunderstanding, says Professor Vredeveld. "I feel that there has been a deliberate effort by businessmen to maintain a 'low profile.' They have failed to explain the goals and objectives, the successes and failures

of their own businesses. This low profile has naturally led to a misunderstanding and certainly an unfamiliarity on the part of the public."

But Vredeveld believes that the difficulties have been recognized and efforts are currently being made to bring about change.

"Recently, I have seen some signs that businessmen have made efforts to 'tell their story'. If they can do so in a candid and honest way which explains successes as well as failures, I think they will be very successful," he suggests.

Both King and Roden believe better communication between business and consumer can't simply be a goal; it must become a reality.

How can businessmen improve their image?

Professor Vredeveld thinks one way is separating what will work from what won't. "It has become apparent that certain things do not work," the University of Cincinnati economist points out. "We have seen evidence of advertising programs which extol the virtues of business in the free enterprise system and other advocacy programs. I personally think that these programs are not very effective and in some cases, have a negative effect. The primary reason for this is because they are not educationally sound. Students and educators have become accustomed to approaches by special interest groups which seek to change their attitudes and opinions concerning the attitudes of these groups . . . they are way of influences . . . of this sort."

To change the image of business and businessmen, Vredeveld continues, you must have a sound educational program which explains objectively how our economic system works and the very important and beneficial role of businesses within that system. "According to a national survey on the American economic system, conducted by the Advertising Council, the public has a favorable attitude toward the economic system in terms of personal freedoms and opportunities of mobility. In fact these attributes of our economic system are viewed to be more valuable or more important than the high standard of living and the wide variety of goods and services which the system produces.

"But the important thing to remember
(Continued on page 21)

The Ultimate Tax Shelter



by
TED NICHOLAS

Tax experts are now referring to a small, privately owned corporation as "The Ultimate Tax Shelter." This is especially true since the passage of the Tax Reform Act of 1976. This law makes most former tax shelters either obsolete, or of little advantage. Investments affected include real estate, oil and gas drilling, cattle feeding, movies, etc. These former tax shelters have lost their attractiveness. Aside from that, these tax shelters required a large investment. Only a small segment of the population could benefit from them.

I've written a book showing how you can form your own corporation. I've taken all the mystery out of it. Thousands of people have already used the system for incorporation described in the book. I'll describe how you may obtain it without risk and with a valuable free bonus.

A corporation can be formed by anyone at surprisingly low cost. And the government encourages people to incorporate, which is a little known fact. The government has recognized the important role of small business in our country. Through favorable legislation incorporating a small business, hobby, or sideline is perfectly legal and ethical. There are numerous tax laws favorable to corporate owners. Some of them are remarkable in this age of ever-increasing taxation. Everyone of us needs all the tax shelter we can get!

Here are just a few of the advantages of having my book on incorporating. You can limit your personal liability. All that is at stake is the money you have invested. This amount can be zero to a few hundred or even a few thousand dollars. Your home, furniture, car, savings, or other possessions are not at risk. You can raise capital and still keep control of your business. You can put aside up to 25% of your income tax free. If you desire, you may wish to set up a non-profit corporation or operate a corporation anonymously. You will save from \$300 to \$1,000 simply by using the handy tear-out forms included in the book. All the things you need: certificate of incorporation, minutes, by-laws, etc., including complete instructions.

There are still other advantages. Your own corporation enables you to more easily maintain continuity and facilitate transfer of ownership. Tax free fringe benefits can be arranged. You can set up your health and life insurance and other programs for you and your family wherein they are tax deductible. Another very important option available to you through incorporation is a medical reim-

bursement plan (MRP). Under an MRP, all medical, dental, pharmaceutical expenses for you and your family can become tax deductible to the corporation. An unincorporated person must exclude the first 3% of family's medical expenses from a personal tax return. For an individual earning \$20,000 the first \$600 are not deductible.

Retirement plans, and pension and profit-sharing arrangements can be set up for you with far greater benefits than those available to self-employed individuals.

A word of caution. Incorporating may not be for you right now. However, my book will help you decide whether or not a corporation is for you now or in the future. I review all the advantages and disadvantages in depth. This choice is yours after learning all the options. If you do decide to incorporate, it can be done by mail quickly and within 48 hours. You never have to leave the privacy of your home.

I'll also reveal to you some startling facts. Why lawyers often charge substantial fees for incorporating when often they prefer not to, and why two-thirds of the New York and American Stock Exchange companies incorporate in Delaware.

You may wonder how others have successfully used the book. Not only a small unincorporated business, but enjoyable hobbies, part time businesses, and even existing jobs have been set up as full fledged corporations. You don't have to have a big business going to benefit. In fact, not many people realize some very important facts. There are 30,000 new businesses formed in the U.S. each and every month. 98% of them are small businesses; often just one individual working from home.

To gain all the advantages of incorporating, it doesn't matter where you live, your age, race, or sex. All that counts is your ideas. If you are looking for some new ideas, I believe my book will stimulate you in that area. I do know many small businessmen, housewives, hobbyists, engineers, and lawyers who have acted on the suggestions in my book. A woman who was my former secretary is incorporated. She is now grossing over \$30,000 working from her home by providing a secretarial service to me and other local businesses. She works her own hours and has all the corporate advantages.

I briefly mentioned that you can start with no capital whatsoever. I know it can be done, since I have formed 18 companies of my own, and I began each

one of them with nothing. Beginning at age 22, I incorporated my first company which was a candy manufacturing concern. Without credit or experience, I raised \$96,000. From that starting point grew a chain of 30 stores. I'm proud of the fact that at age 29 I was selected by a group of businessmen as one of the outstanding businessmen in the nation. As a result of this award, I received an invitation to personally meet with the President of the United States.

I wrote my book, *How To Form Your Own Corporation Without A Lawyer For Under \$50*, because I felt that many more people than otherwise would could become the President of their own corporations. As it has turned out, a very high proportion of all the corporations formed in America each month, at the present time are using my book to incorporate.

Just picture yourself in the position of President of your own corporation. My book gives you all the information you need to make your decision. Let me help you make your business dreams come true.

As a bonus for ordering my book now, I'll send you absolutely free a portfolio of valuable information. It's called "The Incom Plan" and normally sells for \$9.95. It describes a unique plan that shows you how to convert most any job into your own corporation. You'll increase your take-home pay by up to 25% without an increase in salary or even changing jobs in many cases. If you are an employer, learn how to operate your business with independent contractors rather than employees. This means that you'll have no payroll records or withholding taxes to worry about. And you'll be complying with all I.R.S. guidelines. "The Incom Plan" includes forms, examples and sample letter agreements to make it possible.

I personally guarantee your purchase in the fairest way I know. If you feel my book is not all that I've described, return it undamaged within a full year and I'll promptly refund your money with no questions asked. If you should decide to return it, you may keep the bonus Incom Portfolio for your trouble.

To get your copy, write the words "Corporation Book and Bonus" on a plain sheet of paper, along with your name and address. Enclose a check for \$14.95. There is no sales tax on your order and your purchase price is tax deductible. Mail your order to me, Ted Nicholas, c/o Enterprise Publishing Co., Dept. EK-82C, 1000 Oakfield Lane, Wilmington, Delaware 19810. C1016

The Woeful World Of The Workaholic

by Frank Thistle

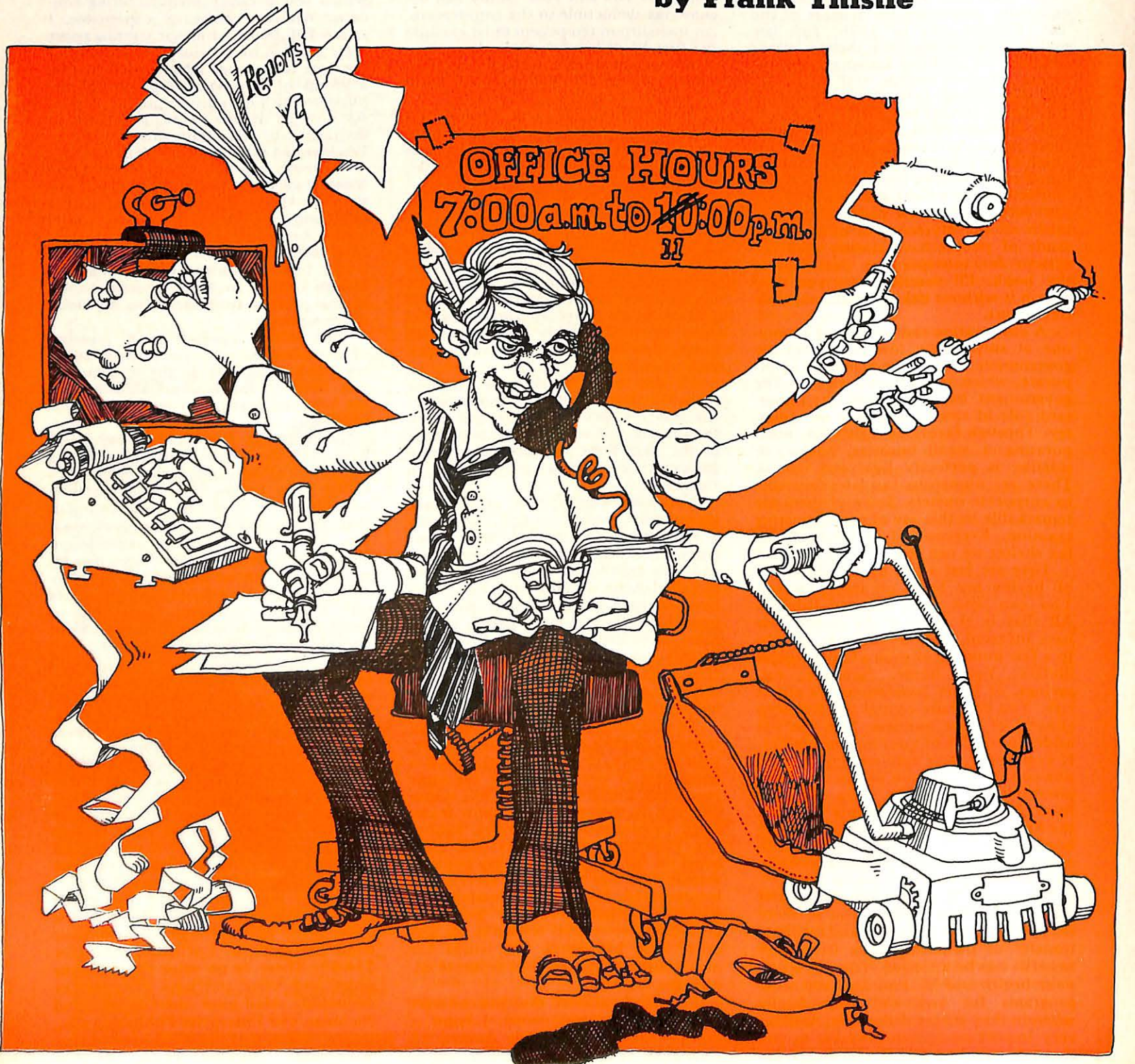

The Alcoholics Anonymous and Gamblers Anonymous organizations are well-known. But there is another disease sweeping the country that is just as potentially dangerous. Thousands of American men have become workaholics. They have been caught up in the work ethic and have gone overboard. If they don't learn how to let up and relax they are in for big trouble.

"Physically and psychologically, failure to relax is probably as destructive as heroin," says Dr. Francis L. Clark, assistant professor of psychiatry at Georgetown University in Washington, DC.

Clark claims that workaholics are more prone to cardiovascular disease and hypertension, the conditions that produce heart attacks and strokes. Furthermore, he says, they tend to suffer from depression and often feel frustrated.

"They end up constantly feeling inadequate because they can never fulfill the goals they think they should be fulfilling," he says.

Psychoanalysts say that the workaholic's drive is not primarily for money or stature, but to release tension within himself. If he is always bustling with activity, he doesn't have to think. And it is activity—not accomplishment—that is the workaholic's goal. That's the major difference between a person who works hard for healthy reasons and the workaholic who works for neurotic reasons.

Behavioral scientists say that one distinct difference between a hard worker and a workaholic is the workaholic feels uneasy when he isn't working. The hard worker doesn't. He can take a vacation and really enjoy it. A vacation for the workaholic is nothing but torment. He's only happy when he's involved in ceaseless activity.

Dr. Allan Cott, a New York psychiatrist noted for his work with children suffering from learning disabilities and hyperactivity, makes this revealing contrast between the hard worker and the workaholic:

"I think it's much like the difference between a healthy, active child and a superactive child. I believe the compulsive overworker does many things that are not very productive. He's filling up time. A healthy, active child will be curious and interested in everything he sees and many objects in a room will attract his attention, but he stays long enough with each object to learn something from it. The hyperactive child, on the other hand, has to keep on the move. He goes from one thing to another without getting any real meaning from it. Generally, it's perpetual, purposeless movement that stems from an inner uneasiness. I think the addictive worker would be much the same. Certainly adults of this type find retirement a threat and invariably deteriorate or die quickly. Vacations and weekends are a preview of what happens with them upon retirement. They become uncomfortable without ceaseless movement."

In what professions are workaholics most commonly found?

Dr. Edwin Hallsten, a St. Louis clinical psychologist, says: "Very often, he's in one of the 'helping professions.' He may be a clergyman, psychiatrist, psychologist, social worker or physician. If his wife or children complain that he's ignoring them, he has what seems like the perfect answer. He's out helping people. There's no way for them to fight that."

"No question about it," adds Dr. Russell Smith. "I have a son under treatment for drug addiction. His condition may have been a direct result of my overworking—and neglecting my family. I'm convinced that the dynamics of work addiction are the same as alcoholism or addiction to hard drugs. I look around at kids in trouble and invariably they are the children of social workers, psychiatrists, physicians or min-

isters. We've dedicated ourselves to 'hard work' and our families have suffered."

The Whitmore Lake, Michigan, doctor has supervised treatment of thousands of alcoholics and drug abusers in the past two decades.

"I've known several thousand work addicts in my practice," he says. "It should have made me a little quicker to recognize it in my own case."

As Drs. Hallsten and Smith have pointed out, doctors are often workaholics. Dr. Thomas E. Bittker, a Phoenix, Arizona, psychiatrist, says physicians who build successful careers by working 60 to 70 hours a week may be leaving themselves open to depression and suicide. The problem is further complicated, he says, because most doctors are hesitant to seek psychiatric help from colleagues.

"Alcoholism, drug abuse and suicide may be the end result for successful doctors whose problem stretches back to the characteristics that made the doctor successful in the first place," says Dr. Bittker. "The characteristics of self-sacrifice, perseverance, competitiveness and to some degree, a denial of feelings, are essential for the passage of the physician from student into a mature professional."

Dr. Bittker cites statistics that suggest that about 17,000—or from five to six per cent of the nation's doctors—are victims of alcoholism, drug abuse, or mental illness. Some physicians, he says, find their success only through the satisfaction of their patients, leading to a compulsive self-denial. Eventually the physician may become depressed and try to escape from the depression by working longer hours, seeking more material satisfaction or using drugs or alcohol, which can aggravate depression.

Not much has been written about workaholism because, unlike alcoholism or drug addiction, it is a socially acceptable disease. One of the first to shed some light on the subject was Wayne E. Oates. He had been a workaholic for nearly 30 years before he managed to kick the habit. He is a professor of the psychology of religion at Southern Baptist Theological Seminary in Louisville, Kentucky. Convinced that his old sickness is a common and crippling affliction, he recounted his experiences for the benefit of other sufferers in a book called *Confessions of a Workaholic* by World Publishing Co.

"The workaholic drops out of the human community," Oates says, "and eats, drinks and sleeps his job. Every morning he wakes at a set hour. At his office, he is merciless in his demands upon himself for peak performance and is without qualms about telling off both high and low when their work is sloppy. Arriving home late, he heads for his study to make the best of the remaining hours of the day, unable to tell the difference between simple loyalty and compulsive, overcommitment to his employers."

How does a workaholic know that he is one?

Sometimes he finds out only when he suffers a heart attack. But in Oates' case it was when his five-year-old son asked for an appointment to see him.

In his book, Oates says that there are many motivations for becoming a workaholic. Drudges sometimes feel guilty over pleasure, he notes, and take care not to get too much of it. The workaholic also has fantasies of omnipotence, imagining that no one but he can do what needs doing. He likes to make other people uncomfortable by accomplishing more than they do, and he enjoys feeling independent.

Says Oates: "As long as he has his work, he does not need anybody—he has power, place and things. The workaholic may use work as the philanderer uses sex: more and more of both ward off the anxiety of death."

Oates claims that workaholism is not confined to men. It can also strike females at home, in offices, in volunteer agencies, or even in Women's Lib. Afflicted housewives often overuse the phrase 'Let me do it' while complaining of having to clean up after everyone else. But compulsive housework is not the only symptom of work addiction evident in the home; there is also compulsive childbearing.

"It's one of the most exhausting types of work there is," says Oates. "The woman who has many children may simply be a workaholic."

Alan McLean, psychiatrist and eastern-area medical director for IBM, points out that the healthiest people usually have various sources of satisfaction: they are doctors, say, but they are also spouses, parents, friends, citizens, churchgoers, art lovers, stamp collectors, golfers. Work is not the only prop to their self-esteem.

Cardiologist Meyer Friedman of San Francisco, co-author of *Type A Behavior and Your Heart*, says many workaholics want status and their status depends on what other people think of them. Dr. Friedman and his cardiologist co-author, Dr. Ray H. Rosenman, divide the world into two working types. Hard-driving people are classified as Type A and low-pressure people as Type B. Both types can become work-

aholics, but in different ways. The Type A person is excessively ambitious and competitive, and frequently hostile; he feels pressured by deadlines. Cardiologists have found that he is two to three times as likely to have a premature heart attack as a Type B, who is not so competitive and hard-driving.

"Workaholics rarely become famous," says one New York psychiatrist who has treated many people with work problems, "because they lack creativity, they rarely make an original contribution to the welfare of mankind. They usually end up in upper-middle management, giving grief to everyone around them."

Says Dr. Edwin Boyle, research director of the Miami Heart Institute of Miami Beach: "The narcotic addict might get hepatitis from his addiction or the alcoholic contract cirrhosis as a result of alcohol addiction. From the standpoint of risk factors, the work addict is likely to develop coronary thrombosis."

Dr. Boyle believes that the workaholic's unique talent for self-deception will generally keep him from seeing the possible heart attack in his future. Normally, he goes blithely along until he gets struck down.

Phyllis Snyder, executive director of Chicago's Alcoholic Treatment Center, who has worked in alcoholism treatment

for some 25 years, concurs with Dr. Boyle and says: "A hard worker has plans and goals and works to achieve them. When he reaches a goal, he's ready to relax. An addictive worker has to keep busy and has no real goal except endless activity. He's probably frightened and insecure and runs to his job because there he can feel capable and get admiration. His critical need to be busy would keep him from seeing his plight until some kind of crisis, such as a heart attack or other illness, got his attention."

Hugh Sidey, a columnist for *Newsweek*, recently wrote a column called "A White House Workaholic?" Wrote Sidey:

"In legend, men are crushed physically and emotionally by the burden of the presidency. In real life, their cheeks get pinker, their stomach more relaxed, their spirits higher and their pocketbooks fatter. They go around telling people how good they feel and how much they enjoy the work. They find after years of nomadic campaigning they can sit down and eat dinner (Carter calls it supper) rather regularly with their families. Some Presidents were not all that thrilled at domestic reunification. But Carter indicates he is...

"It may not always be so smooth for
(Continued on page 60)

Inflation is still on the move! Now is the time to consider a home in Florida at a price you can afford!

A completely furnished 2 bedroom Perma-Mobile® home plus a 60' x 90' landscaped lot with Carport, Utility Room, Florida Room, Patio and Sidewalk included!

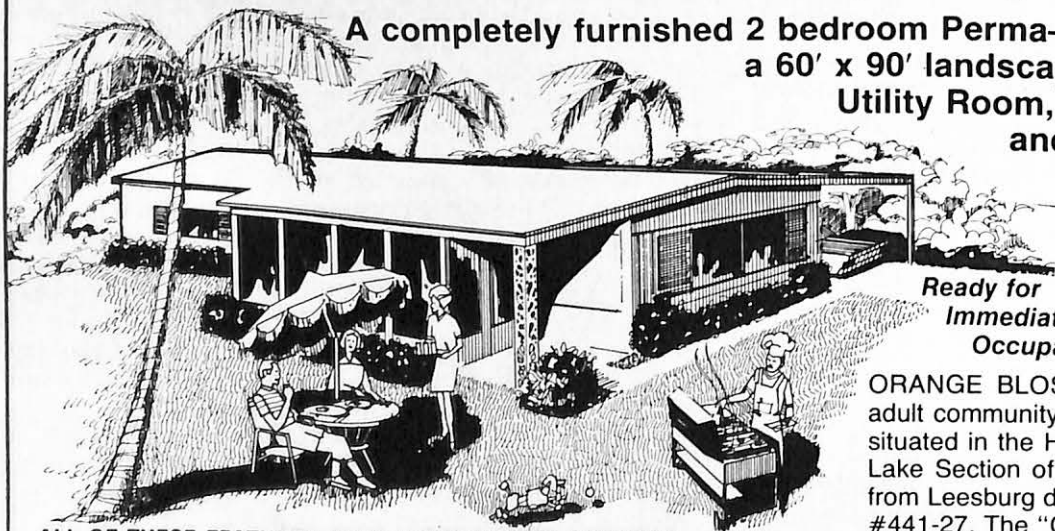

ALL FOR ONLY
\$19,995
BANK FINANCING

Ready for
Immediate
Occupancy

ORANGE BLOSSOM GARDENS, a friendly adult community of over 500 people, is ideally situated in the Heart of the Citrus Groves and Lake Section of Central Florida. Only 8 miles from Leesburg directly on 4 lane U.S. Highway #441-27. The "Gateway to Disney World."

For Information Call

TOLL FREE 800-874-9059
(In Florida call 800-342-9071)

Or write EXECUTIVE OFFICES

ORANGE BLOSSOM GARDENS Dept. 52-X

2148 N.E. 164th Street, Miami, Florida 33162

FURNISHED MODELS INCLUDING
DOUBLE-WIDES ON DISPLAY

Prices subject to change without notice

ALL OF THESE FEATURES HAVE ALREADY BEEN PROVIDED

- Security Police
- Free Bus Service
- Storm Sewers
- Wide Paved Streets
- Mercury Street Lights
- Corner Street Posts
- Garbage Collection
- Recreational Complex
- Heated Swimming Pool
- Underground Telephone
- Underground Electricity
- Outdoor Bar-B-Que Area
- Underground TV Antenna
- Central Sewage System
- Central Water Plant
- Private Lake on Property
- Full Time Social Director
- Driving Range

Not offered where regulated or prohibited.

**Senior Citizens Magazine award for the
outstanding Mobile Home Community of 1977**

"I lost 5 inches from my waistline..."

says Bill Parker

"...over 7 inches from my waist and tummy"

says Nancy Blair

ALL IN JUST 3 DAYS WITH THE MOST ASTOUNDING
Waist and Tummy Reducer

Astro-Trimmer™

GUARANTEED TO REDUCE YOUR WAIST AND ABDOMEN 4 TO 8 INCHES IN JUST 3 DAYS OR YOUR MONEY BACK!

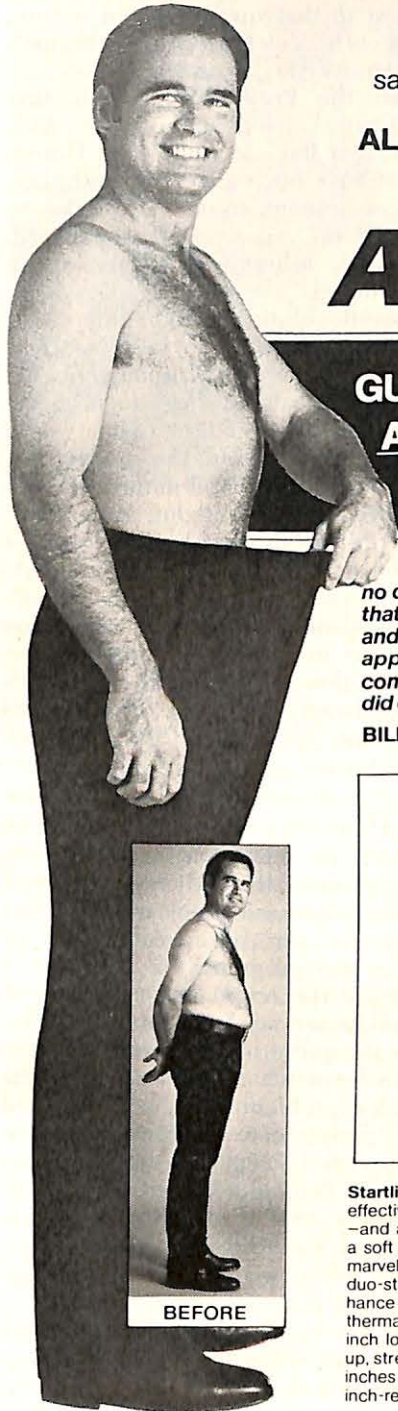

BEFORE

AFTER
Bill Parker... over 5" off waistline in just 3 days.

"... and it was a piece of cake—no diets, a simple ten minute program that got rid of the inches for good—and just look at the difference in my appearance! The inches have not come back—here is a product which did everything it promised—and more!"

BILL PARKER

"I wouldn't have believed the inches could come off so fast—4" off my tummy—over 3" off my waist in just three 10 minute sessions. It really shaped up my figure—I just couldn't be more thrilled!"

NANCY BLAIR



BEFORE

AFTER
Nancy Blair... her incredible results in just 3 days.

HERE IS HOW IT WORKS:



Bill wraps the Astro-Belt completely around his waistline, before hooking the Astro-Bands to a convenient doorway. He is then ready to perform one of the pleasant, marvelously effective Astro-Trimmer movements—just about 10 minutes.

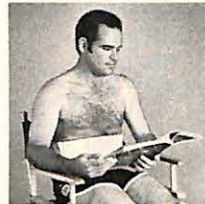

Now Bill simply relaxes a few moments with his Astro-Belt in place. His Astro-Trimmer movements have triggered the Astro-Belt's incredible inch-reducing effect which goes on working even as he relaxes.

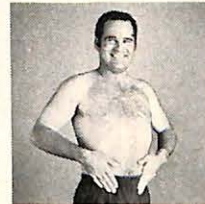

After his brief period of relaxation, Bill removes his Astro-Belt. His waistline is already tighter and trimmer. Bill lost 2 1/4 inches on his waistline the very first day—and over 5 full inches from his waistline in just 3 brief ten minute sessions.

Startling discovery—thousands of users are finding the Astro-Trimmer to be the most sensationally effective and the most fun to use slenderizer of all time. It is a marvel of ease, comfort and efficiency—and a pure joy to use. The Astro-Trimmer's totally unique design consists of a double layered belt—a soft nonporous inner thermal liner which wraps completely around your mid-section producing a marvelous feeling of warmth and support—and a sturdy outer belt that attaches you to the super duo-stretch Astro-Bands which you hook to any convenient doorway. These duo-stretch bands enhance your slightest movements and transmit their effect—greatly magnified—directly to the inner thermal liner of the belt to produce an absolutely unequalled inch-reducing effect. In fact, for sheer inch loss, the Astro-Trimmer is supreme. Try it for yourself—at our risk—just slip on the belt, hook it up, stretch and perform one of the easy-to-do movements in the instruction booklet and watch the inches roll off. Men and women from 17 to 70 are achieving sensational results from this ultimate inch-reducer. Results like these:

Laurie Jensen—"It was easy and so much fun. The Astro-Trimmer totally transformed my figure—took 3 1/2 inches off my waistline and 5 inches off my tummy in just 3 days—and best of all, the inches stayed off!"

Fred Masters—"No matter what I tried—dieting, exercise—I was never able to get rid of the roll around my mid-section. Then Astro-Trimmer came along and reduced my waistline 6 full inches—from 38 1/2 to 32 1/2 inches—in just 3 days without dieting."

Denise Dean—"Was amazed! After just 3 days on the Astro-Trimmer program I lost a total of 9 inches!"

How many excess inches can I lose with the Astro-Trimmer? How many excess inches do you have? Look what Bill and Nancy did in just 3 days. Many users lose 2 or more inches from their waists and 2 or more inches from their abdomens the very first day. Not everyone will do this. The degree of inch loss will vary with individual body response. However, this matchless body shaper melts excess inches off the waist, abdomen, hips and thighs with such amazing speed that **if your waist and abdomen aren't a total of 4 to 8 inches trimmer after using your Astro-Trimmer for just 3 days and if you don't lose these inches without dieting and in only 5 to 10 minutes a day, you may simply return your Astro-Trimmer and your money will be refunded.**

No risk—no obligation—money back guarantee. So-called "waist trimmers" and reducers are now being nationally advertised for as much as \$19.95 and more. Yet the sensational new Astro-Trimmer which trims and slims excess inches far faster, far more effectively than anything we have ever seen—is being offered for only \$9.95 with a complete money back guarantee. If you are not satisfied that the Astro-Trimmer is the fastest, the most effective waist reducer you have ever used, it will not cost you a penny. So if you want a trimmer, more ideally proportioned body—right now—send for your Astro-Trimmer today.

ORDER NOW FOR A SLIMMER, TRIMMER WAISTLINE THIS WEEK!

PAT PEND © Copyright Astro-Trimmer 1978 Highway 1 and Callendar Road, Arroyo Grande, CA 93420

Astro-Trimmer™ P.O. Box 3140, Dept. Ek-4, Monterey, Ca. 93940

Please send me Astro-Trimmers along with complete easy-to-use instructions. I understand that if I do not lose a total of from 4 to 8 inches from my waist and abdomen in just 3 days I can return my Astro-Trimmer and receive my money back. I enclose \$9.95 for each Astro-Trimmer plus 90 each for postage and handling. Check Money Order BankAmericard Visa Mastercharge

PLEASE CHARGE TO MY: Man: Waist Size _____ Exp. Date _____
Name _____ Woman: Waist Size _____
Address _____ City _____ State _____ Zip _____

WHERE THE ACTION IS

More and more,
Americans are
sounding off and
being heard



by Walter Oleksy

□ Americans always have been quite vocal about expressing their grievances. To attest to that quality of our nature, we recently celebrated our nation's 200th anniversary of independence.

When the President held his first "Call Carter" telephone question-and-answer "hot line" to the White House, he must have been aware of, and playing to, a growing trend in America to sound off on gripes and to be heard. Perhaps we inherited that need from our forefathers.

In pre-Revolutionary War times, citizens met at taverns to vocalize their grievances, or submitted anonymous essays on political injustices to a courageous newspaper editor who would publish them. Today the format for complaints of a political nature, and every other subject bugging Americans, is to write or call their local newspaper or radio or television "Action" department.

More than a quarter of a million complaints or requests for information or satisfaction are submitted each week to the more than 500 newspapers throughout the country that run Action columns which welcome grievances and attempt to find solutions for them. Thousands more contact their local radio or television news department as more of the audio-visual side of the mass communications industry recognizes the vast audience appeal of these service programs.

To trace the origin and evolution of the Action service is to put your finger on the pulse of the average American, to learn what he considers to be his major problem right now. Behind his complaints may lie the solutions to problems that keep this country from working as it should, like a Swiss watch. Doubtlessly, that is why President Carter tapped into the Action system, to find out what Americans are most uptight about.

The Action movement, which is as American as apple pie, most likely began in Chicago in 1884 on the old *Chicago Inter-Ocean*, a daily paper that ran a question-and-answer column called "The Old Curiosity Shop." Readers wrote in questions and sought answers that were remarkably similar to those submitted by today's public. A sewer was always backing up and the city wouldn't admit to its liability. A used horse-and-buggy salesman was always bilking some unsuspecting customer. A house of ill repute was always blinking its red light across the street from some church or funeral parlor.

The *Chicago Tribune* took up the consumer gauntlet from the *Inter-Ocean* on January 2, 1911, when it introduced its daily gripe column, "The Friend of the People." It ran on the editorial page and became enormously popular,

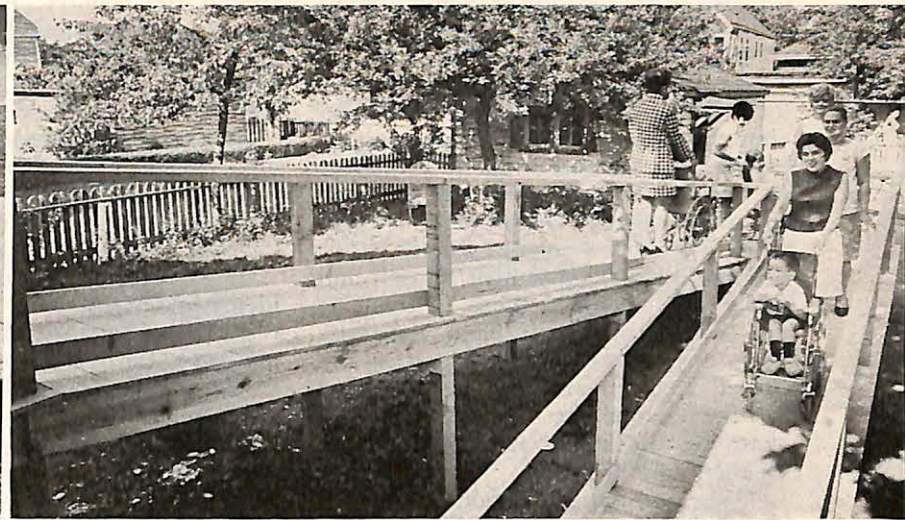

Before and after. Mrs. Macak had to maneuver four of her children in wheelchairs up and down the stairs (left). The ramp (right) was built with donated material by 45 carpenters and bricklayers with a little help from "Action."

though the majority of requests were for information rather than reflecting consumer complaints.

The late James Keeley, who was general manager of the *Tribune* when he introduced "The Friend of the People," suggested in the opening column that its purpose was to "aim to be a department in which information useful to the whole body of *Tribune* readers will result from answers given to questions relating to matters of public concern."

"The inalienable right of every American citizen is that of 'kicking,'" Keeley wrote. "Men of other nationalities pursue a *laissez aller* (unchecked freedom or unrestrained) policy when they think they are suffering from grievances. They say, 'Oh, what's the use' and proceed to drown their troubles in what they think is a substitute for consolation. But Americans believe they have a right to complain to some one."

"The Friend of the People" will, where it can, direct inquirers to official sources, point out laws and ordinances covering the matter in question, and refer seekers for information to the official whose department is concerned with the subject."

That preamble worked diligently for many Chicago area residents for many years, but served only as the groundwork for today's more aggressive problem-solving "Action" service. The modern "Action" newspaper column was the brainchild of William P. Steven when he was editor of the *Houston Chronicle* in 1961. His version of the public service question-and-answer column was more oriented to solving consumer problems and it soon spread to other newspapers across the country and around the world.

In London, Vienna, Hong Kong, and Buenos Aires you can open a daily newspaper and find an "Action" column that fields gripes from readers on subjects ranging from getting an overdue



unemployment insurance check to making a highway department reroute an expressway around your prized apple tree.

Even Russia has its "Action" column. *Izvestia*, the Communist Party daily newspaper, runs a column called "Ivan Ivanovich," which is the "Common Man's" name in Russia just as John Doe is in America. How it differs from American "Action" columns is amusing.

A Russian secretary of the Party's local office will write "Ivan Ivanovich" anonymously, snitching on a fellow worker that she is not working hard enough. A factory worker will write "Ivan" that some of the tractor factory's managers used the company truck illegally, to take them all to a championship soccer game in another city, obviously sour grapes because the complainant wasn't invited along.

Or a worker will put the finger on a bureaucrat by revealing that he took an unnecessary inspection trip to the Caucasus during the new wine season.

In most cases, "Ivan" will reply with reasons why something *can't* be done, or why a problem or complaint *can't* be solved.

Going to almost any length to solve a problem or get someone satisfaction is the bedrock of the modern "Action" column in America and the main reason why the service has not only hung on

but grown more widespread in recent years.

William Steven, now retired and living in Florida, tells how and why he started the first modern "Action" column in Houston:

"I came up with the idea to serve two purposes," Steven recalls. "It would be a place where readers could call in with problems, and also enable tipsters to give information that might lead to exposés and front page stories."

"For years, newspapers across the country had run 'Mr. Fix-It' columns, answering questions on how to repair things or where to turn for minor information or help, mainly about the home and property. Houston in 1961 was typical of many cities undergoing great urban growth when I was editor of the *Chronicle*. Many residents had moved there from other places and hardly knew the city. They didn't know where to go or who to ask about the problems that start to build up when a city is on the grow.

"It occurred to me that the *Chronicle* could perform a great service by running a column that helped solve some of these problems. And I figured that people are more likely to make a telephone call with a gripe than write a letter. So our column really began as a telephone number our readers could dial to phone in a complaint or ask for help on anything. The phone company helped us get a number that spelled the word 'W-A-T-C-H-E-M'."

"We started 'WATCHEM' on a Sunday and it was lucky we didn't pick a weekday. The volume of calls was so great, we tied up four Houston telephone exchanges!

"After four weeks of Sunday 'WATCHEMs', we ran six columns of questions and answers in the paper. Then it soon went into a daily feature. It became clearly the most popular feature in the *Chronicle*. I believe it was

because of the novelty of being able to call in and state your case.

"The basic success principle of the Action columns is: whoever is asking for help has to get results. It's not good enough to get a call from someone saying there is a lot of trash on the street in front of their house, and tell them to call the Street Department to clean it up. The Action column worker has to call the Street Department himself and make sure someone there is going to act on the complaint. Then you write your answer in the paper, after the Street Department does its job, and tell the complainer: 'The kids can roller skate on the street again. We got it cleaned up for you.'

"When a mother on welfare wrote us that her 6-year-old daughter was musically-inclined, but she was too poor to buy her a piano, we got the little girl a piano! 'Your request for a piano was satisfied yesterday,' we would write after arranging for delivery. 'We delivered it! That type of 'magic wand' reaction is very appealing to the public, which is used to red tape, frustration, or disillusionment.

"My only regret is, I never copyrighted the 'Action' idea! I'd have been a millionaire."

Steven admits, however, that he has enjoyed a million dollars worth of satisfaction knowing how his brainchild caught on, first in Houston and then

around the country. Editors of other papers heard about "WATCHEM" and soon came visiting the *Chronicle* to learn how they could adapt the column to their own newspaper and city.

Kenan Heise, editor of "Action Line" in the *Chicago Tribune* for the past four years, tells how Chicago newspaper editors quickly picked up on Houston's idea.

"WATCHEM" was a very good idea," says Heise, "but it needed a few refinements to really do the job. First of all, a better name was needed. When Luke Carroll and Lloyd Wendt of the *Chicago American* initiated the 'WATCHEM'-type column on October 3, 1965, they called it 'Action Line,' and I became its editor. It was the first time the word 'Action' was used for such a hot-line service, and it had great appeal.

"The second thing was, 'Action Line' aimed itself more at solving consumer problems. And instead of referring complainants to the Better Business Bureau, we confronted the bureau ourselves with the reader's problem and kept at it until we got an equitable solution."

The *Chicago American* later became *Chicago Today* (that paper folded in 1973) and Heise became editor of "Action Line" at the *Chicago Tribune*.

"In eleven years of being editor of 'Action Line' in Chicago, the column has fielded more than two million re-

quests and complaints," says Heise. "My staff of three other writer-reporters and two secretaries handle an average of 2400 requests a week now. Today the column is much more consumer-oriented and we answer *all* the questions and complaints.

"The column is constantly developing. We try to *clarify* what's wrong with a system or an industry, or a process such as mail order. We go into the background of why the Post Office is not responding to complaints. We're doing more secondary research, avoiding quick, snappy but shallow answers. This is a new direction that Action columns have to go, and I believe more of them across the country are assuming this sometimes awesome responsibility."

Heise tells about his favorite Action stories:

"A mother wrote us a few years ago that her son was in a mental institution. He had written to a Florida firm that advertised in a magazine for investors to put up \$100 for goods they would sell door-to-door for a nice profit. The young man got the goods but there was no way he could sell them, so his mother wrote us asking for help in getting a refund, since the firm repeatedly denied her requests. The firm told her it does not give refunds, and it told us the same thing. 'Action Line' finally

(Continued on page 36)

THE JOY OF GIVING

Elks National Foundation

2750 Lakeview Avenue • Chicago, Illinois 60614



Six new Foundation members received pins and certificates during National Foundation Night at Escondido, CA, Lodge. Chm. Monty Syrig (right) and Co-Chm. Harry Cowper (left) offered their congratulations and thanks to the Brothers.



An honorary founder's certificate and a heart charm were presented to Elks' ladies past Pres. Jean McClain (second from left) in recognition of the \$1,000 donation made by the Elks' ladies to North Las Vegas, NV, Lodge. Chm. Wayne Hiltbrand (second from right) made the presentation, while State Chm. John Motsch (left) and ER Robert Gonzales thanked Ms. McClain on behalf of the lodge.



Earl Lowry, chairman of Long Beach, CA, Lodge's rangers committee, David Sontag, and William Buschell accepted their participating member certificates at the lodge recently. The presentation was made by Treas. Floyd Beierle during a meeting of Long Beach Brothers.

How to Wake Up the Financial Genius Inside You In 1978

Millionaires Are Not 100 Times Smarter Than You, They Just Know The Wealth Formula

Millionaires are not 100 or even 10 times smarter than you, but it is a fact that millionaires are making 10 to 50 and even 100 times more than you.

Are these wealthy people working that much harder than you? No way!

If you are working only 20 hours a week, it would be physically impossible. (There are only 168 hours in a week, no one gets more.)

These questions used to really stump us. That was just a few years ago.

My wife and I then lived in Denver, Colorado, at 2545 South High Street. We paid \$135 a month rent for a cramped, tumbled down house. My wife was expecting our second child and we were flat broke. I felt desperate and forced into a corner. I had to borrow \$150 from my father and another \$150 from my father-in-law just to buy the groceries and pay the rent. If that wasn't enough, we were several thousand dollars in debt.

Things are much different now. Last year I could have retired and lived off the income of my one million dollars in real estate holdings. (Incidentally, almost all of the income from the real estate is tax free.)

Since I had worked 20 to 40 hours a week, I know that I didn't work even 10 times longer or harder than you. And with my C-average from Ames High School (located in Ames, Iowa). I did a little better later on but I soon realized that a salaried job was not the way to become financially free. If you'll stop and think, you'll realize that millionaires do not work 10, 20, or 50 times harder or longer than you.

If hours, efforts or brains are not what separates the rich from the average guy who is swamped with debts and very little income then what is?

I learned the answer to that question from an old fellow in Denver. This fellow worked in a drug store stocking the shelves. Very few people knew that he had \$200,000 in the bank, all of which he had earned starting from nothing.

Within a year after meeting him, I was told and shown the same thing by a young man who had recently earned over a million dollars. By this time, I began to realize that what I was being shown was truly a remarkable and workable way to grow rich.

I began to apply the principles and methods I had been shown. The results were



MARK O. HAROLDSEN
spent 4 years perfecting a "wealth formula" and became a millionaire in the process. More than 150,000 people have discovered how his methods can lead to their total financial freedom.

amazing. I couldn't believe how easy it was, in fact it seemed too easy.

But then I met an elderly lady (83 years old) who, although not very smart, has made \$117,000 using the same formula.

I then figured my beginning wasn't luck. For three and one half years, I worked hard to refine and improve on the formula that I had been shown, so that it would be easy to get quicker results.

As I did this, my assets multiplied very rapidly (160% per year) to the point that I didn't have to work any longer.

I guess I am bragging now, but I did start spending alot of time in our back yard pool, traveling around the country, and doing a lot of loafing.

Then one day a friend asked me how he could do what I had done.

So I began to outline the formula that I had improved to show him really how simple it was, and how he could do the same thing.

By the next time he approached me, I had written almost a complete volume on the easy way for him to copy my results.

I wrote this in simple, straight forward

language so anyone could understand it.

This time my friend's questions were very specific. (He had already begun buying properties with the formulas I had been giving him). Now he had a property he wanted to buy, but was out of cash. How could he buy it?

I not only showed him how to buy without cash, but by the time the deal was complete, he had \$5,000 cash in his pocket to boot.

I also showed him how to buy a \$26,000 property for \$75 down.

You, or anyone, can do exactly what I did, or my close friends have done, in fact, you may well do it better. (I began doing this in my spare time only.)

It doesn't matter where you live or the size of your town or city, my formula will show you exactly how to:

- Buy income properties for as little as \$100 down.
- Begin without any cash.
- Put \$10,000 cash in your pocket each time you buy (without selling property).
- Double your assets every year.
- Legally avoid paying federal or state income taxes.
- Buy bargains at ½ their market value.
- Allow you to travel one week out of every month.

When you send me a check or money order for \$10, I will send you all my formulas and methods, and you are free to use them anywhere and as often as you would like.

Now if you were a personal friend of mine, I know you would believe me and not need any kind of guarantee, but since you don't know me personally, I will guarantee that you will be completely satisfied and that my formula will work for you if you apply it. I will back up that guarantee by not cashing your check for 30 days, and if you for any reason change your mind, let me know and I will send your uncashed check back.

You may well ask, why am I willing to share my formula for wealth? Well, because many of you will probably seek further consultation and direction from me as your wealth rapidly grows and my consultation fee adds to my fortune.

But you shouldn't care if I profit as long as you profit. And I guarantee that you will.

By the way, if you feel a little uneasy about sending me a check or money order for \$10.00, simply postdate it by 30 days which will completely eliminate your risk.

REFERENCES

The Salt Lake Chamber of Commerce,
19 E. 200 South, Salt Lake City, Utah 84111.
Charles Huber, C.P.A., 1850 Beneficial Life Towers, Salt Lake City, Utah.
801-531-8286.

I HEREBY CERTIFY THAT ALL THE ABOVE STATEMENTS ARE TRUE AND FACTUAL TO THE BEST OF MY KNOWLEDGE AND THAT I HAVE KNOWN MARK O. HAROLDSEN FOR MORE THAN FOUR YEARS. DURING WHICH TIME HE HAS ACCOMPLISHED THE THINGS HE HAS INDICATED ABOVE.

BRUCE M. HALE — NOTARY PUBLIC

MARK O. HAROLDSEN, 4751 So. Holladay Blvd., Salt Lake City, Utah 84117.

(Upon request, a notarized signed statement will be sent to you, certifying all statements and the money back guarantee.)

(Mr. Haroldsen has lectured to many and varied groups on his methods and formulas, but never before now have all of these been available. They are now available through this ad, or at the place of his lectures.)

MARK O. HAROLDSEN, INC.
Tudor Mansion Building
Suite 101, Dept. G-200
4751 Holladay Blvd.
Salt Lake City, Utah 84117

Mark, I am sending you the \$10.00 only on the condition you guarantee the material you will send me and that you will not cash my check for 30 days. I can expect to receive your formulas within 10 to 17 days from the day you receive my order. If for any reason I change my mind and send the material back, you agree to send my uncashed check back to me immediately. Upon these conditions, here is my \$10.00.

For deluxe, gold embossed edition add \$2.00

Name _____

Address _____

City _____ State _____ Zip _____

2CC © Mark O. Haroldsen, Inc. 1978

30 DAY FREE TRIAL

SAME GUARANTEE APPLIES:

VISA

Master Charge

Card No. _____

Expiration Date _____

Inquire at your local bookstore for Mark Haroldsen's "How to Wake Up the Financial Genius Inside You."

LODGE VISITS

GRAND EXALTED RULER HOMER HUHN, JR.



Lock Haven, PA, Elks welcomed the GER and Grand Lodge officials to a banquet at the lodge recently. On hand for the affair were (from left) Est. Loyal Kt. Russell Council, Trustee Pat LaRosa, Past GL Committeeman Robert McCormick, Secy. Harold Pfaff, ER Lloyd McKeague, Est. Lead. Kt. Francis Pinelli, DDGER Sherman Coudriet, PGER E. Gene Fournace, GER Homer Huhn, Jr., Past Grand Est. Lead. Kt. H. Beecher Charmbury, William Eise-mann, mayor, PDD Harold Sweeney, SP C. Bennett Dry, Secy. to the GER James Ebersberger, and VP Richard McClure.



A key to the city of Bangor, ME, was presented to GER Homer Huhn, Jr. (second from left) by Councilman Lloyd Willey (second from right), while SP Louis Bligh (left) and SDGER G. Anthony Jones observed. Brother Huhn met with representatives of Maine's 18 lodges during his visit to Bangor Lodge.



Enjoying an afternoon lunch at Kokomo, IN, Lodge's new building were PGER Glenn Miller (left), his wife Barbara Miller (second from right), GER Homer Huhn, Jr. (right), and his wife Jo Huhn. The Huhns and the Millers later traveled to PGER Miller's home lodge in Logansport for the 90th anniversary celebration of that lodge.



During a meeting of the Michigan Elks, guest of honor Homer Huhn, Jr. (second from left) and PGER E. Gene Fournace (second from right), state sponsor, were greeted by VP William Murray (left) and SP William Bailey. GER Huhn joined the state Elks at the assembly hosted by Traverse City Lodge.



On the West Coast, the GER attended a meeting of Oregon Elks held in Salem. Grand Lodge dignitaries who met with GER Homer Huhn, Jr. (second from right) were (from left) Grand Est. Lead. Kt. Hal Randall, SP Ernie Zielinski, and PGER Frank Hise, state sponsor.

NEWS OF THE LODGES

Big Bear Lake, CA, Lodge recently hosted a distinguished group of Elks from the Los Angeles area, who attended a dinner and dance followed by a breakfast. DDGER Eugene Weigand of Pasadena Lodge and his wife Peggy were joined by dignitaries from the eleven lodges of Arcadia, Burbank, Canoga Park, El Monte, Glendale, Los Angeles, Monrovia, Reseda, San Fernando, Sunland-Tujunga, and Van Nuys.

District student aid scholarships for one academic year were awarded to five students sponsored by Waynesboro, PA, Lodge. DDGER George Pugh of Pennsylvania's South Central District was instrumental in the selection process and presented the scholarships.

The members of Kingston, TN, Lodge gathered with PGER Edward McCabe at the lodge's annual fish fry recently. Those who enjoyed the traditional event included PERs Tom Isom, Harry Wade, J. M. Allen, G. L. Garner, PDD and Secy. Howard Patton, and Brother Don Wallace.

A night of fun with games, puppet shows, and all the food they could eat was held for a group of exceptional children and their parents at Cambridge, MA, Lodge recently. The lodge entertainment committee dressed for the occasion in clown suits and enjoyed the evening festivities with the children.

A dinner given in honor of the city's midget football teams was held by Beatrice, NE, Lodge recently. All-American candidate Ken Spaeth was on hand to discuss his experiences as a Cornhusker team member. Following the program, Mr. Spaeth signed autographs for the youngsters near the entrance of the lodge.

Two memorable events occurred for Westwood, NJ, Elks recently. The lucky winner of Westwood Elks' 31st charity fair raffle, Mrs. Grace Hall, received a new 1977 car. Prompted by winner's enthusiasm, Mrs. Hall donated \$100 to the lodge's Crippled Children's Fund. The proceeds from the raffle were donated to Pascack Valley Hospital, Elks Camp Moore, and other charities. The Brothers were also pleased when Cub Pack and Scout Troop No. 295 presented their charter to the lodge. The troop is comprised of 22 handicapped youngsters who carry on the various traditional activities of Scouting.

Two birthdays were celebrated by

Elks in Wisconsin and New Jersey recently. A grand fete was held at Ashland, WI, Lodge to commemorate the 75th anniversary of the state association. On hand to toast the occasion were PGER Francis Smith, PER H. L. Perrin, and SP Charles Bergstrom. The Brothers of Ridgewood, NJ, Lodge were proud to wish Charles Coene a happy 100th birthday. Brother Coene has been a member for over 52 years and is the second centenarian to belong to Ridgewood Lodge.

A project undertaken by the Veterans Committee of Clearfield, PA, Lodge recently was geared towards aiding veterans at the VA hospital in Altoona. The Brothers sponsored fund-raising events, which included a western hoedown dance and a steak and fish dinner, in order to purchase 20 television sets for the veterans.

Southern Pines, NC, Lodge hosted a meeting recently which was attended by Elks dignitaries. SP Ralph Pitts presided over the assembly during which Treas. Herb Finck received \$7,700 from PGER John Walker for the Boys Camp operation, the state major project. GER Homer Huhn, Jr., who was a principal speaker, and SDGER Thad Eure were among those present. One of the highlights of the gathering was the presentation of \$11,308 to the GER for the National Foundation by the North Carolina Exalted Rulers.

Midget football players surrounded Cornhusker Ken Spaeth as he autographed pictures.



Cambridge, MA, party-givers

From 1964 to the present time, Brother Bill Gillingham of Lompoc, CA, Lodge has donated over five gallons of blood to the Tri-Counties Blood Bank. For his contribution, Brother Gillingham was honored by his lodge and received a life membership award from the Blood Bank.

Two new Elks of Culver City, CA, Lodge, Rex and Don Ashford, organized and financed a country-western dance recently. The proceeds from the event, totalling \$674, were donated to aid those who have cerebral palsy and to the building fund. Prize money won by Brothers Bobbie Brown, Wally Pollacci, and Jim Mullens was returned to supplement the charity funds.

Rumford, ME, Lodge held John Koris Night recently. SP Louis Bligh, master of ceremonies for the occasion, spoke about PDD Koris's dedication to the National Foundation. Others who gathered to honor the departed Elk included his widow, his two brothers Tony and Frank, and a number of Maine Elks dignitaries.



LEGAL documents were signed by (front, from left) Secy. Abe Robertson, Cliff Ferris, trustees chairman, ER Tom Sanford, and Brother Fred Fozounmayeh, restaurateur, effecting the lease of Monterey, CA, Lodge's restaurant. The lodge Brothers worked for one year with lawyers George Brehmer (back) and Brother Sandy Stewart in negotiating the terms for the operation of the lodge facilities.

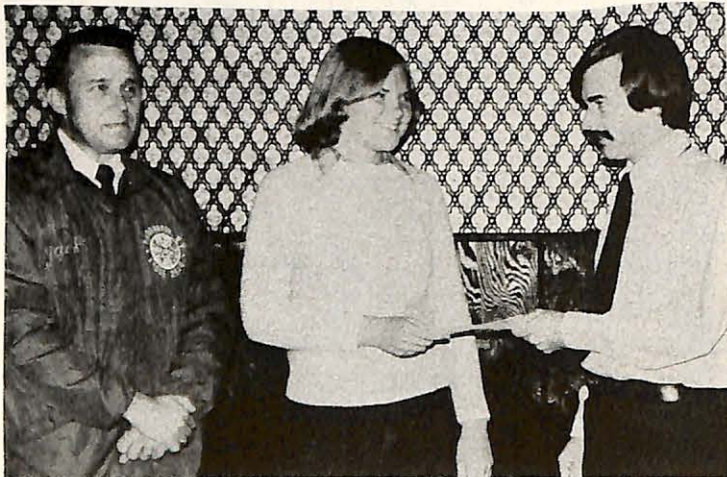

SCHOLARSHIP recipient Darsi Lee Jensen (center) accepted her \$1,085 award from Kinderhook, NY, Lodge Chm. Peter Goetchius (right), while ER Jack Savosky offered the lodge's congratulations to the young woman. Darsi has begun her studies at Oneonta State Teachers College.

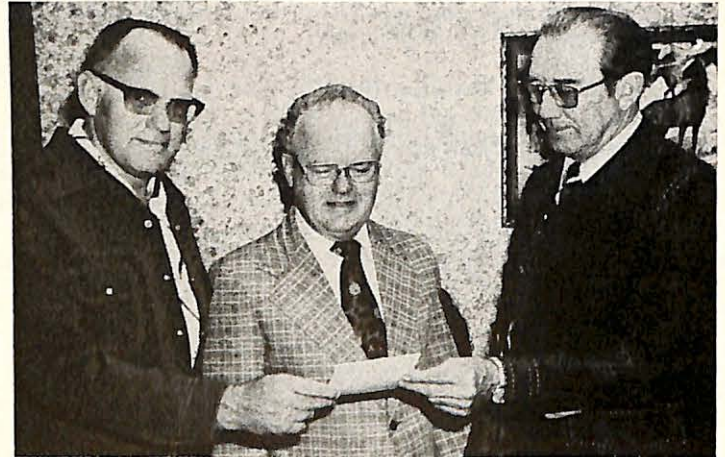

CALDWELL, Idaho, Lodge members recently contributed \$310 to a trust fund established for 13-year-old Ronnie Zehr, who was seriously injured when he fell into a hay chopper. ER Virgil Isaacson, Treas. Archie Stradley, and PER Merle Hamilton, vice-president and manager of the bank where the fund was established, checked over the account, which thus far exceeds \$6,000.



FOLLOWING initiation ceremonies which brought 27 new members into Scottsbluff, NE, Lodge and one member into Grand Island, NE, Lodge, ER Cork Brown (left) congratulated his son Rod, the new Grand Island Lodge Brother. The ER conducted the ceremonies during DDGER Delton Lamm's visit to Scottsbluff Lodge.



A CONGRATULATORY handshake accompanied ER Henry Kraus's (right) presentation of an American flag to Eagle Scout Timothy Perkins of Troop No. 387. El Reno, OK, Lodge sponsors the Boy Scout Troop to which the young man belongs.



HORSE LAUGHS and giggles recently greeted the Palo Alto, CA, Lodge clowns at a Horse and Fashion benefit show given for Stanford Children's Hospital. Thanking the clowns and expressing the lodge's support of the group, which visits children in hospitals and schools, was ER Al Raynal Sr. (standing, second from left).

A NATIONAL Foundation honor roll board and \$900 which completed payment towards his honorary founder's membership were presented by PER Leon Glowacki (left) to Chm. and PER John Dunder. The double presentation occurred during a Janesville, WI, Lodge meeting.



AFTER RECEIVING a flag and flag stand from Meriden, CT, Lodge during his homecoming visit, DDGER John Kuzmak (second from right) then presented it to ER Thomas Mauri (second from left) for use in the lodge room. On hand to read the base inscription, "Presented to John Kuzmak, DDGER Connecticut Northwest 1977-1978," were SDGER Arthur Roy (right) and PER and Esq. Frank Roccapiore.



MEMBERS and friends of Annapolis, MD, Lodge recently joined forces for the purpose of purchasing a \$15,700 bus, which is furnished with a wheelchair door, for the Providence Center School for Special Children. (From left) DDGER William Wilhelm, ER Kenneth Webb, Director Pat Hudson, PER and Chm. Earl Schellman, and William Clatonoff, a member of the Board of Directors, were on hand when the bus arrived at the school.



A PAPER DRIVE conducted by the Vets Committee of Gardena, CA, Lodge raised funds for the purchase of a remote control color television set for the residents of Wadsworth VA Hospital Center in Los Angeles. (From left) T. Kaye Miyamoto, assistant hospital director, accepted the check from Vets Chm. Ceceil Bardwell, while ER LeRoy Lander, Assistant Vets Chm. Roy Deaver, and Harry Tuthill, assistant voluntary service representative, observed the presentation.



AWARDS were presented to Boy Scout Arthur Smith (second from right) and Scoutmaster Harold Walthers (second from left) during the first annual Scouting awards dinner held by Keyport, NJ, Lodge. Arthur was honored as the Scout of the Year, and Mr. Walthers was commended for his seven years of service to the Scouting program and to Troop No. 230, one of two troops for handicapped youngsters sponsored by New Jersey lodges. Brother Joseph Young (left) and ER Thomas Fullerton made the presentations.



A YOUTH awards dinner held by Palm Springs, CA, Lodge brought together three of the Junior High Youth of the Month achievers, Terri Warfield (left), Melinda Bell (second from right), and Henry Brown (right). The youngsters received their awards and wishes for continued scholastic success from Youth Chm. Willison Schaefer (second from left), and ER M. C. Manthey on behalf of the lodge.



WHEN Nelson Stuart (left), executive director of the National Foundation, arrived in Michigan recently, he was greeted by State Tiler John Jensen of Ionia Lodge. Brother Stuart received a gavel from Brother Jensen, who has presented a gavel to each of the GERs who visited Michigan in the last eight years.



DDGER HAROLD Jacobson Jr. (left) was on hand for an initiation ceremony at Encinitas, CA, Lodge recently. The "GER Homer Huhn, Jr. class" introduced Gordon Brown (second from left), Robert Gadbois (third), and Chester Stewart (fifth) to the order. ER J. W. Sheridan (right) and Esq. Richard Taddiken were on hand to congratulate the new members.



THE INITIATION of Scott Greeno (left) was conducted by ER Everett Greeno (second from left), the new member's father. Also on hand for the ceremony at Wellington, KS, Lodge were Brother E. Jay Greeno (right), another son of the Exalted Ruler, and visiting DDGER Harlo Regier.



LONDON BRIDGE days were celebrated by residents of Lake Havasu City, AZ, recently with a week of revelry culminating in a parade. The local Elks entered a float, which was entitled "Sunset over Havasu," in the parade. Built and decorated by Lake Havasu City Lodge Brothers and the Elks' ladies, the float was awarded both "best of theme" and "sweepstake" trophies.



AN ANNUAL donation made by Massachusetts Elks to the Joseph P. Kennedy Memorial Hospital for children in Brighton, MA, was recently presented by (from left) PDD Robert Blomquist, PDD James Colbert, and PDD Thomas Donlan (right). Maria Petrelli, (seated, left) and Carol Walton (seated, right), who are patients at the hospital, joined Sister Lois Ann Van Delft, the director of nursing services, in thanking the gentlemen for the \$2,500 contribution.



PRESQUE ISLE, Maine, Lodge initiated a class in honor of DDGER Adjutor Pare (third from left), who made a recent visit to the lodge. Greetings were extended to the guest DDGER by (from left) Edward McNeal, Calvin Hussey, Bill McDivitt, ER Leonard Porter, Shirrel Vanover, and Roderick Grove.



A PLEDGE for \$7,500 to the Community Hospital of Schoharie County, Inc., Operation Update Fund is well on its way to being paid in full. The proceeds from a dinner-dance held by Cobleskill, NY, Lodge were presented by PER and Secy. Ransom Evans to Lewis Wilson, chairman of the hospital fund committee and a Past Exalted Ruler of the lodge. The \$1,722 check brought Cobleskill Elks within \$2,422 of their pledged amount.

AN ELECTRIC razor, one of four donated by Rio Rancho, NM, Lodge to Albuquerque VA Hospital, was given by Vets Chm. Henry Bagley (left) to Ms. L. Bushmiller, chief of volunteer services. The Rio Rancho Elks have also presented a television set, a portable radio, two wheelchairs, and 17,000 magazines for the use of the residents of the hospital.



The Snooze Quartz Alarm

For The Man With A Calling

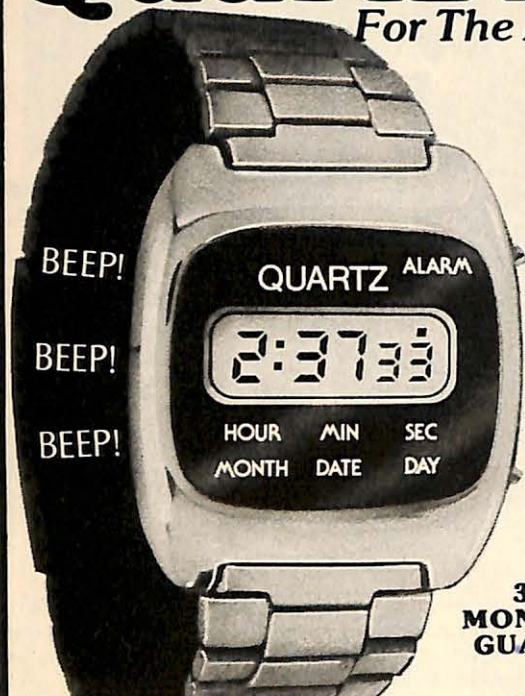

Credit Card Orders
Call Toll Free: 800-323-2272
Ill. Residents Call: 312-595-0461

- LIQUID CRYSTAL DISPLAY
- MULTI-FEATURED
- READ HOURS-MINUTES-SECONDS CONSTANTLY
- READ MONTH-DATE-DAY
- SEE PRESET ALARM TIME
- THINNEST ALARM WATCH AVAILABLE
- A MAJOR STEP IN SUBMINIATURE ELECTRONICS

**30-DAY
MONEY-BACK
GUARANTEE**

\$59⁹⁵ Lowest Priced Electronic Snooze Alarm Ever Offered

The most critical advance in time measurement -- when time is that critical commodity.

The Contemporary Quartz Alarm...for that singular man who recognizes the worth of a moment. 6-Digits, constantly on display, show Hour, Minutes and Seconds at a glance. Touch the button once to read the Month, Date, and Day of the Week. You can set it to catch the train. Make that overseas call. Visit your client. Make that lunch date. The Alarm sounds right on your wrist.

IMPECCABLE STYLING

In total contradiction to the powerful feature package and extra large display capacity of the Quartz Alarm, is its incredibly thin styling. Subminiature integration, the microscopic solid state science of the seventies, is wrought to its fullest. There is simply no slimmer alarm watch available. Its designer crafted face with complementing adjustable metal bracelet makes it the perfect accessory for you or a special friend.

EXTRAORDINARY PRECISION

The heart of our Quartz Alarm is a quartz crystal possessing the unique characteristic of emitting a beat not unlike your own heart-beat. The finer the cut of the crystal, the more precise its oscillating frequency. Our crystal is so fine that accuracy is assured to within one minute a year!

PERSONAL ALARM

In 24 hours there are 1440 minutes...and you can set your Quartz Alarm precisely to anyone of them. A tiny dot located just above the seconds tells you that the personal alarm has been activated.

BRIEF REMINDER SNOOZE ALARM

At the exact minute you previously set the alarm, an audible electronic BEEP will sound. A brief pause follows, allowing you to shut it off. If not deactivated, the personal alarm will follow through its full alarm cycle, beeping for 15 seconds and then will automatically shut itself off. If pressed once before the full beep cycle has sounded, the alarm will automatically sound again in 5 minutes. In short, it is a fascinating pause alarm that gives you 5 extra minutes before signaling you again. This delay period can be repeated over and over again. There is even a backlight which ensures perfect visibility during evening wear.

©CMI 1977

HERE'S HOW EASILY THE QUARTZ ALARM WORKS



CONSTANTLY READ:

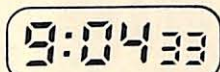

PRESS MODE KEY ONCE TO READ MONTH-DATE-DAY:

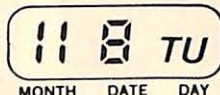

PRESS MODE KEY TWICE TO READ PRESET ALARM TIME:

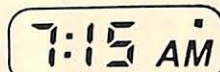

The square dot above AM or PM tells you the alarm is set.

It is a snap to operate. Numerals are so large and setting time is so easy that we want you to TRY IT NOT FOR 10 DAYS BUT FOR 30 DAYS...AT OUR EXPENSE! If you are not convinced that it is everything you expected, return it for a prompt and courteous refund. The Quartz Alarm Watch is backed by a 6 month factory guarantee.

LIGHT YEARS AHEAD

The Quartz Alarm represents the finest solid state, precision electronic timing device available...at a Contemporary price that makes it the very best value anywhere.

Order Now for Guaranteed Delivery in time for gift giving.

Please send me _____ Quartz Alarm Watch(es) at \$59.95 each. Check Color Preference:
 Goldtone with matching link bracelet (Item 0062)
 Silvertone with matching link bracelet (Item 0063)
 (Add \$2.00 per watch for shipping and handling.)
 Check or M.O. Enclosed (Ill. Res. add 5% sales tax)
 Please Charge My Credit Card:
 American Express Mastercharge Carte
 Bank Amer./Visa Diners Club Blanche
 Credit Card No. _____
 Mastercharge Bank No. _____ Exp. Date _____
 Name _____
 Address _____
 City _____
 State _____ Zip _____
 Signature _____

ELK-032

Contemporary Marketing Inc.

790 Maple Lane, Bensenville, Ill 60106

Call Toll Free
800-323-2272
Illinois Call:
312-595-0461

It's Your Business

(Continued from page 6)

is that Americans, although they approve of our economic system, have many negative attitudes and also a large amount of misunderstanding," the Ohio educator adds. "To cope with the economic system, to improve it, to change it, and to appreciate the role of many business institutions within that system requires education. Sound objective education, I am convinced, is to the benefit of the businessman and it will result in better attitudes and a healthier atmosphere in which business operates."

That's where Professor Vredevel and Ohio's Center for Economic Education play a part. The Buckeye state has seven centers and a statewide council on economic education which are already involved in the task. "The principal objective is not to educate educators about American business and businessmen. Our focus is on how our system operates. When one realizes the complexities of the economic system and this knowledge is based upon a real understanding of basic economic principles, the role of a particular institution within the system will be better understood. To simply talk about American business would be incomplete, I think.

"I believe that with such an understanding there will be a real appreciation, too, of the role of business today and the constraints under which it operates. The dynamics of supply, demand and competition among businesses go a long way in explaining to educators the importance of business and its responsiveness to the individual consumer. Furthermore, an understanding of competition and its effect on profits will show that within a competitive industry, for example, business cannot exploit the public and continue to conduct a profitable operation."

It's so obvious, it seems, but it's actually overlooked when seeking answers to the myriad of problems that face businessmen. Such advice, Roden says, is more practical than many realize. "In my own area, for example, companies can do much more to educate the public to their problems. When people perceive insurance companies they often see these multimillion dollar edifices and annual reports that show the millions the companies made. People cannot understand why the same companies say they are losing money or need to increase premiums. Big firms have to do a better job of showing people why, in fact, they are losing money; the societal attitudes that are causing it, for instance. It can't be done by a handful of executives or a trade association either. I think it extends from the president to the people in the field."

Will education and more communication help the businessman's image? What do you think?

Address your comments and questions to John Behrens, c/o The Elks Magazine, 425 Diversey Parkway, Chicago, Illinois 60614.

It Comes In Buckets . . .

by Jerry Hulse

If you arrive in Samoa any time between December and the middle of March, almost surely it will be raining. It comes down in buckets. Obviously, this was the season Somerset Maugham jumped ship in the harbor at Pago Pago. Why else would he have titled his classic short story "Rain"? To be perfectly frank, Pago Pago would have been better off if they'd never given his heroine, Sadie Thompson, the boot. Maybe Sadie Thompson did corrupt a missionary, the Rev. Mr. Davidson. But wasn't it better than dying of boredom?

Samoans swear Sadie Thompson was real. They say she strolled off a ship one day carrying her windup Victrola, hips swinging. The locals point out the rooming house where she drank and played her Victrola and watched it rain.

While it was pouring outside, Sadie was pouring inside. They say she had a penchant for rum.

The old boardinghouse where she partied turned out its last guest several years ago. It's a market now. But

never mind. There are other watering holes. The Bamboo for one. The Seaside Garden for another. Customers gather at the Bamboo for the happy hour every afternoon between 4 and 6 o'clock when drinks are only 60 cents. Sometimes there's entertainment. Other times there's a fight. At the Seaside Garden the proprietor has scratched out the house rules on a blackboard next to the bar: First, no customer is permitted more than three drinks at a time; second, fighting is forbidden, although the rules are broken occasionally. (The Samoans love a good time!) The Seaside is a tin roof shack on the waterfront where mostly everyone drinks beer, although the specialties are Spam sandwiches and boilermakers. (Before the Navy shipped out apparently it left a big load of Spam.)

First a coaling station, Pago Pago later came under the administration of the Navy and afterward the Department of the Interior. Officials say they want tourists but without frills. No high-rise hotels or fast buck artists. As a result, all they have is a single hotel, the Rainmaker, whose double story wings contain 163 rooms. Another 25 are available in Samoan-style fales. Once

the Rainmaker was one of the snazziest hotels in the South Seas. The view from the dining room is still worthy of praise. Windows frame the harbor and Rainmaker Mountain—and the Sadie Thompson lounge pours (just as Sadie did) from morning till late at night.

The dining room serves what is described as a Samoan chief's breakfast: grilled corned beef hash patties, a poached egg, a slice of taro and boiled green bananas. In the evening they switch to the High Talking Chief's Dinner: chicken, taro, boiled green bananas and coconut pudding. Once the hotel operated boat trips for its guests. But one morning the skipper skipped town. Someone learned later he'd sailed off to Tahiti. (The South Seas lure men that way.) Now guests amuse themselves snorkeling in the bay or else sunbathing beside a swimming pool perched high over the harbor.

Before the new Rainmaker, only one hotel operated in Pago Pago. It was Mary Pritchard's Rainmaker Inn and it wasn't much of a hotel. The bed-

Rainmaker Hotel, Pago Pago



It Comes In Buckets

(Continued from page 23)

springs squeaked and the rain sounded like a rivet gun against the tin roof. But it was colorful. Whenever its 15 rooms overflowed, Mary created others by installing portable dressing screens in the hallways. As I recall, that's where I slept on my first visit—out in the hallway. It wasn't bad. I amused myself watching lizards crawl across the ceiling. (They were on patrol against the insects.) At Mary Pritchard's Rainmaker Inn guests ate whatever was set before them. Moreover, they mixed their own bar drinks. Later when it came time to settle up, Mary told them to make out their own bill. "Just don't cheat me," she warned. And no one ever did.

This was shortly after Pan Am began flying jets down from Honolulu. The Pan Am bird still comes in every morning at 4 o'clock. It's the big event of the day. Even at that hour crowds are out at the airport. We left Honolulu on a Pan Am jumbo the other evening shortly before midnight and when we landed at Pago it seemed the entire island was up.

We were on our way to western Samoa, but had decided to spend a couple of days in Pago. For one thing I wanted to see if it had changed, which, of course, it hasn't. Unless you count Soli's new restaurant on Rainmaker Bay. Soli's is operated by Samoan High Chief Soli Aolaolagi, who has tattooed arms and jet black hair and who used to cut hair in the U.S. Navy. Soli still owns a couple of barbershops in Pago but he leaves the barbering to others. The restaurant is his primary concern now. Old hands say it's the best in Pago. Certainly the swordfish is superb. So are the mahi mahi, the cioppino and the lobster.

Soli's business card gives his address as "Happy Valley, Samoa." This was where the Navy used to hang out, so Soli feels comfortable there. The full name of his restaurant is Soli's Amatasi Room. It's the "21" of the South Seas. At night a Tongan entertains on the ukulele. He is, indeed, the ukulele virtuoso of Samoa, the John Denver of Pago Pago. Dressed entirely in white and wearing dark glasses, he winds up his act by kicking off his shoes and plucking the ukulele with his toes. It's big stuff with the locals. The crowd screams. If they scream loud enough, Sione Aleki does an encore. Only this time he strums the ukulele with his teeth. It's not very sanitary, maybe, but it's musical.

Pago Pago is American Samoa, so after a few days we moved on to Western Samoa, which once was British. It is, they say, the birthplace of Polynesia. Now the tourists are moving in and the locals have put up a modern hotel. With fales the size of the Goodyear blimp, the Hotel Tusitala provides such amenities as hot water, frozen mai tais, air conditioning, Kleenex tissues and instant coffee. The bigger fales are used for recreation rooms, a restaurant, a bar and the reception. As for the guests, they are bedded down in 96 rooms, each one identical and each one equipped with refrigerator, wall-to-wall carpeting and plumbing that works so marvelously one can't help wondering if perhaps this is the *real* Samoa. Occupying the site of the old Casino Hotel in downtown Apia, the Tusitala is one of the slickest new hotels in the South Seas.

Driving in from the airport (it's nearly 20 miles from Falelo Airport to Apia town) Toyota and Datsun taxis rattle through dozens of Samoan villages. Tradewinds blow straight from the open fales, pigs cross the highway and

youngsters run naked to the sea. Wrap-around lava lavas are the dress of the day for Samoans who fish, gather coconuts, breadfruit and bananas.

While the local television station pipes pictures into the fales of "Dr. Kildare" and the "Hollywood Squares," the waterfront town of Apia still stirs memories of an old South Seas wall calendar. Samoans gather on the wide, storefront verandas and animals run the streets. Grocery shelves are heavy with canned corned beef from Australia, pigeons in wine sauce, curried chicken, passion fruit and Danish ham rolls.

Wandering along the waterfront the other day, I turned into Aggie Grey's. At a table beneath a banyan she and I visited, recalling old times. Aggie wore a muumuu along with shell beads and a huge smile and her eyes shone.

"I'm getting old," she admitted.

I shook my head. "You're looking for a compliment, Aggie."

"No, seriously."

The waiter poured us each a beer. I raised my glass. "Do you feel old, Aggie?"

She shook her head. "Well, no, not really, but one can't argue with the calendar."

The woman who has become a legend in the South Seas is actually 80 years old, although she looks more like a swinging 60. I can recall when chickens ran through the rooms at Aggie Grey's hotel and there was always a lizard on the wall. Aggie's was unsophisticated and colorful and genuinely friendly. It still is. Only now it has grown bigger. Instead of 10 rooms, Aggie rents out 108 rooms. Stalks of ripe bananas hang outside the doors and colored lights shine from the palms at night like Christmas bulbs. All remains right with the world when the rain pounds down on the tin roof and the air smells fresh and the heavens explode with thunder. Aggie's guests are Americans, Australians and New Zealanders, along with a few Europeans. Americans especially love Aggie's. They're at home in her hotel. Aggie opened the place with three rooms. This was before World War II. Then after the Marines landed she became the Hamburger Queen of the South Seas. She fed the Marines and she comforted them. At the same time her bankroll grew fat and Aggie began adding rooms. She also gave birth to seven children—four by her first husband and three by her second. Both are deceased, but Aggie, bless her, is alive with a lust for life that belies those nearly 80 years.

She smiled. "Another beer?"

"Why not," I said.

With that Aggie raised two fingers to the bartender and we settled back to continue our visit. ■

Citizen of the Year

To improve the image of Elksdom in each of the various communities, it is important that we select a citizen who has contributed in some special way to the growth and betterment of the community. By honoring such a person through the Citizen of the Year program, your lodge can demonstrate its active interest in the welfare and progress of the community.

Who has done an outstanding job in promoting local programs for young people, the elderly, or the underprivileged? Who has succeeded in attracting a new industry to your town or city, or encouraged residential development? There is undoubtedly a resident of your area whose service to the community makes him or her a deserving candidate for your lodge's Citizen of the Year award.

Select such a person and submit his or her name to Grand Secretary Stanley F. Kocur, 2750 Lakeview Avenue, Chicago, IL 60614. He will issue a suitably inscribed certificate that will be sent to you.

Plan an appropriate public ceremony and be sure to hold the award presentation before March 31, 1978.

Stanley Mascoe, Member
Grand Lodge Lodge Activities Committee

How to move up from a dull, dead-end job to your own exciting prestige business...



...some true facts from Ford Marsh,
President, Duraclean International

A Duraclean Dealership is an easy business to get started, either part or full time. It takes just a small investment . . . no overhead expense for shop or office, no experience needed. From the first week, you can see your business build and profits grow. And it's all yours! You're the boss!

This is the way so many hundreds of men have reached executive status . . . the higher level career that was always out of reach because they didn't have more education or professional training.

If you feel trapped in a routine job with little chance to move up to a more exciting, more promising future, you may have already decided to have a business of your own.

You may have checked into business opportunities, then were discouraged because they require a much larger investment than you can make. Or you'd have to give up the paychecks of your present job to put all your time into the business. And that could be a rough go till you started making money.

Not so with Duraclean. If you are accepted for a dealership, as little as \$1985 gets you started. And we have enough confidence in your success to finance you for twice that amount, with

no interest, no finance charge. You can start in spare time, add your business profits to job salary, so you increase your income and net worth as your business is building. Then, with these growing profits and a solid cash base, you can safely quit your job and be a full time business owner.

Sound good? It is good. Here's why. You have 7 exclusive services for the cleaning and care of carpeting and upholstered furniture, all on-location at customer's premises. You need no shop or office. Phone calls come in at home. Equipment fits car trunk until profits buy your first truck. As you hire servicemen, Duraclean furnishes and pays for their equipment, without limit.

National advertising helps bring you customers. So do recommendations from carpet mills, furniture manufacturers, editors of home magazines, local home furnishing stores and the Parents Magazine quality guarantee of your services.

And, with Duraclean services recognized as "superior", you are in the respected position of a true Specialist, with a higher price for your services, so your profits grow faster.

How quickly can you get started? How long does it take to learn the business? Many men, in a week, learn everything they need to know about the services, thanks to Duraclean's thorough training. And we give you the benefit of our 44 years of know-how in helping men and women build and manage successful businesses in 27 countries around the world. Our experienced executives are at your service for day-to-day guidance. We show you how to get customers, how to run your own business profitably and soundly for a rewarding lifetime career.

COUPON BRINGS FULL FACTS BY MAIL FREE. NO OBLIGATION, NO SALESMEN. If you'd like to know more, just mail the coupon for the free 24-page booklet that shows how you can build your Duraclean Dealership in spare time while continuing your salaried job. Then decide if you want to apply for a Duraclean Dealership.

No salesman will call on you. No obligation, no decision now, just information. Shouldn't you send for it today?



"I AM MY OWN MAN!"

. . . says Bob Dunkelbarger

"I always wanted to be my own boss and manage my own time. Even tho I went

back to school and completed 2 years of college, I could not get beyond being a machinist. The highest I could get might have been lead man if I kept trying for it. I could see only more years of the same, chained to a machine until retirement. Now, every day brings new and exciting experiences. I've eliminated the confines of a factory, got the boss off my back, and no time clock to punch. I can arrange my time to do whatever I want, have no one to answer to, plus I'm making more money! I have my own business, and I am my own man!"

Duraclean® International



8-32 Duraclean Bldg., Deerfield, Ill. 60015

PLEASE RUSH FREE BY MAIL your 24-page booklet and all facts about the Duraclean opportunity. Advise how I can start spare time, and how you help me build my own independent business. No obligation. No salesman will call on me.

Print Name _____

Address _____

City _____ County _____

State _____ Zip _____

Telephone: (area code _____) _____

Oh! the MONEY in Hanover shoes!



Put another \$200 in your pocket next month with a Hanover Shoe sideline as your extra moneymaker. And get a free pair of shoes while you're at it!

Show friends and neighbors how to save more than \$15 per pair on . . . dress shoes, casuals or work shoes. Top quality, fine leathers, over 200 modern styles to choose from.

Show the picture-selling Hanover catalog evenings, weekends, lunch hours. Don't sell. Let them buy!

Pocket your high commissions, wear your free shoes. FREE catalog and sales kit for 30-day no-obligation trial.

No salesman will call.

**MAIL
FREE TRIAL
COUPON**

- The Hanover Shoe, Inc.
- Dept. 2045 Hanover, Pa. 17331
- Please send catalog and sales kit for 30-day
- FREE TRIAL. I am under no obligation. No
- salesman will call.

● Name _____

● Address _____

● City _____ State/Zip _____

Select Your LOG HOME



Use your custom plan or select one of ours. Cedar or Pine Log homes, leisure homes, and cabins from \$3900. Plan book \$3.50. Dealership information pack \$5.

Wilderness Log Homes

Rt. 2-EM2D, Plymouth, Wis. 53073

Please send Dealership information pack \$5.
 Plan book \$3.50.

Enclosed is \$ _____

Name _____

Street _____

Town _____

State _____ Zip _____

SENIOR CITIZENS Florida Living You Can Afford

Mobile homes from \$8500.00. Lot Rent \$37.50 month. Retire at Beautiful Dogwood Mobile Park. Rated Three Star. Recreation Hall, Bingo and Laundromat.

Write Charles Boitnott, 1800 Boitnott Ln. Winter Park, Fl. 32789

MEDICINE AND YOU

by Larry Holden

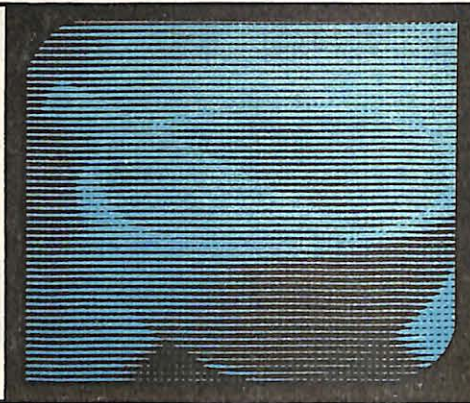

ATOMIC LIFE GIVING

Nuclear-powered people in real life are a far cry from the bionic fantasy of television's "Six Million Dollar Man." Most of them are older than rugged actor Lee Majors and the nuclear batteries in their chests are for the sole purpose of keeping their blood pumping, not super-human strength or incredible telescopic vision.

Small atomic batteries are space-age medical tools: power sources for troubled hearts. Designed to issue regularly-timed electric shocks, the nuclear pacemaker—like its conventionally-powered counterpart—is an emergency starter to make sure a person's life blood keeps flowing . . . and flowing.

The majority of people who need pacemakers are elderly. They are suffering from damage to the conduction system as a result of aging. The average candidate for a heart pacemaker is in his or her late 60s or early 70s. Some people have congenital heart blockages that don't become a problem until the individual is into the 30-to-50 age bracket. When a pacer must be implanted in someone only 30 or 40 years old, they face a lot of years with a battery in their chest. And since conventional mercury batteries last a mere two years, they face a lot of removal and replacement operations. About five percent of the pacemaker population is in this more youthful category and the nuclear-powered pacer was developed primarily with these people in mind, although the advantages of fewer operations for the elderly is also obvious.

The feasibility of nuclear pacemakers grew out of the space program, where atomic batteries were developed to gather data and send messages from distant planets. Even though the nuclear batteries used in space flight contain about 30,000 times more plutonium than pacemaker batteries, the materials, construction and basic technology is identical.

The application of atomic batteries to the world of medicine is indeed new, but the idea of sending electric shocks to the heart to make it pump was conceived more than 100 years ago. There was an electrical heart pacer prior to the Civil War. The device was, however, little more than an experimental curiosity in those days.

During the 1950s technology caught up with man's imagination and the first viable pacemakers were used—mostly on children who developed a temporary

heartblock during surgery. These pacemakers were worn externally and their power was supplied by plugging them into a regular AC outlet. These units were only temporary, they were used until the child's own heart recovered enough to take over its job again.

The next steps in the evolution of pacemakers involved making a pacer that was portable and then one that would be implantable. In 1960 Dr. William Chardack and Wilson Greatbatch, an engineer, developed the first pacemaker that could be implanted into a person's chest.

The only problem with these conventional pacemakers was the relatively short life-span of the batteries. Fortunately, the operation to implant a pacemaker or to replace a worn-out battery is not dangerous, but admittedly there is always risk when an operation must be repeated every few years.

So, out of necessity, the next critical step in pacemaker development was to increase the pacer's battery life. The first atomic pacemaker was implanted in the chest of a dog in 1969, and in April, 1972, Dr. Victor Parsonnet of Beth Israel Hospital in Newark, NJ, implanted the first nuclear pacer into a human. This breakthrough increased the time between pacemaker replacement operations from two years to an amazing ten years.

The atomic pacemaker is about the size of a pack of cigarettes and is encased in transparent, yellowish plastic. Inside the layer of plastic is the mechanism of the pacemaker—the small electronic device that shocks the heart into beating. Inside the plastic layer is also a capsule. Another, smaller capsule is inside that capsule and inside the second capsule is a third capsule. The central core capsule contains a few milligrams of Plutonium 238 and Plutonium 239, long-lasting nuclear materials that make the pacemaker pace.

Plutonium 238, which was chosen to power the pacer, is an intensely radioactive alpha emitter. Heat produced by the decay of this radio isotope is converted into electricity, which in turn is used to power a fairly conventional pacemaker circuit.

It takes about 0.4 gram of Plutonium 238 to keep a heart pumping. Nuclear pacemakers presently must be guaranteed for 10 years, allowing for a one-year
(Continued on page 38)

The American Bicentennial Collection

Latest Commemorative
To Our Nation's
200th Anniversary

HANDSOME
WALL DISPLAY!
PERFECT GIFT!

PLEASE ACT QUICKLY!
QUANTITIES AVAILABLE ARE LIMITED!

Striking presentation created by The Kennedy Mint especially to celebrate this landmark of American Independence.

Here's your golden opportunity to own a magnificent and valuable collection of historic authentic and replica coins. The collection is mounted and framed in walnut-finished wood with specially commissioned art and full description. Attention-compelling display you'll be proud to have on your office, den or living room wall. Ideal as gift for all occasions and all ages.

18th, 19th AND 20th CENTURY COLLECTION

30 handsome pieces that trace the history of American Coinage from 1776-1976 replica Washington penny, replica Continental dollar, replica \$25.00 Gold Piece of California Gold Rush days—authentic coins from old Indian Head penny to rarely seen Eisenhower dollar and genuine Silver dollar certificate plus many other valuable pieces. Painstakingly assembled and mounted in walnut-finished wood frame.

Only \$29.95 plus \$2.00 shipping and handling. Actual Size 16" x 13".

YOU MAY CHARGE YOUR BICENTENNIAL COLLECTION to your American Express, BankAmericard, Master Charge, Diners Club card account, if you wish. Charge or Cash. You're protected by The Kennedy Mint 15 day examination period.



CUT AND MAIL THIS COUPON TODAY!



THE KENNEDY MINT
1 Kennedy Square, Cleveland,
Ohio 44142

**CREDIT CARD USERS SPEED
DELIVERY BY PHONING TOLL FREE
800-321-1030 / IN OHIO, CALL (216) 433-4650**
24-Hours a Day . . . 7 Days a Week . . . INCL. SUNDAYS

YES! Please send me the Bicentennial Collection at price indicated at right. I enclose my check or money order payable to **THE KENNEDY MINT**. I understand if I am not completely satisfied with this collection I may return for full refund within 15 days.

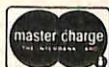

Bicentennial Collection at \$29.95 plus \$2.00 shipping and handling.
(Sorry no C.O.D.'s)



Please charge to: Visa
 Master Charge Bank Americard
 American Express Diners Club



Account # _____
Exp. _____

Name (Please Print) _____

Address _____

City _____ State _____ Zip _____

Signature _____

BE A LOCKSMITH



You'll EARN MORE, LIVE BETTER Than Ever Before in Your Life

You'll enjoy your work as a Locksmith because it is more fascinating than a hobby—and highly paid besides! You'll go on enjoying the fascinating work, year after year, in good times or bad because you'll be the man in demand in an evergrowing field offering big pay jobs, big profits as your own boss. What more could you ask!

Train at Home—Earn Extra \$\$\$\$ Right Away!
All this can be yours FAST regardless of age, education, minor physical handicaps. Job enjoyment and earnings begin AT ONCE as you quickly, easily learn to CASH IN on all kinds of locksmithing jobs. All keys, locks, parts, picks, special tools and equipment come with the course at no extra charge. Licensed experts guide you to success.

Illustrated Book, Sample Lesson Pages FREE
Locksmithing Institute graduates now earning, enjoying life more everywhere. You, can, too. Coupon brings exciting facts from the school licensed by N. J. State Department of Ed., Accredited Member, Natl. Home Study Council. Approved for Veterans Training.

LOCKSMITHING INSTITUTE
Div. Technical Home Study Schools
Dept. 1223-028 Little Falls, N. J. 07424

"Was never so enthused and delighted with lessons in my entire life. I grossed over \$3000.00 in one year just working weekends."
Rocky Orsi
Azusa, California



KEY MACHINE
locks, picks, tools supplied with course.



LOCKSMITHING INSTITUTE, Dept. 1223-028
Div. Technical Home Study Schools
Little Falls, New Jersey 07424 Est. 1948

Please send FREE illustrated booklet, "Your Opportunities in Locksmithing," plus sample lesson pages. I understand there is no obligation and no salesman will call.

Name..... (Please Print)

Address.....

City/State/Zip.....

Check here if Eligible for Veteran Training

GET RID of ULCERS FOR GOOD

AND ENJOY BETTER HEALTH

Medically-proven formula has helped thousands get rid of ulcers & digestive problems. You'll feel better & sleep better. Write today for FREE information. **Palafox-Knight Labs, Dept. BN2**
2311 Veteran, Los Angeles, CA 90064

WIN BIG MONEY IN OIL!
PLUS TAX BENEFITS

OTHERS DO EVERY MONTH IN U.S. GOVERNMENT OIL LEASE DRAWINGS. IF YOU ARE 21 AND A CITIZEN YOU CAN PARTICIPATE EQUALLY WITH MAJOR OIL COMPANIES IN THIS LEGAL LOTTERY. A \$20. TAX DEDUCTIBLE FILING FEE CAN RETURN UP TO \$75,000 AND MORE IMMEDIATELY PLUS A POSSIBLE FORTUNE IN FUTURE INCOME. WRITE DEPT E, FOR FREE INFORMATION.

Milligan Trust, 600 Manhattan, Boulder, Co. 80303

SILVER DOLLARS

5 (Different) Brilliant Uncirculated

SPECIAL \$59.99

Add 75c for mailing, postage, insurance and catalog. For catalog only, send 25c which lists all coins.

DEL'S INC. (E)

P.O. Box 81407, Lincoln, Nebraska 68501

PUBLISH YOUR BOOK!

Join our successful authors. Publicity, advertising, beautiful books. All subjects invited. Send for fact-filled booklet and free manuscript report.

CARLTON PRESS

Dept. ELB

84 Fifth Avenue, New York 10011

YOU AND RETIREMENT

by Grace W. Weinstein



LEGAL AFFAIRS

You probably have a family doctor and a dentist. But do you have a lawyer? You've probably consulted a lawyer if you've bought a house or drawn up a will, but most Americans reach retirement age without having a family lawyer. Yet there are many situations, especially at or around retirement age, that make legal advice worthwhile. You should consult a lawyer at the time of any major change in your life:

- ... if you move to another state;
- ... if you have a serious question about pension rights, insurance or social security;
- ... if you sell a house or buy one, if you move to a condominium or retirement community;
- ... if you remarry, and want to provide for both your new spouse and the children of a previous marriage;
- ... if you plan to travel, and be away from home (especially out of the country) for extended periods of time;
- ... if you enter into a contract of any kind;
- ... if you go into business for yourself, and must comply with license laws, filing laws, zoning laws, business tax laws, insurance laws, and more.

How do you find a lawyer, the right lawyer? There are several ways: Consult the local bar association, and ask if they have a referral service. Caution: most referral services do not list lawyers by specialty, and most do not comment on competency. Ask the advice of friends, but be sure the friends have received good legal counsel. Ask other professionals, real estate brokers or insurance agents or accountants. Caution: where the referring party receives a fee, the recommendation may not be in your best interest. If you work or have worked for a company that retains a lawyer, try to get his name; if he cannot handle your work himself, he can refer you to someone who will—and that person is likely to be competent. Similarly, "in-house" corporate or government lawyers, who cannot take on private cases, can be objective when it comes to recommending other lawyers. Law school professors and administrators, if they are in close touch with lawyers in private practice, may also be a source of suggestions.

The most important thing about the lawyer you choose is that you feel a sense of trust about sharing your private

affairs. The lawyer must be willing to talk, and to listen. You will want to interview your choice, therefore, before making a final decision. Most lawyers will meet with you, without charge, to get acquainted and answer your preliminary questions. Herbert Denenberg, former Commissioner of the Pennsylvania Insurance Department and author of *The Shopper's Guidebook* (Acropolis Books), suggests that you ask the following questions:

- ⊙ What kinds of clients do you represent? mostly individuals? or mostly businesses?
- ⊙ Do you have enough experience to handle any kind of case?
- ⊙ Who do you consult with on legal questions you're not sure about, and how often?
- ⊙ What's your specialty? If you're a general practitioner, will you send me to someone else if you don't think you can handle my particular problem?
- ⊙ Will you talk to me in plain English I can understand instead of using "legalese"?
- ⊙ Do you have any conflict of interest I should know about before I hire you?
- ⊙ How much personal attention will I get? Are you the person in the firm who will actually be doing my legal work?

If you have a particular problem, of course, you will want a lawyer skilled in that area of the law. If you are seeking legal counsel for a general legal "check-up," your concerns will be different. Either way, you want a lawyer you can trust, and a lawyer whose attitudes and philosophies are similar to your own. This may mean a lawyer close to you in age. It would probably not be wise, in any event, after going to all this trouble to find a lawyer, to pick someone who is much older; you may have to start all over again much too soon.

You will also want to know about the lawyer's fees, and should clarify them at this first meeting. Most fees are based on time, pure and simple, the amount of time your lawyer spends on your case: on the telephone, in person, preparing documents, researching the law, etc. You can reduce some of these costs by being prepared; when you call or visit, have all the necessary information at your fingertips. Have the information in writing. You might also request that work done by a legal secretary be billed at a lower hourly

(Continued on page 39)

Ten years before you
can take advantage
of this card,

you can
take advantage
of this one.



The day you turn 55 you can receive your AARP membership card. It's a card that can be important to you right now. Because once you have it, you're eligible for all the benefits and services of AARP.

What is AARP?

AARP is the American Association of Retired Persons. Non-profit, non-partisan and non-governmental, it's an association of over 10 million vital Americans. And one AARP membership of \$3* a year enables both you and your spouse to join them in taking full advantage of all AARP offers.

The New Social Security.

AARP is probably the only national organization in this country that offers people over 55 so many different and important ways to take full advantage of their age.

When you consider that all AARP's other benefits and services are yours to take advantage of, it's easy to see why our members call us the new Social Security.

The Advantages of Your AARP Card.

- Information about eligibility for Group Health Insurance coverage to

supplement Medicare or other basic health insurance.

- A Pharmacy Service that lets you buy the drugs and medical supplies you need at prices that average, according to a leading consumer magazine report, "only 2.9% above wholesale" and delivers them to your home, postage paid.
- Free educational materials on retirement planning, nutrition and health maintenance.
- Information on auto** and life insurance specially tailored for people over 55.
- 2800 Local Chapters where you can meet new friends and participate in community activities.
- Special programs on Consumer Information and Tax Aide assistance by IRS volunteers.
- The chance to find interesting part-time or temporary employment in a number of metropolitan areas through "Mature Temps" an AARP recommended service.

• The chance to strengthen AARP's Legislative Program which informs and advises legislators about the special interests of all older people.

- Special group travel tours and special discounts at leading hotels throughout the country.
- Subscriptions to our two special interest publications—Modern Maturity and the AARP News Bulletin.

Here's How to Take Advantage.

Wouldn't you agree that everything above is worth the membership dues? And there are even more benefits than we have room to tell you about here. The best way to discover them all is to join. It's as simple as mailing in the coupon. And there's just one requirement: you have to be 55 or over. After that, no matter what your interests are, AARP can make a meaningful contribution to your life..

*Membership dues include \$1.40 for annual subscription to Modern Maturity and \$.60 for the AARP News Bulletin.

**Only statutory coverage available in North Carolina, Texas and Massachusetts.

AARP
The new social security
for people 55 and over.

AARP American Association of Retired Persons 1909 K Street, N.W., Washington, D.C. 20049	
Gentlemen: I am 55 or over: Please enroll me as a member of AARP. I understand that it makes me eligible for all AARP benefits and privileges.	
Enclosed find <input type="checkbox"/> \$3 (one year dues) <input type="checkbox"/> \$8 (3 years dues) <input type="checkbox"/> Bill me later. DGX3	
Name _____	(Please Print)
Address _____	Apt. # _____
City _____	Birthdate _____
State _____	Zip _____
One membership makes both member and spouse eligible for all AARP benefits and privileges, however, only one may vote. Please allow 30 days for delivery of your membership kit.	

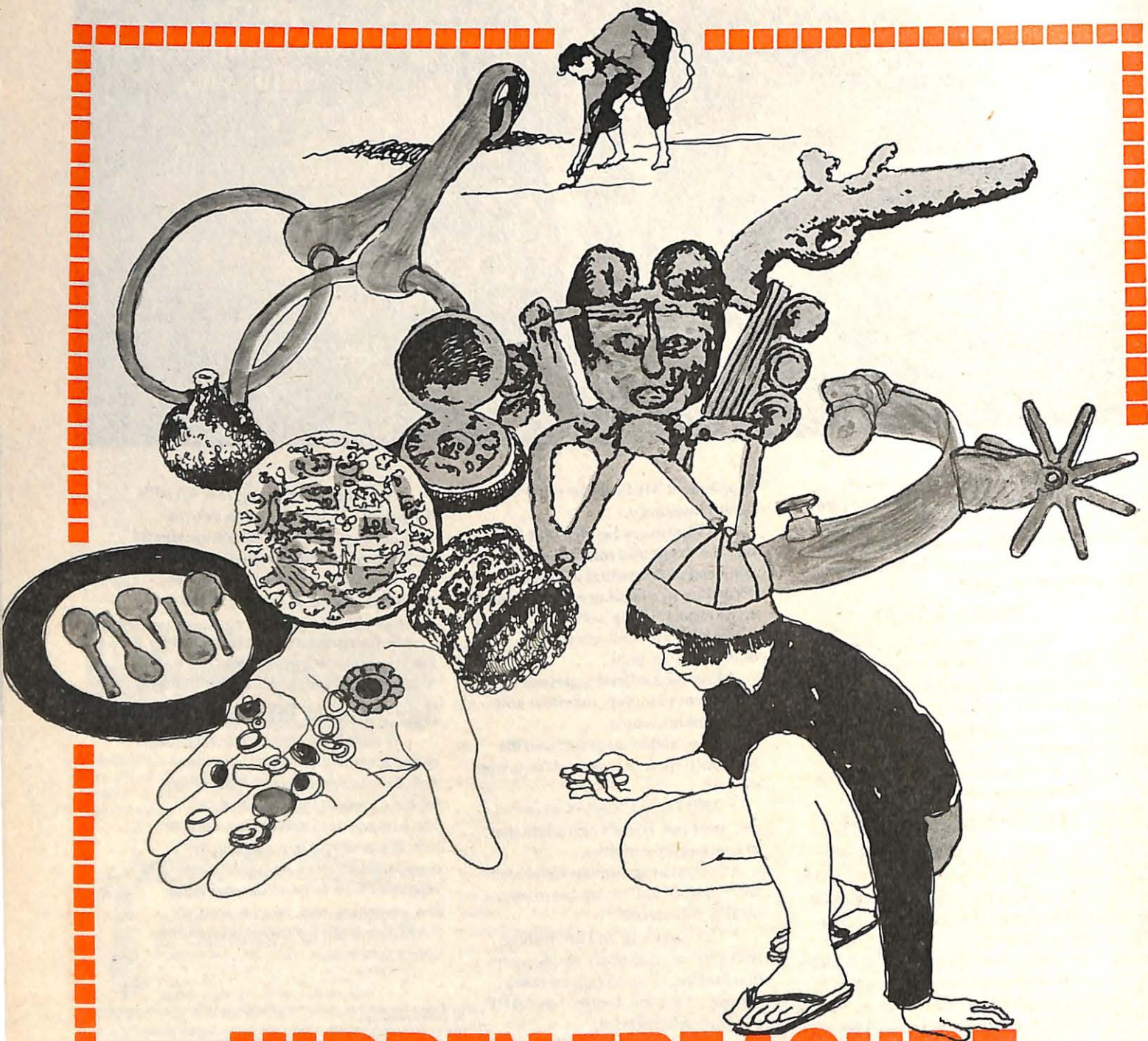

HIDDEN TREASURE IS EVERYWHERE...

AND YOU CAN FIND IT!

by Larry Holden

Thar's gold in them thar hills and money buried next to that rotting fence and a jar of coins hidden in your late neighbor's garden and valuable relics behind a board in that abandoned house and...

Billions of dollars worth of treasure have been hidden in every nook and cranny of the U.S. by Spanish conquistadors, gangsters (such as the infamous Dillinger) and the "ordinary" guy next door. This lost fortune is just waiting for someone to find it, and more than 250,000 people all across the country are doing just that. They're called treasure hunters and their quest is anything but a pie-in-the-sky venture.

A U.S. government office recently issued this statement: "The amount of lost treasure in the world is equal to ten times the value of all the wealth which is presently owned by all the people in all the nations of the world combined!" Professional treasure-hunters whole-heartedly agree.

"Participants in treasure hunting are unquestionably recovering a tremendous amount of 'lost' wealth," explains Charles Garrett, who is recognized as an international authority on electronic metal-mineral detection. Garrett, a designer of the seismograph planted on the moon by Apollo astronauts, is president of Garrett Electronics of Garland, Texas, a leading manufacturer of metal detectors.

"During the last 20 years," notes Garrett, "I've witnessed the growth of treasure hunting from the activities of a small group of professionals into an all-encompassing family hobby. And in the last ten years, because of advances in metal-mineral detection technology, hunters are locating more and more treasure."

Such treasure, valued at \$225 million to \$250 billion, was the goal of groups recently allowed access to White Sands Missile Range in New Mexico to search for the fabled Victorio Peak gold treasure.

Besides the obvious answer of gold, what exactly is treasure? It's anything that has a cash value or convertible value. This includes money in all forms, jewelry, guns, gems, heirlooms, genuine antiques, rare letters or books, skeletons, ration books, trading stamps, Liberty bonds, securities and just about anything not made or used anymore.

"Yesterday's trash is today's treasure," points out Ray Smith, founder and president of the National Treasure Hunter's

League, which has some 25,000 members in the U.S. and overseas. The league is both an organization and a business since Smith sells various types of metal detectors through its headquarters in Dallas, Texas, and through regional offices.

"Consider all the items that were common during the Civil War days that are extremely valuable now," adds Smith. "Bits and pieces of our American heritage—our roots—are worth money." One of his most valuable finds reflects our history. It's a 400-year-old Spanish coin found along a sandy stretch of beach just off the Texas coast.

Smith classifies treasure hunters in four categories: underwater explorers, those interested in relics, coinshooters and those seeking large caches. And every day treasure hunters in these categories cash in on a variety of situations.

Treasure hunters like:

Seth Hamilton of Sioux City, Iowa, has been coinshooting for about ten years. "I've located and uncovered over 100 pounds of coins, some worth several hundred dollars apiece, and about 300 gold and silver rings. Besides the obvious angle of finding money, treasure hunting is a fantastic means of relaxation for me. It's a great hobby."

Frank Angona and a friend's group discovered 180 silver bars buried in the floor of a cave near San Antonio, Texas. "Each bar was worth about \$100," confides Frank, who's been treasure hunting for some 30 years. "It was a nice find, but I've uncovered other big caches. I'm currently doing research on several out-of-state possibilities."

Ken Wray (and his entire large family) of Seymour, Indiana, discovered the riches nestled on an inland beach by being at the right place at the right time.

"We were at a local camping park with our detectors," recalls Wray, "when we noticed that a small lake at the park had been drained to increase the shore area. So my family and I decided to search in the drained section. I was wearing one of the outdoor chef's aprons with two pockets, and in no time I filled up the pockets with gold and silver rings and coins. Needless to say, we were surprised. We'd never thought that a beach would contain so many lost items."

"That weekend I found 35 wedding bands, class rings and other types of rings; the family ring total was 46. We

also found about 700 coins. From that day, beaches have been a prime target for our detectors. They're the places to look."

In seven years of treasure hunting Ken Wray says he's found more than 70,000 old and new coins. Naturally, the family total is much higher.

Joe Reith of Port Isabel, Texas, was dramatically introduced to the treasures hidden on an ocean beach.

"Back in 1962 my wife and I were living in north central Texas," explains Reith. "On a trip to Padre Island on the state's Gulf Coast we met a fella who had found three or four old Spanish coins made of silver by using a metal detector. We became interested enough to buy two detectors and plan a vacation trip back down to Padre Island. We really never expected to find anything; it was just a fun thing to do. I remember the people at work laughed at me when I brought my detector up there to show them. So we went on the trip—amid all the laughter."

"My wife and I decided to travel up and down the beach on a pair of portable motor scooters. Off we went, with our detectors in hand. The first day we didn't find anything. The second day I pulled up beside a large log, turned on the detector and—bingo! You know, I found one of those coins. It was a 2 Real. Then my wife found a 4 Real in good shape. Our hearts were pounding. We never imagined we would find anything so fantastic. Before the trip was over we found four 2 Reals and a 4 Real. We then were told a 2 Real is worth about \$50, if you can find someone to part with one, and the 4 Real would bring \$100 or more. From then on every time we could get off work we headed for the beaches. And when I retired six years ago, we moved to the Texas Gulf Coast. Now the beaches—and the lost jewelry and money—are extra handy."

Bernard and Laura Remke of Oklahoma often take extensive vacation/treasure hunting trips. On one recent three-month excursion they found more than 7,850 coins—including one large 1848 penny and a Morgan 1898 quarter—200 assorted rings, a jade necklace and many other valuable items. "Treasure hunting is healthy, and it keeps you active and young," says Bernard, who's now retired. "It is also very rewarding."

Kenneth "Rusty" Henry of Virginia Beach, Virginia, found more wealth in

the initial 30 minutes he "worked" his first beach than in more than a year of using metal on land.

"I was vacationing at a small lake in Kentucky," notes Henry. "I ran my detector along the sun-baked stretch of sandy beach and only found a few coins. Obviously, someone had worked the beach before with a detector.

"Then, looking out at the glistening water, I suddenly realized that a lot of people ski and play games in the water. So I stepped from the dry sand into the lake and put the water-proof coil of my detector into about two inches of water. Zap! The detector sounded and I pulled up a gold ring. In 30 minutes I found 11 rings—more than I'd found in the year I'd been using the detector!

"I found scores of coins and 32 rings that day. Before I left that summer I found 200 rings—including one with a 37 point diamond—in that single lake.

"I've been back to that Kentucky lake the last two summers and I've discovered 50 rings each time. People there are losing their jewelry at the rate of 50 pieces per season. So it's easy to understand, isn't it, why I love to work the beaches."

Rusty Henry wears an unusually designed, heavy signet-like ring that was made from nine of the gold rings he's

found. The ring is adorned with that 37 point diamond he found in Kentucky.

"When someone asks what I get out of treasure hunting, the ring is solid proof."

Metal detector expert Garrett pinpoints coinshooting as the most popular form of treasure hunting. "Because anybody can do it, anywhere—even in their own back yard. And it's a virtual certainty that a person can find coins if he looks in the right places."

The "right places" to search for coins or caches are as plentiful as the scores of intriguing accounts of such finds. A few of the places and stories are:

⊙ If you take a metal detector to the city park and search the grounds, you'll probably walk away with a handful of coins, some dropped years ago as children played and some dropped yesterday when a man dug in his pocket for change.

⊙ Ever hear of a "post hole bank?" Well, folks who didn't trust banks would often pull up a fence post, place cash or valuables in the hole and then push the pole back in the hole. If death came suddenly to the one who placed the money in the hole, the location of the "bank" was lost. Practically every day someone locates one of these banks. Not long ago, a Mason jar containing \$7,000 worth of pre-Civil War

coins and currency was discovered in a "post hole bank."

⊙ Coin hunters look carefully at trees near old houses. Rope marks on a tree branch mean that at one time a swing was there. And when you swing, you sometimes drop money out of your pockets. So . . .

⊙ Millions of dollars in money and bullion hijacked by train, stagecoach and bank robbers has never been found. Often the loot taken from such crimes was buried in the vicinity until things cooled off. Many times the outlaws were captured and hanged, and the location of their ill-gotten gains died with them. For example, the master bank robber of the 1930s, John Dillinger, hid about \$25,000 in the Oak Hills section of Indianapolis and on a beach at Daytona Beach, Florida. No one has found that money—yet.

⊙ Coin and cache hunters also find out where the garden was located at an old house and the spot of the chicken coop, if there was one. Why? Many elderly ladies, while pretending to work in their gardens, were actually burying jars of money for hard times. And a chicken coop was a perfectly logical hiding place. It had its own "built-in" burglar alarm.

So, what do you need to go treasure hunting? The primary thing is a good metal detector. There are currently three popular types of metal detectors.

The Beat Frequency Oscillator (BFO) detector is an all-purpose metal-mineral machine. When operating, the BFO emits a constant hum that speeds up when it detects metal and slows down for mineral. The BFO, with a full complement of search coils, is the only detector capable of performing all the phases of treasure hunting. It's excellent for locating gold deposits, as well as finding coins.

The Transmitter Receiver (TR) detector is the easiest to learn to use because of its simple tuning method and "quickness" of response. When operating, the TR's hum is barely audible. But the hum becomes louder whenever metal is detected. Not the best detector for mineral identification, the TR is ideal for coin, cache and relic hunting, plus building searching, beachcombing and general treasure hunting.

The discriminator or acceptance-rejection detectors use BFO circuitry and have a variable speed hum. Discriminators are capable of up to 95 per cent accuracy in "telling" the difference between desirable and undesirable objects. Undesirable objects include bottle caps, nails, gum and cigarette wrappers, beverage "pop tops" and small pieces of iron.

So what happens when you discover something valuable? The majority

(Continued on page 38)



In an electronic age, who'll ever make such clocks again?

The Original Schoolhouse Clock. Circa 1900. When They're Gone, \$110.00 They're Gone Forever.

Few Americans are lucky enough to own an authentic circa 1900 antique schoolroom clock—the kind that once ticked happily away in the front parlors, general stores and one-room schools of America's childhood. Now you can own just such a clock for far less than you could reasonably expect to pay for one at an auction or antique shop. Each is unique and in 100% running order. Yours will be numbered, registered to your family or whom ever you designate and accompanied by a hand—some Certificate of Age and Ownership (suitable for framing). Order now, to avoid disappointment.

Visit our Showroom, just 1 hour from N.Y.C.



PONY EXPRESS SYSTEM
2986 Navajo St. Dept. M-28
Yorktown, N.Y. 10598

Please send me _____ clock(s) @ \$110.00 plus \$6.00 for insured delivery of each. Please register to the name(s) attached. My check is enclosed for \$ _____ (N.Y. State residents add 5% sales tax.) We honor Master Charge, American Express, & BankAmericard. Include signature and appropriate data or for faster service call (914) 248-7031.

Mr./Ms. _____

ADDRESS _____

CITY _____ STATE _____ ZIP _____

Satisfaction Guaranteed

- Clocks, we believe, will appreciate many times in value in years to come.
- Certificate of age, authenticity, ownership.
- Fully re-conditioned 8-day keywind movement, brass pendulum, key. Counts each hour in deep melodic tones.
- Finely polished and carefully restored hardwood case, approx. 22" H. 13" W. 4 1/2" D.
- Sturdily cartoned and shipped to you UPS insured.

FOR FASTER SERVICE
ON CREDIT CARD ORDERS
call (914) 248-7031 9 A.M. to 5 P.M. (E.S.T.)

MAJOR PROJECTS

This is part of a continuing series on the state major projects. All state chairmen have been contacted by The Elks Magazine and have been asked to forward information for upcoming articles.

Throughout the state of **Maine**, in the parking lots of shopping centers and hospitals, and at state fairs and festivals, one may see a mobile home van with "Diabetes Detection Unit" printed across its side. With a closer look at the mobile unit, one will notice two emblems: those of the B.P.O.E. and the State of Maine Diabetes Association. The Brothers of Maine, the Diabetes Association, and other state medical associations combined their efforts to promote early detection of diabetes and hypertension.

The traveling detection unit has served over 2,000 people in Maine during this past year alone. Invested with modern technical equipment, the van is worth more than \$14,000, and with the anticipated growth of the program, it may be joined by a twin unit.

Each detection test costs, on the average, seventy cents. The Mainers who take advantage of the service, however, are not charged at all. The cost of the operation is met by the Brothers of Maine who hold various fund-raising events in order to support the traveling tester. The Diabetes Detection Unit plays an important role in the progress of preventative medicine in Maine today.

Thirty acres of woods and fields in the hilly **Vermont** countryside are maintained by the Vermont Elks Association, Inc., for the benefit of retarded children. Silver Towers Camp, located at the Ripton Work Center in Ripton, VT, has a social building, swimming pool, and horse corral for the children's exercise and enjoyment and a dining hall, sleeping quarters, infirmary, and maintenance building for their care and comfort. Although there is a state residency requirement, and the camp specifies "children," there are no age groups or limitations within that category, and there are no financial need limitations.

The program is operated by part-time professionals and volunteer Elks committeemen. They collaborate with other state and private agencies in running the camp.

All of the lodges in the state participate in raising money for Silver Towers. Among the statewide fund-raising projects is an annual Valentine's Day Party. From \$45,000 to \$55,000 per year is funneled from the Vermont Elks to the children's camp.

An occupational therapist employed by the **California-Hawaii** Elks Major Project, Inc. (CHEMPI) recently received a letter thanking her for her work with learning disabled children. The letter was from a teacher who noted changes in the children after they had been exposed to the therapist's sensory-integration therapy: "G. M. who suffers from extremely poor visual-motor coordination and attentional disabilities has improved 100% . . . S. W.



Jason Metz, a satisfied client of the CA-HI major project



Maine Elk's traveling detection unit

has recently completed second grade and his reading, writing, and behavior was as good as most of his classmates. Last year he could hardly write, read the alphabet, or sit still for more than a few minutes at a time." Day-by-day progress—taking the first step, or saying the first word—is the kind of miracle that 41 physical, occupational, and speech therapists work toward achieving with handicapped children from birth to 21 years of age.

Begun in 1950, CHEMPI's intention is "... to demonstrate its sensitivity to unmet needs of handicapped children by developing a program of supporting services to these handicapped children." There are three general aspects of the major project: 1) physical, occupational, and speech therapy for children whose needs can best be met by a home-based program, 2) a pre-school program screening for visual acuity, and 3) monetary support to assist unmet hospitalization needs of handicapped children at Elks Children's Clinics.

The project focuses on dealing with children whose needs cannot be met by other programs, and thus, must often send its therapists into rural areas, over logging trails and mountain roads. Mobile units transport the therapists, who operate within four Professional Services Divisions, traveling over 900,000 miles annually and providing 37,000 home therapy visits to children. The therapists advocate for their clients (patients), supervise therapy, work with the parents by teaching them to carry out prescribed exercise programs on a daily basis, coordinate and consult with other programs involved in the child's medical and educational background, keep themselves professionally aware by attending classes and seminars, maintain records on each child, present the project to Elks lodges and other organizations, and review the project in order to keep it professionally current.

The vision screening program is
(Continued on page 34)

manned by volunteers who test pre-school and kindergarten children, notify parents and school directors of their findings, keep records on all children screened, and receive and record findings of ophthalmologists and optometrists following

examinations. The major project also supports clinics at Children's Hospital in Los Angeles, Stanford Medical Center in Palo Alto, and the University of California Medical Center in San Francisco.

CHEMPI is headed by a Board of

Trustees which is appointed by the state association and serves as the policy making, structural design, legislative, and judicial body. Each trustee advises as many as 14 employees within the Professional Services Divisions. The executive director is under the direction of the Board and handles policies and administration of the major project. All employees are responsible professionally and administratively to the director of professional services, who is under the supervision of the executive director.

The Elks of California and Hawaii provide financial support for the major project, the yearly operating costs of which recently amounted to \$1,105,348. Almost all of the money comes from the Elks' Piggy Bank program, which is managed by a state chairman and vice-chairman, 17 district chairmen, and lodge chairmen in the association's 184 lodges. During the June state convention, the Exalted Rulers marched to the stage and delivered \$984,171 in voluntary donations. The per capita assessment taken from all Elks' dues was an additional \$166,805.

Fund-raising is a full-time occupation for California-Hawaii Elks, since they are the sole support of the project. Harness and motorcycle races, art and variety shows, and sports tournaments head the list of community events which the Brothers run and attend. Each lodge has its own Piggy Bank program and each member is given a Piggy Bank and asked to put "a coin a day" in the bank.

Thoughtfulness, time, and work are also part of the California-Hawaii Elks' contribution to the major project. When a therapist contacted a lodge looking for specially-cut boards for a testing kit project, one Brother donated the wood and one did the cutting. All of the small donations, in money or in labor, help a major project which helps the children. ■

Obituaries

PAST GRAND LODGE COMMITTEEMAN Clint Salyer of Chickasha, OK, Lodge died October 12, 1977. Brother Salyer was District Deputy Grand Exalted Ruler in 1965-1966 for the Southwest District, and in 1970-1971 he served on the GL State Associations Committee.

PAST DISTRICT DEPUTY Eldon H. Brown Sr. of Columbus, OH, Lodge died recently. In 1958-1959 Brother Brown held the position of District Deputy Grand Exalted Ruler for Ohio's South Central District.

PAST DISTRICT DEPUTY Harold M. Montgomery of Minot, ND, Lodge died November 2, 1977. In 1953-1954 Brother Montgomery served as North Dakota's District Deputy Grand Exalted Ruler.

PAST DISTRICT DEPUTY Jerry M. Kinvig of Mason City, IA, Lodge died November 27, 1977. Brother Kinvig was District Deputy Grand Exalted Ruler in 1968-1969 for the Northeast District.

FIND BURIED TREASURE

Find buried gold, silver, coins, treasures with powerful new electronic detector. Ultra sensitive. Penetrates deep into earth. Works through mud, beach sand, rock, wood, etc. Signals when object is detected.



Write for Free Catalog, treasure hunting tips and unusual souvenir coin.

Financing Available

RELCO Dept. DD29, Box 10839, Houston, Tex. 77018

Drill Your Own Water Well

50...100...200 Feet Deep.

SAVE HUNDREDS OF DOLLARS!



You can tap the vast, unlimited supply of good, clean, pure water beneath the surface of your property and have all the water you need for 2¢ per day.

What makes this possible is a remarkable invention called the Hydra-Drill. Amazingly, it is almost as easy and inexpensive to operate as a power lawn mower. In the last 10 years, thousands of people all over the world have drilled water wells with a Hydra-Drill.

If you want to know more about this wonderful way to drill your own water well and have a lifetime supply of chemical-free water for just pennies per day, then do yourself a favor. Send just \$1 for our big, fully-illustrated information package including complete instructions on "How To Drill For Water." The information package will be rushed to you by return First Class mail. Satisfaction guaranteed or your \$1 back!

Deeprook Mfg. Co., Opelika, Alabama 36801

CLIP COUPON AND MAIL TODAY!

Deeprook Mfg. Co. Dept. E28
Opelika, Alabama 36801

Enclosed is \$1.00 . . . Please send me the illustrated information package including complete instructions on "HOW TO DRILL FOR WATER."

PRINT NAME _____

ADDRESS _____

CITY _____

STATE _____

ZIP _____

© 1977, Deeprook Mfg. Co.

SENSATIONAL PURCHASE!



A. The Homestead in Winter

Copenhagen Blue

Decorative Porcelain Plates with Currier & Ives Winter Scenes

only \$3



B. The Farmer's Home — Winter

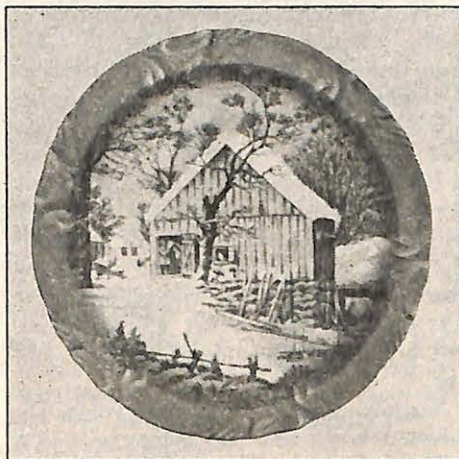

C. The Old Homestead in Winter



D. A Home in the Wilderness

Collectors love the distinctive color of Copenhagen Blue plates! And other collectors hunt through antique stores in hopes of discovering and buying a real Currier and Ives lithograph depicting America's all-but-vanished way of life in the last century!

Now we proudly offer a *rarity* — genuine Currier & Ives winter scenes, faithfully reproduced together with the original title of the scene on genuine decorative porcelain plates, in Copenhagen Blue. Each plate measures 8 1/8" in diameter and comes with a special loop ready for hanging. Think how they'll brighten your kitchen or dining room wall. Imagine how charming they'll look on a display shelf or hutch! The distinctive Copenhagen Blue, accented with white, goes beautifully with any decor, so order extras for gifts, too.

Order Quickly!

We predict our stock of these lovely plates will go fast. Mail coupon now to avoid delay. If not delighted just return within 14 days for full refund (except postage & handling) — so why not order and enjoy the complete set of 4!

Canadian customers, please send orders to:
Mail Store Ltd., Dept. UH, 312 Rexdale Blvd., Toronto, Ontario M9W1R6
(Ontario & Quebec residents add sales tax)

© 1977 American Consumer Inc., Caroline Rd., Phila., PA 19176

MAIL NO-RISK COUPON TODAY

AMERICAN CONSUMER, Dept. UH- 225
Caroline Road, Philadelphia, PA 19176

Please rush me the following Currier & Ives Copenhagen Blue Plate(s) at \$3 each plus 50¢ postage & handling.

— (#016) Scene A — (#024) Scene B — (#032) Scene C
— (#040) Scene D — (#057) Complete set of 4 only \$9.98
plus \$1 postage & handling.

If after receiving my order I'm not delighted, I may return it within 14 days and you will refund the full purchase price (except postage & handling).

SAVE! Order 2 sets for only \$18.98 plus \$2 postage & handling.

Total amount enclosed \$_____ PA residents add 6% sales tax. Check or money order, no CODs please.

On orders over \$6 you may **CHARGE IT!** Exp. Date _____

(check one) BankAmericard/Visa American Express
 Master Charge

BANK NUMBER _____

Credit Card # _____

Name _____

Address _____ Apt. # _____

City _____ State _____ Zip _____

8064

MOVING SOON?

Please let us know, as soon as you know what your new address will be. Be sure to supply us with both your old and new address, including the address label from your current issue. Copies we mail to your old address will not be delivered by the Post Office unless you pay extra postage.

ATTACH ADDRESS LABEL HERE

My new address will be:

NAME _____

ADDRESS _____

CITY _____ STATE _____ ZIP _____

Mail to: Circulation Manager
The Elks Magazine
425 W. Diversey Pkwy.
Chicago, Illinois 60614

Make \$15 An Hour
WITH YOUR OWN
SAW SHARPENING BUSINESS
1/2 the cost of other machines
• No experience needed - make money from the start.
• High profit - no inventory - no selling.
• Complete instructions & selling aids.
Sharpens hand, circular, carbide & chain saws.
Send today for FREE information - no obligation
TREYCO 325 Treyco Bldg., No. Tonawanda, N.Y. 14120
Phone: 716 / 693-6525
FINEST IN SAW SHARPENERS FOR 30 YEARS



FLORIDA'S WEST COAST
At \$21,900 a doublewide mobile home in a waterfront community can be your best Florida retirement housing value. For more information call toll free 1-800-237-2235 or write P.O. Box 340, Dept. 1247, Ellenton, Florida 33532.

LAPEL PINS
Fund-raising, Give-Aways, Membership Drives, Convention Swaps
YOUR DESIGN molded in 3 dimensions, rich colors. Choice of backs. Golf Ball Markers, Push Pins, etc. 1 1/2 to 1 3/4" dia. (min. 1000). plus 1-time mold charge. Free literature, or \$1 for samples (deductible on order).
KNOBBY KRAFTERS Dept. E
P.O. Box 300, Attleboro, Mass. 02703
Phone (617) 222-7272



**MODERN - OBSOLETE - FOREIGN
DOMESTIC - MILITARY - SPORTING**
WORLD'S LARGEST SUPPLIER
GIANT CATALOG #7
\$2.00 PDD
GUN-PARTS
NUMRICH ARMS CORP.
Box ELK, West Hurley, New York 12491

Where The Action Is . . .

(Continued from page 14)

got through to the firm owner's conscience and he agreed, most reluctantly, to give the young man his money back.

Joe Mann, like Kenan Heise, is a Chicago veteran of the Action columns. Mann has been editor of "Action Answers" on the *Chicago Daily News* for ten years. He and a staff of four helpers handle over 1000 requests or complaints a week.

"We're sort of a court of last resorts," Mann explains. "We get readers the satisfaction they would never get on their own. We think the column is both a lively feature for the paper and also a platform for informing the general readership. If they see how we have solved one person's problem, the public can follow our lead to solve its own similar problems. Sometimes, we are the only place a reader knows of to turn for help.

"One request we had recently was from the neighbor of a lady who has four children, all with muscular dystrophy. The neighbor explained how hard it is for the mother to help each child one-at-a-time down some high second-floor front steps in their wheel chairs, to get them out each morning to be picked up by a school bus.

"We brought the mother's problem to the attention of officials at the Chicago Building Trades Union. Forty-five carpenters and bricklayers came to the lady's rescue. They built her a ramp that wound up the rear of her house to her kitchen. Now she can easily roll her kids in the wheelchairs up and down the ramp. That was an example of how people in a big city really do care about each other. The union members donated their labor, while lumber and brick yards provided all materials free.

Mann's favorite over the years involves a boys' baseball game:

"Last summer, the late Mayor Daley's summer youth league baseball championship at White Sox Park for kids under age 12 narrowed down to two teams. A North side team of Puerto Rican boys and a South side team of Polish boys.

"Fans of the Polish team wrote 'Action Answers' complaining that the star pitcher of the Puerto Rican team was at least a head taller and three years older than the rest of the boys aged 12 and under. We looked into it, but it wasn't until the final day of the youth league's World Series that we found our answer.

"Our 'Action Answers' man on the story was a former Bat Boy for the Sox. He did some checking and just as the big game was about to get underway at noon, he dashed onto the field with evidence of foul play he had just found.

'Stop the game!' he shouted, and waved over his head papers that proved that the pitcher of dubious age was actually 15 and playing with his younger brother's birth certificate.

"The pitcher was disqualified, the game went on, the Poles won, and everyone was happy. Except, of course, the pitcher who was too old now to play with kids."

Chicago's third major daily paper, the *Chicago Sun-Times*, has run "Action Time" five days a week for a number of years and now its staff of four handles about 200 requests a day.

"Action Time," like many other Action columns across the country, runs a special additional feature called "Senior/Action," fielding questions of specific interest to senior citizens, appearing twice weekly. Other papers, such as the *Chicago Tribune*, run additional Action columns for ethnic groups, such as its Spanish-language "Action Rapida" column for Latino readers.

Anne Baumgartner, editor of "Action Line" in the *Miami Herald*, says the column has been running for 11 years and she and a helper handle 3,000 requests a week.

"We recently reunited a son with his mother after they had been separated for thirty years. She had been in the Navy and left him as an infant in the care of friends. Accidentally separated, we finally found her living in Massachusetts and arranged for her to fly to Miami to be reunited with her son.

"We also reunited a dog and his master, in one of our favorite cases. A man in Hollywood, Florida, had given his terrier to a dog show trainer who said he would take the dog on tour. But both the dog and the trainer vanished. Its owner wrote us for help and we turned to the Humane Society. They finally found the dog in Newark, New Jersey, where it had been left at the airport as unclaimed baggage. We had the dog flown back to Miami where its owner welcomed him like a long, lost relative.

"Our funniest case involved a request from a young man who was very much in love. He said that he wanted to impress his girlfriend on Valentine's Day by riding up to her front door in a suit of armor and mounted on a white horse. He asked for our help in finding the armor and the horse. We got both for him. He made good his intentions and arrived at her front door in his suit of armor, riding the white horse, but he wrote us afterward that he still didn't get the girl!"

John Castine's "Action Line" on the *Detroit Free Press* has been averaging 200 requests a day for the last ten years.

"One of our strongest points is, we name names," says Castine. "When

(Continued on page 42)

GIANT MURAL-SIZE Framed Color Portrait

Your
favorite
photo
enlarged
800%
IN FULL-
COLOR
only
\$298

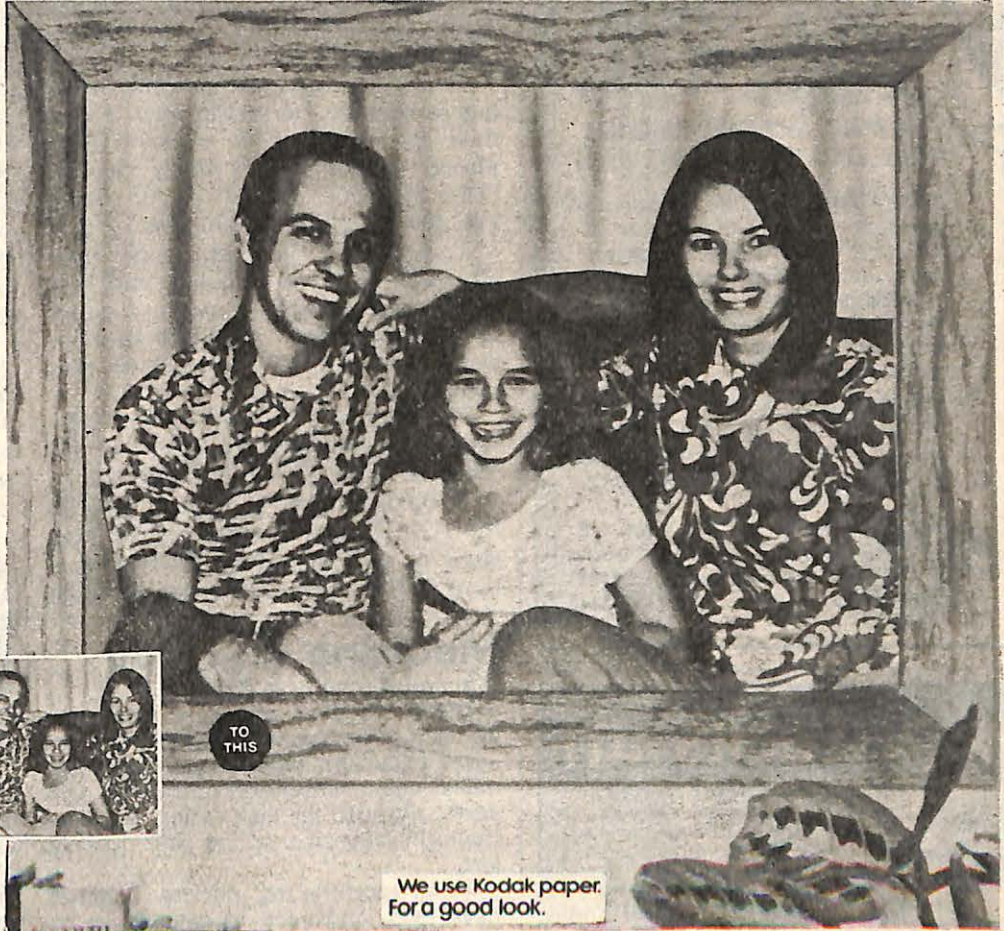

Including 'Wood Print' Frame

We use Kodak paper.
For a good look.

Now you can have a full-color portrait ENLARGED to a size rarely made by any photographic house or photographer. And it comes to you in a "wood-print" frame (simulated; wood printed on heavy stock) that sets it off strikingly with the rich look of walnut. A beautiful addition to your home. A treasured gift to send any loved one or special friend.

Hang it on a wall, where it will bring the beauty of a fine painting or prized print to any room decor. Or give your portrait a place of honor on a table, desk or bureau. (we include an easel)

A new, scientific break-through makes it possible to *enlarge*, with absolute fidelity and clarity, any photo, transparency or negative, to this new, mural size. You get all the beauty, all the vibrant colors so exactly that the fabulous portrait seems actually *better than the original!*

Any photo — color or black-and-white — can be used, and will be returned to you in perfect condition. Even a tiny 1 3/4 x 1" slide becomes a large 16" x 13" framed portrait, ready to hang, like a painting or art print, in a place of honor on your wall — or set on a table.

We'll even mail these handsome framed portraits for you to any list of people you want to send us. Please be sure to *print plainly* complete names and addresses of each person to whom a portrait is to be sent and print your

Bennett Graf, Inc., Inc. 1450 NE 123 St. No. Miami, Fla.

own name and address on back of each original photo to be returned to you.

We guarantee prompt shipment and complete satisfaction.

**BENNETT-GRAF, INC. Dept. 3575
1450 NE. 123 St. No, Miami, Fla. 33161**

Please send _____ (qty) New Mural Portrait(s) enlarged from the photo(s) enclosed. (When ordering Portraits to be sent to more than one person, enclose list of names and addresses on separate sheet.

I enclose payment of \$2.98 ea. plus 70¢ ea. to help defray postage and handling costs.

Total payment enclosed. \$ _____
(Fla. residents, add sales tax)

SEND TO: (NAME) _____

STREET _____

CITY _____

STATE _____ ZIP _____



**THOROUGHBREDS?
HARNESS RACING?
DOG RACING?**

**YES,
WE'VE
GOT IT ALL**

**TO MAKE ANY FUND-RAISING
OCCASION A FUN-RAISING EVENT!**

ARMCHAIR RACES is a complete film package — official programs, bet "money", mutual tickets, computer forms, daily doubles exactas and quinellas available — providing your members with thrilling races in vivid color with authentic track sounds and commentary.

Whether it's thoroughbreds, harness racing or dog racing, ARMCHAIR RACES is your best fund-raising bet! Write now for free detailed brochure.

Armchair Races
INC.

Dept. E-2
19-31 Mott Avenue
Far Rockaway, N.Y. 11691
(212) 327-2248

**\$300 a Week ... Now I'm a
FULL TIME LOCKSMITH**

"Because of a disability, I needed work that didn't require much physical effort. I investigated Belsaw, and now I'm working full time earning as much as \$300 in a week."

Tom Tipton — Covington, Georgia

Make up to \$10 an Hour — Even While Learning! Send for facts! Don't let age, education or a handicap stand in your way. Be your own boss in a business of your own. Learn at home in spare time. All equipment and supplies furnished. Special tools, picks and a pro Key Machine are yours to keep. Send for facts. Accredited Member NHSC.

No Obligation... No Salesman Will Call

**FREE BELSAW INSTITUTE
BOOK** 138F Field Bldg., Kansas City, Mo. 64111
Please rush FREE Book "Keys to your Future."

KEYS TO YOUR FUTURE

NAME _____
ADDRESS _____
CITY STATE ZIP _____

full details!

RUSH COUPON TODAY!

BINGO

Largest Manufacturer and Distributor of BINGO Supplies

Free Catalogues available for:

- ★ Complete bingo supplies
- ★ Tables & chairs
- ★ Flags & banners
- ★ Armchair races
- ★ Jar & breakopen tickets

ALL STAR BINGO INC. Dept. E-2
P.O. Box 2816, Clearwater, Fla. 33517
Toll Free Call 800-237-9885



Hidden Treasure

(Continued from page 32)

of treasure hunters operate on the premise of "finder's keepers; loser's weepers." Most laws pertaining to treasure point in this direction, although treasure trove laws vary from state to state.

Income tax regulations governing treasure hunting boil down to *all income derived from treasure hunting must be declared and all expenses (food, lodging, maps, equipment) required are deductible.*

"The thing that makes treasure hunting so exciting," says Garrett, "is that there is probably more treasure being placed in the ground today than is being removed. Money is still being lost. People still hide valuables."

Today, as in the past, people from all walks of life accumulate and hide money and valuable property. A roster of "treasure hidiers" would be an interesting and bizarre document, if ever compiled.

The health enthusiast, Bernarr Macfadden, might possibly head the list with a reputed, and very likely, \$7,000,000 hidden in various spots in the U.S. He told his wife he had large sums of cash buried at different locations so that wherever he was, he could

recover one or more of his caches in a short time.

Cyrus McCormick, credited with inventing the reaper, buried numerous caches in Virginia, Illinois and Wisconsin. Following his death in 1884, some of these treasures were found.

Many treasure hidiers are "average" citizens. Oscar Hastings of Columbus, Ohio, who often received hand-outs from his neighbors, died with about \$120,000 stashed in and around his humble home.

A long-time professional treasure hunter, Karl von Mueller, sums up today's treasure hunting situation. "There is treasure lost, buried or hidden in every county and parish of these United States and some of it is found every day. There has been an increasing amount of treasure found during the past few years, as more enthusiasts have begun to use more scientific methods in their efforts to locate it.

"If you will investigate some of the events of and people of your town, you will probably be surprised at some of the treasure leads you can turn up. In all probability, there is a treasure cache within easy walking distance of where you live or work."

Yep, podnah, thar's gold in them thar hills—and just about everywhere else! Get going, it can be yours. ■

Medicine and You

(Continued from page 26)

shelf-life. However, according to the people who make them, the power segment—the plutonium part—of a nuclear pacemaker could conceivably operate for 150 years, provided the lead casing, the electronic mechanism and the patient would last.

Until recently the nuclear batteries have been implanted in patients on an "officially experimental" case-by-case basis under highly stringent conditions. Not only must physicians who do the implants be licensed by the federal government, so must the hospitals and even the patients.

A few months ago the Nuclear Regulatory Commission announced official federal approval of widespread use of atomic power sources in heart pacemakers. Specific regulations for their use are still being formulated, however, since they contain radioactive material. Many requirements already exist and undoubtedly others will be added to the list.

Today Monsanto Research Corporation is a commercial producer of pacemaker power sources, supplying the atomic battery elements to companies that build pacemakers. "Putting together these sources is a science in itself," says Monsanto's Harold Coleman. "We have to encapsulate the isotope so it will be absolutely safe under any conditions, up to and including an accident that would kill the individual wearing the device." Coleman emphasizes that a nuclear pacemaker must still be sending out electric im-

pulses to the heart even if the individual were shot in the chest, run over by a train or involved in an airplane crash. "Even to the possibility that a person would die and the body be buried or cremated with the pacer still inside, that capsule still must maintain its integrity and contents." Usually, however, the nuclear-powered patient is kept track of and when he dies, the pacemaker is returned to the federal government.

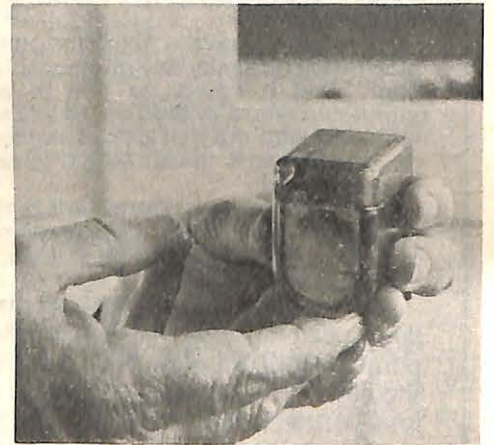

Nuclear powered cardiac pacemaker

Nuclear pacemakers are not likely to immediately take over the market, since they cost two to three times as much as the common mercury battery types. But according to a number of physicians and the common sense of fewer replacement operations, they unquestionably have their place in modern medicine.

Step aside, Six Million Dollar Man, the real nuclear-powered people are here. ■

FINE ELKS JEWELRY

PAST EXALTED RULER RING

6K solid gold ring. Raised head, perfect syn. ruby eyes. P.E.R. under emblem. B.P.O.E. carved on ring shoulder.
No. E-3069A, without diamond \$72.95
No. E-3069AD, with 3-pt. diamond \$96.25



MEMBER EMBLEM RINGS
Same as above without P.E.R. bar.
No. E-3026A 6K Gold \$69.95
Please specify ring size. Prices F.O.B. Chicago.

No. E-3028 Sterling Silver \$27.95

Past Exalted Ruler

Lapel Button
10K gold filled.
No. EB-2,
w/o diamond
\$8.25



No. EB-2D,
with 3-pt. diamond, \$31.55



Member
Lapel Button
10K gold filled.
No. E-81... \$5.35

No. E-81P, gold plated
\$1.90

Year Member
or Life
Member
Buttons

In gold plate,
5-50 years
or Life.
No. E-817GP... \$3.20



Elk of
the Year
Lapel Button
10K gold filled
w/o diamond
No. EY-1
\$9.65

10K gold filled w/diamond.
25 to 50 years or Life.
No. E817D... \$32.95

EY-1D with 3-pt. diamond
\$32.95

Jewelry with larger diamonds and quantity
prices on request.

SEND FOR FREE CATALOG

To serve you better, we have moved to larger,
more modern quarters.



RUSSELL-HAMPTON CO.
Dept. E, 2550 Wisconsin Avenue
Downers Grove, Illinois 60515
(A Chicago Suburb)

WIN BIG OIL MONEY
PLUS TAX BENEFITS
OTHERS DO EVERY MONTH IN U.S. GOVERNMENT OIL LEASE DRAWINGS. IF YOU ARE 21 AND A CITIZEN YOU CAN PARTICIPATE EQUALLY WITH MAJOR OIL COMPANIES IN THIS LEGAL LOTTERY. A \$20. TAX DEDUCTIBLE FILING FEE CAN RETURN UP TO \$75,000 AND MORE IMMEDIATELY PLUS A POSSIBLE FORTUNE IN FUTURE INCOME. WRITE DEPT. R, FOR FURTHER INFORMATION
MILLIGAN TRUST
600 Manhattan, Boulder, CO 80303

**COOPERATE
WITH THE
ZIP CODE PROGRAM
OF THE
POST OFFICE DEPARTMENT
USE
ZIP CODE NUMBERS
IN ALL ADDRESSES**

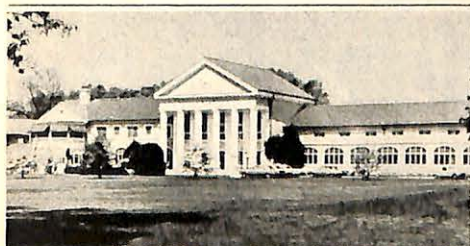

THE ELKS NATIONAL HOME

makes life worth living

For Full Information, Write

ELKS NATIONAL HOME
BEDFORD, VA. 24523

You And Retirement

(Continued from page 28)

rate than work done by the lawyer.

Some lawyers establish flat fees for particular services, such as drawing up a will or handling an uncontested divorce. Some lawyers, particularly in negligence cases where large amounts of money may be awarded, charge contingency fees; they collect a fee only if they win the case.

Lawyers' fees vary according to geographic area as well as service rendered; clients in urban areas generally face higher fees. However, the federal government has invalidated the minimum fee schedules which local bar associations used to establish as a matter of course. This means that shopping around for an attorney may save you considerable sums — if the person you select is the right person for the job. It also means, in some areas, that lawyers are beginning to advertise.

However you select your lawyer and whatever the basis of payment, Denenberg cautions:

- ✓ Remember that you hire the lawyer and he or she is working for you.
- ✓ Don't expect free advice. Time spent on the telephone is time which must be paid for.
- ✓ Don't expect simple answers to complicated questions.
- ✓ Don't withhold information or slant the things you tell him.
- ✓ If the lawyer is preparing a document, like a will or a contract, give him the facts and your wishes in writing. It will make his job easier and it will save you money.

✓ Ask for copies of all correspondence and documents prepared in your behalf. This way you'll know what's going on . . . and your lawyer will know you know.

✓ Keep your lawyer advised of all new developments.

✓ Insist on a complete, itemized bill. And reach a clear agreement about fees before the lawyer does any work.

✓ Put your agreement in writing; have the lawyer send you a letter setting forth the type of service he has agreed to provide and the actual or estimated charges.

✓ Where there is a contingent fee, insist that the lawyer's expenses be deducted before the fee is taken; otherwise the lawyer's expenses will come out of your portion of the amount recovered.

✓ Look into legal insurance and group legal services programs if you can.

For more information: The American Association of Retired Persons puts out a whole series of Retirement Guides, including *Your Retirement Legal Guide*. Any five of the guides may be purchased for \$1; membership in AARP is \$3 a year. For information, write to NRTA-AARP, Retirement Guidebooks, P.O. Box 2240, Long Beach, California 90801. ■

Address your questions and comments to G.W. Weinstein, c/o The Elks Magazine, 425 West Diversey Parkway, Chicago, Illinois 60614. Questions of general interest will be answered in a forthcoming column; Ms. Weinstein regrets that individual letters cannot be answered. ■



Why is Cuesta-Rey #95 America's largest selling 50¢ cigar?

ANSWER:

- Made of all Natural Leaf tobacco
- Made of selected imported long leaf filler.
- Rolled with aged rare Cameroon English Market Selection Wrapper (ACW®)*
- Skillfully crafted in Tampa by cigar makers in the same tradition of quality since 1884.
- Hand packed with aged cedar in natural wood cabinets.
- Also hand packed in gold and black packets of 3 cigars with exclusive polyethylene liners to assure long lasting factory freshness.
- Choice of smokers who are accustomed to the taste and aroma of fine imported leaf.

Send for the special offer today so you too can soon enjoy the fine quality CUESTA-REY #95 cigar.

*African Cameroon Wrappers

50c each. Natural wood cabinet of 50 — \$22.50.†
Cabinet of 25 — \$11.50.

Offered only by selected tobacconists

Actual size
6 1/4"

† Prices are approximate and subject to state and local taxes

SPECIAL OFFER

Traveling Man's
HUMIDOR

(Limit — one to a Smoker)

Holds up to 10 large cigars — perfect for traveling. Order now and we'll pack it with three 50¢ Cuesta-Rey #95 English Market Selection all natural leaf cigars and send it to you for less than the price of the cigars alone. Send coupon and \$1.00.

CUESTA-REY
ALL NATURAL LEAF CIGARS

Dept. EL-60, Box 2030, Tampa, Fla. 33601
Enclosed is \$1.00. Please send my Traveling Man's Humidor packed with three #95 English Market Selection all natural leaf cigars.

Name _____
Address _____
City _____
State _____ Zip _____
Please print legibly — Do not abbreviate

NEWS OF THE LODGES

(Continued from page 21)



A GROUNDBREAKING ceremony marked the first step in the construction of Salina, KS, Lodge's new building. The Brothers who gathered at the rural setting just outside of Salina included (from left) Est. Lect. Kt. Bernie Ribordy, Secy. Forrest Pettey, Est. Loyal Kt. Jim Peterson, Esq. Wade Mountz, PDD and Treas. Howard Houk, Est. Lead. Kt. Neil Stephenson, and ER Ralph Meagher.

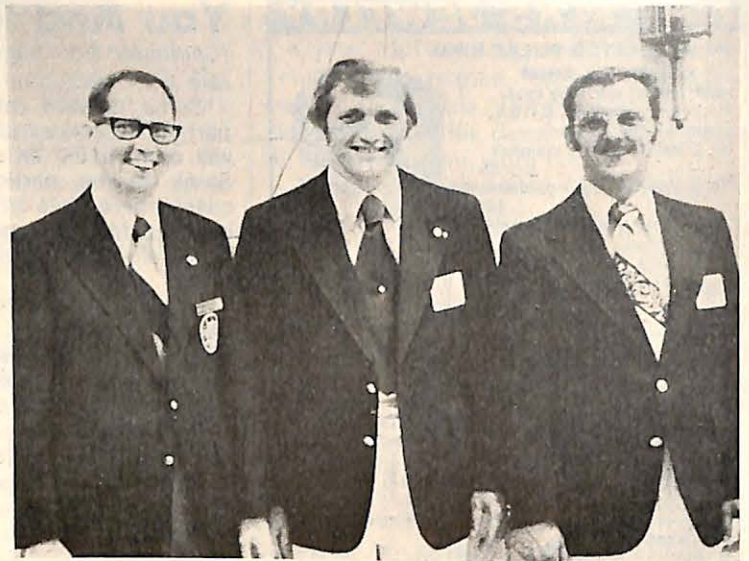

IN HONOR OF DDGER Donald Conrad (left) a group of 41 new Brothers was recently initiated into Meramec (Arnold), MO, Lodge. During the ceremony addresses were made to the class by DDGER Conrad, ER Donald Pusateri (center), and PERs Edward DaMeris, James Meyer, and James Pinson. The new Brothers and their friends and families joined DDGER Conrad, ER Pusateri, and Esq. Rich Neustader (right) at a luncheon after the initiation.



THE BROTHERS of Princeton, KY, Lodge gathered to celebrate the dedication of their new lodge building. Those who attended the affair included special guest PGER Edward McCabe (back row, third from left) and (front row, from left) Gene Butters and Woody Woodall, and (second row, from left) John Presler, Jim

Bob Kevil, Sam Jones, Ken Cortner, Don Reid, Gary Thompson, and (back row) Dennis Ryan, J. R. Hutchinson, ER W. D. Wadlington, SP William Stamps, Claude Kaltinsky, Van Knight, Charles Coleman, and Sam Rogers. An open house was held at the new lodge prior to the dedication.



ON BEHALF of New Braunfels, TX, Lodge ER Larry Rosser (front, left) commended the American Legion and Auxiliary, including (back row, from left) Richard and Martha Philebar, Cecil and Wanda Konkell, and Archie Culpepper, for their sponsorship of the Boys' and Girls' State programs. Mrs. Violet Ludwig received a certificate of appreciation from the Elks in recognition of the Legion's support of the Comal County youths.



FIVE NEWSPAPER carriers of the *Daily Record* in Wooster, OH, were honored at a dinner held by Wooster Elks during National Newspaper Week. PSP Floyd Shambaugh (right), who was once a *Daily Record* carrier, joined Est. Lead. Kt. Bill Cicconetti (left) in commending carriers (seated, from left) Jeanne Sands and JoAnne Biafore, and (standing, from left) Jeff Workman, Gail Wolboldt, and Jim Hercules, who also received trophies from the lodge.



MAJORITY LEADER Jerome Fitzgerald (second from right) of the Iowa House of Representatives was initiated into Fort Dodge, IA, Lodge recently. The new Brother was congratulated by Brothers (from left) ER Richard Ziems, C. Joseph Coleman, president pro-tem of the Iowa Senate, and DDGER Donald Tucker.



DURING a recent meeting of the West Central District of Illinois at Monmouth Lodge, SP Robert Carter (right) presented a National Service Commission award to PDD Marc Chapman of Galesburg Lodge. The plaque was an expression of commendation for Brother Chapman's dedicated work with veterans.

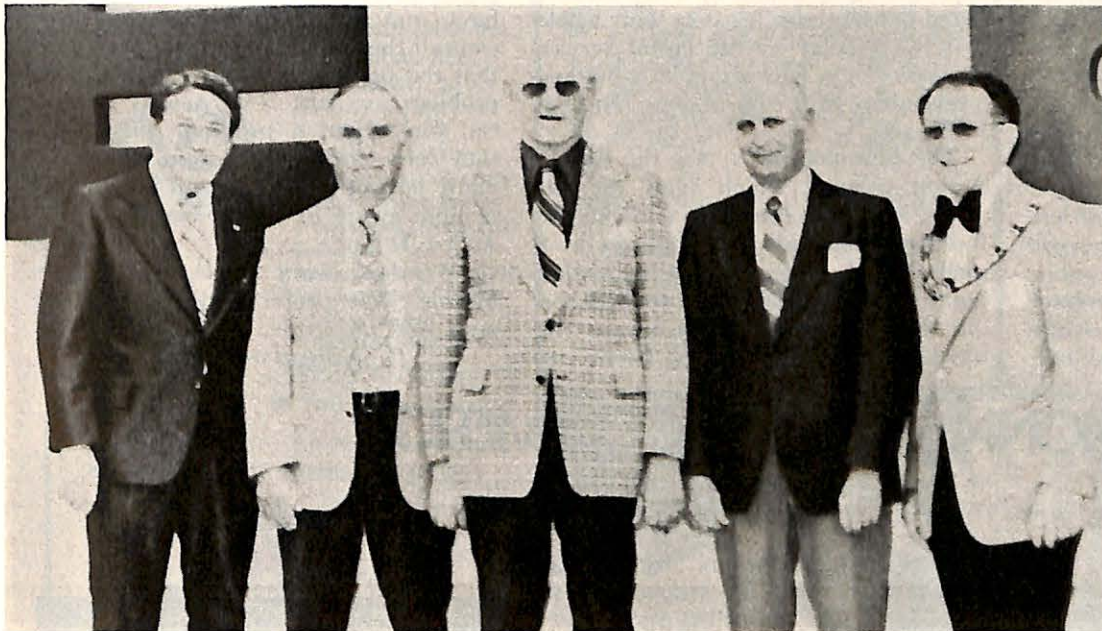

PRIOR TO the dedication of Beatrice, NE, Elks' new lodge, ER Joe Stiefvater (right) initiated his father-in-law Emil Dienstbier (center) and his in-law's brothers, Frank (second from left) and Bill (second from right). On hand to welcome the three Dienstbiers and 62 other new members to the order was PGER George Klein (left).



THE WINNER of the ritualistic contest held at Dickinson, ND, Lodge recently was the ritualistic team of Jamestown, ND, Lodge. Jamestown team mates, including (front row, from left) Frank DeBolt, Harold Bensch, Harold Wicks, Jim Tollefson, In. Gd. Chuck Axtman, and (back row) Bill Burkett, ER Robert Monson, Mel Kachel, and Est. Lead. Kt. Daryl Hanson, will represent North Dakota at the national convention in July.



A RECREATION sports banquet was held recently at Steubenville, OH, Lodge during which Coach Rich Wilinski (second from left) of the Catholic Central Crusaders received a Coach of the Year award. ER John Mulrooney (left), who presented the award, the coach's wife Barbara, and Trustee and Youth Chm. George Creegan (right) praised Mr. Wilinski for his understanding of, and inspiration to youth.

Where The Action Is

(Continued from page 36)

someone who isn't treating the public squarely learns that we'll put their name in print as not cooperating fairly, they usually back down and do what's right. It's a shame that so much pressure often has to be brought to bear on some people or companies or agencies, but at least the public has some recourse. More and more people are turning to their local Action service to get them the justice they just can't seem to get any other way."

Castine and his staff of five researchers and two secretaries accept both phone and mail requests, which now is unusual among other newspaper Action services. Most will not accept phone calls but will have an Action hot-line with a recorded message suggesting the caller write his request. In most cases, the complainant is asked to include two stamped envelopes. One self-addressed for a quick, personal reply, and another which the Action editor may forward to the appropriate person who may be able to solve the problem.

It is believed among most Action editors that their consumer-oriented columns spawned the many hot-line phone services many communities now have to help people cope with stress, drugs, and alcoholism. It was a natural out-

growth of the Action services for people to have a similar hot-line to phone for immediate help in an emotional crisis.

There appears to be a trend across the nation in which aid requests are funneled to the Action columns from outside or third party sources, in addition to direct requests from readers.

"We have attorneys refer clients and cases to us," says Dick Moody, editor of "Trouble Shooter" in the *Seattle Times*. "Often we can work together to help someone who is being taken advantage of."

Moody, three researchers, and a secretary work on an average of 7000 requests a year for the column which runs every day except Saturday. The column has been running since 1963 and Moody has been its editor for nearly nine years. Requests range from a customer complaining to a dry cleaner about getting back his shirt with a hole in it, to a delay by the Postal Service in delivering a package plainly marked 'perishable,' to a case of bats reported in the attic.

The *Boston Globe's* "Ask the Globe" Action column, which "gets the answers, solves the problems, and cuts the red tape," recently was asked by a man about how to get rid of hawks that hang out at his wife's new bird feeder. "Is there any way to discourage the hawks?" he wrote. "Ask the Globe" re-

plied: "No. The hawks are only doing what comes naturally: looking for food. Spring will take care of your problem, and the hawks' problem too, as their natural food becomes more readily available."

Catering to the public's growing desire for visual news, many television stations across the country have taken up the Action service idea from newspapers and are adding a few minutes of "show and tell" action to their newscasts.

"Consumer Watch" and "Fact Finder" segments of TV news programs are proving very popular as audience-builders.

"We try to solve a problem before we go on the air with it," says Frank Mathie of "Action 7" for the ABC-TV affiliated station in Chicago, WLS-TV.

Just as newspaper Action editors prefer to run a complaint only when they can tell the complainant and the public that the paper has already solved their problem, so do TV Action editors run film about a problem only when they have found a solution. The dramatic impact is greater and the viewer is more aware of the power of the TV Action helper.

"We don't want to be tough," says Mathie. "We prefer to be the middle men and arbitrate, encouraging dia-

(Continued on page 59)

ELKS NATIONAL SERVICE COMMISSION

"So long as there is a disabled veteran in our hospitals, the Benevolent and Protective Order of Elks will never forget him."



A veterans remembrance award was presented by SP Robert Carter to VP Don Collins and ER Stan Stockwell for the work with veterans undertaken by Waukegan, IL, Lodge. Brothers Collins and John Stouffle also received commendations for their individual work with the veterans at Downey VA Hospital.



Joseph Mackney (second from right), Jefferson Barracks Veterans Hospital director, accepted Belleville, IL, Lodge's recent financial donation to the hospital from state Vets Chm. John Moreiko, while ER K. F. Dahm (right) and M. Raymond Robinson (left), chief of voluntary service, observed. The funds were for the purchase of console color television sets for the hospital residents.



United States Administrator of Veterans Affairs Max Cleland (center) conferred with Elks National Service Commission representatives George Malekian (left) and Bryan McKeogh in Washington, DC, recently. The gentlemen were attending the annual meeting of the Veterans Administration Voluntary Service National Advisory Committee.

Sports LIQUIDATORS

8942-33 LANKERSHIM,
SUN VALLEY, CAL. 91352

SPECIAL 'GET ACQUAINTED' OFFER:

★ **25** Famous, Popular and Proven LURES \$7.95
All Different . . . for only



IT'S LIKE ORDERING 5 LURES
AND GETTING
20 LURES
FREE
OF EXTRA CHARGE!

★ The LURES in this "SET" were chosen by Expert Fishermen, as the Most widely used, PROVEN Fish-Catching Lures in use today! Ideal to replenish any Fisherman's supply for Any and All Fishing Trips! A Great "ALL AROUND" LURE SET...for Lake, River, Stream or Pond!

(Value over \$20.00).

* READY for INSTANT FISHING!

* Fantastic TELESCOPING ROD & REEL is perfect for instant Fishing! Pull . . . Rod opens to FULL 6-Ft. Spinning Rod! Yet only 14" Closed for Easy Carry!



* Perfected Medium Action!
* Tubular Glass, Specie Cork Hand Grips, Stainless-Steel Guides. Matched with SHAKESPEARE SPINNING REEL! Level-Wind, Multi-Disc Drag, Anti-Reverse, Precision Gear, 3-to-1 Gear Ratio, Holds 150-Yds. 8-Lb. Mono. High Quality! Sturdy! A Great Combination!

Telescopic ROD & REEL COMBO . . . only \$18.95
ROD only \$9.95 — REEL only \$9.95

● Fish while you eat or sleep without effort! . . .with this "MECHANICAL REEL".
★ IT WILL HOOK . . .CATCH, and REEL-IN your Fish AUTOMATICALLY! Just bait-up and SET this Automatic Fisher like a spare line tied to your Boat, Pier, or overhanging Tree Limb, go to sleep, eat or rest, "Mechanical Reel" will HOOK one and bring it in. Great for Camping. COMPLETE with Tie-Line, Trigger Release, Line and Swivel.
★ TWO (2) for only \$2.99



TWELVE "Famous" SPINNERS!

LAKE and STREAM Tested FAVORITES! A Large purchase enables us to offer this Well Known ASSORTMENT of Lures . . . (A \$7.00 Value).

★ 12 For only . . . \$2.95

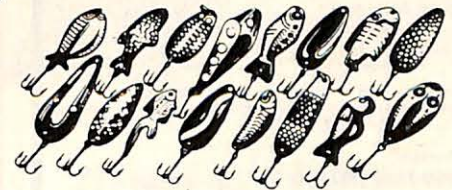

TWELVE "Famous" SPOONS!

LATEST Assortment of SHAPES, WEIGHTS, and ACTIONS! A COMPLETE SET . . . to meet every Fresh-Water Fishing need! (A \$6.00 Value).

★ 12 For only . . . \$2.79

● FLUORESCENT "FIREBALL-FLOATS".



Always Visible! Day or Night. . .even underwater. Assorted Sizes. (A \$2.50 Value).

SPECIAL . . . 10 for \$1.19

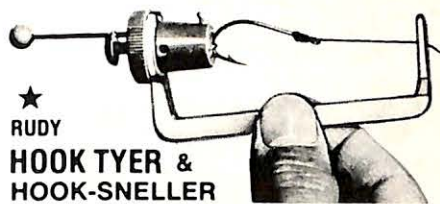

★ RUDY HOOK TYER & HOOK-SNELLER

Makes Tying ANY Hook a BREEZE! Just slip the Line in, Twist the Knob, Pull it Back . . . a Neat Uniform KNOT! Professional Knots that STAY TIED. Ties CLINCH Knots, BARREL Knots, DROP-LOOPS, End-Loops, Tapered Leaders. Also SPLICES Line! A Handy Tool for Every Fishing Need.

★ Only . . . \$1.79

● 50-Assorted SNAP-SWIVELS.



5-most used sizes for every Fishing use. The Best! Every Fisherman needs these.

● 50-SWIVELS Ass't'd. sizes . . . \$1.99

● The 3" SHORTY!



Nylon-Covered WIRE LEADERS.

Big Fish have very Sharp Teeth! "SAFE-GUARD" from losing your Lures, Plugs Spinners! 15-Lb. Test with Snap and Swivel.

● SPECIAL 15 for \$1.79

TRIPLE 'XXX' MONOFILAMENT SUPER-FINE QUALITY LINE!

SPECIAL JUMBO BULK-SPOOLS



● New FRESH-STOCK Newest GOLD color.

★ The BEST!

- XTRA SOFT! Will NOT stiffen in any weather!
- XTRA STRONG! Small diameter, Low stretch!
- XTRA INVISIBLE! Gets More Strikes!

Lb. TEST	Approx. YARDS
4-Lb.	2700
6-Lb.	2200
8-Lb.	1500
10-Lb.	1250
12-Lb.	1000
15-Lb.	750
20-Lb.	600
25-Lb.	570
30-Lb.	400
40-Lb.	350
50-Lb.	275

● SPECIAL DISCOUNT ALL LB.-TEST SAME PRICE. ONLY \$2.95 EACH.

* XTRA SPECIAL!

* BUY 2-SPOOLS For Only \$5.90 and Receive a \$2.00 LINE-WINDER FREE!

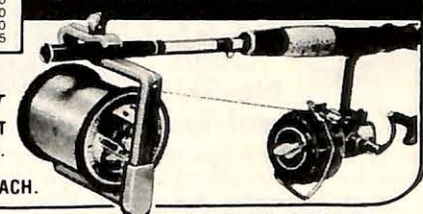

* SATISFACTION GUARANTEED . . . or Full Refund.

#0110 * SPECIAL . . . 25-Different "LURE-SET" . . . only \$7.95

- | | |
|--|---|
| #0221 <input type="checkbox"/> 12-Different SPINNERS . . . only \$2.95 | #1001 <input type="checkbox"/> Triple XXX BULK SPOOL . . . only \$2.95 LB. Test: _____ |
| #0331 <input type="checkbox"/> 12-Different SPOONS . . . only \$2.79 | #1002 <input type="checkbox"/> 2-SPOOLS & LINE-WINDER . . . only \$5.90 LB. Test: _____ |
| #3490 <input type="checkbox"/> 2-Mechanical REELS . . . only \$2.99 | #1730 <input type="checkbox"/> 50-Ass't'd SNAP-SWIVELS . . . only \$1.99 |
| #1270 <input type="checkbox"/> 10-Ass't'd FLOATS . . . only \$1.19 | #1530 <input type="checkbox"/> Telescopic ROD & REEL COMBO . . . only \$18.95 |
| #1850 <input type="checkbox"/> RUDY HOOK-TYER . . . only \$1.79 | #3020 <input type="checkbox"/> TELESCOPING ROD . . . only \$9.95 |
| #1560 <input type="checkbox"/> 15-WIRE LEADERS . . . only \$1.79 | #1360 <input type="checkbox"/> SPINNING REEL . . . only \$9.95 |

● Please Add 75¢ for Postage and handling. ● Send FREE DISCOUNT CATALOG

* MASTER CHARGE NAME _____
 * BANKAMERICARD ADDRESS _____
 Please List
 Interbank No. CITY _____ STATE _____ ZIP _____
 Acct. No. ● Please send check Cash or Money Order
 Expiration date. (Must have). (Because of the amazingly low price, we cannot accept C.O.D.'s)

Sports LIQUIDATORS

8942-33 LANKERSHIM, SUN VALLEY, CAL. 91352

L.L.Beantm

Outdoor Sporting Specialties



Chino Pants

You get real wearing pleasure from our strong and soft chino twill trousers. Two-ply double twisted yarns of polyester and combed cotton. Permanent crease. Absolutely washable with no ironing required. Neat looking for sports or work. Color: Tan. Men's even waist sizes only.

Sizes 30 to 38. Inseams 29", 31" and 33". Price, \$9.75 ppd.

Sizes 40, 42 and 44. Inseams 29" and 31". Price, \$9.75 ppd. Sizes 46, 48 and 50. Inseams 28" and 30". Price, \$11.00 ppd.

Lined Chinos. Same as above but fully lined with our famous Chamois Cloth. A thickly napped, soft and comfortably warm 100% cotton flannel.

Sizes 30 to 44. Inseams 29", 31" and 33". Price, \$19.25 ppd. Sizes 46, 48 and 50. Inseams 28", 30" and 32". Price, \$21.50 ppd.

Please Ship Postpaid

Chino Pants, @ \$ _____
size _____ inseam _____

Lined Chino Pants, @ \$ _____
size _____ inseam _____

Check Enclosed Master Charge
 BankAmericard American Exp.

Card Number _____

SEND FREE CATALOG Expiration Date _____

Name _____

Address _____

City _____

State _____ Zip _____

L.L.Bean, Inc.

7102 Cedar St., Freeport, Maine 04033

NON-METAL TAPS



SAVE HEELS
Quiet,
No-Skid,
Steel-Tough

Run-down in 3 months Like new with NO-NOISE

Amazing polyurethane taps keep heels perfect for months. Attach in seconds to any heel, and no one can tell you're wearing taps. Men or ladies size.

KICK SHOE REPAIR COSTS TODAY!

Money-back guarantee.

7 pair only \$2. 12 pr. \$3.



(Can save you \$4.00 in heels) ©1971

HALE HEEL COMPANY

44 Chip Rd., Middlefield, Mass. 01243

GREAT SEAL OF THE UNITED STATES FULL COLOR BOLT-ON AUTO EMBLEM

Proud to be an American? Display this handsome, fine quality emblem on your car.

The Great Seal of the U.S. is reproduced on brass, beautifully enamelled in full color, and bonded to stainless steel. Made to last. Bolts easily on any part of car. Available in flags of other nations.



\$6.95 plus \$1.00 postage & handling.

EMBLEMS CO. 61 Noel Drive, No. Arlington, N.J. 07032

ELKS FAMILY SHOPPER

More for your money

by Mike LeFan



SHORT MONTH, LONG BARGAINS

February is the shortest month of the year, but it's not the least bit short on bargains to help you get more for your money.

For instance, a bunch of household items are marked down. Curtains and draperies, rugs, table lamps, china, silverware, and general housewares are on sale. You wouldn't realize it by the weather, but this is a good time to shop for an air conditioner for next summer.

Audio equipment such as stereos, tape players and recorders, and radios continue at reduced prices. Toys are still on sale this month too.

Clothing bargains for February include sportswear, winter coats, hosiery, shoes, and winter clothes.

This is a big month for storewide clearance sales and winter close-outs. Also check for savings at the Lincoln's Birthday, Valentine's Day, and Washington's Birthday sales.

Supermarket Snoop's cart of bargains includes fresh oranges, grapefruit, mushrooms, Brussels sprouts, rhubarb, rutabagas, turnips, and sweet potatoes.

Get more for fresh produce money by knowing what and when to buy. Get the most vitamins, minerals, and other nutrients by proper selection, storage, and preparation of fresh fruits and

vegetables. Sweet potatoes, for example, hit their peak season between October and April. Look for those with evenly colored skins of light tan or copper, and avoid any with holes, cuts, or rot. Don't refrigerate except after cooking, because the cold causes internal discoloration and decomposition. Sweet potatoes are a good source of vitamins A and C.

Fresh mushrooms are available all year, with the seasonal peak from November to April. The best fresh mushrooms have clean, closed caps around the stems. Gills and undersides should be pink or light tan, so avoid mushrooms with brown or black gills—they're old. Caps are more tender than stems.

Food drying is an ancient art—and still a good way to preserve fruits, vegetables, and meats. The U.S. Department of Agriculture has a new booklet telling about food drying methods and supplies. For your copy of *Drying Foods at Home*, send 45c to Consumer Information Center, Dept. 117E, Pueblo, CO 81009.

I've gotten another sackful of cards and letters advising where you can buy electric teakettles, but since these latest arrivals duplicate last month's info I'll not go into details. One fellow said "For the life of me I can't under-

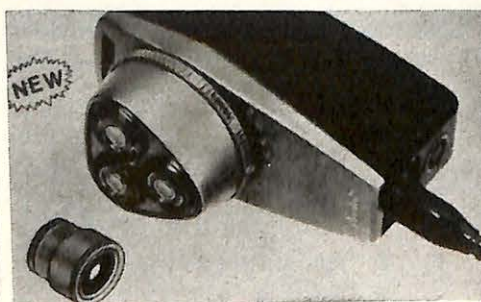

NORELCO SHAVER SHARPENER

Get added years of use from your rotary shaver. Fast, safe and easy to use—just slip over shaving head and switch on. In seconds you can sharpen your Norelco shaver . . . and keep it sharp! Makes worn heads give smoother, comfortable shaves. No more costly replacement blades to buy! Fits all rotary shavers.

\$3.99 plus 50¢ hdlg.

holiday Gifts Dept. 702-8B Wheat Ridge, Co 80036



British West Indies

Get this exciting collection of all mint, genuine postage stamps for only 10c. Tropical Flowers, Wildlife, Caribbean Dancers, and Water Sports are colorfully shown on these beautiful stamps from the West Indies. The Virgin Islands, Saint Vincent, Montserrat, Trinidad & Tobago are only a few of the exotic countries included in this special offer. FREE GIANT CATALOGUE included. Also other fine stamps from our approval service which you may purchase or return, without obligation. Jamestown Stamp Co., K28EM, Jamestown, N.Y. 14701

stand why anyone would pay that much for something with only one use when you could purchase a 'hot pot' and be able to heat more than water." However, a lady said her electric teakettle is wonderful and she "would hate to be without it." So there you have it. Thanks to the following people for comments and addresses: R. K. Powell, Albany, OR; Mrs. E. G. Andreen, Twenty-Nine Palms, CA; Mrs. R. D. Rukes, Springfield, MO; Mr. Maloney, Elks National Home, Bedford, VA; E. S. Leonard, Greenwood, NE; Alfred Dunn, Lodge 2023, Fairless Hills, PA; Mrs. M. L. Summers, Bartlesville, OK; and Mrs. Donald Otten, Mattawan, MI.

There's a new, concise paperback manual of ways to conserve energy in home heating and cooling, appliances, water use, gas mileage, and more. It contains good info for folks living in apartments. It's a usable collection of energy saving ideas, many of them do-it-yourself. *150 Ways To Save Energy And Money* is available from Pilot Books, Dept. MM, 347 Fifth Ave., New York, NY 10016, at \$2.50 per copy, postpaid.

Learn how to properly clean and preserve those costly plastic surfaces in bathrooms and kitchens. Ditto for stainless steel, baked enamel, ceramic tile, fiberglass, Formica and porcelain enamel. Order the free pamphlet *Doing It Over... And Maintaining Your Investment* from SOFT SCRUB, Dept. MM, 274 Brannan St., San Francisco, CA, 94107.

Don't pay luxury prices for cleans-ing creams and skin softeners when ordinary petroleum jelly sells for only 89c per jar and works just as well. It's an effective softener for elbows, heels, and chapped hands—just as good as products costing five times as much.

Attention fishermen: get this free mail order catalog of do-it-yourself lures, equipment repair items, and other fishing needs. Order your copy of *TACKLE CRAFTERS Discount Components Catalog* by writing Boyd Pfeif-

er's TACKLE CRAFTERS, Dept. MM, 9306 Joey Dr., Ellicott City, MD 21043.

"Dear Mike: We are having trouble and don't know what to buy or what to do to remove moss growing on our roof and to stop its growth. Will you please let me know"—Raymond G., Ogdensburg, N.Y.

Raymond, I know that chlorine solutions are helpful, but can't say what sort of mixture or which product. Can any of you readers suggest an effective anti-moss treatment for Raymond?

Last chance to order your new 1978 *Bargain Calendar*, showing this year's best buys month by month. Send \$1 and a stamped, self-addressed business-size envelope to More For Your Money, 1802 South 13, Temple, TX 76501.

Get more for your coffee money with this drip coffee tip. When making coffee for yourself make the first cup as usual, but leave the grounds in the pot or filter. When you're ready for another cup, add just a tablespoon of fresh coffee to those leftover grounds and pour through two cups of water instead of one. More for your money every time.

Send me your tip for "Money Saver of the Week" and get a fortune in fame, plus a pittance of a prize if your tip is published.

Money Saver of the Week: Congrats to Mrs. John Eckroth of Mandan, N.D., for sending in this moneysaver. When you buy bath towels, she says buy an extra one. Cut it into eight washcloths and stitch around the sides. Or use pinking shears to cut them out, and the pinking will prevent raveling. Washcloths cost a dollar apiece, so a \$3 towel will save you \$5 on washcloths. You're welcome.

Send questions and tips to Mike LeFan c/o More For Your Money, 425 W. Diversey, Chicago, IL 60614.

Because of the volume of mail received, individual replies cannot be made.



*world's thinnest,
most elegant*

*LCD timepiece
... only \$40*

LeMARQUIS

We sold out each time we advertised LeMarquis. We now have more in stock, but quantities are limited... so order today. LeMarquis incorporates all the latest developments in space-age technology. Check these features:

- World's Thinnest LCD digital watch — thinner than most conventional watches — only 6 mm thin.
- Classic Styling — the look of elegance that will last a lifetime.
- Practical — see the time all the time, displays the time, month, date, and seconds in an 'always visible' LCD digital readout.
- Solid State Microelectronics — no moving parts to wear out. One easy to buy battery lasts approximately a year.
- Night Viewing — a push of a button illuminates the display.
- Quartz Crystal Design — allows ±3 minutes per year accuracy.

AVAILABLE EXCLUSIVELY BY MAIL

Order today for immediate delivery. LeMarquis comes with a gift box at no extra charge. Available only in gold tone with imported lizard skin band at \$40. If you would prefer a beautiful gold mesh bracelet instead of a lizard band, add \$10.00.

CREDIT CARD BUYERS: TO ORDER CALL TOLL-FREE 24 HOURS A DAY

(800) 854-3831

TO ORDER IN CALIFORNIA, CALL COLLECT (714) 540-4444

DWS marketing international
17875 Sky Park North, Suite G, Irvine, California 92714

Call our toll-free number or send your personal check, money order, or credit card information to us. We accept B/A, VISA, M/C, AM, EX. Add \$1.75 for insured shipping and handling. California addresses add 6% sales tax.

30 DAY NO-RISK TRIAL — 100% SATISFACTION GUARANTEED
"If within 30 days you are not 100% delighted with your selection, you may return it to us and receive a prompt and courteous refund in full."
©DWS marketing international 1977

Winter Special!

**Baby's
First Shoes
Bronze-Plated
in Solid Metal**

only \$3.99
A PAIR UNMOUNTED



Limited time only! Baby's precious shoes gorgeously plated in SOLID METAL, only \$3.99 pr. Don't confuse this offer of genuine lifetime BRONZE-PLATING with painted imitations. Order in complete confidence with our full 25-year Warranty. Also Portrait Stands (illustrated), ashtrays, bookends, TV lamps at great savings. Ideal Gift for Dad or Grandparents. **SEND NO MONEY!** Rush name & address for full details, money-saving certificate and handy mailing sack to:

AMERICAN BRONZING CO.
6533-B25, Bexley, Ohio 43209

**NEW! Complete Home
FRUIT GRINDER
and CIDER PRESS**

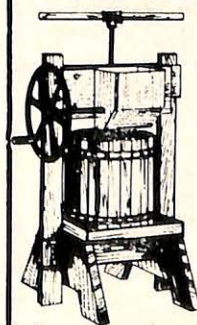

An extremely efficient double purpose unit available completely assembled or in low cost kit form. Grind your own apples (and many wine making fruits) in the top mounted grinder—then press the pulp to produce delicious cider and fruit juices. Enjoy fresh pure cider, and vinegar for year round cooking,

from bruised or fallen apples. Full bushel capacity—over 4 ft. tall! Constructed from spruce and Vermont maple hardwood to last a lifetime. Plans and kits also available. Send for free catalog.

GARDEN WAY RESEARCH
Dept. 80122P, Charlotte, Vermont 05445

SPACE-AGE HEET SHEET KEEPS YOU WARM WITHOUT ELECTRICITY

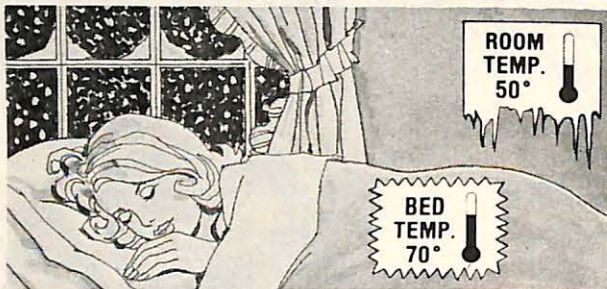

- NO WIRES!
- NO OPERATING COSTS!

only \$8.98 (Twin-Size)

YOUR OWN REFLECTED BODY HEAT KEEPS YOU COZY!

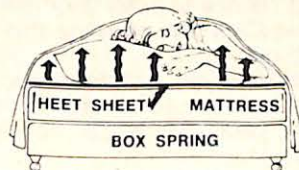

A space-age "miracle!" Made of Thermalfab . . . the super-effective insulating material developed to protect astronauts in the incredible cold of outer space!

You sleep on it — not under it. Just place the incredible HEET SHEET between your mattress and bottom sheet. INSTANTLY, it retains and reflects your own body heat right back to you . . . keeps you cozy and warm as an electric blanket without a single watt of electricity! And you stay warm all night with your thermostat turned down; you can save plenty on heating bills. Lets you use lighter-weight blankets too — so you awake relaxed and refreshed. SPACE-AGE HEET SHEET is 100% safe, lightweight and

portable. Never gets dirty . . . the special heat-reflecting fabric is stain resistant too, so it even doubles as a mattress pad.

Order one for every bed in your house (special savings on extras). If not delighted, return within 14 days for refund (except postage & handling). MAIL COUPON TODAY!

© 1977 American Consumer Inc., Caroline Rd., Phila., PA 19176

MAIL NO-RISK

AMERICAN CONSUMER, Dept. HSH-34
Caroline Road, Philadelphia, PA 19176

Yes! Please send me the SPACE AGE HEET SHEET(S) ordered below:

- (#009) TWIN-SIZE only \$8.98 each (2 for \$16.98)
- (#017) DOUBLE-SIZE only \$9.98 each (2 for \$18.98)
- (#025) KING-SIZE only \$11.98 each (2 for \$22.98)

Please add \$1 postage & handling for one Sheet. \$1.50 for two, \$3 for four.

If after receiving my order I'm not delighted, I may return it within 14 days for refund (except postage & handling).

8558

Amount enclosed \$_____ PA residents add 6% sales tax. Check or money order, no CODs please.

CHARGE IT: (check one) Exp. Date _____

BankAmericard/Visa American Express

Master Charge Bank Number _____

Credit Card # _____

Name _____

Address _____ Apt. # _____

City _____ State _____ Zip _____

Canadian Customers please send orders to: Mail Store Ltd.

Dept. HSH, 312 Rexdale Blvd. Toronto, Ontario M9W1R6

(Ontario & Quebec residents add sales tax)

Elks Family Shopper



A BOOT TO SUIT THE LADIES. Handsome Ladies' Cavalier Boot is genuine glove leather with adjustable buckle strap, smooth no-seam vamp. Has platform sole, 2" covered heel. In Camel, Black, Brown, Bone, Full and half sizes: 6-10½, AA, AAA; 5-10 A, B, C. \$24 plus \$1.50 shpg. Vicki Wayne-E2C, 600 S. Country Club, Tucson, AZ. 85716.



PERSONALIZED PLACE SETTINGS celebrate birthday, wedding, anniversary, holiday. Hand-crafted ceramic. Choose Teddy-Bear, Hobby Horse, Train, Buggy, Schoolhouse, Church, Gingerbread Boy, any name(s). 10" plate, mug, and bowl \$24.95; 10" plate and mug, \$19.95. Ppd. Emme's Emporium, E2, 849 Cramer Court, Hinsdale, IL 60521. Free color brochure.

NOW! BADGE-A-MINIT™. BREAKS THE PRICE BARRIER... MAKE BUTTONS LIKE THESE FOR EVERY COMMUNITY USE

While the cost of everything else is skyrocketing, BADGE-A-MINIT, Ltd. announces another breakthrough in badge-making technology. Now you can make the same high quality, colorful, plastic-protected, metal pin-back badges and buttons instantly for fairs, reunions, local events, school and club activities, elections, for business promotions or just for Fun for LESS than ever before! Discover "Badge Power": power to persuade, promote or create sympathy with your cause; let the guests at your next party "let it all hang out" with buttons that they make and wear upon arrival. Make one or one hundred — whenever the occasion calls for strong motivation. The button business can be a great side line for an enterprising son or daughter, too!



COMPLETE SYSTEM

\$19.95

GET FREE SAMPLE BUTTON AND FULLY ILLUSTRATED DETAILS

The BADGE-A-MINIT system includes steel and fiberglass reinforced Lexan plastic hand die press, high impact color coded die set, 12 badge shells, 12 pin-back parts, 12 pastel perforated message discs, 12 plastic protective circular discs and colorful literature on all BADGE-A-MINIT, Ltd. accessories plus fully illustrated operating instructions.

BADGE-A-MINIT, Ltd., Dept. EL-28, Box 618, Civic Industrial Park, La Salle, Illinois 61301

Yes, send me a free sample button and fully illustrated details.

I'm convinced. Rush me the complete system. I've enclosed \$19.95 (check or money order) plus \$1.75 for postage and 5% sales tax for Illinois residents. Or use my credit card indicated below.

VISA (Bank Americard) Master Charge

Diners Club American Express Carte Blanche

Credit Card # _____ Exp Date _____

Inter Bank # _____

NAME _____

ADDRESS _____

CITY _____ STATE _____ ZIP _____

SIGNATURE _____

UNCONDITIONAL MONEY BACK GUARANTEE



1000 RETURN ADDRESS LABELS \$1.00

1000 gummed economy name and address labels printed in black with ANY name, address, zip code. Up to 4 lines. Order S717 Set of 1000 Economy Labels (boxed) . . \$1.00



250 Self-Stick GOLD FOIL LABELS \$1.98

Gleaming gold foil labels stick to any clean, dry surface — need no moistening. Rich black printing, classic border. Order P6128 Set of 250 Gold Foil Labels (boxed) . \$1.98



250 Self-Stick WHITE GLOSS LABELS \$1.98

Glossy white self-stick labels cling to any smooth surface — no moistening. Sharp black printing up to 4 lines. Order P6030 Set of 250 White Gloss Labels (boxed) \$1.98

Walter Drake 3292 Drake Bldg. Colorado Springs, CO 80940

NAME _____

ADDRESS _____

CITY & STATE _____ ZIP _____

— S717 1000 Labels @ \$1 each \$ _____

— P6128 Gold Foil Labels @ \$1.98 each \$ _____

— P6030 White Gloss Labels @ \$1.98 ea \$ _____

Add 20¢ per set for postage & handling \$ _____

SATISFACTION GUARANTEED Total \$ _____

YOUR QUICK WAY TO EASY MONEY!



VINYL REPAIR

MAKE \$20 TO \$30 FOR AN HOUR'S JOB LIKE THIS

**GIVE "on-the-spot" SAME DAY SERVICE
GET "on-the-spot" SAME DAY PAY!!!**



You can be in business IN A FEW DAYS!

Sensational! That's the **MONEYMAKING POWER** of VIP Professional Vinyl Repair . . . the business of your own that can be part or full time for **QUICK AND GROWING PROFITS!** You need no study — no training — just a few hours' practice and you're ready to do repairs for pay, — **BIG PAY!** You can be in business practically overnight.

Start for less than you make in 1 hour on first job!

With just a small down payment, you get the complete VIP going-into-business kit . . . all equipment, materials, complete step-by-step instructions, business-building helps . . . everything you need!

"Wherever I see vinyl, I can do business"
"I've made as much as \$60 in 3 hours."
C. Herrera, Jr., Ariz.



9 HOLIDAY INNS FOR HUSBAND/WIFE TEAM

"These Inns have put us on a monthly allotment. We are busy every day. Wonderful to be one's own boss. We are putting on one repairman to handle business other than Holiday Inns. With our setup, we have weekly checks coming from just the Inns."
Mr. & Mrs. Bechtel, Ohio

STEADY WORK FOR 20 CAR DEALERS

"20 car dealers give me all their repair work. I call on two or three every day, take care of what's needed. No matter what the repair is, it's easy to do with VIP."
R. Lanning, Ky.



\$440 IN 9 HOURS!
"I repaired 55 chairs at the NCO Club at \$8 each — \$440 for 9 hours' work. Materials and transportation cost only \$35!"
D. Gagnon, S.C.

\$513⁰⁰ in first 10 days!
"The first 10 days I made \$513. Now getting business from 15 car dealers, 6 furniture stores, 4 restaurants and bars, and clothing stores."
H. Whaley, Wash.



HERE'S THE VIP VINYL REPAIR KIT that puts you in your own HIGH-PROFIT BUSINESS

They all started by mailing a coupon like this. YOU CAN TOO!

ALL FACTS FREE BY MAIL — NO SALESMAN WILL CALL. MAIL COUPON NOW

UNLIMITED CUSTOMERS FOR YOUR SERVICE

Auto dealers, car shops, restaurants, motels, bars, clubs, hospitals, bus companies . . . these are just a few of the places that need vinyl repairs, repeatedly. The business is there, waiting for you. And a repair job that takes 1/2 an hour to an hour can mean a quick \$15 to \$30 for you . . . most of it **PURE PROFIT!**

MEN, WOMEN, HUSBAND/WIFE TEAMS FIND VIP QUICK, CLEAN, EASY, PROFITABLE!

Both women and men enjoy this easy, profitable way to make good money fast and steady. The VIP exclusive process is so easy, the directions so simple, that anyone who can read plain English can do it. And what a money-maker! A sure way to have an independent income, or build to a business as big as you want to make it. There's no end to the demand!

GET ALL INFORMATION FREE BY MAIL. NO SALESMAN WILL EVER CALL.

Just mail the coupon. We'll rush all facts to you **FREE BY MAIL.** No obligation. No salesman will call. It's hot! Do it now!

VIP VINYL INDUSTRIAL PRODUCTS
2021 Montrose Ave., Dept. 152A
Chicago, Ill. 60618

Vinyl Industrial Products, Dept. 152A
2021 Montrose, Chicago, Ill. 60618

PLEASE RUSH BY MAIL **FREE FACTS** about VIP Vinyl Repair and how I can start making money within a few days! No salesman is to call. I am under no obligation.

Print Name _____
Print Address _____
Print City/State/Zip _____

Sun Shield

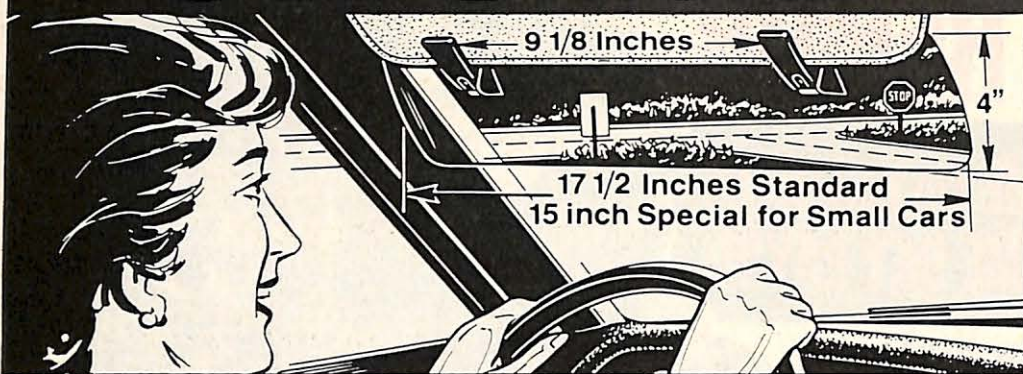

DOUBLES your driving COMFORT

- Reduces ALL GLARE and HEAT, front or side, Day or Night
- Accepted by leading safety authorities • Positive screw clamps hold securely
- Universally adjustable for look-through or shade-and-look-under.
- SATISFACTION GUARANTEED (Return within five days for full refund)

THE IDEAL GIFT • MOST ENJOYED • MOST APPRECIATED

Sun Shields, Inc. • 9179 General Court • Plymouth, MI 48170

Check or money order enclosed; Michigan residents ONLY add 4% tax.

- \$5.00 for one Sun Shield, shipped postpaid promptly.
- \$9.00 for 2 Sun Shields - Make your passenger comfortable, too!
- \$42.00 Doz. (minimum, one order) for group buyers - fleet owners.



Specify 15 in. LENGTH (not car model) for sub compact & small foreign cars.

Name _____ Street _____

City _____ State _____ Zip _____

Elks Family Shopper

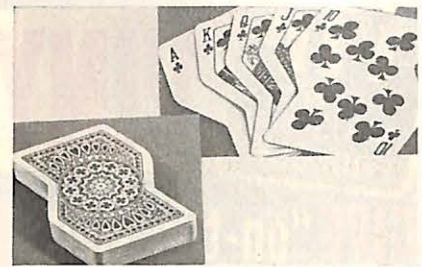

DEAL A "CROOKED" DECK for your next card game and be the life of the party. It's not a dishonest deck but actually crooked in shape. Regulation deck shuffles perfectly, fits the hand well. Order several for friends. One deck, \$1.75 ppd.; two decks, \$3.00; 6 decks, \$7.50. (Ill. res. add 5%.) Chorley House, Dept. EM3, P.O. Box 117, Wilmette, Ill. 60091.



"AMERICA BY CAR" is a big book that helps you explore America. Tells all the four-star sights to see in the U.S. including Alaska, Hawaii, plus Canada and Mexico. Tells road by road where to go, what to see and where to eat and stay. 170,000 words but costs only \$3.95 plus 35¢ shpg. Harian Publ., Dept. EL1, 18 Verbena St., Floral Park, N.Y. 11001.

DO-IT-YOURSELF

FINE GRANDFATHER CLOCK KITS

STARTING UNDER

\$200

(including West German movement)

- Heirloom quality
- Solid 3/4" hardwoods: black walnut, cherry, mahogany, oak
- Easy to assemble, parts pre-cut
- Solid brass West German chiming movements
- Money back guarantee
- Factory direct prices
- Prompt shipment

MASTER CHARGE and BANKAMERICARD/VISA ACCEPTED

Write for FREE color catalog

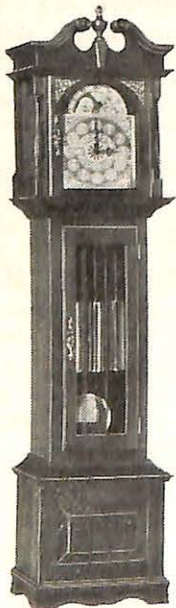

EMPEROR CLOCK COMPANY

WORLD'S LARGEST MANUFACTURER OF GRANDFATHER CLOCKS

Dept. 404, Emperor Industrial Park
Fairhope, Alabama 36532

Killer Putter!

Revolutionary New SIGHT-ALIGNMENT PUTTER: Makes Any Putt (Under 9 feet) A One-Putt Cinch! It's 100% guaranteed or your Money Back. Pick up easy bets as you sink Putt after Putt with deadly accuracy.

The First Mechanical Design Patent On A Putter in 37 Years, It's Special Cross-Hair Sight Alignment was researched and designed by touring PGA pro Brian Shillington. Correct Placement of your hands, head and feet becomes automatic. You read the greens, this exquisitely balanced Killer Putter does the rest.



Play With It For 2 Weeks and Improve Your Putting Considerably. If not satisfied, Return it for Immediate Refund, no questions asked. \$24.95 ea. (plus \$2 shipping) Specify Men's or Ladies' putter. (Left Handed Model Also Avail.)

TO ORDER, CALL TOLL FREE 1-800-528-6050, ext. 1050. (Ariz. Residents Call Collect: 602-955-9710).

Or Send Check, Money Order, or Credit Card No. (BankAmericard/Visa, MasterCard include interbank #, American Express, Diners Club, Carte Blanche) and exp. date, plus your name and address to: Starshine Group, Dept. S-211, 924 Anacapa St., Santa Barbara, Calif. 93101. Delivery will be made promptly.

SUPER STRIPPER

Powers Paint Off

FAST! CLEAN! EASY!

- Furniture • Wrought Iron, Masonry • Autos and Boats
- Hundreds more big and little jobs



PRICE BREAK! NOW ONLY \$9.95
300,000 SOLD AT \$12.95 to \$14.95

FOR 1/4" DRILLS

Works on a new principle (30 flexible carbon alloy steel fingers produce up to 75,000 stripping strokes a minute) to do the job cheaper, safer and last a lifetime. Made of solid steel. High-speed "whipping action" makes paint, rust, scale vanish as if by magic! Never buy expensive, dangerous paint removers again! SAFE TO FINE FURNITURE when used as directed. Leaves a satin smooth finish, ready for paint or stain. No sanding needed (won't raise wood grain as liquids do). Full instructions.

BOATS, HOUSE SIDING, does all big jobs in a fraction of the time.

STOPS RUST DEAD, strips rusted spots down to the bare metal fast! Cleans masonry and swimming pools effortlessly.

Soft Goggles.

\$5 Value. Only \$2.95. Use with any power tool. High-impact plastic. Adjustable headband fits all.

SUPER STRIPPER (Dept. ADC-8)
Box 489, West Haven, CT. 06516

Please rush..... SUPER STRIPPER(S) @ \$9.95 ea., plus \$1.00 handling. SAVE \$2. Order TWO for \$19.95. We pay postage. Order: COARSE for big jobs FINE for furniture

Also rush SOFT GOGGLES @ \$2.95 ea. ppd. Enclosed is \$ (Please add applicable sales tax.)

CHARGE: Master Charge BankAmericard/Visa

Acc't. # _____ Sorry, no CODs

Interbank # _____ Exp. Date _____

PRINT NAME _____

ADDRESS _____

CITY _____ STATE _____ ZIP _____

Dealers' Inquiries Invited.

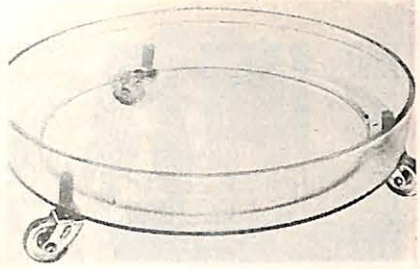

ROLLING PLANT STAND lets you move heavy houseplants with ease to rotate them for proper light and growth. Clear acrylic stand is 12 1/4" in dia. with 2" high rim to prevent spills. Rolls easily on 3 sturdy casters which protect furniture, floors, rugs. \$6.98 plus 50¢ shpg. Colonial Garden Kitchens, Dept. ELX, 270 W. Merrick Rd., Valley Stream, N.Y. 11582.

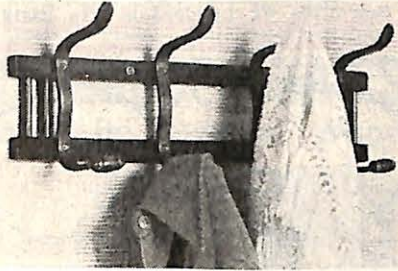

YOU'LL FIND SO MANY USES for this Bentwood Rack—in the hall for coats, hats, umbrellas; in child's room for robe, hat, toys; in the kitchen and bathroom. Real wood rack with four double hooks is finished in pecan tone. 19 1/4" long, 7" tall; protrudes 4" from wall. \$4.99 plus \$1.00 shpg. Holiday Gifts, Inc., Dept. 702-8C, Wheat Ridge, Colo. 80036.

100% GENUINE NATURAL DIAMONDS

1/4 to 4 CARAT FROM ONLY **\$9.95!**

These beautiful diamonds are the real thing. Not artificial or synthetic. Each diamond comes with a signed and notarized legal certificate guaranteeing that it is a 100% GENUINE NATURAL DIAMOND.

The average diamond in an engagement ring is 1/2 carat and normally sells in jewelry stores for \$500 to \$1,000. A 4 carat diamond normally sells for \$10,000 to \$20,000. **HERE ARE OUR FANTASTICALLY LOW PRICES:** 1/4 carat only \$9.95! 1/2 carat only \$17.95! 1 carat only \$29.95! 2 carat only \$49.95! 4 carat only \$79.95!

HOW CAN WE DO IT? We make huge diamond purchases. Then, rather than cutting and polishing these diamonds, we leave them in their pure natural form—unprocessed. These are 100% PURE diamond nuggets cut to beautiful shapes by Mother Nature alone. We purchase perhaps 20,000 times as many unprocessed diamonds as an average jeweler, who rarely carries them in stock. So do not be surprised when your jeweler says that he can special order an unprocessed diamond of comparable appearance but costing 20, 30, or 40 times our prices!! We are confident that you will definitely not pay less for diamonds of equivalent quality and appearance!

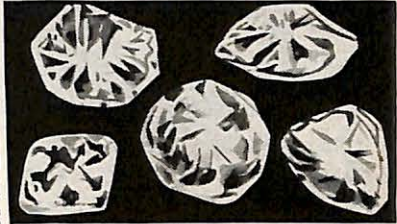

Our dazzling 100% GENUINE DIAMONDS make the perfect gift and investment. Our prices are unbeatable. Treat a loved one—treat yourself!

Our wild unprocessed diamonds are impressive and extremely stylish. We pay extra for our diamonds because they are carefully and individually hand-selected for quality and stylish appeal. Only the MOST SPECTACULAR DIAMONDS are accepted. They go beautifully on pendants, necklaces, earrings, tie-clasps, cuff links, bracelets, rings, etc. Your jeweler can easily mount these diamonds into whatever setting you desire. They are EXQUISITE JEWELS for yourself, ELEGANT and ORIGINAL GIFTS for loved ones, GREAT CONVERSATION PIECES, and SUPERB INVESTMENTS. Dazzling on both women and men.

A diamond is the most PRECIOUS, the HARDEST, and said to be the LUCKIEST of all gems. It is the most accepted symbol of love in the world. It is a perfect way to show a loved one how much you care.

A diamond is forever, but this offer is not! With the threatening civil war in southern Africa and the exhaustion of most world diamond mine reserves, diamond prices are skyrocketing, and unprocessed diamond prices are soaring the fastest. Our limited stock of the rare 4 carat diamond is a phenomenal buy. The bigger the diamond, the more spectacular its appearance and the greater its investment value. This is truly the BEST INVESTMENT BUY ANYWHERE! We will not be undersold!! If you want these diamonds at these rock-bottom low prices, send immediately. 15-DAY UNCONDITIONAL MONEY BACK GUARANTY OF COMPLETE SATISFACTION. YOU TAKE NO RISK AT ALL!

MAIL THIS NO-RISK COUPON TODAY!

U.S. DIAMOND IMPORTS
Dedicated to serving satisfied customers

3600 Wilshire Blvd., Suite 1510, Dept. A15 Los Angeles, CA 90010. 15-DAY FULL MONEY BACK GUARANTY. Each diamond comes with a luxurious velvet diamond pouch and a legal certificate of authenticity.

DIAMOND SIZE	QUANTITY	TOTAL
1/4 carat at only \$9.95 each!		\$
1/2 carat at only \$17.95 each!		\$
1 carat at only \$29.95 each!		\$
2 carat at only \$49.95 each!		\$
4 carat at only \$79.95 each!		\$

Order 3-5 diamonds, deduct 10% on total purchase price. Order 6 or more, deduct 20%!

ADD POSTAGE & HNDLNG \$1.05

TOTAL \$

Name _____
(Print)
Address _____
City, State, Zip _____

©1977 by U.S. Diamond Imports

So easy to handle you guide it with **Just ONE HAND!**



No Footprints!
No Wheelmarks!
No Struggle!

Tiller users, for heaven's sake, please don't buy nor put up any longer with any other make of Tiller without giving yourself a chance to find out about our wonderfully different and better kind of Tillers — with **POWER DRIVEN WHEELS** and with tines in the **REAR** instead of the **FRONT!** Please let us send you complete details, prices, **OFF-SEASON SAVINGS**, etc. Mail coupon below now to: **TROY-BILT® Roto Tillers**, 102nd St. & 9th Ave., Troy, N.Y. 12180

TROY-BILT® Roto Tillers, Dept. 80552
102nd St. & 9th Ave., Troy, N.Y. 12180

Please send the whole wonderful story of **TROY-BILT® Roto Tillers** including prices and **OFF-SEASON SAVINGS** now in effect for a limited time. (Please Print Clearly)

Mr. _____
Mrs. _____
Ms. _____
Address _____
City _____
State _____ Zip _____

Stainless Steel Railroader's Lantern

You can depend on it with your life. Trainmen have for over 65 years!



Superbly Engineered! Not A Pretender!
Crafted in Fine Stainless Steel: Heavy Chrome-Plated Reflectors, Thick Black Rubber Handle To Give It Flair and Authenticity!

MAKES A LOVELY DECORATOR ACCESSORY TOO, FOR LIVING ROOM, PATIO.

This is the lantern that guided the mighty 20th Century Limited through a snowy upstate yard to switch engines . . . that swung a wide arc in the twilight to move a hundred-car freight onto the main line . . . that signalled the approaching danger of a broken track on a thick, foggy night . . . that's still in service on railroads across the country . . . the legendary Conger Lantern.

Since 1910, the Conger Company has been manufacturing these incredibly rugged fine lanterns as if men's lives depended on them—and they have. Up until recently they were available only to railroads and industry . . . but now you can own this distinctive portable, dependable lantern.

Two light sources make the Conger the perfect lantern for homeowners, campers, sportsmen and such. A general purpose down light is handy for walking and hiking and there's also a concentrated beam flashlight for distant spot illumination, highway emergencies.

Each lantern is built with the same craftsmanship and attention to detail that have made Conger the railroader's choice for over 65 years. The Conger Railroader's Lantern will last through years and years of use and abuse. Takes a standard 6-volt lantern battery (not incl.) 1-year manufacturer's guarantee. \$27.95 a pair, \$14.95 for one.



SATISFACTION GUARANTEED!

COUNTRY HOUSE, Dept. 418
P.O. Box 44, Southport, CT. 06490

Please rush me one legendary **CONGER RAILROADER'S LANTERN** at \$14.95 plus \$1.50 shipping and handling on money back guarantee.

SAVE: Order a pair for only \$27.95 plus \$2.00 shipping and handling.

Enclosed is \$..... (CT residents CHARGE IT: add sales tax.)

BankAmericard/Visa Master Charge

Exp. Date Interbank #.....

Acc't #.....

Signature

PRINT NAME

ADDRESS

CITY

STATE ZIP

1334 Bronson Rd., Fairfield, CT 06430

EASY-LIFT



LIKE A HELPING HAND.

Many people—senior citizens, arthritics, and those suffering from Multiple Sclerosis, Muscular Dystrophy or Parkinson's disease—need help getting in and out of a chair. The EASY-LIFT power cushion recliner gently lifts you forward as well as up to a semi-standing position. The lifting angle adjusts to fit your needs, controls are easy to reach, and it runs on household current. EASY-LIFT—like a helping hand.

WRITE FOR FREE BROCHURE
AND NAME OF DEALER NEAREST YOU.
AMERICAN STAIR-GLIDE CORP.
4001 East 138th Street, Dept. EE-28
Grandview, Missouri 64030

If you can use a screwdriver
and drill... you can

BUILD YOUR OWN HEIRLOOM GRANDFATHER CLOCK



at 50% or less
of retail price

- Solid ¾" kiln dried wood
- Fully Assembled/precision-made West German Movements

WRITE NOW FOR
FREE Color
Brochure of
complete line of
Grandmother,
Grandfather and
other clocks.

HENTSCH
clock company

Department 8ELF
16 Atlantic Avenue
So. Dennis,
Mass. 02660

Captain's WEATHER GLASS

An authentic handblown replica of weather forecasters used aboard Clipper Ships during the age of sail when the Captain kept a watchful eye on the "falling" glass. This decorative conversation piece actually predicts weather changes 8 to 12 hours in advance. Like the Captain, you'll consult it every day. Black metal mounting bracket and exact directions included. 11¾" high. An ideal gift. Satisfaction guaranteed. Catalog 25¢.

\$8.95 plus \$1.00 postage & handling.

Huntleigh Galleries Dept. E28
3612 Huntleigh Dr. Raleigh, N. C. 27604



FACTORY TO YOU SAVINGS!

Unique, Hard To Find LAWN/GARDEN TRACTOR ACCESSORIES



Farnam's Mini-Harrow.
Unique tool used for
thatching lawns.



MIDDLE
BUSTER



SPIKE
AERATOR

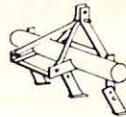

LAWNOVATOR



CULTIVATOR

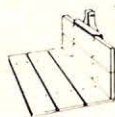

CARRY ALL

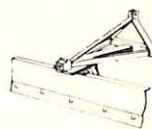

EARTH BLADE

Farnam Equipment now offers unique and hard to find accessories that fit your Lawn/Garden Tractor. Built rugged to handle the toughest chores. Plus you can save money on our factory direct prices. We feature aerators — gang reels — plows — carts — rollers — and even cranes. Start using tractor power instead of man power with these accessories. For complete prices and information on our 30 day free trial plan send coupon below.

FARNAM EQUIPMENT CO., Dept. AA-358
P.O. Box 12088, Omaha, Nebraska 68112

Please send brochure and prices on the
Farnam Lawn/Garden Tractor accessories.
No salesman will call.

Name _____
Address _____
City _____ State _____
Phone _____ Zip _____

Elks Family Shopper



BRIDGE TABLE COVERS in gold and silver make elegant cloths for bridge playing or eating. Metallic material is resistant to practically all liquids including acids, caustics, alcohols and solvents. In crushed gold, crushed silver or shiny silver. Cover, \$20.00; apron to match, \$18.00 Ppd. Stahed Co., Inc., P.O. Box 15785, Ft. Lauderdale, Fla. 33318.

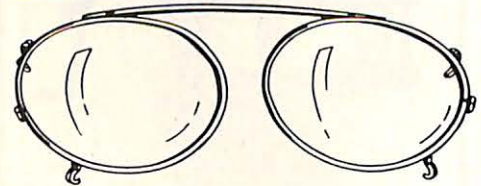

CLIP-ON MAGNIFIERS

Clip MAGNIFIERS on regular glasses. **SEE CLEARER INSTANTLY!** Read fine print of phone book and TV guides. *30-day money-back guarantee.* State age and sex. Send only \$8.95 + 75¢ handling. Precision Optical, Dept. 41-D, Rochelle, ILL. 61068

COLLAR EXTENDER

Eases Tight Shirt Collar Discomfort

10 for \$1.75

plus 25¢ postage
2 Sets of 10 for \$3.25 ppd.



Collar fit tightly due to shrinkage, washing, starching, growth, weight increase? Add up to ½ size for just-right fit instantly. Slips on and off in seconds. Ideal for men and growing boys. Send check or M.O.; no C.O.D.'s 21-day money-back guarantee.

BARCLAY, Dept. 51-B

1575 No. Dixie Hwy., Pompano Beach, Fla. 33060

16 VALUABLE U.S. AIRMAIL STAMPS, 10¢



For 10¢ we'll send you 16 U.S. Airmail stamps, worth over \$1, including 10¢ Moon Landing and 26¢ Mount Rushmore issues, to get your name for our mailing list. Plus, wonderful price lists of U.S. & foreign coins. **ADULTS ONLY.** Limit 1 to a customer. **LITTLETON STAMP Co., Dept. HA-3, Littleton, New Hampshire 03561.**

10 foreign coins, 10¢

We'll send you, for 10¢, seldom seen coins from Iceland, Israel, Pakistan, Algeria, etc. Just to get your name for our mailing list. You'll also receive wonderful price lists of U.S. and foreign coins and paper money. Offer to **ADULTS ONLY.** Send 10¢ to:

Littleton Coin Co., Dept. BM-37
Littleton, New Hampshire 03561

Triangle & Diamond- Shaped Stamps -Only 10¢



Scarce Nicaragua airpost triangle picturing wild Tapir, Spectacular Olympic sports issues. Hard-to-get stamps from Upper Volta, Monaco, Congo, etc. Big lists included. Offer to **ADULTS ONLY.** Send only 10¢ to: **GOLIATH CO., DEPT T-37, Bethlehem, N.H. 03574.**

Elks Family Shopper



WIG STRICTLY FOR MEN. It's cool, lightweight, like human hair, and stretches to fit any head, covers all hair, sideburns too. Black, off black, chestnut, dark or medium or light brown, dark blond, black or brown mixed with gray. \$8.95 ppd. Specify color, style #M-141. Franklin Fashions, Dept. EL-8, 103 E. Hawthorne Ave., Valley Stream, N.Y. 11580.

FIX LOOSE CHAIRS

Chair-Loc "Swells" Wood

Sure-acting liquid synthetic penetrates wood fibres, makes them S-W-E-L-L. Fixes loose chairs, locks rungs, legs forever tight. Also use Chair-Loc for dowels, tool and broom handles, mortised joints. Plastic squeeze bottle with applicator nozzle makes it quick, clean, easy. Over 2 million sold. Satisfaction guaranteed. 3 oz. bottle \$2.00 Ppd. N. J. residents add 10c tax.



CHAIR-LOC, Dept. E-278, P.O. Box 45 Lakehurst, N.J. 08733

CUSTOM MADE EMBLEMS

Organizations, Schools, Churches, Commercial Fund Raising and etc. Free Brochure Dept. CM 10E



F12 EMBLEMATIC JEWELRY E15
75c ea. ELKS, K of C., MASONS, ETC. 75c ea.
Free brochure Dept. EJ 12E
Fraternal Wholesale Jewelry Mfg. Co.
P.O. Box 8123, Cranston, R.I. 02920
(401) 942-4591

Amazing Mini-Vac

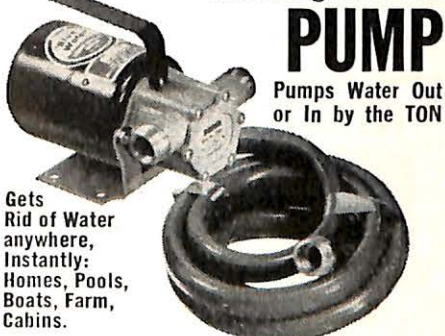

PUMP

Pumps Water Out or In by the TON

Gets Rid of Water anywhere, Instantly: Homes, Pools, Boats, Farm, Cabins.

Pumps up to 350 gallons (1 1/2 tons) per hour . . . lifts water 20 feet . . . pushes water 50 feet high. Just plug into any electrical outlet and it's ready to use. It will drain or empty flooded basements, boats, pools, sumps, tanks, silt pits etc. Or in reverse it will water gardens, fill pools, fill a boat's water supply, etc. Everything complete in one kit. Built to commercial professional standards. Instant self-priming pump. Stainless steel wear plates, glass fiber reinforced case, rock rubber impeller. System includes air cooled motor, six-foot heavy-duty ground cord, two suction and discharge hoses, brass strainer, etc. Ten year replacement plan guarantee. \$49.95 \$4.00 pp. and Hdg.

Send check or M.O. or Charge American Express or BankAmericard (Give Acct. No. and Exp. Date) 15 day Money Back guarantee

J. W. HOLST, INC. Dept. EK-28, 1864 E. US-23 East Tawas, Mich. 48730



EVERYBODY'S STEAMCLEANER!

HOT DOUBLE OFFER!

... and almost everyone is a prospect

TAKE THE FOOLISHNESS OUT OF STEAMCLEANING

- Air Conditioning
- Animal Farms
- Boats, Marinas
- Building Cleaning
- Business Machines
- Cafes, Hotels
- Cycle Shops
- Dairies
- Farms, Ranches
- Fish Markets
- Fur Farms
- Garages
- Ice Plants
- Industrial Plants
- Lawn Mower
- Meat Markets
- Print Shops
- Refrigeration
- Saw Mills
- Service Stations
- Super Markets
- Truckers
- Veterinarians

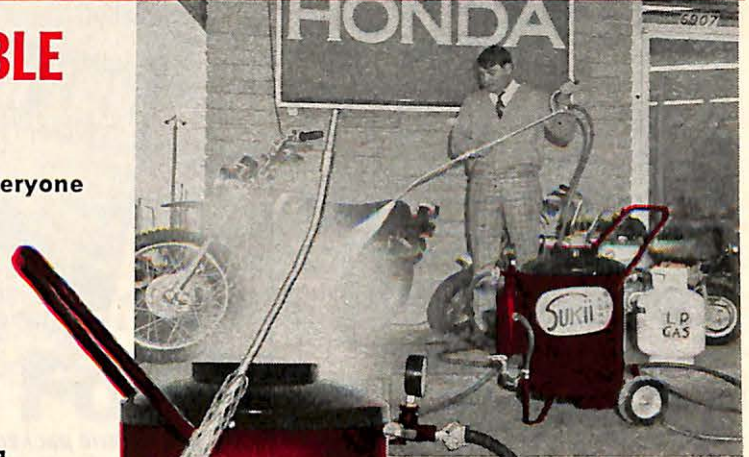

SUKII . . . lightweight, quickfiring, long-lived, easy to operate, the choice of steam cleaners. L.P. gas fired and at a price users can live with.

DESIGNED FOR SIMPLICITY. LOW MAINTENANCE COST—NO SMOKE OR FUMES.

BIG MONEY 2 WAYS



Produces Hot Steam **FAST!**

1. DEVELOP YOUR OWN SUKII DEALERSHIP—Big Money Filling Demand All Over Your Territory

Earn a giant \$200.00 profit per sale. Dozens of different kinds of businesses . . . service stations, garages, factories, farmers, etc. . . earn extra profits by saving time and work cleaning their property and equipment. Keeps customers happy, too.

2. BE A SUKII FRANCHISE DISTRIBUTOR—Earn Biggest Profits, Realize Your Dreams

Openings available right now for top-flight men and organizations qualified to step into the booming SUKII picture. Unique moneymaking program with protected territory.



Use your

- BankAmericard
- Master Charge

Send your name, account no., expiration date and identification no., if any.

MAKE YOUR SUKII PROFIT CHOICE AND MAIL COUPON TODAY!

SUKII INTERNATIONAL PH. 602-994-3270 P.O. BOX 1653 SCOTTSDALE, ARIZONA 85252

\$259⁵⁰ SHIPPED F.O.B. FROM FACTORY NEAR SIOUX CITY, IOWA

CLEAN UP RIGHT HERE Get All The Facts!

SUKII Ph. 602-994-3270 Dept. E-2 P.O. Box 1653, Scottsdale, Arizona 85252 Tell me how to clean up with newly designed SUKII instant steam cleaning machine!

- Here's a check or m.o. for \$259.50—rush me demonstrator machine (\$479.50 retail value) and moneymaking details.
- Tell me how to get started as SUKII dealer.
- How do I qualify for that EXCLUSIVE FRANCHISE and PROTECTED TERRITORY as a SUKII distributor?

PHONE _____
NAME _____
SHIPPING ADDRESS _____
(Please do NOT use P.O. Box No.)
CITY _____ STATE _____ ZIP _____

At Last! A Full-Feature Workbench at an Affordable Price!



Made of solid rock maple, this extremely versatile 225 lb. workbench offers you a massive laminated 2" thick 30" x 60" work surface (a full 12½ sq. ft.). Bench comes complete with 2 extra large capacity/double-position vises that can be set either flush with bench surface or 1½" above, to act as a workstop for surface clamping. Vise faces are 18" long to clamp even the largest projects! A unique bolt and rod nut fastening system will hold bench rigid over years of hard use, yet can be disassembled should you need to move it.

Made in U.S.A.

Unlike imported benches, these benches are made in the U.S.A. and are shipped directly to you with no middlemen involved. This allows us to price our workbench far below others available. The Garden Way Home Workbench also offers you an exclusive LIFE-TIME warranty.

GARDEN WAY RESEARCH
Charlotte, Vermont 05445

To: Garden Way Research, Dept. 80122W
Charlotte, Vermont 05445

Please send me your free information about the New Garden Way Home Workbench including details on the build-it-yourself kits.

Name _____
Address _____
City _____
State _____ Zip _____

QUILT WORLD

- Everything you want to know about quilts and more!
- Over 120 Quilt patterns published annually!

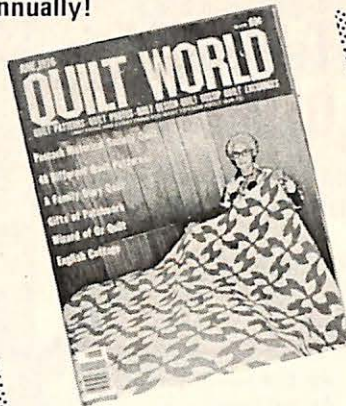

- Each issue packed with quilt patterns, quilt designs, quilt talk, quilt pictures, quilt news, quilt exchanges, quilt columnists, quilt letters, quilt book reviews, quilt contests!
- At least 120 quilt patterns published annually. (That's a little bit more than 3c per quilt pattern!)
- For all quilt devotees whether beginner or advanced!

You'll find every issue of "Quilt World" a refreshing, exciting trip into the delightful world of Quilts! Each issue bulges with Quilt Patterns, Quilt Photos, Quilt Diagrams, Quilt Gossip, Quilt News, Quilt Columnists, Quilt Contests, Quilt Letters, etc. etc! Truly a Quilt World for all those who love Quilts and Quilt making! In addition to dozens of wonderful Quilt patterns, you'll find outstanding Quilt Columnists. Then there is a contest for best Quilts! At least 120 Quilt patterns annually! We guarantee you must love "Quilt World" with the 1st issue, or we'll return your money back in full! Published bimonthly!

JUST \$3.50 FOR A FULL YEAR'S SUBSCRIPTION
(published Bimonthly)

Your Money Back

if the first issue you receive doesn't please you

QUILT WORLD
Box 337 T M Seabrook, N.H. 03874

1 year \$3.50 1 yr. Canada \$4.50
 3 years \$9.00 1 yr. Foreign \$6.00

Please Print Name & Address Clearly

NAME

ADDRESS

CITY STATE ZIP

Please allow 45 to 60 days to receive your first issue.

Elks Family Shopper



WELSH TWEED TRILBY wears so well in town or country. Jaunty, informal hat is crafted in the heart of Wales from the best Welsh Tweed in subdued olive brown dog's tooth or black and white dog's tooth. Fully lined; 1½" wide brim. Sizes 6¾ through 7¾. \$18.50 ppd. Send 25¢ for catalog. Austral Enterprises, P.O. Box 70190, Seattle, WA. 98107.



RELAX AND ENJOY reading and watching TV in bed with Folding Back Rest to support you comfortably. Plywood Rest is a big 16"x24" high; gives full pillow support to head and back. 6 positions. Cords hold pillow in place. Non-skid base. Folds wafer-thin for storage. \$12.98 pd. Better Sleep Inc., Dept. EL2, New Providence, N.J. 07974.



Lip smackin' fillets of Salted Mackerel

Caught in icy Atlantic waters, and cured in vats the "ole Gloucester way" to the peak of tasty delight. Five pounds of firm, meaty fresh-tasting fillets, flavor-sealed in a plastic pail with tangy brine

and shipped to you postage paid. Wide variety of sea food delicacies and gift assortments shown in free catalog. All unconditionally guaranteed. Post your order today to (no C.O.D. Please) \$12.00, add 50¢ West of Miss.

EMBASSY SEAFOODS, INC.

P.O. Box 268, Dept. E, Winthrop, Mass. 02152

YESTERYEAR TYPE SET



COINS GRADE GOOD OR BETTER ONLY \$6.50

The Yesteryear Type set includes an Indian Head Cent, Buffalo Nickel, Mercury Dime, Standing Liberty Quarter and Walking Liberty Half Dollar. Coins have been selected for clarity of design and detail. They are mounted in a plastic holder as shown.

\$1.00 U.S. SILVER CERTIFICATE \$3.75



None minted since 1957. A crisp, uncirculated \$1.00 Silver Certificate that will increase in value. Plastic holder included - ONLY \$3.75.

BOTH TYPE SET AND CERTIFICATE ONLY \$10.00

Add 50¢ postage. Catalog included. IMMEDIATE SHIPMENT. Satisfaction guaranteed.

Village Coin Shop

Dept. E, Plaistow, N.H. 03865

SATIN SLIPPERS

Glamorous slipper of satin brocade delicately woven with a glint of gold. Inside lush satin lining and quilted satin insole. Has the slightest wedge heel. In Champagne or Black. Available in full sizes 6-12 Med. Nar.



\$12
plus \$1.50 P&H

VICKI WAYNE-E2S
600 S. Country Club Rd.
Tucson, AZ 85716



UNUSUAL STAMPS

WORLDWIDE STAMPS, ONLY 10¢: Tonga Coconut Stamp, Space Station, American Bicentennial, Antelope, Bird, Fish, Olympics, Mini-stamp, Religious Painting, Flower. All of these worldwide stamps from far-away exotic lands for ONLY 10¢ when requesting approvals. Select those you like, return the rest. Cancel service anytime. Please state age.

DOUGLAS COOK, Dept. EL-1 Las Vegas, Nev. 89119



Amazoy is the Trade Mark Registered U.S. Patent Office for our Meyer Z-52 Zoysia Grass.

GRASS SEED WILL NEVER GROW A LAWN LIKE THIS—DROUGHT & WEAR RESISTANT! Amazoy lawns take cookouts, parties. Children playing on it won't hurt it or themselves! Stays green right thru scorching heat and drought!

Grass Seed Is For The Birds! Zoysia Saves Time, Work, Money

SPECIAL INTRODUCTORY OFFER. UP TO 200 AMAZOY ZOYSIA GRASS PLUGS FREE

By Mike Sandin

Every year I see people pour more and more money into their lawns. They dig, fertilize and lime. They rake it all in.



They scatter their seed and roll and water it. Birds love it! Seeds which aren't washed away by rain give them a feast. But some seed grows, and soon it's time to weed, water and mow, mow . . .

until summer comes to burn the lawn into hay, or crabgrass and diseases infest it. That's what happens to ordinary grass, but not to Amazoy Zoysia.

"MOWED IT 2 TIMES," WRITES WOMAN
For example, Mrs. M. R. Mitter writes me how her lawn ". . . is the envy of all who see it. When everybody's lawns around here are brown from drought ours just stays as green as ever. I've never watered it, only when I put the plugs in . . . Last summer we had it mowed (2) times. Another thing, we never have to pull any weeds—it's just wonderful!"

And from Iowa came word that the state's largest Men's Garden Club picked a Zoysia lawn as the "top lawn—nearly perfect" in its area. Yet this lawn had been watered only once all summer up to August!

CHOKES OUT CRABGRASS

Thick rich, luxurious Amazoy grows into a carpet of grass that chokes out crabgrass and weeds all summer long. It will NOT winter kill. Goes off its green color after killing frost, regains fresh new beauty every Spring—a true perennial!

For Slopes, Play Areas, Bare Spots

End erosion of slopes with Amazoy. Perfect answer for hard-to-cover spots, play-worn areas.

NO NEED TO RIP OUT PRESENT GRASS PLUG AMAZOY INTO OLD LAWN, NEW GROUND OR NURSERY AREA

Just set Amazoy plugs into holes in ground like a cork in a bottle. Plant 1 foot apart, checkerboard style.

When planted in existing lawn areas plugs will spread to drive out old, unwanted growth, including weeds—from part shade to full sun. Easy planting instructions with order.

Your Own Supply of Plug Transplants

Established Amazoy gives you Zoysia plugs to plant in other areas as desired!

PATENTED STEP-ON PLUGGER IS **FREE** WITH ORDERS OF 600 PLUGS OR MORE

Amazoy exclusive! No one else can offer you this patented 2-way plugger. Saves bending, time, work. Light, rugged, invaluable for transplanting. Cuts away competing growth as it digs plug holes.

Cuts Your Work, Saves You Money

Your deep-rooted, established Amazoy lawn saves you time and money in many ways. It never needs replacement . . . ends re-seeding forever. Fertilizing and watering (water costs money, too) are rarely if ever needed. It ends the need for crabgrass killers permanently. It cuts pushing a noisy mower in the blistering sun by 2/3.

NO SEED, NO SOD!

There's no seed that produces winter-hardy Meyer Zoysia. Sod of ordinary grass brings with it the problems of seed, like weeds, diseases, burning out, other ills.

Meyer Z-52 Zoysia Grass Was Perfected by U.S. Govt.: Released In Cooperation With U.S. Golf Assoc. as a superior grass.

Order guaranteed Amazoy now, get your bonus plugs FREE. Your order will be delivered at earliest correct time for planting in your area.

We ship all orders the same day grass is taken from the soil, shipping charge collect via most economical means.

© Zoysia Farm Nurseries, 1978

**Every Plug
Guaranteed to Grow
In Your Area • In Your Soil**

- **AMAZOY WON'T WINTER KILL**—has survived temperatures 30° below zero!
- **AMAZOY WON'T HEAT KILL**—when other grasses burn out, Amazoy remains green and lovely!

Plug Amazoy into an entire lawn or problem areas. Plug it into poor soil, "builder's soil," clay or even salty, sandy beach areas. I guarantee every plug, regardless. Any plug failing to grow in 45 days replaced FREE. Since we're hardly in business for the fun of it, you know we're 100% sure of our product!

If it isn't Amazoy, you're not getting the plugs that made Zoysia famous.

TO: Dept. 518 Zoysia Farms Nurseries,
(Our 23rd Year) General Offices and Store
6414 Reisterstown Road, Baltimore, Md. 21215
Please send me guaranteed Amazoy as checked below:

<input type="checkbox"/> FULL SIZE PLUGGER \$495	<input type="checkbox"/> 100 PLUGS Plus Bonus of 10 FREE TOTAL 110 PLUGS \$695	<input type="checkbox"/> 100 PLUGS & PLUGGER Plus Bonus of 20 FREE TOTAL 120 PLUGS \$995
<input type="checkbox"/> 200 PLUGS Plus Bonus of 20 FREE TOTAL 220 PLUGS \$1120	<input type="checkbox"/> 200 PLUGS & PLUGGER Plus Bonus of 25 FREE TOTAL 225 PLUGS \$1375	<input type="checkbox"/> 300 PLUGS & PLUGGER Plus Bonus of 50 FREE TOTAL 350 PLUGS \$1775
<input type="checkbox"/> 600 PLUGS & PLUGGER Plus Bonus of 100 FREE TOTAL 700 PLUGS \$2795	<input type="checkbox"/> 1100 PLUGS & PLUGGER, Plus Bonus of 200 FREE TOTAL 1300 PLUGS \$3995	

I enclose \$ _____ Check _____ M.O. _____

NAME _____

ADDRESS _____

CITY _____

STATE _____ ZIP _____

L.L.Beantm

Outdoor Sporting Specialties

FREE
Spring
Catalog



128 fully illustrated pages featuring camping, fishing, hiking and canoeing equipment. Also includes practical, long-wearing apparel and footwear for the outdoorsman or woman. Many items of our own manufacture. Our 66th year of providing dependable, high-grade sporting specialties. All guaranteed to be 100% satisfactory or your money back.

SEND FREE CATALOG

Name _____
Address _____
City _____
State _____ Zip _____

L. L. Bean, Inc.
7101 Cedar St., Freeport, ME 04033

CROCHET WORLD

FOR ALL THOSE WITH CROCHET
IN THEIR HEARTS

- Over 100 crochet patterns
- during the year!
- Less than 4c a pattern!
- Crochet Patterns
- Crochet Designs
- Crochet Articles
- Antique Crochet Patterns
- Crochet Columnists
- Crochet Contests
- Crochet Exchanges
- Crochet Information
- Crochet News
- Crochet Photos
- Crochet Gossip



JUST \$3.50 per year

CROCHET WORLD
Box 337 P, Seabrook, N.H. 03874

Mystery Electronic Top

Greatest New
Gadget
In Years.



Handsome
Gift Box

A Look into the Future!
Spins for days on Invisible Power

What Makes It Go On and On and On at 2500 r.p.m. with no apparent energy source? **BAFFLING BRAIN BUSTER** the **BUGS** the **BRIGHTEST**. Demonstrated at science fairs and conventions. The higher their IQ the more puzzled they are. Perpetual Motion solved at last? The answer to UFO & Flying Saucer? Let the whiz kids examine it, start it, stop it or whatever. Psychic Power? Anti-Gravity? (Yes, but more). Scientific Break-thru from Space? (Partially) You'll laugh at some explanations. Magic, Mystery & Science combined. Keeps spinning **WITHOUT ANY ENERGY LOSS!** Fascinating fun at parties, science classes, etc. Carry in pocket ready to fool and entertain friends & wise-guys. Never wears out. Spins indefinitely on Invisible Wireless Power that you can defy anyone to See, Understand or Explain! Beautifully made with plastic base and black saucer shaped spinner. Patented. Complete with secret scientific explanation. Orders shipped same day received. Unlimited Money Back Guarantee. Send check or money order for \$7.95 each. Add \$1.00 shipping. Save Get 3 for \$22.65 postpaid. 6 for \$43.00 postpaid. Dealer Inquiries Invited

Johnson Smith Co., 35075 Automation Dr.
Dept. 732, Mt. Clemens, Mich. 48043



Cheney.
Because
Carol loves
this house.

Carol's illness prevented her from climbing these stairs like she used to. She could move to a one-story house, but she loves this house. A *Cheney Wecolator*TM solved Carol's problem by letting her ride from floor to floor quickly and comfortably. As the first stairway elevator to be UL-listed, it's virtually maintenance-free and can be installed in just a matter of hours. For a colorful brochure on *Cheney Wecolators*, or *Wheelchair Lifts* and *Wheelchair Van Lifts*, contact your local Cheney Representative or write: The Cheney Company, Dept. EM, 3015 S. 163rd Street, New Berlin, WI 53151. (414) 782-1100.

Helping people help themselves.
CHENEY Wecolators.

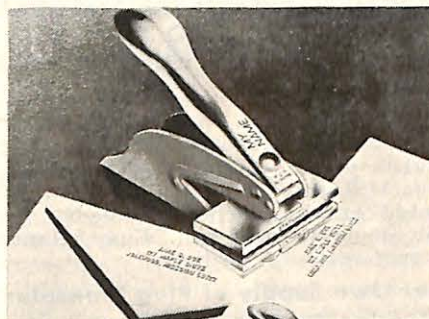

highly prized for any
gift-giving occasion

"MY NAME" EMBOSSER
converts envelopes and plain paper into expensive-looking raised-letter stationery. All steel lifetime construction—no maintenance. Highly prized for any gift-giving occasion including holidays, birthdays, etc. Limit 24 characters and spaces per each of 3 lines.
\$9.95 plus \$1 2 for \$19.50 plus postage 4 for \$38.00 \$2.00 post.

If 4 line name and address is required, add \$1.25
Desk Model: Add \$1 each embosser
Washington residents: Add 5% sales tax

Oliver A. Kastel 3106KF N.E. 53rd Street
Vancouver, Wash. 98653



LAST U. S. SILVER COIN SETS

Never again will silver be used in coin mintage! Most has already been remelted so these **UNCIRCULATED** coin sets will increase in value yearly! 1964-\$5; 1963-\$5.75; 1962-\$6; 1961-\$6.50; 1960-\$7. All 5 sets \$28.50 (mounted in lifetime holders). M/C & BOA (VISA) accepted. Add \$1.50 for ins. & hndlg. Centre Coin Co., Box 1, Dept. K-2, Sherman Oaks, Calif. 91413.

Elks Family Shopper



YOU'LL LOOK TALLER in handsome shoes by Elevator[®]. These extraordinary height-increasing shoes can make a man look almost 2 inches taller and no one will notice his secret. Elevators come in a wide variety of styles, all shown in a free color catalog. Write Richlee Shoe Company, 98 A. Lake St., Brockton, Mass. 02403.

100 WORLDWIDE 10¢ STAMPS ONLY

GET OUR NEW, VALUABLE COLLECTION OF 100 ALL DIFFERENT STAMPS FROM THE WORLD OVER
- New Countries, new commemoratives, new pictorials, scarce older issues. Montreal Olympics, Africa's Dr. Schweitzer, war-torn Angola, U.S. Champions of Liberty; PLUS MANY MORE. Mint and used - small and giant-sized. Also stamp selections to examine. Buy any or none. Return balance. Cancel service anytime. Send 10¢ today for this spectacular collection.

GARCELON STAMP CO.,
Dept. 2EMV, Calais, ME 04619

If Ruptured TRY THIS OUT

Modern Protection Provides Great Comfort and Holding Security

An "eye-opening" revelation in sensible and comfortable reducible rupture protection may be yours for the asking, without cost or obligation. Full details will be sent you Free. Here's a Support that has brought joy and comfort to thousands—by releasing them from Trusses that bind and cut. Designed to securely hold a rupture up and in where it belongs and yet give freedom of body and genuine comfort. For full information—write today! **WILLIAM S. RICE, Inc., ADAMS, N.Y., 13605 DEPT. 13T.**

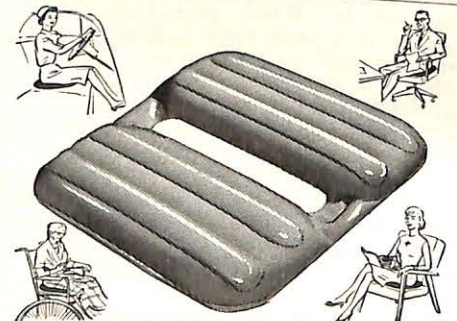

COMFORT CUSHION

New Twin-Rest Seat Cushion gives blessed relief to sensitive areas. Fights fatigue and soreness. Avoids side-rocking and maintains balance because each half inflates separately with contact-free center space. Unlike embarrassing "ring cushions", it fully supports each thigh independently. Deflates for travel. Ideal for car, home, office, sports, wheelchair. Handsome vinyl 16x17"—\$6.95 Green percale zipper cover—\$2.49 extra. Order from this ad, we'll pay postage, ship promptly. NJ residents add 5% tax.

Send Check or Money Order to —
Better Sleep Inc. MONEY BACK GUARANTEE
QUALITY PRODUCTS SINCE 1951
Box ER, New Providence, NJ 07974

ASTRONAUT GORDON COOPER ANNOUNCES:

**Now! CONVERT AIR INTO ENERGY—
EXPLODE IT LIKE FUEL—and
GET up to 7 MORE MILES PER GALLON!**

Yes, save up to \$18 a month, save up to 350 gallons of gas each year, save up to 2 full gallons every 60 minutes you drive — ALL FREE — because air costs you not one single penny!

Proven in the labs — proven on the road — proven by California university scientists: How it is now possible to convert air into energy 2,000 times a minute — boost gasoline mileage by as much as 7 more miles per gallon . . . actually drive up to 500 miles on a single tank of gas . . . all without changing a single part in your car!

The result: Instead of filling your gas tank each and every week . . . your car's engine now converts ordinary air into piston-driving power . . . explodes it just like a second source of FREE fuel . . . and saves you up to 350 gallons of gas, (over \$200 worth), each and every year!



by Col. Gordon Cooper, Astronaut, Engineer, Research Advisor

Brace yourself, Mr. Car-owner! Get set — for this incredible release — this "bombshell" announcement every automobile driver has been waiting for. News of a fantastic new era in automotive history. An era of mileage miracles where you can take even a 10-year old car and blaze across 6 states of the union on a single tank of gas — drive from New York to Chicago on less than 2 tankfuls — actually squeeze out "impossible" mileage figures of as much as 31, 35, even 47% more miles a gallon . . . as reported by actual "in-traffic" usage runs. Yes, save up to 30 gallons of gas each month, up to 350 gallons of gas each year, save up to \$200 OR MORE on yearly fuel bills — step up gasoline mileage by as much as 5, 6, even 7 MORE MILES PER GALLON. All by simply converting ordinary air into a second source of high-powered energy . . . with just a simple, 60-second change that even a schoolboy can do!

I'VE ACTUALLY SEEN A CAR WITH OVER 200,000 MILES BOOST GASOLINE MILEAGE BY 7 MORE MILES PER GALLON — WITH JUST THIS ONE 60-SECOND CHANGE!

Yes, from this day on you are going to do to your car what automotive experts now do to their cars. You are going to do to your car what California university researchers have proven time and time again. You are going to take ordinary air — the very same air you breathe — air that costs you absolutely nothing — and you are going to convert that air into a source of piston-driving power for your car . . . get such staggering boosts in mileage, horsepower and performance. You may only have to: **FILL YOUR GAS TANK AS LITTLE AS ONCE A MONTH!** Here's how:

STOP RUNNING YOUR CAR ON 12¢ EXPLOSIONS!

Right now your car runs on a very simple principle. You step on the gas-pedal and pump an air-gas mixture from your carburetor into your cylinders. There, a spark explodes it. This air-gas explosion is the lifeblood of your car. Only there's one trouble. Even though you invest as much as 65¢ to 70¢ for each gallon of gas . . . all you get in return is as little as a puny 12¢ explosion . . . a mere 12¢ worth of usable power. Because most of that air-gas mixture never fully explodes . . . in fact, never even warms up.

And if you want to prove this to yourself, simply take a wad of cotton, hold it next to your exhaust pipe and idle your engine. What happens to that cotton in the next 2 minutes will absolutely shock you. Because in less than 2 minutes that cotton ball will be damp and clammy from wasted, unused gas. Why this incredible waste?

LOOK HOW EASY IT IS!

All you do is simply slip the TURBO-DYNE ENERGY CHAMBER onto the line leading from your engine to your carburetor and simply screw into place. (As simple as screwing in a lightbulb). Why it's so easy and so quick that even a schoolboy can do it. In fact, even if you never lifted the hood of your car before it takes but 60 seconds to install. (Naturally, easy 1 — 2 — 3 step-by-step instructions accompany each unit). And since it is a precision instrument, there are no special adjustments for you to make. They've already been made for you at the factory. Total time to install — 60 seconds. Total savings on gas: up to \$200 a year.



SPECIAL NOTE: The "TURBO-DYNE ENERGY CHAMBER" — is not for use on fuel injected, diesel or super-charged cars (such as Mercedes, Volvo and Maserati racing car).

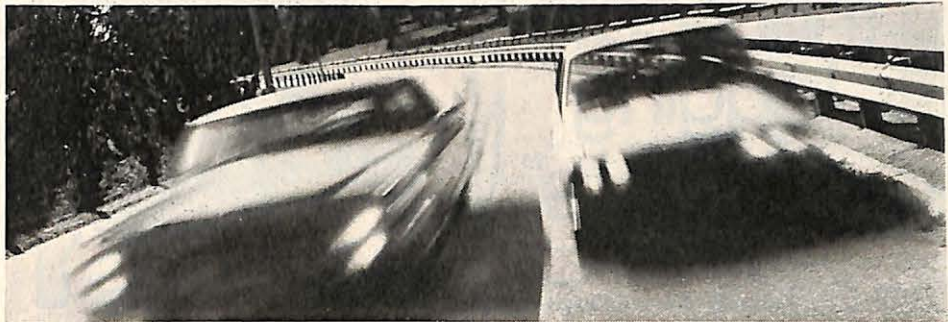

THIS 1968 CADILLAC GETS BETTER GAS MILEAGE THAN THIS TINY FOREIGN "ECONOMY" CAR . . . SO CAN YOUR CAR TOO! What's the secret? AIR! That's right . . . Now thanks to an amazing automotive discovery you can actually convert air into piston-driving power, so that instead of relying on gas alone you can simply step on the accelerator and turn air into energy while you drive. For documented proof of just how this wondrous "Air-to-Energy" discovery can save you up to \$200 in gas bills in the next 12 months alone . . . read the rest of this page. See no-risk trial offer below. (Test performed by leading research University).

WHAT DO YOU EXPECT FROM A MACHINE THAT'S GOT THE POWER OF A GIANT BUT THE MIND OF AN INFANT!

Because as any automotive engineer will tell you, your carburetor, (which was invented in 1901 and hasn't been improved since then), is nothing more than an old-fashioned pump without a mind, without a brain. It cannot think. It cannot regulate itself to varying driving speeds. It only knows one thing. Blindly pump — pump — pump a steady flow of gas all the time . . . BUT WITHOUT EVER ADJUSTING THE RIGHT AMOUNT OF AIR. Which means, every time you step on that gas-pedal . . . be it at idle or 70 miles per hour . . . your "midget-mind" carburetor pumps and force-feeds your engine with up to 4 TIMES AS MUCH GASOLINE AS IT ACTUALLY NEEDS . . . BUT STARVES YOUR ENGINE OF THE OXYGEN-RICH AIR so vital to explode all that gasoline. The result of this "over-drowning" with too much gas and too little air? A difference of as much as 2 GALLONS OF GAS EVERY 60 MINUTES YOU DRIVE! (or in plain dollars and cents a difference of as much as \$1.50 a day — \$10.00 a week — \$300.00 to \$500.00 a year).

BUT WHAT A DIFFERENT STORY IF SOMEHOW YOUR ENGINE COULD THINK!

In other words, right now there is simply no way for your present "no-brain" engine to effectively meter the right amount of air coming into your engine . . . and convert the oxygen in that air into a super-blazing source of extra power . . . by effectively exploding all the fuel fed into your cylinders (the same way jet airliners are now economy-designed to scoop in air with their giant suction-fan engines).

BUT NOW — YOU GET SO MANY FREE, EXTRA MILES YOU CAN ACTUALLY SAVE UP TO 2 GALLONS OF GAS EVERY HOUR YOU DRIVE!

But suppose that automotive experts told you that NOW, without changing a single part in your engine . . . by simply adding one simple attachment to your car . . . the very same wonder-invention that has been tested in Governmental research labs . . . you could add a "brain" to your engine . . . a mechanical genius that would automatically feed to your engine the right amount of air. Even more significant, suppose these same automotive experts showed you laboratory PROOF . . . PROOF that has been filed with both State and Federal Government agencies of how this wondrous new invention actually helps CONVERT THE OXYGEN IN THAT AIR INTO RAW, BLAZING POWER PLUS FREE EXTRA MILES PER GALLON mile after mile! Why, do you realize what this breakthrough development means?

NOW! FINALLY POSSIBLE! UP TO ALMOST TWICE THE MILEAGE ON NOT A SINGLE EXTRA DROP OF GAS!

It means that from this day on you can actually take ordinary air . . . and convert it to a second source of power for your car. Yes, gallons and gallons of air suddenly turned into thousands of miles of FREE driving power. Air that costs you absolutely nothing, automatically converted into SUPER BLAZING HORSEPOWER day in, day out for the life of your car! Why now you'll save up to \$18 a month on your gas bills. Now you'll drive for hundreds of miles at a time and swear to yourself the needle on your gas gauge must be stuck . . . and you'll get more power, more smooth and quiet performance than ever before thanks to this air-to-energy discovery!

NOW! CONVERT AIR INTO ENERGY — GET FOREIGN CAR ECONOMY — EVEN FROM BIG LUXURY SEDANS — MORE MILES PER GALLON THAN YOU EVER DREAMED POSSIBLE!

The name of this breakthrough development that finally makes it possible for you to effectively convert air into energy is the "TURBO-DYNE ENERGY CHAMBER". It is the very same "air-converter" that has been tested and proven in leading university labs. Tested and proven by fleet owners, industrial giants, consumers and heads of transportation departments where it racked up incredible mileage savings of as much as 40% more miles per gallon!

So, if you are sick and tired of wasting hundreds of gallons of gasoline each year . . . if you would like to stop this ridiculous dollar-drain ONCE AND FOR ALL by simple harnessing the power in ordinary air and saving hundreds of dollars doing it . . . then take advantage of this exciting no-risk trial offer:

COSTS LESS THAN A TANKFUL OF GAS — PAYS FOR ITSELF IN LESS THAN 30 DAYS!

Most exciting of all, the price of the TURBO-DYNE ENERGY CHAMBER is not the \$40 or \$50 you might expect for a precision air-converter but only \$12.95 . . . less than the cost of a tankful of gas. And you'll easily save as much as 10 times that price in just the first few months of use.

REMEMBER — YOU PROVE IT YOURSELF ENTIRELY AT OUR RISK!

Yes, you must save up to \$18 worth of gas each and every month — save up to \$200 in fuel each year — you must get at least up to 7 MORE MILES PER GALLON — or your money refunded in full (except for postage and handling, of course).

© 1977 American Consumer, Inc., Caroline Road, Phila., PA 19176

MAIL NO-RISK COUPON TODAY

Pratt-American, Dept. JTDF-19
Caroline Road, Philadelphia, PA 19176

Amount enclosed \$ _____ PA residents add 6% sales tax. Check or money order, no CODs please.

CHARGE IT: (check one) Exp. Date _____

BankAmericard/Visa American Express

Master Charge Bank Number _____

Credit Card # _____

Name _____

Address _____ Apt. # _____

City _____ State _____ Zip _____

Make of Car _____ Year _____

Make of Second Car _____ Year _____

3760-006

Div. of American Consumer, Inc.



"You bet I like cutting my jogging time by 75% in any weather—even snow, rain, cold and darkness.

"I compress the benefits of an hour of outdoor jogging into an easy 15 minutes indoors, simply by jogging on a scientifically designed inclined 'treadmill'.

"I jog in private, in the comfort of my own home—regularly, so it'll really do me good.

"And I build up my heart and lungs, and shed excess weight—to look, feel and sleep better, and help get a new lease on life.

"I jog on equipment that's used in health clubs and gymnasiums across the country—precision equipment that's built to last—the Battle Creek Health Walker."

Battle Creek Equipment Company, Dept. 12N
307 W. Jackson St., Battle Creek, Mich. 49016



Yes—I'd like to find out how I can own a Battle Creek Health Walker and jog to my heart's content for just pennies a day. Please rush full details with no obligation to buy to:

Name _____
Address _____
City _____ State _____ Zip _____

OUR FAMOUS CLYDESDALE'S ON PARADE

ORDER

BY

MAIL!



Our authentic cast iron Beer Wagon is a classic replica/investment for the collector. 8 chunky cast iron Clydesdale horses pull a vividly hand-painted wagon with 27 individual wood barrels. Complete with drivers, reins and Dalmatian dog. 31" overall. Weighs 16 lbs. Looks striking on a Bar, Mantlepiece or Television set. Makes a perfect gift. Although similar wagons sell for \$70-\$80 in gift shops, our price is: \$29.95 ea. plus please add \$3.00 for shpg. Mass. residents please add 5% sales tax.

*** SPECIAL PREMIUM OFFER ***

Clip this ad and send it with your order and we will send you FREE a set of BUDWEISER salt and pepper shakers.

Send your check to: (If Master Charge or Visa, card No. & exp. date)

HIGHLANDER HOUSE

70 Main St. (617) 665-3581
MELROSE, MASS. 02176

Elks Family Shopper

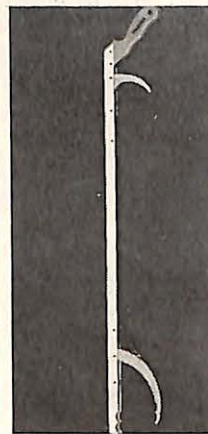

YOU'LL HAVE A LONG REACH with handy Reacher to help. It has a 31-inch reach with hand-controlled clamp and a magnet on the end to pick up metal items. Now you won't have to stand on wobbly chairs to get things on the top shelf. Very handy for arthritic persons. \$11.50 ppd. N.J. res. add 5% sales tax. Comfort-Able-Aids, Box 275y Somerset St., Paritan, N.J. 08869. Send for free self-help catalog.

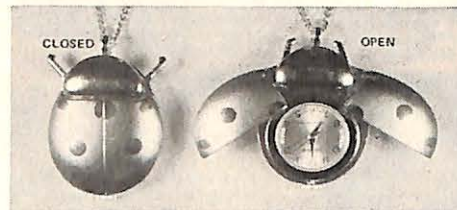

LADYBUG PENDANT WATCH

Closed, it's a lovely ladybug. Push the top and the wings open to reveal a fine, feminine watch with sweep second hand. This beautifully original creation comes complete with neck chain. Choose silver or goldtone. 2-yr. guarantee.

NEW Penguin pendant watch—wings open like ladybug watch. Black-white or blue-gold. Same guarantee. \$19.95 + \$1 ptg.-ins. or \$2 via air mail-ins. Color catalog 50c

Oliver A. Kastel 3106KF N.E. 53rd St.
Vancouver, Wash. 98663

GREENHOUSES

from \$88⁹⁵!

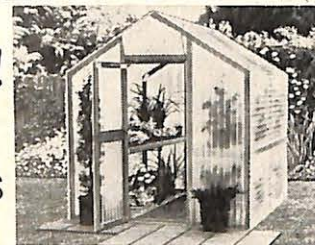

Uses up to 40% LESS HEAT !!

All-bolted California Redwood and Fiberglass. Portable. Write to McGREGOR GREENHOUSES, Box 36-B2, Santa Cruz, CA 95063. (408) 476-5390

See Advertisement Inside Back Cover

SATISFACTION GUARANTEED OR MONEY BACK
OLD VILLAGE SHOP

Dept. M3470, Hanover, Pa. 17331

Sure, I'll try the world's most comfortable shoes.

Please send me:

..... prs. Men's Tan Leather
..... prs. Men's Sand Sueded Leather
..... prs. Men's Brown Sueded Leather
(M242578B) Size _____ Width _____
(M233381B) Size _____ Width _____
(M242584B) Size _____ Width _____

for just \$14.99 pr., plus \$1.50 per pr. postage and handling. If they are not the most comfortable, the finest quality pair of shoes I've ever owned, I may return for a full refund of purchase price, no questions asked.

SAVE MORE! Order TWO pair for just \$28.99 plus \$2.75 postage and handling.

CHARGE IT

AMERICAN EXPRESS
 BANKAMERICARD
 CARTE BLANCHE
 DINERS' CLUB
 MASTER CHARGE Interbank No. _____

Acct No. _____ Date Expires _____

C.O.D. Enclose \$2.00 deposit per pr.

Enclosed is _____

NAME _____ (please print)

ADDRESS _____

CITY _____

STATE _____ ZIP _____

Elks Family Shopper

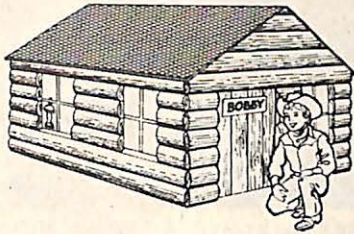

GIANT FRONTIER CABIN holds 2 children, 3 ft. high, 9 sq. ft. (approx.) cabin has 23 cubic ft. of space inside. Waterproof polyethylene. No tools needed; folds for storage. \$3.95 ea.; 2/\$5.95. Add \$1.00 pstg. per cabin. Available for girls, Giant Playhouse, same price. Giant Cabin Co., 165 Sutton Ave., Box 143, Dept. 69, Oxford, Mass. 05140.

STOP STOOPING!

with amazing, new



Shoulder Brace

Corrects posture instantly, comfortably. Provides even distributed support for sagging shoulders. Improves appearance, gives you a wonderful new feeling of confidence. No fitting. Made of highest quality ventilated-for-comfort 3-ply cushioned material. Arm bands softly padded.



From this . . . to this in 20 seconds

FOR MEN AND WOMEN. Can't be detected under light clothing. Give measurement around chest. \$6.95 plus 75¢ postage. Money-back guarantee if returned post-paid in 30 days.
PIPER BRACE CO., Dept. EK-28SH
811 Wyandotte, Kansas City, Mo. 64105



Patented



World's Rarest Stamp \$350,000!

Receive a full color reproduction of the 1856 1c British Guiana, on a genuine postage stamp, plus story of how it became more valuable than gold or diamonds! Included is a jumbo collection of genuine postage stamps from 77 different countries—new issues, 19th century, airmails, commemoratives, moon & outer space and much more. All just 10c! You'll also receive other exciting stamps on approval. Buy any or none, return balance, cancel service anytime. The world's rarest stamp reproduction and 77 countries are yours to keep! **HARRIS, Dept. RS-59, Boston, Mass. 02117**



REMOVE HAIR FOREVER

Perma Tweez electrolysis safely and permanently removes all unwanted hair from face, arms, legs and body. No-puncture safety feature—clinically tested and recommended by dermatologists.

14 DAY MONEY BACK GUAR.

\$19.95—send check/M.O.

Cal. residents add 6% sales tax

- I enclose \$4.00 deposit and will pay balance COD plus extra COD charges.
- I enclose \$19.95 in full payment.
- BankAmericard/Master Charge #/Exp. date

GENERAL MEDICAL CO., Dept. E-29
1935 Armacost Ave., W. Los Angeles, CA 90025



LIMITED WARRANTY TO CONSUMER'S PROMISES
REPLACEMENT OR REFUND IF DEFECTIVE

©1977 GENERAL MEDICAL CO.

TRY THIS NEW PIPE "FREE" FOR 30 DAYS!

So different that it's patented by the **UNITED STATES GOVERNMENT**
patent number 3267941

"MAGIC INCH"

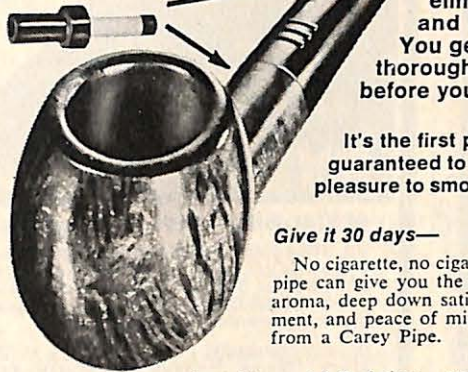

This top grade Mediterranean briar incorporates a sensational invention that contradicts every idea you've ever had about pipe smoking. It completely eliminates breaking-in. Tars, sludge, bite, and bitterness never reach your mouth. You get cleaner, cooler, tastier, moisture-free thoroughly enjoyable smoking. You can try it before you buy it.

E. A. Carey

It's the first pipe in the world that's guaranteed to give unadulterated pleasure to smokers.



Give it 30 days—

No cigarette, no cigar, nor any other pipe can give you the full rich flavor, aroma, deep down satisfaction, enjoyment, and peace of mind that you get from a Carey Pipe.

You may be a pipe smoker with a rack full of pipes and still searching for the ideal smoke, or perhaps you would like to switch to a pipe to cut down on cigarettes or expensive cigars.

The Carey Pipe may look like any ordinary pipe, but it's a lot different! In fact, there's nothing like it in the whole world! The Carey Pipe is made of the finest aged mediterranean briar—but, its big secret lies in the exclusive patented "MAGIC INCH," cleverly concealed in a bite proof nylon stem.

Not My Magic But Nature's Own Magic

There are no gadgets, no traps, no coils, no filters, no baffles, no tricks, no moving parts YET: the "Magic Inch" harnesses four of nature's laws. It creates a VACUUM which draws in and mixes with the smoke a metered quantity of cool oxygen. It causes CONDENSATION which squeezes out excess moisture, and DRIES the smoke before it reaches the mouth. It employs CAPILLARY ATTRACTION to absorb precipitated moisture and prevent formation of sludge and goo. It promotes EVAPORATION to further cool the smoke and throw off into the air the moisture that otherwise would form sludge. In addition it eliminates "BREAKING IN". From the very first pipeful down to the last puff, the smoke is mellow and sweet with all bitterness and bite removed. No "breaking in" is needed with a Carey Pipe.

Today, over two hundred thousand pipe smokers

smoke Carey Pipes almost exclusively. They were all granted the same option, an option which is yours also. After 30 days, if you agree that the Carey Pipe is the best smoke of your life, you may keep it: if you don't agree, whack it with a hammer and return the broken pieces to me. The trial has cost you nothing! How many businesses are that sure of their product?

Make Your Own 30 Day Test

Fill in the coupon below and mail it to me TODAY. I'll send you a full color brochure, absolutely free, so you can select your favorite style and shape for your 30 day trial.

E. A. Carey, Dept. 204B
3932 N. Kilpatrick, Chicago, Illinois 60641
Okay Mr. Carey. Send me your full color brochure so I can select a pipe to smoke for 30 days on a free trial basis.

Name _____
Address _____
City _____
State _____ Zip Code _____

RADIO PERUNS

On Cassette Only \$2.98 Per Show!

Each 30 minute show as originally aired including commercials.

THE 20 BEST SHOWS EVER AIRED!

Buy 5 Get 1 Free!

Return to:
RADIO PERUNS
P.O. Box 11044
Dept. E
Mpls., MN 55411

12. ABBOTT AND COSTELLO—Incl. "Who's on First"—All Time Classic 6/18/44
28. AMOS 'N' ANDY — "Kingfish's Travel Bureau" 4/47
103. AMOS 'N' ANDY — "Marriage Go Round" — All Time Classic
126. BABY SNOOKS — "The Opera" — Voted Best of Series
32. THE BICKERSONS — Argument at breakfast/Bedtime on a fishing boat/Anniv.
33. BOB AND RAY — Best of Their Comedy Routines "Bits & Pieces"
129. BURNS AND ALLEN — "Gracie Has Laryngitis" — All Time Best
123. EDGAR BERGEN & CHARLIE MCCARTHY — "Last Show" — Collectors Item
18. JACK BENNY SHOW — Last Radio Show, 1955 — A Collectors Must!
20. W.C. FIELDS — "The Day I Drank a Glass of Water" — All Time Classic
99. CBS NEWS ROUNDUP — Pearl Harbor attacked 12/7/41 — Hist. Collect. Item
100. GOLDEN DAYS OF RADIO—B. Crosby, J. Benny, A. & Andy, L & Abner, B. Hope
46. THE GREEN HORNET — "A Matter of Evidence" — All Time Best Show
48. INNER SANCTUM — "Only the Dead Die Twice"
67. LIGHTS OUT — "Cat Wife" with Boris Karloff — voted best of series 1938
62. THE SHADOW — "Death From the Deep" w/Orson Welles — All Time Best Show
153. SUSPENSE — "Sorry, Wrong Number" — All Time Best Show 2/14/60
91. "WAR OF THE WORLDS" w/Orson Welles, 10/30/38 Part I
92. "WAR OF THE WORLDS" w/Orson Welles, 10/30/38 Part II
97. 50 RADIO COMMERCIALS — 5c Pepsi, Ovaltine, & more from early days of radio

TO ORDER: 1. Circle the "Numbers" of the shows you wish to order. 2. Clip Ad and return with \$2.98 for EACH show ordered. 3. Be sure to choose 1 FREE show for each five shows you order. 4. Add 85¢ for shipping and handling.

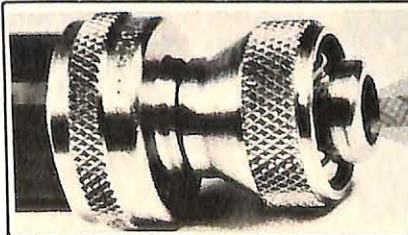

NEW! Adjust-A-Power Hose Nozzle

has 50% more power and lifetime leakproof guarantee. The ONLY adjustable nozzle with solid jet stream. Precision made of solid brass with stainless steel ball bearings. Easy fingertip control permits adjustable sprays: pin-point, fan spray, solid jet stream, or complete shutoff. No washer needed—ever! Ideal for patio, garden, auto, driveway, or industry. MONEY BACK GUARANTEE. Order direct from LARCH, Dept. 602-V, Box 770 Times Sq. Sta., New York, 10036, plus 45¢ shpg. & hdlg.

343

Silver Replating Sale 25-YEAR WARRANTY



FREE Dent Removal Offer from America's Largest Silverplater

Limited time only. Have antiques, heirlooms or any items **QUADRUPLE SILVERPLATED** at sale price. Gold, copper, brass, pewter refinished too. Missing parts replaced.

Senti-Metal Co.

Silverplating Division, Dept. EL2
1919 Memory Lane, Columbus, Ohio 43209

Write for **FREE PRICE LIST** Today!

Carry TEN TIMES a Wheelbarrow Load with INCREDIBLE EASE!

These BIG, strong carts are perfectly balanced on two huge wheels — roll easily over lawns and gardens — carry up to 400 lbs. of load — huge volume capacity means you make fewer trips — you'll save time and steps.

If you are still struggling with a wheelbarrow or inadequate cart (with tiny wheels) send for **FREE Cart Catalog**. Build-it-yourself kits, too.

GARDEN WAY RESEARCH, Dept. 80122
Charlotte,
Vermont
05445



FOG FREE

Prevents Fogging—Steaming on **SUN GLASSES**
WELDING MASKS • **RIFLE SCOPES** • **MOTORCYCLE**
SHIELD • **ALL GLASS & PLASTIC** • **TV SCREENS**
BATHROOM MIRRORS • **WINDOWS &**
ALL GLASS DOORS

FOG FREE is an approved eyeglass cleaner which prevents fogging and steaming. This specially formulated cleaner is also anti-static, repelling dust and lint. FOG FREE has been tested and approved on eyeglasses, optical lenses, plastic shields, diving and ski masks, welding mask, mirrors, car windows, dental mirrors, etc., etc. FOG FREE can be used as often as desired—it will not build up on any glass or plastic surface—even after repeated use. FOG FREE is effective, economical, and convenient. It's packaged in unbreakable 7 dram containers with convenient snap lids. One jar will last a year for a pair of glasses. One jar will last a year for an average size car's windows. One jar will last a year for a bathroom mirror. Do Not Use On Contacts. FOG FREE has no silicones—no harsh chemicals—no abrasives—no odor.

1 jar, \$3.00 plus 55¢ shpg.; 2/\$5.00 plus
60¢ shpg.; 3/\$7.00 plus 65¢ shpg.
FOG FREE P.O. Box 4506,
Florence, S.C. 29501

**"SAVE
YOUR
HEART"**

with a
STAIR-GLIDE® Stairway Elevator

RENTAL-PURCHASE Program Available

Your STAIR-GLIDE® installs easily and in less than 2 hours. No marring walls or stairway. No special wiring required. Shipped directly from factory within 4 days. STAIR-GLIDE®...the nation's largest selling stairway elevator! UL LISTED.

USED BY THOUSANDS: CARDIAC PATIENTS, ARTHRITIS, SENIOR CITIZENS, PHYSICALLY RESTRICTED, POST OPERATIVES...and household convenience.

WRITE FOR FREE BROCHURE AND NAME OF DEALER NEAREST YOU.

AMERICAN STAIR-GLIDE® CORP.
4001 East 138TH ST., Dept. E-28
Grandview, Missouri 64030

MIGHTY 4-OZ. POCKET SCOPE

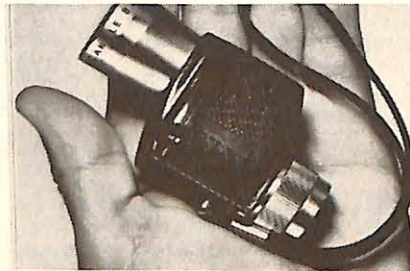

A miracle 8 power—with the panoramic view of a full-size binocular! The magic of powerful optics at your fingertips wherever you go. The 8 power Bushnell (Bausch & Lomb) Pocket Scope is great for travel, hiking, nature study, spectator sports, and theatre. 437° field at 1000 yards. Use lens 24 mm by itself as a close-up magnifying glass to study stamps, coins. Use for many other fascinating adventures. 3½" long, weighs only 4 oz., fully coated lenses. Complete with handsome zippered carrying case and wrist strap. Only \$29.95 plus \$2.00 p&h. Great Gifts.

Send Check or M.O. 15 day money back guarantee.

J. W. Holst, Inc. Dept. EK-28, 1864 E. US-23
East Tawas, Michigan 48730



Superior.

The Mason & Sullivan
Clock you build.

The finest woods and imported movements distinguish Mason & Sullivan's 19 different styles of floor, wall, and mantel clocks—all replicas of classic antiques. Send \$1 for catalog and plans to build grandfather clock shown, or 50¢ for catalog alone to:
MASON & SULLIVAN CO.
Dpt. ELF8/39 Blossom Ave.
Osterville, Mass. 02655.

Elks Family Shopper



WANT TO START A MAIL ORDER BUSINESS? Mail Order Authority, G.M. Turk, offers instructions and a complete program. Send for his informative book, catalog, ads and details of his offer free of charge with no obligation. No salesman will call. Write to G. M. Turk, Mail Order Associates, Inc., Dept. 804, Montvale, N.J. 07645.

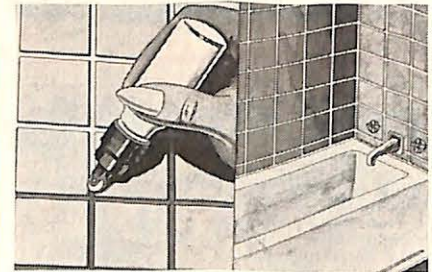

NEW LOOK FOR BATHROOMS. Bathroom and shower wall look sparkling new when you apply non-yellowing Tile Liner to whiten stained, discolored lines between wall tiles. Easy smooth-flow applicator makes precision lines. \$3.98 plus 85¢ shpg. Larch, Dept. EM-1, Box 770, Times Sq. Station, New York, N.Y. 10036.

MATH WITHOUT TEARS

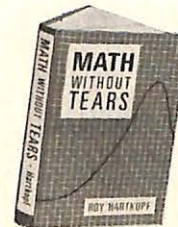

In lively non-technical language Roy Hartkopf gives you a basic understanding of many of the everyday applications of mathematics.

Emphasizing the practical aspects of math, the author avoids mathematical terms and jargon and takes the reader from simple counting to trigonometry and calculus.

MATH WITHOUT TEARS is written with a light touch and is filled with interesting anecdotes, spiced with humor.

Learn math in the comfort of your own home at minimum cost. **ORDER NOW:** \$7.95 plus 75¢ handling. 10-Day Money-Back Guar.

EMERSON BOOKS, Inc., Dept. 414-D
Buchanan, N.Y. 10511

ADJUSTABLE T.V. POLES

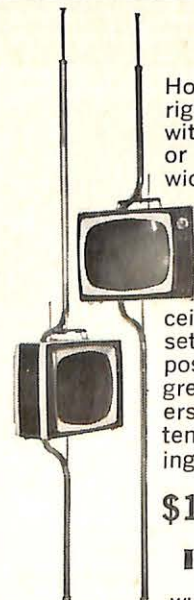

Hold your portable T.V. right where you want it, without awkward tables or stands. Takes any width, up to 14" deep.

17" high. Brass tone finish pole has spring tension rod to adjust to 7½ to 8½ ft. ceiling heights. Can be set up in Hi or Low position. Hi position is great for reclining watchers! Made in U.S.A. Extension for higher ceiling, add \$2.00.

Prompt Shipment
\$14.99 Plus \$1.00 postage

Write for **FREE** catalog

Holiday Gifts

Dept. 702-8A
Wheat Ridge, Colorado 80036



If you shouldn't climb stairs
INSTALL AN "Elevette"

"Elevette" — the modern home elevator — can carry three adults or a wheelchair patient and attendant. It's custom built to the size best suited for your needs and serves two or more floors of your home.

Tax deductible when recommended by a doctor.

SEND FOR FREE LITERATURE
Fully describes and illustrates "Elevette". Also, StairLIFT, the budget-priced, single-seat passenger lift for the stairs.

INCLINATOR COMPANY OF AMERICA
2204 Paxton St., Harrisburg, Pa. 17105
In business for over 50 years

REMBRANDT DID IT IN OILS...

Let us do it in **BRONZE PLAQUES**
FOR ALL OCCASIONS
Write for Free Catalog E23
Engraved Plaques E21



INTERNATIONAL BRONZE TABLET CO., INC.
150 W. 22nd St., N.Y., N.Y. 10011 212-WA 4-2323

NEW EQUIP. WHOLESALE 100% GUARANTEED

Commercial Refrigeration & Food Service Equipment. Ice Makers, Beer Systems, Refrigerators, Freezers, Commercial Stoves-Ovens, Deep Fryers, Grills, Mixers, Slicers, Pots & Pans, Carbonators, Walk-Ins, Meat Cases & Everything else for Kitchen, Bar, Restaurant or Supermarket service. Nationwide Sales! **FREE LITERATURE** and **PRICES**. Send specifications & details of equip. you need. **AMERICAN REFRIGERATION COMPANY**, Coaldale, Pa. 18218.



BINGO FOR FUND RAISING
EVERYONE HAS FUN!

No off nights when you use **BINGO** for your fund raising! Thousands of Organizations are making \$50 to \$500 per week using "**BINGO KING**" supplies with **FREE** Idea Bulletins. **PAY AS YOU GO.**



MAIL COUPON TODAY!

"BINGO KING"
Dept. 802B, Box 2588, Littleton, Colorado 80120

Yes, show us how BINGO can make money for our Organization.

Your name _____
Address _____
City _____ State _____ Zip _____
Name of Organization _____

Where The Action Is...
(Continued from page 42)

logue between the complainant and agencies or businessmen. The city, its agencies, and private concerns have been very cooperative in helping solve problems and right wrongs."

William Steven, who started all the action, had an interesting comment on the subject of cooperation from merchants when they are confronted with consumer complaints through the Action services.

"Most major corporations are very cooperative with Action editors," says Steven. "For example, Sears Roebuck was delighted to get our complaints. They said they wouldn't have known about them otherwise, and it gave them a chance to deal with issues their customers were concerned about. So the Action columns help promote a two-way or three-way communication between consumer, seller, and our type of consumer advocate."

"The newspaper is an information source which can be of great help to people with specific problems," says Steven. "A newspaper's Action service of usefulness to its readers can be beyond compare."

The same sense of usefulness and purpose is shared by many who conduct radio and television Action services.

"But television and radio aren't doing the Action service with the larger staffing of the newspapers," Steven maintains. "You need a staff of three or five people and they should all be good reporters and in many ways good detectives. A good Action service calls for a staff with a lot of moxie, to know how to get justice served."

"The Action column or program is basically a service, but there often is a lot of humanity to it, and you can have a lot of fun with it," says Steven as he recalls his favorite Action case from Houston:

"A man wrote in to 'WATCHEM' saying he lived in a boarding house. He was allergic to rabbit and thought his landlady was serving him rabbit but saying it was chicken. He asked us what to do."

"'WATCHEM's' answer was: 'Eat wings!'"

And so, from "Howdy Folks," the Action column in the *Times-Review* in Cleburne, Texas, to "Speak Up" in the *Daily Record* in Merrill, Wisconsin, and from "Help!" in the *Courier-News* in Somerville, New Jersey, to "Action Line" in the *Philadelphia Bulletin*, the name of the game, if you can't solve your own problem yourself or get satisfaction out of the system, is to call or write your local paper or radio or TV station's Action editor for some fast help. Unless you live in Moscow.

Let Belsaw prove YOU can
Earn Up To \$800 an Hour



In YOUR OWN SPARE TIME or FULLTIME SHARPENING BUSINESS!

On our 30-DAY FREE TRIAL OFFER

You risk nothing by accepting this offer to see how easily you can turn your spare time into big Cash Profits with your own Complete Sharpening Shop. No selling... no previous experience needed. Our famous Sharp-All and show-how instruction set you up to make \$200, \$500, \$700 a month CASH sharpening Saws, Knives, Scissors, Lawnmowers, Shop and Garden Tools... all cutting edges.



LIFETIME SECURITY with YOUR OWN BUSINESS

FREE BOOK! Gives Full Details

Send for all the facts! Our Free Book tells how to start a profitable, lifetime home sharpening business, how we help you grow, how we'll finance you!

Send for FREE details - mail coupon below or postcard TODAY!

BELSAW SHARP-ALL CO., 4214 Field Bldg., Kansas City, Mo. 64111

No Obligation... No Salesman Will Call

• YES, BELSAW, 4214 Field Bldg., Kansas City, Mo. 64111 •
• please send me the **FREE BOOK** that gives full details. •

Name _____ Please Print _____
Address _____
City-State _____ Zip _____



SAVE HUNDREDS OF DOLLARS

Possess the gem that's as brilliant as a diamond.

The incredible **MAGIC FIRE™** has more "fire" than a glittering natural diamond. Own the dazzling impact of diamonds that can easily sell for up to \$1,000 per carat — for a fraction of the cost. From \$35 a carat and set in 14K Solid Gold. Easy payment plan — bank credit cards. Send for our **Free** catalog of pendants, earrings, and rings for men and women.

MONEY BACK GUARANTEE
Guarantee available on request.

The Crown Collection Dpt. EL-2
509 Madison Ave, NY, NY 10022

ELECTRIFY YOUR BIKE!

PEDALPOWER exciting new bike drive tames tough hills. Be independent. Shop when you want. Fits all Bikes, Adult Trikes. Installs in minutes. Thousands sold. Recharges overnight. Travels 100 miles for a dime. Call or send for **FREE** illustrated booklet.



CALL FREE 800-257-7955

GENERAL ENGINES CO.
5670 Mantua Blvd., Sewell, N.J. 08080

The Woeful World

(Continued from page 10)

him as in these first weeks. The burden may get a little more weighty down the line. But the greater worry is that Carter, like others before him, will become uncomfortable in leisure.

"For more years than one cares to calculate, the inhabitants of the Oval Office have glorified in the myth of superhuman exertion. The more meetings, the more phone calls, the more crises, the longer the hours, the better it got. Lyndon Johnson, for instance, worked an early shift of eight hours, took a two-hour nap in the late afternoon, then stepped into a cold shower that pummeled him back to consciousness, after which he worked eight more hours. Richard Nixon by that measure was rather lazy, but he was so intimidated by his predecessor that his staff strove frantically to cover up the time he spent resting or brooding. . .

"For a few days there it looked like Jimmy Carter would restore balance. He went to work at the good country hour of 7:30 a.m. and got back home to dinner regularly at 6:30 p.m. He wrote his staff a memo saying that they needed rest and time with their families. Carter even opened up a little spare time in the mornings to think by himself. He went to the opera one Sunday afternoon and returned to Plains on a weekend to stroll along the main street."

Unfortunately, not many Americans are as serene as President Carter seems

to be. According to Warren Boroson, who has studied the workaholic, going on a family vacation with a workaholic can be a hellish ordeal, because free time makes the workaholic uneasy and anxious. One psychologist tells of the president of a midwestern company whose wife and daughter shanghaied him to Hawaii for three weeks on the beach. The man hadn't taken a vacation in 13 years. He made everybody so miserable by his compulsion to keep phoning the office that after four days his family was as frantic to get home as he was.

Is there a cure for workaholism? Yes, providing the victim wants to be cured. The age-old answer to the workaholic is the same applied to the alcoholic or the drug addict: he must want to be cured.

"It's crucial that the workaholic recognizes his problem or there's no place to start for getting well," says Dr. Hobart Mowrer, research professor of psychology at the University of Illinois. "If he takes an honest inventory of himself, his goals, his obligations to his family, and then revises his priorities, the workaholic has a departure point for re-ordering his life. I believe he has to develop a better self concept and an improved attitude toward himself. Hobbies and new interests can be helpful provided they don't become new obsessions."

What can a workaholic do to help himself?

Dr. Clark of Georgetown University, who we mentioned earlier, says we

should all place a greater value on relaxation during vacations, on weekends, and, most important, during the course of everyday life. He recommends spending a short time in meditation once or twice a day. He notes that many people prefer a formal system such as transcendental meditation, which involves repeating a personal mantra, or meaningless sound, for a period of 20 minutes, and others obtain similar results by slowly saying the Roman Catholic rosary; still others prefer to sit and stare at the bushes while their minds wander.

He has other tips to help achieve a more relaxed lifestyle: Don't program

all your free time. Spend at least one night a week at home. Take a lunch hour and coffee break without phone calls. A short break in routine, away from pressures, is tranquilizing. When you return from a leisurely afternoon, don't tackle a long list of projects or you'll lose what you have gained.

Hobbies or sports can be a fine means of relaxation, Clark says, as long as you don't turn them into mammoth projects. In other words, "putz around" in the garden but don't plan to weed all 10 acres at once.

Dr. Clark urges that people, whether on vacation or at home, recognize the worth of leisure time. "We need to realize that life is a balance between activity and being more passive," he says, shaking his head at what he calls "this business of wasting time." He recalls overhearing a student who lamented "wasting Sunday afternoon" watching a football game on TV. If the youth was relaxing, Dr. Clark contends, the time wasn't misspent.

Dr. Clark concedes that society, peers, and parents tout work instead of leisure. "We should recognize that these pressures are there, but as individuals we don't have to accept them."

Recently, Patricia Fanning, in a National Observer column called Survival Tactics, stumped for the formation of an organization to help workaholics. She wrote: "The name would be Workaholics Anonymous, and its meetings would be held on a beach or under a tree, any place far from traffic, jangling telephones, and whining children. Ideally, participants would straggle in without much regard to the time; maybe a few teetotalers would even leave their watches behind. Books, brief cases, and bags of needle-point would be banned. Harsh fines would be levied on anybody caught surreptitiously checking a pocket calendar.

"Once assembled, participants would be dispatched to spend the rest of the 'meeting' relaxing alone. They would learn how to sit for a bit without fidgeting, how to daydream, how to idle away some time without being overcome by guilt. Eventually members would be able to exercise this sort of will power right in their own environments. Cured of workaholic tendencies, they could turn down the buddy at the bar who sidles up, throws an arm around the shoulder, and offers a tempting committee post. Relaxing alone at home, they could be trusted to open a cabinet without becoming obsessed with a need to clean it out. -

"Too bad Workaholics Anonymous is only an imaginary organization. Those of us caught up in the work ethic need any help we can get to start relaxing. And it looks as though we're in for trouble if we don't learn how." ■



"You don't want to see me about basketball. . . you want my brother Looney. I'm 'Shorty'."

The World's Most Comfortable Shoe!

The Famous
CosmoPedic™

Not \$38

Not \$20

Here Only

\$14.99

Genuine Leather Smooth or Sueded

NOW! BLISSFUL COMFORT MORNING TO NIGHT! The closest thing to going barefoot! Handsomely-styled CosmoPedic shoes are the ultimate in comfort... and quality-crafted with features you'd expect to find in a \$20 or \$38 shoe! Luxurious genuine leather uppers in deer-tanned smooth or sueded leather are incredibly soft, yet amazingly shape-holding. The unique CosmoPedic arch support assures comfort thru long hours of standing or walking. A stitched collar prevents annoying chafing around the ankles. And for that walking-on-air feeling... cushioned insoles and plantation crepe soles pamper your feet from heel to toe! In Tan smooth leather; Brown or Sand sueded leather... just \$14.99!



Tan Smooth
Leather

MEN'S SIZES 6½, 7, 7½, 8, 8½, 9, 9½, 10, 10½, 11, 11½, 12, also 13 WIDTHS: C, D, E, EE, EEE

FAMOUS 14 DAY COSMOPEDIC GUARANTEE

Latest fashions, finest quality, great value—accurately described and promptly shipped.

If these CosmoPedic shoes are not the most comfortable, the finest quality pair of shoes you've ever owned, simply return them within 14 days for a full refund of purchase price, no questions asked. Now that's a guarantee in writing.

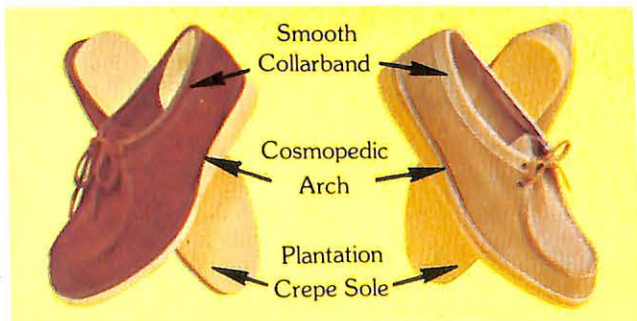

Brown Sueded Leather

Sand Sueded Leather



OLD VILLAGE SHOP
Hanover, Pa. 17331

SATISFACTION GUARANTEED OR MONEY BACK

OLD VILLAGE SHOP Dept. M-3470 Hanover, Pa. 17331

Sure, I'll try the world's most comfortable shoes. Please send me:

_____ prs. Men's Tan Leather (M242578B) Size _____ Width _____
 _____ prs. Men's Sand Sueded Leather (M233361B) Size _____ Width _____
 _____ prs. Men's Brown Sueded Leather (M242586B) Size _____ Width _____

for just \$14.99 pr., plus \$1.50 per pr. postage and handling. If they are not the most comfortable, the finest quality pair of shoes I've ever owned, I may return for a full refund of purchase price, no questions asked.

SAVE MORE! Order TWO pair for just \$28.99 plus \$2.75 postage and handling.

CHARGE IT AMERICAN EXPRESS DINERS' CLUB
 BANKAMERICARD MASTER CHARGE
 CARTE BLANCHE Interbank # _____

C.O.D. Enclose \$2.00 deposit per pr.

Acc't # _____ Date Expires _____

Enclosed is _____

NAME _____ (please print)

ADDRESS _____

CITY _____

STATE _____ ZIP _____

How to make a good drink great.



Make any drink with Seagram's 7 and make it a great one. For a smooth, refreshing 7 & Cola, pour 1½ oz. Seagram's 7 over ice in a tall glass. Fill with cola and garnish with lime.

Seagram's 7 Crown
Where quality drinks begin.