

A painting of a winter scene. In the foreground, several birch trees with white bark and black lenticels stand on a snow-covered ground. The trees are bare, with some thin branches reaching out. In the background, a small village with several houses is visible, nestled in a valley. The houses have snow on their roofs. The sky is a pale, hazy blue. The overall style is that of a landscape painting, with visible brushstrokes and a soft, atmospheric quality.

THE
Elks

MAGAZINE
FEBRUARY 1961

"TOTAL DISARMAMENT"

By GARRETT UNDERHILL

VIEW FROM THE COLTS' BENCH

E

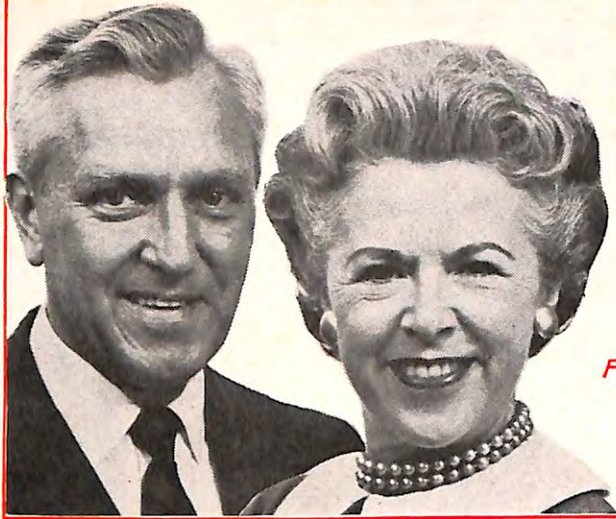

Now! FULL-POWER VITAMINS And MINERALS

Plus **Royal Jelly**

FOR ONLY \$1.00 A MONTH
FOR AS LONG AS YOU WISH

A FULL-POWER MAINTENANCE
DOSAGE CAPSULE TO HELP YOU
FEEL YOUR BEST... ALWAYS

Try Them FREE At Our Expense!

**SEND NO MONEY NOW
PAY ONLY IF SATISFIED**

We invite you to try the DOLLAVIM formula for 30 days — and to pay us only if you are delighted. Discover for yourself the wonderful difference it may make in the way you look and feel — and in the things you can do. Let the proven DOLLAVIM formula help you maintain your strength and energy, ward off fatigue due to vitamin deficiencies — just as it has helped thousands of other men and women in all walks of life!

Dollavim Capsules must work for you or you don't pay a cent for this generous trial supply! Only if they produce all the benefits you hoped for are you asked to pay just \$1.00 (plus a few cents shipping). There cannot be a fairer offer!

IMAGINE! Now for only a dollar a month you can be sure of getting all the vitamins plus minerals nutritional authorities agree are absolutely necessary for well-being! And what's more you may now try this full-power formula without risking a penny!

Without the essential vitamins in sufficient amounts — you cannot hope to feel your best. You gradually begin to feel tired, run-down. You sense a loss of strength and energy, act nervous, depressed. You may even begin to look and feel older than your years... less able to cope with the responsibilities of your home, your family, your job. While these symptoms may arise from other causes, and if they persist, a physician should be consulted — it is a fact that faulty nutrition over a prolonged period can slowly sap your strength and energy, and if neglected, even wreck your health.

HOW DOLLAVIM CAPSULES CAN HELP YOU

That's why the proven, full-power DOLLAVIM formula is invaluable as a food supplement — so important to every otherwise normally healthy man and woman who feels just plain tired and wants a sensible plan to help maintain the pep and energy needed to enjoy life fully — and who wants it at a sensible price!

Every single full-power DOLLAVIM capsule is scientifically compounded to provide you with as many as 20 precious ingredients including all the vitamins known to be essential in human nutrition — PLUS ROYAL JELLY.

Yes, here are all the essential vitamins and minerals in potencies equal to or exceeding the minimum adult daily requirement recommended by the Food and Nutrition Board of the National Research Council.

TRY THE DOLLAR VITAMIN PLAN FOR ONE FULL MONTH

Pay Nothing If The Results Do Not Satisfy You Fully

Why continue feeling tired and run-down... beaten by fatigue and strain? If these symptoms result from an easily corrected vitamin-mineral deficiency, you may make them worse by neglect. You owe it to yourself and your loved ones to see how much better you can feel and act once you start to take DOLLAVIM Capsules.

By enrolling in the Dollar Vitamin Plan now you are never under any obligation! When you have received your first 30-day trial supply, simply take one DOLLAVIM Capsule every day to prove that this formula can help you as it is helping so many others. But you are the judge! If you are not completely satisfied, and do not wish to receive any additional vitamins YOU OWE NOTHING! Simply let us know

in writing before the next month's shipment — or use the handy card provided — and no future shipments will be sent.

But if you are delighted — as so many others are — you don't do a thing! We'll bill you only \$1.00 (plus a few cents shipping) for your first month's supply and see that you get fresh, additional shipments of two months' supplies of DOLLAVIM Capsules every other month automatically and on time — for as long as you wish.

The convenient DOLLAVIM Plan keeps you supplied with DOLLAVIM Capsules at our special di-

WHY OUR LOW PRICE IS POSSIBLE

So many thousands of people participate in this wonderful plan that we have been able to effectuate tremendous savings — from the moment we purchase the basic ingredients to the moment this formula is in your hands.

- We buy ingredients direct in huge quantities from the world's most reliable sources and get the lowest possible prices.
- We produce in quantity under modern sanitary streamlined methods that trim production costs.
- We package automatically in practical plastic containers that keep prices to a minimum for you.
- We ship fresh supplies immediately and have no overstock losses.
- We ship direct to you by the least costly — most dependable distributor—the U.S. Postman.
- We ship regularly every two months and have no "dead season" expenses.
- We keep automatic records on efficient electronic equipment that eliminates costly errors and inaccuracies.

rect-to-you low rate of only \$1.00 (plus a few cents shipping) for each 30-day supply — a saving of many dollars under their retail value.

You take no risk whatsoever — you may drop out of this Plan any time you wish without spending an extra penny by just notifying us of your decision a few days before your next bi-monthly shipment. Take advantage of our generous offer. Mail the postcard now!

DOLLAR VITAMIN PLAN, INC.,
1861 Broadway, New York 23, N. Y.
IN CANADA: 485 Perth Ave., Toronto 9, Ont.

© 1960 THE DOLLAR VITAMIN PLAN, INC.

® "DOLLAVIM" REG. T. M.

EACH DAILY DOLLAVIM CAPSULE FOR MEN CONTAINS:

Vitamin A	5,000 USP Units	Calcium	
Vitamin B1	1.6 mg.	Pantothenate	1 mg.
Vitamin B2	1.3 mg.	Folic Acid	0.1 mg.
Vitamin B6	0.1 mg.	Calcium	37 mg.
Vitamin B12	1 mcg.	Phosphorus	30 mg.
Vitamin C	35 mg.	Iron	15 mg.
Vit. D	450 USP Units	Copper	0.5 mg.
Royal Jelly	1500 mcg.	Manganese	0.1 mg.
Niacinamide	14 mg.	Sulfur	8 mg.
		Zinc	0.1 mg.
		Magnesium	1 mg.

Under the plan for women, dosages are slightly changed and Vitamins E, K and desiccated liver are added. Check "Women's plan" box in post-card if desired.

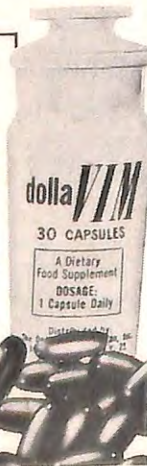

HOW TO GET WHAT YOU WANT BY USING THE POWER OF YOUR "INNER MIND"

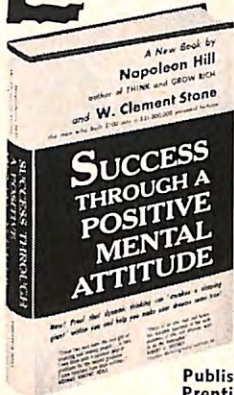

Published by
Prentice-Hall

PROVED WORKABLE BY ACTUAL EXPERIENCE ...

"Those of us who read and follow this dynamic approach to the daily problems of life, will discover ways to do the impossible!"

—Robert A. Whitney,
President, Marketing Audits
Institute, Inc.

"The contents of this wonderful book should be 'must' reading in every high school and college throughout the length and breadth of this land."

—E. V. Rickenbacker, Chairman
of the Board, Eastern Air Lines

"There is an old French proverb, 'Be very careful what you set your heart on, for you will surely achieve it.' This volume not only gives guidance as to WHAT to set one's heart on—but it tells HOW to achieve it!"

—Dudley Dowell, Executive Vice-
Pres., New York Life Ins. Co.

"This book, presented in such a precise, candid and simple manner, should prove a great inspiration to the people privileged to read it, and should help them to hurdle the daily problems of life."

—W. P. Lawless
Reynolds Metals Co.

"You have made a lasting contribution to humanity through this work. Many books tell you of things one can do, but seldom tell how to do them. In your book you do both—and, in a simple, easy-to-understand manner."

—Ben Sweetland
Hillsborough, Calif.

"It is one of the most inspirational and motivating books I have ever read."

—Peggy M. Gardner
Raleigh, N. C.

"It will contribute to general happiness, which comes from successful accomplishment by individuals with the right mental attitude."

—Arthur H. Motley
President, Parade Publications

"These two men have the rare gift of inspiring and helping people . . . In fact, I owe them both a personal debt of gratitude for the helpful guidance I have received from their writings." —Norman Vincent Peale

SUCCESS THROUGH A POSITIVE MENTAL ATTITUDE

by NAPOLEON HILL, author of "Think and Grow Rich" and
W. CLEMENT STONE, the man who built \$100 into a \$35,000,000 personal fortune.

This amazing new book will show you how to *awaken and release the forces inside you and get what you want*. This is no "head-in-the-clouds" theory. It is as down to earth as the job you want to get, the house you hope to own, the person you want to marry. "SUCCESS THROUGH A POSITIVE MENTAL ATTITUDE" shows you how to turn your desires into REALITIES . . . how to *make your subconscious work for you* to help you overcome obstacles and accomplish whatever you set your mind to do.

If you want bigger earnings—a better job—more money in the bank—improved health—the love and admiration of others—glowing well-being and spiritual serenity . . . YOU CAN TEACH YOURSELF TO ATTRACT THESE BENEFITS INTO YOUR LIFE.

Every thought you think has either a POSITIVE or a NEGATIVE mental charge and can either

ATTRACT or REPEL the good things in life!

But don't expect to get what you want just by "wishing" for it. You must direct both your thoughts AND your actions into *specific* channels which *you* must decide upon—and which *you* must discipline yourself to follow, step-by-step, as directed in this great book. It will show you:

- How to make up your mind when you're undecided what to do.
- How to create a mental image of the thing you want . . . then believe in it so firmly that it actually happens.
- How to avoid doing the 2 things that repel wealth.
- How to make your brain a receiving set for ideas that will advance you toward your goal.
- How to train yourself to see "what can be," not just what is.
- How to raise your energy level.
- How to acquire wealth by using "other people's" money.
- How to develop "inspirational dissatisfaction" to convert a failure of one day into success on another.
- How to use "self-suggestion" to rearrange your present pattern of living and shape it into a new, more successful pattern.
- How to get others to respect your judgment and look to you for leadership.
- 6 steps to follow in finding the answer to any problem.
- 6 ways to win friends by what you DO and SAY.
- 17 bed-rock principles of success, and how to apply them.
- How to keep your mind ON the things you do want and OFF the things you don't want.
- How to make use of your subconscious mind to solve your problems, overcome obstacles, get new ideas, win advancement or financial gain.

This book proves to you that "what the mind can conceive and believe—the mind can achieve." It tells you precisely how to set your sights on a definite goal and attain it, through persistent thinking and positive action. It gives

you clearcut directions on how to focus into full concentration the unfailing power of a POSITIVE MENTAL ATTITUDE to bring you anything in life you really want!

SEE RESULTS IN 10 DAYS This Extraordinary Book Sent for 10 Days' FREE TRIAL

Why not see for yourself how "SUCCESS THROUGH A POSITIVE MENTAL ATTITUDE" can help you attain the things you want and become the person you aspire to be? Use it for 10 days free. Try out some of the procedures it gives you. Then, if you decide to keep it, pay only \$4.95, plus a few cents for postage and shipping. Otherwise, just send it back and owe nothing. Mail the coupon now for your free-trial copy.

MAIL THIS COUPON

Combined Registry Company, Dept. EM-261
5050 Broadway, Chicago 40, Ill.

WITHOUT OBLIGATION, please send me for 10 DAYS' FREE TRIAL, a copy of "SUCCESS THROUGH A POSITIVE MENTAL ATTITUDE" by Napoleon Hill and W. Clement Stone. In ten days I will either remit \$4.95 plus postage or return the book and owe nothing.

NAME _____

ADDRESS _____

CITY _____

ZONE _____

STATE _____

HOW TO SAVE POSTAGE: Send \$4.95 with this coupon and we will pay delivery charges. Same 10-day return privilege; your money back if not satisfied.

THE LUCKIEST \$7 I EVER SPENT

By a Wall Street Journal
Subscriber

Not long ago I picked up my first copy of The Wall Street Journal. I expected dull reading. Imagine my surprise when I found some of the best articles I'd ever read!

I sent for a Trial Subscription. For the first time in my life I began to understand why some men get ahead while others stay behind. I read about new inventions, new industries and new ways of increasing my income. Also I got ideas on what to do to reduce living expenses and taxes. My Trial Subscription to The Journal cost me \$7. It was the luckiest \$7 I ever spent. It has put me hundreds of dollars ahead already.

This story is typical. The Journal is a wonderful aid to men making \$7,500 to \$25,000 a year. To assure speedy delivery to you anywhere in the U.S., The Journal is printed daily in seven cities from coast to coast.

The Wall Street Journal has the largest staff of writers on business and finance. It costs \$24 a year, but in order to acquaint you with The Journal, we make this offer: You can get a Trial Subscription for 3 months for \$7. Just send this ad with check for \$7. Or tell us to bill you. Address: The Wall Street Journal, 44 Broad St., New York 4, N. Y.

EM-2

INCREASE

Your Income up to

50%

INVEST IN

Launderamas

Coin-Operated • Fully Automatic • Laundry Stores

Launderamas are the perfect "second" business for men in all salary brackets. The initial Launderama investment is amazingly low; the return is exceptionally high and begins the day the store opens.

Because Launderama operating costs are extremely low and free of franchise fees, you are able to offer your customer from 40% to 60% savings on all their laundry needs. Consequently, Launderamas quickly win community acceptance and popularity and are conducive to chain operation.

You enjoy built-in security when you invest in Launderamas because they are competition proof. Their custom-designed equipment can handle twice the amount of clothes as the average commercial washers and at half the maintenance and utility costs. And this outstanding double-load (20 lb.) equipment is available to you at the lowest financing terms in the industry—10% down with the balance financed at 6% over three years.

The nation-wide Zeolux Corp. organization, pioneer in this highly successful and proven field, is ready to offer you assistance in planning, establishing and financing your own laundry store business.

For complete information and name of nearest distributor call:

ZEOLUX CORP.

Dept. EK,
261 MADISON AVENUE
NEW YORK 16, NEW YORK

YUkon 6-9740

© 1960 Zeolux Corp.

THE ELKS MAGAZINE

VOL. 39 NO. 9

FEBRUARY 1961

NATIONAL PUBLICATION OF THE BENEVOLENT AND PROTECTIVE ORDER OF ELKS OF THE UNITED STATES OF AMERICA, PUBLISHED UNDER THE DIRECTION OF THE GRAND LODGE BY THE NATIONAL MEMORIAL AND PUBLICATION COMMISSION.

THE ELKS NATIONAL MEMORIAL AND PUBLICATION COMMISSION

JOHN S. McCLELLAND
Chairman

EMMETT T. ANDERSON
Vice-Chairman

JAMES T. HALLINAN
Treasurer

WADE H. KEPNER
Secretary

EARL E. JAMES
Assistant Secretary and Assistant Treasurer

JAMES R. NICHOLSON
General Manager

LEE C. HICKEY
Editor

REGINA M. FISHER
Associate Editor

WILLIAM O. CHESSMAN
Art Director

ROBERT ELMAN
Associate Editor

GENEVIEVE G. CONOVER
Advertising Production

WILLIAM H. MAGRATH
Controller

JOHN SCHMITT
Circulation Manager

THEODORE I. SCARR
Promotion Manager

EDITORIAL OFFICES, 386 Park Avenue South, New York 16, N. Y.

Cover Painting.....	DONALD F. MOSS	
Tom Wrigley Writes from Washington.....		6
Membership and Strong Lodges—A Message from the Grand Exalted Ruler.....		8
Elks National Foundation—"The Joy of Giving".....		10
"Total Disarmament".....	GARRETT UNDERHILL	12
Battle Report from the Colts' Bench.....	AL STUMP	14
For Elks Who Travel.....	HORACE SUTTON	16
Rod and Gun.....	DAN HOLLAND	18
Lodge Visits of John E. Fenton.....		19
Elks Family Shopper.....		22
Guardians of Freedom: the Elks and the Press.....		28
Travelguide.....		30
Letters from Our Readers.....		35
News of the Lodges.....		36
Play Cards with John R. Crawford.....		44
In the Dog House.....	ED FAUST	46
Elks National Service Commission.....		50
The Best Trade I Ever Made.....	GEORGE WEISS	59
Freedom's Facts.....		60
Elks Home Workshop Tips.....	HARRY WALTON	61
THE ELKS MAGAZINE Editorials.....		62



ADVERTISING OFFICES



CHICAGO 1
360 North Michigan Avenue
STATE 2-6662

NEW YORK 16
386 Park Avenue South
MURRAY HILL 4-5495

LOS ANGELES 36
5909 West 3rd Street
WEBSTER 1-1371

SAN FRANCISCO 8
333 Kearny Street
EXBROOK 2-4073

PORTLAND 25, ORE.
2685 S.W. 89th Avenue
CYPRESS 2-3858

POSTMASTER: Send notices concerning addresses to:
THE ELKS MAGAZINE, 386 Park Avenue South, New York 16, N. Y.

Members are asked, in changing address, to send this information: (1) Name; (2) Lodge number; (3) Membership number; (4) New address; (5) Old address. Please allow 30 days for a change of address to be effected. THE ELKS MAGAZINE, Volume 39, No. 9, February, 1961. Published monthly at McCall Street, Dayton, Ohio, by the Benevolent and Protective Order of Elks of the United States of America. Second class postage paid at Dayton, Ohio, and at New York, N. Y. Acceptance for mailing at special rate of postage provided for in Section 1103, Act of October 3, 1917, authorized May 20, 1922. Printed in Dayton, Ohio, U.S.A. Single copy price, 20 cents. Subscription postage, add 50 cents a year; for foreign postage, add \$1.00 a year. Subscriptions are payable in advance. Manuscripts must be typewritten and accompanied by sufficient postage for their return via first class mail. They will be handled with care but this magazine assumes no responsibility for their safety.

Copyright, 1961, by the Benevolent and Protective Order of Elks of the United States of America

LETTER-PERFECT



FOR OFFICE *Olympia Standard Office Typewriter* ...preferred by "perfectionists" the world over! Fully-equipped with a score of unique features for easier, faster, finer typing. Automatic paper injector-ejector—interchangeable carriage—spring-cushioned

speed keys—correcting space bar—to name just a few. All at no extra cost. Precision-built in Europe's largest, most modern typewriter factory. Put one to the test—"on-the-job"—before you decide on any other typewriter. See Yellow Pages for nearest dealer.



HOME—SCHOOL *Olympia DeLuxe Portable* ... makes "short work" of the whole family's assignments! A breeze to operate—even for the inexperienced typist. Fully-equipped with the finest features—from convenient half-spacing to key-set tabs. Handsome color options. Choice of type styles.



OR TRAVEL *Olympia Lightweight Portable* ... for anyone who's going places! Slim, trim and compact—weighs less than 10 pounds—case and all. Unexcelled for precision-built quality—it's the fastest, smoothest, most efficient lightweight portable you can buy. Distinctive carrying case.

FREE—Type Style Selector Guide for *Olympia DeLuxe Portables*—write to Olympia Div., Dept. EC, Inter-Continental Trading Corp., 90 West St., N.Y.C. 6.

Olympia

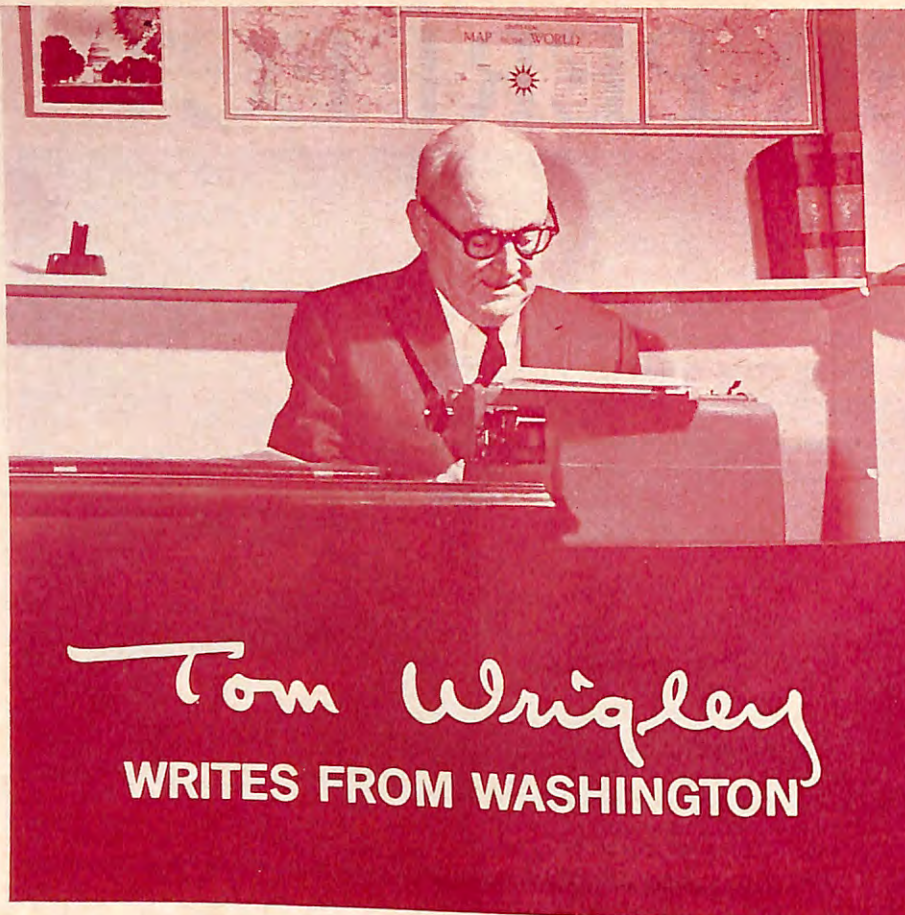

Tom Wrigley WRITES FROM WASHINGTON

NOW COMES THE TEST of the new administration's program. The whoop-la and the tumult of the Inauguration of John Fitzgerald Kennedy as President of the United States is dying away. It's government as usual, with new heads of state buckling down to meet the pressing challenge of critical domestic and foreign problems. Lights burn late in the Executive Offices of the President. Newsmen and photographers work feverishly to keep up with headline developments. Press service tickers clatter day and night, constantly watched by crowds of reporters. Congress grinds away. Government departments function without noticeable change. There is no confusion. Here, in the greatest country on earth, with the highest living standards, changeover in administration takes place with no disorder, no lost motion. It is the American system, and under it thousands of government employees, plus thousands of elected and appointed citizens, go about their jobs as loyal workers.

NEW PRESIDENTIAL RETREAT will be turned over to the President and Mrs. Kennedy February 1. It's all ready for them, spic and span, a stately big house near Middleburg, Va., called Glen Ora, on a 400-acre estate in the midst of the famed hunt country. The Kennedys leased it from Mrs. Raymond Tartiere of Washington at a rental said to be \$600 a month. It has everything, a large swimming pool, six bedrooms and five baths, two horse

barns housing a half-dozen saddle horses each. The estate will have a particular charm for Mrs. Kennedy, who is an expert horsewoman. Secret Service Agents assigned to guard the First Lady are already learning how to ride to hounds. Yoicks!

AIR FORCE personnel cut to save \$8-million a year may ground over 1,600 officers in 1961. All officers so grounded will continue to draw full flight pay but the savings will be in fuel and plane maintenance. Last year's ceiling of 99,046 pilots is now considered more than needed.

GUARDING THE PRESIDENT will be no easy job for the U. S. Secret Service. President Kennedy, full of vim and vigor, wants to get around and go places. A 20-hour day is no strain. In addition, the Secret Service will deal with the usual threatening letters from cranks and sometimes from dangerous persons. All such communications are channelled into "Room 98" in the Executive Offices adjoining the White House. Here, in a four-room laboratory, S. S. Agents examine all suspicious mail and packages. The place is full of complicated machines and elaborate files. A new file—"John Fitzgerald Kennedy"—has been set up and already contains some crazy letters. About 90 per cent are from harmless crackpots. All such mail is checked against a filing system of two million cards. There are 24 tests, but one of the biggest aids in

matching correspondence is in the words "Washington, D. C.," which have to be written on every envelope.

REDEVELOPMENTS cost money, as scores of cities throughout the country are now finding out. Washington has a huge project in the Southwest section which will cost \$70-million, of which the District will pay \$25-million. This seems exorbitant, but a survey brought out something new. Real estate values alone throughout the area will increase six-fold and property taxes will rise from \$31,000 to more than \$400,000 annually when the job is finished. Further revenues will be created by new businesses.

PRESS SECRETARY for "Jackie" is a necessity because of the questions that pour into the White House concerning the Kennedys' baby, John, Jr. Miss Letitia K. Baldrige of Omaha, Mrs. Kennedy's social secretary, has been handling the stream of news detailing the First Lady's activities, and has been swamped with queries about the White House nursery.

AN OKAY for contact lenses was given before the clinical meeting of the American Medical Association. Some 10,000 doctors heard Dr. John W. McTigue, noted Washington ophthalmologist, declare that such lenses properly fitted are a valuable optical and medical aid, safe to wear. Over three million people now wear them all day long and another three million use contact lenses part time for social functions, public appearances, etc. Ill-fitted lenses, he said, "wind up in a drawer."

CHIEF ATTRACTION in the Capital right now is the White House, where even in this wintry weather long lines of visitors wait each day to go through the Executive Mansion. The Washington Monument is in second place.

DISTRICT DABS . . . Military top brass believes any war in the future will be a "short" one, not lasting more than one year . . . If Congress follows all Democratic platform recommendations nine new Federal agencies may be set up, creating thousands of new patronage jobs . . . Supreme Court Justice William O. Douglas predicts Red China will be the third largest industrial power by 1967, the U. S. and Russia being first and second . . . Up to now, the Congo muddle has cost the U. S. at least \$26-million, while Russia pays nothing . . . If a rocket wrecks your house, the most the Government will pay is \$5,000 . . . A retired couple here needs \$3,047 a year for living expenses, the Bureau of Labor Statistics reports . . . Over 1,500 persons in Washington are looking very proud these days because they all go by the name of KENNEDY. ● ●

On U.S. Route 66 — Only 39 Miles from America's 7th Fastest Growing City

ALBUQUERQUE, NEW MEXICO . . .

An Acre of Your Own in

THE VALLEY OF THE ESTANCIA RANCHETTES

MEMBER ALBUQUERQUE
CHAMBER OF COMMERCE

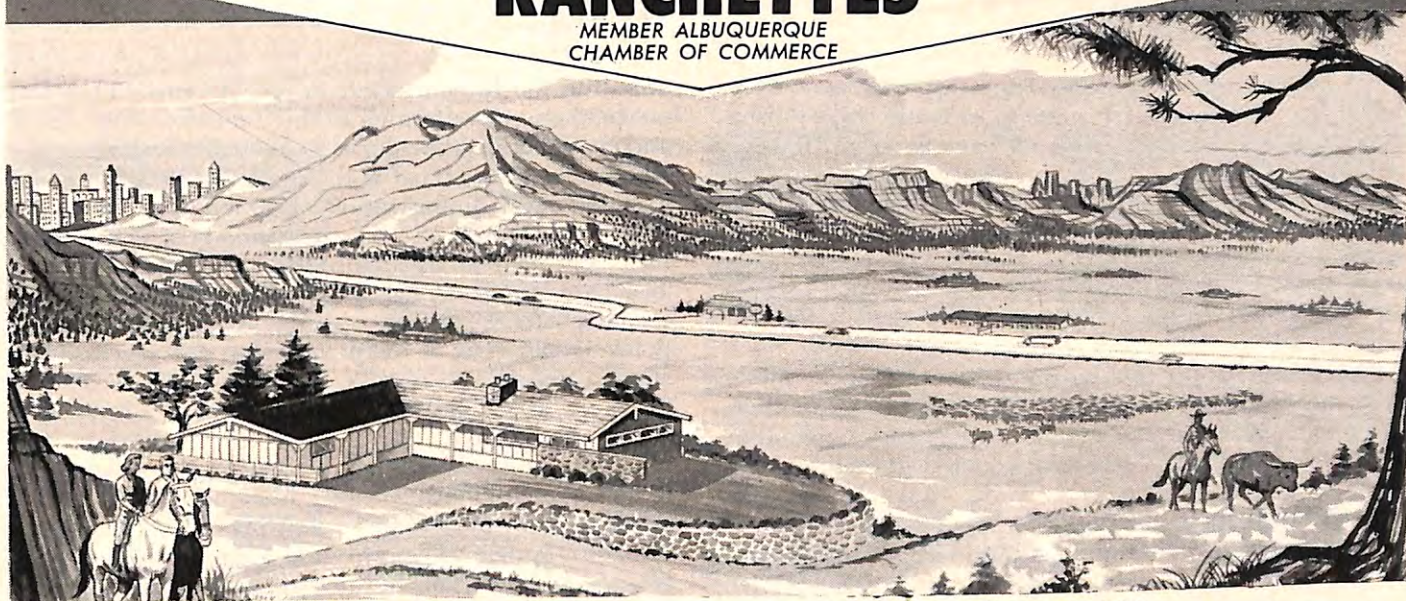

FULL ACRE
FULL PRICE **\$395**

ONLY **\$10** DOWN
A MONTH

Suddenly — almost without warning — the land boom is on in New Mexico. All at once Americans have discovered the "Land of Enchantment" . . . and homes and ranchettes are springing up on lush verdant tracts which until now were enormous ranches.

And especially is this true of the lovely valleys surrounding Albuquerque, the queen of New Mexico. This exciting city is bursting at the seams and homes are spilling out in all directions. Albuquerque has become America's "7th fastest growing city" — and is picking up speed at an astounding tempo.

Astounding? Please consider: In 1940 Albuquerque had less than 36,000 people. By 1950 it had soared to 97,000. And in the last 10 years it has rocketed to more than 260,000!

There are so many reasons for this fantastic rate of growth. Nowhere in America is there land more beautiful than the rich valleys that rim Albuquerque. The climate is possibly without equal in all of America — a summertime of balmy sunny days* and bracing nights — blanket-sleeping nights; and in the winter equally sunny days* — shirt-sleeve weather. Health? This is a region whose mildness and purity of climate have given new life to people from all parts of our land — where, in respiratory ailments alone, thousands of cures have been miraculously achieved by the mild weather, the dry air, the abundant sunshine, the low humidity. In the words of the Encyclopedia Britannica the Albuquerque region is "a health resort"! And what about sports, entertainment, activities, opportunity? In the lofty close-by mountains are fishing, swimming, hunting. Skiers wear shorts. Golf is played the year 'round. Albuquerque itself is crammed with magnificent shops, theatres, churches, schools — including the University of New Mexico with 7000 enrolled students, bright new college buildings and modern football stadium. Albuquerque has the 5th busiest airport in the United States. Its industry and employment potential are boundless. Its 3 television channels and 9 radio stations, its opportunities in land ownership, jobs, small business; its sunniness, its freshness and sparkle — all of these mark the personality of a great city.

The wonder is not that Albuquerque is growing so rapidly. The wonder is that one can still buy a lovely piece of land close to the city at so low a price as \$395 an acre! All you have to do is to take a look at the six cities which in all of America have grown even faster than Albuquerque. What would you have to pay for an acre of comparable land only 39 miles from their shops and theaters?

(THESE FIGURES INCLUDE OUTSIDE CENTRAL CITY)

	Population	Rate of Rise 1950-1960	Cost Per Acre of Comparable Land 39 Miles from Downtown
1. San Jose, Calif.	639,615	120.1%	\$2,500 — \$ 5,000
2. Phoenix, Arizona	652,032	96.5	\$3,500 — \$ 7,000
3. Tucson, Arizona	262,139	85.6	\$1,500 — \$ 3,000
4. Miami, Florida	917,851	85.4	\$5,000 — \$10,000
5. Sacramento, Cal.	500,719	80.7	\$2,000
6. San Diego, Cal.	1,003,522	80.2	\$4,000 — \$ 8,000
7. Albuquerque, N. M.	260,318	78.7	\$395 (Valley of The Estancia Ranchettes)

These statistics are eye-openers, aren't they? Yet real estate men are saying that the prices you have just read will soon apply to the Albuquerque region!

And as lovely and luxuriant an area as Albuquerque can boast is The Valley of the Estancia Ranchettes. Rimmed by mountains, lying flush alongside the most important highway in the West, Route 66, and only 39 miles from Albuquerque, The Valley of the Estancia Ranchettes is the essence of the enchanting Southwest. Please read this carefully! The Valley of the Estancia Ranchettes are not barren desert tracts. They are lush and green! Water waits to be tapped. The soil is so fertile as to bear fruit trees and truck gardens. Our Route 66 neighbors frame the landscape with their low modern ranchettes, homes, motels. Our next door neighbor is the famed \$200,000 Longhorn Museum of the Old West . . . Oh yes, this is a very lovely land.

As our headline says, an acre in our beautiful VALLEY OF THE ESTANCIA RANCHETTES costs \$395 complete! And the terms are \$10 down and \$10 a month per acre. That's it — no extras, no hidden additional costs. You may reserve as many acres as you wish. AND YOU TAKE NO RISK IN SENDING YOUR \$10 TO RESERVE YOUR ONE ACRE RANCHETTE SITE. Your \$10 reserves an acre for you, but you have the unqualified right to change your mind. As soon as we receive your reservation we will send you your Purchase Agreement and Property Owner's Kit. The package will show you exactly where your property is and will include full maps, photographs and complete information about your property. Other maps will show you nearby Arizona — even old Mexico itself, 250 miles away. You may have a full 30 day period to go through this fascinating portfolio, check our references, talk it over with your family. If during that time you should wish to change your mind (and you don't have to give a reason either) your reservation deposit will be instantly refunded. (ALBUQUERQUE BANK REFERENCES).

Experienced realtors think that the Albuquerque area presents the most exciting acreage buy in America. On the outskirts of the city, land is now going for \$5000 to \$6000 an acre. One day soon the Valley of the Estancia Ranchettes could be a suburb of Albuquerque. Act now. You'll be forever grateful that you did.

VALLEY OF THE ESTANCIA RANCHETTES Dept. L-21

503 SAN MATEO N.E., ALBUQUERQUE, NEW MEXICO

Gentlemen: I wish to reserve _____ acres in the VALLEY OF THE ESTANCIA RANCHETTES. I enclose a deposit of \$_____. (Please send deposit of \$10 for each \$395 acre you reserve.) Please rush complete details, including my Purchaser's Agreement, Property Owner's Kit, maps, photographs, and all data. It is strictly understood that I may change my mind within 30 days for any reason and that my deposit will be fully and instantly refunded if I do.

Name _____
Address _____
City _____ Zone _____ State _____

* Last year for example, there were only 8 days that were not sunny.

THIS OFFER NOT INTENDED FOR RESIDENTS OF NEW YORK STATE



Membership and Strong Lodges

Elkdom is truly a wonderful fraternity. Just how wonderful has been revealed to me in so many ways during these past seven months when I have been paying official visits to lodges, State Association meetings and District gatherings. I have always been proud that I was an Elk, but my Elk membership has taken on a richer meaning, a deeper significance, as it has been my opportunity and privilege to get a closer, personal acquaintance with my Brothers in all parts of our broad and varied land.

I have been impressed by the differences in the mode of living from one section of the country to another, differences dictated by climate, topography and other physical conditions. These are reflected in architecture, in social customs and in other ways. But what has impressed me most is not the differences but those things that we all have in common, the ideas and ideals that we share and which serve to unite us into a great nation. Among these forces that unite us, there is none stronger and more formidable than Elkdom.

Wherever you go, in every section of the country, there are the Elks with their spirit of hospitable good fellowship, their reverent devotion to God, their stirring and inspiring patriotism. North or South, East or West, the Elks proudly parade the Boy Scout Troops under their sponsorship. With enthusiasm they devote long hours and contribute large sums of money to community youth projects and programs. If the local hospital needs a baby incubator, the Elks get it. Pooling their resources of men and money, they sponsor statewide programs battling against cerebral palsy and cancer, and provide the best hospitals for the care and relief of crippled children. Everywhere, all the year around, the Elks see that hospitalized veterans have entertainment and recreation that reminds them that they are not and never will be forgotten.

To carry on these wonderful programs, Elkdom must be strong, which means that our subordinate lodges must be strong. And to be strong, a lodge must give proper attention to such fundamentals as membership. New men, men who share our ideals, men who count in the community, and especially young men must be brought into a lodge every year in numbers sufficient to offset normal losses and to show a gain if that lodge is not going to slip backward and ultimately become a weak lodge.

The fact is that too many of our lodges have been

initiating too few members in recent years. They have not paid enough attention to the "housekeeping" details, and as a result they have gone backward instead of making progress. That is the reason why, at the beginning of my administration, I asked every lodge to initiate, by March 31, 1961, new members at least equal to 10 per cent of its membership as of last March 31. That is more than most lodges initiated last year or in recent years. On the average, however, if a lodge initiates 10 per cent of its membership every year, it will show a net gain in membership each year. That is the direction in which every lodge's membership program should be moving.

Membership should not be left to the officers of a lodge or a few hard-working Elks. It is a program in which every member can and should participate. I therefore appeal to you to help your lodge by inviting your neighbor, your business associate and above all your son, to become your Brother in Elkdom, and I urge that you extend the invitations promptly so that they can become members before March 31.

There are other matters of lodge management that should have our careful attention during these next two months. One of them is lapsation. From now until March 31, the Lapsation Committee, assisted by the officers, should work hard and through personal contact be sure that every delinquent member is paid up and in good standing. Here again is an opportunity for a good Elk to assist his lodge by checking the list of delinquents and getting in touch with those whom he knows. A word from a friend is most persuasive.

During these remaining months of the lodge year, let us also pay special attention to the Stray Elks in our community. Our Stray Elk Program initiated three years ago has amply demonstrated that we can reduce lapsation materially by giving Stray Elks a genuine welcome to our lodges and activities. This program should be carried on all year for maximum effectiveness, but let us make sure that we bring in all of the Stray Elks during the next two months.

A healthy membership growth, decreased lapsation, and a successful Stray Elk program are vital factors in sound lodge management. They cannot be neglected. I hope that every member of the Order will co-operate with his lodge officers to insure that every lodge is on a sound membership basis when the books close on March 31, 1961.

A handwritten signature in cursive script that reads "John E. Fenton".

John E. Fenton, *Grand Exalted Ruler*



WINDSHIELD DE-ICER... Removes every trace of ice, frost, sleet in 60 seconds! Just spray—windshield problems go away! No scraping—no frozen fingers! Provides clear windows for safe driving. Prevents re-icing; airlines use it! Windshields sprayed before a freeze protected up to 3 days. 9 oz. spray can.....**98¢** ea. 3 for**\$2.79**

VENUS FLYTRAP EATS LIVE FLIES

Exquisite house plants catch and eat live insects! Bear white flowers. Green leaves form rosettes. Each leaf tipped with pink trap. Insect, lured by color & nectar, enters. Trap snaps shut, absorbs him. Also eats raw beef or feeds thru roots. Easy-to-grow bulbs develop in 3-4 weeks. 3 Bulbs.....**\$1.00** 18 Bulbs.....**\$5.00**



KEEP CAR WINDOWS CLEAR OVERNIGHT—IN FREEZING WEATHER!

Cover up with Auto Cap—find windshield and windows clear in the morning despite snow, sleet, freezing rain, frost! Perfect protection! Insures good visibility in sub-zero cold. Eliminates one of the big nuisances of winter driving. Heavy polyethylene plastic. Won't freeze in winter's worst. Covers top and all

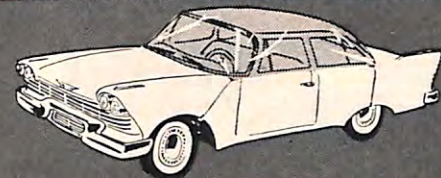

windows. Fastens to fender; is held firmly in place by 4 elastic shock cords with attached rubberized hooks. Goes on in seconds—off in a flash for driving. No more sweeping or scraping! Folds for storage. Fine as utility cover, too. Passenger Auto Cap or Station Wagon Cap (give choice). Ea. **\$5.98** 2 for **\$11.50**



GIANT DESK CALENDAR... Keeps the whole month's appointments, memos always in view! At a glance, know your schedule for 30 days. Ends embarrassing mistakes and forgetfulness. 12 months, in gold-stamped personalized plastic leather case. 11 1/4" x 9". Black or Old Ivory. State name and color. Each.....**\$1.00** 6 for.....**\$5.00**



LIQUID 24 KARAT GOLD... Now you can transform unsightly metals into shimmering golden treasures! They'll never tarnish or need polishing. Liquid Gold plates copper, brass, bronze, steel, tin, iron, nickel, etc. Easy to use. Requires no special equipment, electricity or skill. Supply sent will plate 100 sq. in. Each.....**\$1.00** 6 for.....**\$5.00**



ELECTRIC CIGARETTE LIGHTER... No wick, no lighter fuel needed! A quick flick of the switch & secret panel opens to provide instant light for cigarette, despite wind or weather! Feather-light engraved metal case, with built-in flashlight. Uses 2 pen light batteries obtainable anywhere. Each**79¢** 2 for**\$1.50**

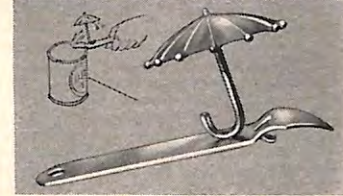

NO-SPRAY BEER CAN OPENER!... Here's to no more beer in your eye! New "spray protected" opener has its own small umbrella to guard you against sudden updrafts! Keeps you and the ceiling from getting squirted. Golden-toned metal, regular size, with matching umbrella. Fun, useful in the home bar. Each.....**\$1.00** 3 for.....**\$2.79**



LIFETIME SOCIAL SECURITY CARD... Indestructible—cannot be harmed by fire, water, oils, etc.! Wafer thin, two-tone solid aluminum—a wallet sized 3 1/2" x 2"—engraved with social security number and full name. Positive, permanent identification to keep with you at all times. Specify number and name. Each**\$1.00** 3 for**\$2.79**



KEEPS FOG & MIST AWAY... Avoid accidents due to poor windshield vision! One wipe with new No-Fog Safety Mitt—windows can't fog or mist for weeks. Leaves steamed bathroom mirrors sparkling! Added feature: Glow-in-the-dark binding. Slip it on bumper for emergency roadside stops. Each.....**\$1.00** 3 for.....**\$2.79**



6 ENCHANTING LAMPS... glow in the dark, without electricity! Self-illuminating! A wonderful way to cut down your electric bill. Cute lantern styling, of unbreakable plastic. Gathers light by day... radiates it at night. Use to indicate cellars, stairways, as lamp and shade pulls. 2" high, in assorted colors. Set of 6.....**\$1.00** 3 sets.....**\$2.79**



KEEP CANCELLED CHECKS SAFE... Roomy check bank could save you money! Holds 800 cancelled checks. Keeps them safe—ready at a moment's notice if needed for tax purposes or proof of payment. Green ripple-tone box with golden stamp; tab index dividers for 5 year file. 7 1/4" x 4 3/4" x 3 1/4". Each.....**\$1.00** 3 sets.....**\$2.79**



MAGIC FOOT WARMER... Even in sub-zero weather this comfortable cushion keeps your feet WARM! Just scissor dotted pattern to fit foot; insert in shoe. Gives glowing warmth on body contact. Amazing action never wears out! Proven performance by the military. Regular (fits size 7-13).....**\$1.25** Junior (size 10-6).....**\$1.00**



NOW COMPUTE RACE RESULTS FAST—ELECTRONICALLY! Racing fans! Here's a remarkable new pocket-size electronic "brain" that does all your handicapping for you! It automatically computes race results... predicts probable winners electronically from past performance data you feed into it. Unbelievably easy to use! You'll be amazed and delighted! Just press a

button and results are indicated instantly by flashing light on face of machine. Durable high-impact plastic; compact, lightweight, easily carried anywhere! Comes complete with battery, instructions and special "Handicapper's Guidebook". Great for turf enthusiasts, sportsmen, home analysts. Order today! **\$14.95**

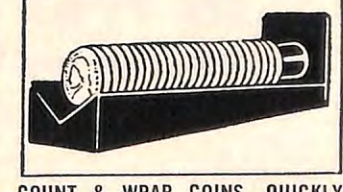

COUNT & WRAP COINS, QUICKLY! Do it automatically, in half the time with Coin Counter! No fuss or fumbling! Just slip coins into plastic tray up to indicator line, and slide wrapper under coins. No mistakes! You can even wrap easily with plain paper. Counts pennies, nickels, dimes, quarters. Each.....**89¢** 6 for.....**\$5.00**



PERFORM CARD MYSTERIES with Wonder Deck! This dubious 52 makes it simple. Each card is MARKED. You, and only you, can easily read each one from the back. Markings are undetectable to the uninstructed. Bridge size, linen finish, with instructions for thrilling tricks. For fun and "magic" only, of course. Deck.....**\$1.49** 2 for.....**\$2.79**



SNUG KNEE WARMERS... Recommended for quick, soothing relief to sufferers of arthritis, bad circulation, foot, ankle ailments! Promotes circulation! Of 100% zephyr virgin wool with STRETCH construction—assures snug, comfortable fit for men and women. Regular Size (for average people). Pair.....**\$1.98** Extra Size (larger). Pair.....**\$2.50**

Mail to **SPENCER GIFTS** Today

SPENCER GIFTS, AF-37 Spencer Bldg., Atlantic City, N. J.

My Name Is _____ PLEASE PRINT

Address _____

City _____ Zone _____ State _____

HOW MANY	NAME OF ITEM	PRICE

SORRY, NO C.O.D.'s All orders sent Postage Paid.

(Enclose a check or money order with your order) **TOTAL ENCLOSED**

Satisfaction Guaranteed or Money Refunded Except Personalized Items

How the Buzz of a Dying Bee



Created a Great New Thrill for Fishermen!

We learned from a barefoot boy while fishing the Ouachita River. After a full day fishing, we were empty handed. The boy had 30 whoppers on a stringer—all attracted to his bait by a buzzing bee sealed in a mason jar under the water. Now I have had the identical sound scientifically reproduced in a compact, waterproof, battery operated buzzer. My fish caller will bring the big ones racing to it. They can't resist it. Then, using your own tackle, drop your bait alongside my fish caller and you've got a savage bite from any kind of insect feeding or bottom feeding fish. You get the big ones because they scare away the little fellows. But don't buy anything now. Instead, let me mail you—free and postage prepaid—actual underwater photos and testimonials. I'll also tell you how you can test the magic of my fish caller in your own waters six full months at my risk on a money-back guarantee. Just send your name to me on the coupon or postcard Address Frank Birch, 335 West Madison St., Chicago 6, Illinois. Room 202.

Frank Birch, Room 202
335 W. Madison St., Chicago 6, Illinois
Please rush free information on your fish caller and your six months trial guarantee.

Name.....
Address.....
City..... State.....

Let Barron's Help You PICK GOOD INVESTMENTS IN 1961

17 weeks' trial only \$5

To help you build your capital and increase your investment income—get a trial subscription to Barron's National Business and Financial Weekly. It will give you the facts you need to make yourself a better judge of the investment values in today's markets.

No other business or investment publication is like Barron's. It is written for the man who makes up his own mind about his own money. It is the only weekly affiliated with Dow Jones, and has full use of Dow Jones' vast, specialized information in serving you.

In Barron's you are shown *what, where, and why* the REAL VALUES are, behind current security prices. You get clear, well-founded information each week . . . on the condition and prospects (the changing fortunes) of individual corporations—and on industrial and market trends.

A trial subscription—17 weeks for only \$5—brings you:

Everything you need to know to help you handle your business and investment affairs with greater understanding and foresight . . . the *investment implications* of current political and economic events . . . the *perspective* you must have to anticipate trends and grasp profitable investment opportunities.

See for yourself how important Barron's can be to you in the eventful weeks ahead. Its subscription price is \$15 a year, but you can try it for 17 weeks for \$5. Just tear out this ad and send it today with your check for \$5; or tell us to bill you. Address: Barron's, 392 Newbury Street, Boston 15, Mass. E-261



ELKS NATIONAL FOUNDATION

"The Joy of Giving"



Silver Dollars for the Foundation

A successful means to bring in donations for the Elks National Foundation was recently brought to our attention by Adam Fondrk, Jr., Exalted Ruler of Leechburg, Pa., Lodge. It was passed along to us with the thought that other lodges might be interested in taking up this means to help Grand Exalted Ruler Fenton reach one of the important goals in his program for the year—increasing the Principal Fund by at least \$1,000,000.

The board pictured is 24 x 30 x 3/4 inches. Into this board are drilled 100

holes the exact diameter and thickness of a silver dollar. The board is varnished and the edges are finished in chrome molding. The lodge steward sold silver dollars to the lodge members for one dollar each. The silver dollars were inserted in the board and the name of a donor printed below each filled hole. "It took us eight weeks to fill our first board," writes Exalted Ruler Adam Fondrk, Jr., "and we plan to try and fill it twice a year. With this method we have taken out a \$1,000 subscription to the Elks National Foundation."

Grand Exalted Ruler John E. Fenton presents "Most Valuable Student" Award to Linda G. Eichorn of Methuen, Mass., at his home lodge, Lawrence, Mass. With them (right) is Lawrence Exalted Ruler Peter V. Winn. Miss Eichorn is presently attending Bates College in Maine.



Members of Leechburg, Pa., Lodge displaying coin board are, from left: Past Exalted Ruler John W. Taylor, R. B. Myers, Foundation Chairman Eugene Jack, E.R. Adam Fondrk, Jr., and Walter Slonaker.



ELKS NATIONAL FOUNDATION

where every dollar contributed becomes a source of good work, untouched by expenditures of administration.

ELKS NATIONAL FOUNDATION, PAST GRAND EXALTED RULER
JOHN F. MALLEY, CHAIRMAN, 16 COURT ST., BOSTON 8, MASS.

NEW GIFTS and IDEAS THAT SAVE YOU MONEY and TIME!

SPECIALS FOR DO-IT-YOURSELF

75c ea. for finest quality imported

PRECISION PLIERS

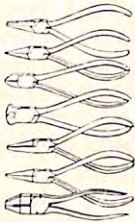

Flat Nose, Combination, Diagonal Cutter, End Cutting, Nippers, Round Nose, One Side Flat—One Side Round, Snipe

FOR JEWELERS, OPTICAL WORKERS, HOBBYISTS, CRAFTSMEN OF ALL KINDS! These superb European instruments are of deep-forged heat treated high quality tool steel fabricated to most exacting specifications. Jaws meet perfectly to safely and securely hold even the most delicate objects in the hard-to-reach corners and angles. Each plier is 4" long and a veritable gem of precision and strength.

75c ea.—all 7 for \$5.00 ppd.



INSTANTLY & CLEANLY REMOVES OLD PAINT!

ELECTRIC PAINT SCRAPER

No matter how many layers of old paint, cellulose or varnish on any surface, this amazing electric scraper will cleanly remove it all—INSTANTLY! Does away with old-fashioned dangerous blow-torches and chemicals—guarantees against burnt woodwork! Just plug into any AC or DC outlet and you're ready to cut hours of labor into minutes. Imported from England. Ideal for professional and amateur. Complete with nine feet of heavy-duty wire. 110 volts.

Imported from England **\$10.95**
Our Price

ALL WEATHER PROTECTION FOR YOU AND YOUR CLOTHES COVERALLS



In Handy Fold-A-Way Pack

One of the most comfortable, toughest wearing coveralls available anywhere! Custom designed one piece, roomy cut tear-resistant construction. Full length zipper—goes on and off in an instant! It's rugged, durable, lightweight, 100% waterproof! Not affected by oil, grease, mildew, or ordinary chemicals. Guaranteed not to crack, stick or peel in temperatures as low as 50 degrees below zero. Indispensable protection against soiling clothes when changing tires. Ideal for Fishermen, Outdoor Workers, Gas Station Attendants, Hunters, Farmers, Delivery Men, Golfers, Gardeners, Heavy House Cleaning Chores, etc. Specify size desired—

Small, Medium, Large. **\$3.98**



60 Pc. Set CHROME VANADIUM Wire Gauge DRILLS

Top quality German import high test Chrome Vanadium Drills designed for speed drilling through toughest steels, woods, plastic, iron and aluminum. Precision ground long-lasting cutting edges. Guaranteed to give years of satisfaction. A full 60 pc. set Nos. 1 thru 60. **\$5.95**

plus 35c pp. and hdlg. Same set above available with Huot Metal index container. **\$7.50** plus 35c pp. and hdlg.

Also available—20-PC SET NOS. 61-80 WIRE GAUGE DRILLS **\$2.50** plus 35c pp. and hdlg. Finest steel! Tops for precision work in woods, plastic, iron, aluminum, etc. Includes plastic kit with marked pocket for each drill. **ppd.**



DRILL SET

Especially made for speed drilling. In sturdy plastic tool roll. Finest alloy steel drills hardened and precision ground to the sharpest, longest lasting cutting edge obtainable; will easily and cleanly bite through hardwoods, plastic, aluminum, iron and the toughest steels. Unconditionally guaranteed for thousands of drillings. Full length. Sizes by drill from 1/16 to 1/2". There is only a limited quantity of these imported German sets available at this low price. **NOW \$6.95** plus 35c pp. & hdlg.

Also available with Turned Drills. In individual pocket roll Down Shanks to fit all 3/4" **\$8.95** plus 35c pp. & hdlg.

"HEAT-PAL"

Controlled Combination Heater-Stove
Leakproof — Spillproof — Explosionproof
GREAT FOR HUNTERS + ICE FISHING + FOOTBALL GAMES

Keeps you cozy, warm and comfortable in tent, shack or cabin in coldest days—doubles as top quality cook stove.

European ingenuity developed the first really EFFECTIVE space-heater with the ability to produce as much heat as you desire almost INSTANTLY. Merely by adjusting the handy outside volume control, you can achieve the full gamut from low-low to intense high heat. Control slides out-of-sight when not in use.

The HEAT-PAL is not just a "stove in a can" but a scientifically designed sturdy stove, and gramaire unit with precision made internal units, guaranteed to give you a lifetime of service. Steel fuel container is crammed full of non-inflammable absorbent substance that "soaks up" the alcohol, then releases it as desired for heating or cooking in a series of "gaslike" flames.

Steel body of HEAT-PAL has a red lacquered finish with upper portion made of heavy duty spun aluminum with special vents to emit the greatest possible amount of heat. For cooking purposes, steel grill is supplied adjustable to varying heights to accept different sized pots and pans.

Using inexpensive, easily denatured alcohol (or lacquer thinner) gives you up to 20 hours of heat from only 1 1/2 pints of fuel. There is absolutely nothing to go wrong—can be used anywhere such as in a boat, on dry grass, tent, cabin—even in a child's bedroom!

Also available 2-pint Reserve Fuel Container, \$1.98

No. 333
\$19.95



WINDPROOF SMOKELESS ODORLESS + WATERPROOF NON-TOXIC ECONOMICAL



"HEAT-PAL" as a stove.



"HEAT-PAL" closed with well strap handle.

Delayed Action Light Switch for Home or Auto



Amazing Delayed Action Safety Control Provides Full Light After The Switch Has Been Turned Off...

THEN SHUTS LIGHT OFF AUTOMATICALLY ALMOST 60 SECONDS LATER!



Invaluable in the home for Porches, Hallways, Stairways, basements, and garages. Now turning out lights won't leave you in total darkness. You'll have plenty of time and light to get where you're going before the light goes out automatically! Perfect for elderly people and children. Quickly installs into any standard Wall switch opening. (E-142) HOME DELAY ACTION **\$2.95**



PATHFINDER delayed action safety switch for AUTOMOBILES easily installed in any automobile or truck. Allows you to leave your car with a lighted path for 75 or 130 ft. Then automatically shuts your CAR LIGHTS OFF. (E-143) CAR DELAY ACTION **\$2.95**

Both Models are fully Patented and Approved by Underwriters Laboratories, Inc.

30 POWER ACHROMATIC TELESCOPE

Precision-made by one of Japan's top optical instruments mfrs. This 30 x 30 m.m. telescope brings distant objects right up close—with needle-sharp, color-free viewing that only genuine achromatic lenses give you. Chromium-plated draw tubes extend to 13 1/2". When collapsed, telescope fits into a snap-closure plastic case. 7 1/2 x 1 1/2", with leather carrying strap. Ideal telescope for study of birds, animals, stars, planets. For boating and sport use. Handy as spotting scope, too. **only \$6.95**



SHAPE SCRAPER
only **\$1.98**

SCRAPES AWAY OLD FINISHES. Precision engineered tool with six quickly interchangeable blades to fit almost any surface contour. Gets into corners even sandpaper cannot reach and does away with old-fashioned methods of scraping, making all your "do it yourself" work professional. Handle is durable, high impact Bakelite. Long-lasting blades are tool steel and reversible. Perfect for outdoor motor boats, yachts, moldings, picture frames, window-sashes, antiques... all furniture. Only \$1.98 plus 25c shipping handling.



Rugged 6000 Lb. Test NYLON TOW CABLE

If ever stuck in snow, mud or ditch, there's nothing handier to have in your car than a super-strong, All Nylon Tow Cable. Test proven to over 6000 lbs. pull, more than enough for even the biggest trucks and cars. One end has heavy steel snap clamp while other end is looped. Measures 15 ft. long. Also invaluable in **\$2.98** plus 25c home and for industry. **pp. & hdlg.**

Send Check or Money Order.

If C.O.D., \$2 Deposit. Money Back Guarantee.

GOLFER'S SCORE CADDIE

Only \$2.95



Golfer's score caddy may not improve his game but it will let him score his strokes without getting out card, pencil! Works like a wrist watch, our precision made scorekeeper registers total for EACH HOLE on lower window—total for COMPLETE COURSE on upper window. Polished goldplated case with smart pigskin strap is nicely gift-boxed. Grand for lady duffers. **\$2.95** too!

MONOGRAMMED MONEY BELT

Genuine Leather \$3.98



Genuine top-grain cowhide belt will add a handsome note to his attire, while "secret" zippered inner pocket holds currency far from prying eyes. Conservatively fashioned 1 1/2" wide belt is cinched with a gleaming buckle sporting his 2 or 3 initials. Available in brown top-grain cowhide leather with gold-plated buckle or black leather with a silvery rhodium buckle. Specify waist sizes 28 to 41 and color. **\$3.98**

NOW! Shut Out Cold, Wind, Water, Snow... Keep Garage Warm and Dry ALL WINTER with...

Flexible Rubber GARAGE DOOR BOTTOM



Don't waste precious heating dollars! Keep heat in with this amazing heavy-duty live rubber weather-stripping. Ingenious front and back lip contour design makes it an automatically perfect closure regardless of shape of floor. Guaranteed never to harden, rot or deteriorate. Eliminates forever ear-shattering noises no matter how hard you slam down your overhead garage door. Ideal also for sides of double hung garage doors, barn doors, etc. Permanently applied in only 10 minutes with just a hammer—we supply nails. Complete, simple instructions in plixofilm pack. 9 foot strip **\$2.98**, 16 foot strip **\$4.98**... plus 25c pp. & hdlg.

Magic Brain Calculator



Amazing new pocket-size machine adds, subtracts, multiplies and divides to 9,999,999—like lightning! Check your shopping, bank balances, etc. Does all your figuring—with never an error. Helps children with school work too. Fast, accurate, noiseless—easy to use. Steel construction light weight. Comparable to models now selling for \$2.98—**OUR PRICE 1/2 less, \$1.00**

FITS ANY 1/2" ELECTRIC DRILL Hardened Steel ROTARY RASP

Rasps, Shapes, Planes and Mixes in a Jiffy! No home, farm, garage or shop can afford not to have this ingenious Rotary Rasp. Snap into the chuck of your 1/2" electric drill and it's ready for use. Perfect for fast shaping of furniture, rasping of wood, plastic, fibre, etc., planing of floors, boards and mixing of oils, paints **\$1.98** and other heavy liquids. 2 3/4" in diameter—1 1/2" wide **plus 25c pp. & hdlg.**



EMPIRE MDSG. CO., Dept. EK2, 140 Marbledale Road, Tuckahoe, N.Y.

“Total Disarmament”

By GARRETT UNDERHILL

THE PICTURE of a nuclear world stripped down to customs inspectors and policemen directing traffic in Red Square or Fifth Street & Main is a beautiful hope. But is it practical? Could the Russians really accept the thorough inspection of their factories and country that would be necessary? Could we? Even if both countries inspected each other to their mutual satisfaction, would it not still be possible to develop secretly new ways to wage war? Might not our inspectors (or theirs) miss unorthodox weapons simply because they couldn't imagine what to look for? What does history have to say about this? How “total” would “total disarmament” have to be? Would it mean closing down West Point, Annapolis and Colorado Springs? Would it include doing away with border guards and internal security police—all armed and organized along efficient military lines today—throughout Russia and its satellite “colonies”?

Unhappily, history proves that “total disarmament” is impractical nonsense. After the First World War, Germany was almost totally disarmed. Within a few years the Germans were rearming secretly—and in more powerful ways than ever before. Forbidden the old methods of waging war, they found new and better ways. They dreamed up, not only radically new weapons (including rockets), but came up with better ways to handle men. By the outbreak of the Second World War in 1939, they had more power for less effort—and that is precisely what every military commander, and certainly every potential aggressor, wants.

A brief review of how the Germans went about secretly rearming between 1919 and 1935 (when Hitler openly announced that Germany would continue to rearm) has great meaning today because any really important disarming by either the communist or Free World blocs would be dangerous and impractical if either bloc were able to rearm in secret.

GARRETT UNDERHILL, primarily a military specialist, is considered one of the foremost authorities on Russian infantry weapons, tanks and other equipment. He has for many years viewed the Russian menace with alarm and has made an intensive study of Soviet matériel. For five years he was military editor of Life Magazine and during World War II was technical and then chief editor of the Army's Military Service publications.

In the decade that followed the Treaty of Versailles, America and Britain, sincerely inspired, were convinced of the possibility of disarmament and lasting peace. This feeling was climaxed in the 1926-28 period with the signing of the Kellogg-Briand Peace Pact which proposed to “outlaw” war—as impractical a legal “prohibition” as Prohibition itself. At the precise time that we and the British were striving hardest for disarmament, Germany—with Russian, Swedish, Spanish and Swiss connivance—was starting to rearm secretly.

During Germany's supposed disarmament, the Allies successfully abolished the German General Staff, for instance, but didn't abolish the “stag hunting societies,” some of which served as a convenient cover for command and staff groups going over forests and fields to work out actual battles. Rommel, who was destined to become one of the most brilliant and able commanders on either side during the war, developed his first important book on tactics by taking a motorcycle trip over the World War I battlefields in Italy. What was to prohibit such a trip? He was in civilian clothes; he was technically a tourist; he actually took his wife along and Frau Rommel rode around the battlefields, perched on the back of the motorcycle.

What the Germans couldn't cover up inside their own country, they developed with the cooperation of their neighbors. The Junkers Ju-87, which became the famous Stuka dive-bomber, was developed in Sweden by the Junkers-controlled A. B. Flugindustrie. Work on what became the Focke-Wulf planes went on in Japan. In 1931 the Germans transferred their Argus Engine Works to Russia, where they began development of rockets patented by Paul Schmidt. The success of these experiments in Russia led to the establishment in Germany 10 years later, in 1942, of the revolutionary V-1 flying bomb then known as the “Argus-Schmidt Project.”

With Russian help, the Bavarian Motor Works Model VI aircraft engine was converted as early as 1932 into a tank engine—affording the Russians, as well as the Germans, a lead in tank design which the Soviets hold to this day.

When the war began, the *Luftwaffe* had the best aircraft guns in the world—thanks to the groundwork done in neutral Switzerland by two firms in

which Germany's Rheinmetall Corporation (51 per cent government-owned after 1926) had an interest. The great German arms engineer, Theodor Rakula (brought to this country after the war by the U.S. Navy) worked for the Oerlikon gun makers in 1930-31, and then for Solothurn, where he was joined by Dr. Richard Braun, a Rheinmetall scientist. In 1934, just before Hitler openly sounded the military trumpet, both men returned to Germany—and both acknowledged that they had already worked out the theory and practice of superior aircraft guns.

These examples of secret rearmament are not cited to rake up old coals—although having seen our civilization badly burned by these coals some raking may be in order—but to introduce the next great problem that “total disarmament” poses. In modern industrial life, civilian and military goods and research are so closely knit that it is impossible to determine where civilian goods end and military armaments begin. Surely there is nothing aggressive or military if you and your family sit down before your TV set and eat a pre-cooked, frozen TV dinner. Yet the basic research behind the frozen TV dinner was first developed after World War II for bombing crews of the U.S. Air Force on long missions.

Perhaps no one ever put the practical problem of how difficult it is to distinguish between war matériel and civilian goods better than British Brigadier General J. H. Morgan who served from 1920 to 1927 on the Allied Control Commission that tried to keep Germany disarmed. The questions General Morgan raised are the same that would come up hourly if, under some plan for total, or even deep disarmament, we were inspecting Russia or Russia was inspecting us.

Aside from the obviously apparent armaments, aircraft carriers, for instance, the problem defies definition. “Is a field kitchen war matériel? Or a field ambulance? Or a truck?” asked General Morgan. “All three are capable of civilian use. When are you to call a spade a spade, and when do you call it an entrenching tool? How are you to distinguish between war explosives and ‘commercial’ explosives? How was the Control Commission to regard the vast stocks of nitric acid and the plants which manufactured them—the German chemical factories? Were we to stigmatize them as ‘war matériel’ and destroy them and all the plants which

Khrushchev calls for "Total, complete and immediate disarmament." Is this in any way practical—or are the Russians just being disarming? There is a deadly difference

made them? If we had, we would have wiped out the German chemical industry. . . . Nitrogen compounds are at once the most lethal and the most vital of chemical agents, a source of life and instrument of death. Nitrates are equally indispensable as fertilizers and as explosives. Or chlorine—the innocent and unsuspected agent of the dyeing and bleaching industries before the war until it was revealed, in March, 1915 on the fields of Ypres, the dark secret of its potency for the most insidious of all forms of warfare."

The fact that virtually all technology

has both civilian and military applications makes cheating on disarmament almost, if not completely, impossible to detect, even in the case of what seem obvious arms. In tanks, for example, the most difficult engineering design and development problem is the so-called "power train": the engine, the caterpillar tracks and the connecting machinery. Once the "power train" is perfected, the development of the armored hull and armament can be done with relative ease and speed. But the same holds for caterpillar tractors for civilian use in agriculture and con-

struction. The German tank development for World War II began in 1926 with a 9-ton tank built under the name of a "light tractor". The famous Mark I tank came into being under the "cover name" of *Landwirtschaftlicher Schlepper I* (Agricultural Tractor Model I). And the Germans got away with it!

Similarly, in 1926 all German commercial flying was consolidated in a single state-owned and operated airline—*Deutsche Lufthansa*. All flying training was consolidated in three Air Ministry-run flying schools. When in 1935 Hitler denounced the armaments-limiting Versailles Treaty and proclaimed an open rearmament program, what do you know? Large parts of *Lufthansa* turned out to be the new *Luftwaffe*, and the flying schools its "West Points of the Air." The principal *Lufthansa* passenger and cargo transport planes, the Junkers 52's, turned out to be usable as military cargo and paratroop transports, but also proved to be quickly convertible to bombers, complete with defensive machine-gun positions. As such they helped Franco's Nationalists in the Spanish Civil War.

Today, Khrushchev likewise has a state airline—*Aeroflot*—which is expanding rapidly its domestic and international services the way *Lufthansa* did in the days of German camouflaged rearmament. The famous Tupolev Tu-104 jet transport is a dead ringer for the Tu-16 jet bomber. The giant Tu-114 intercontinental turboprop transport, the largest "commercial" plane in the world and the one which brought Mr. K. to visit America on a 12-hour nonstop flight from Moscow, bears the same similarity to the Tu-20 intercontinental bomber.

In fact, except that they have a passenger deck and "cargo and baggage holds" below instead of bomb bays, the Tu-114's are essentially the same as their bomber counterparts. Both have the same flight deck layout for their crews. The navigator, instead of sitting behind the pilots as in free world transports, is down in front in a glassed-in bomber-type nose, complete with flat optical-glass visual sighting panel through which (the Soviets say with a smile) he takes visual readings by means of a "drift meter"—an instrument which is suspiciously like a bomb sight. The Tu-114 can detect storm turbulence and aircraft with which it might collide, as can radar of free world commercial transports; it can also map the

(Continued on page 55)



BATTLE

By AL STUMP



Baltimore Coach Weeb Ewbank on phone with spotter in the press box.

KICKOFF TIME for the Baltimore Colts was four hours away. Johnny Unitas shook hands in the hotel lobby, politely veering around the subject on his mind, then getting to it. He said, "What's this I hear about you sitting with us today?"

"That's right," I said, showing him my specially-issued pass, good for one seat on the Colts' bench.

Unitas gave me the sort of look the Secret Service reserves for gentlemen in slouch hats who loiter around missile bases, rubbed his jaw and said, "Well, we've never done that before. We've got a tough game today. Toughest of the whole season."

The concern of the Colts' great quarterback was easy to understand, for there's always the suspicion that spies lurk everywhere in the National League. It wasn't so long ago that a Chicago Bears' scout turned his back for a moment in an overhead booth and found his sheaf of game notes missing. Last season, Coach Bob Waterfield of the Rams charged that someone had tapped his scout booth-to-bench telephone during a game. Enough espionage has happened that NFL security measures rarely exempt anyone not di-

rectly connected with the team or its management.

Even a flatfooted, bespectacled reporter, located close to the firing line, might see or hear too much.

In this case, on a Sunday late this season, the situation was particularly critical. The Colts were matching muscle and wits with the Rams in the Los Angeles Coliseum before 80,000 fans in a game that could settle the Western Division championship. Seldom had the race been so tight in the home-stretch. Tied with Green Bay's surprising Packers and the San Francisco 49ers for first place, the defending champion Colts needed to win—or very likely see their hope for an unprecedented third straight title go glimmering.

And it happens that I am a long-standing resident of southern California, as well as author of a team history of the Rams.

After I had vowed neutrality, promised to obey certain rules of deportment, Executive Vice President Don Kellett waived tradition for a day and allowed me—as an ELKS MAGAZINE observer—the rare privilege of sitting amongst Unitas, Big Daddy Lipscomb,

Lenny Moore, Raymond Berry, Art Donovan and the other Hosses who'd chalked up all-league titles in 1958-59. It was a thrill and a big one. In 22 years around the pros, I'd never had a down-front look at the clashing of these giants, nor ever expected to experience that singular sidelight of football: life as lived on the bench during the high climax of a season's make-or-break game.

A mood begins to build in a pro team about two hours before combat . . . but it isn't verbal. Enroute to the Coliseum, the Colts withdrew within their individual selves. "We're angerizing," All-Pro Back Lenny Moore put it, tersely. Talk almost disappeared. The 38 men on the chartered bus turned invisible keys that wound them to a pitch few college footballers ever reach. It is the cold anger only the pro knows.

Moments after they trooped through the Coliseum players' gate, Head Coach Weeb Ewbank had his day's complex organizational plans under way. A clip-sheet in hand, he said, "John . . . Bill . . . Raymond . . . when you're dressed, see me."

Ewbank was talking to Unitas, Bill Pellington, his defensive captain, and Raymond Berry, the league's top pass-grabber. On this day, December 11, Unitas stood only 182 yards away from surpassing Sammy Baugh's ancient all-time record of 2,938 yards gained passing in a season. Berry was just 13 pass-catches away from the pro mark for receptions. Pellington, a 240-pounder from Rutgers, is a core man of the most effective defensive platoon (many believe) in NFL history.

In the locker room several large signs confronted the Colts: **FIRST PLACE IS THE ONLY PLACE.** Door guards were posted, a crate of oranges was unpacked for halftime refreshment and trainers and equipment men jumped into action. Trainer Eddie Block, who holds master's and Ed. D. degrees in physical therapy from Missouri U. and Columbia, commenced taping the players, taking especial pains with the tall, thin, bespectacled Berry. Right away, I stuck my nose where it didn't belong. "Anything wrong with Berry?" I asked, when the pass-catching king left the training table.

Block's face went blank. He ignored the question. "Next man," he said to the waiting Colts, and 288-pound Big Daddy Lipscomb heaved his mighty frame onto the table.

I walked away, quashed. An injury

REPORT from the Colt's Bench

A bench-eye-view of the violent, exciting game of football as played in the National Football League

to a man as important as Raymond Barry is kept as carefully concealed as a Polaris cruise, and, as I later learned, the lanky end was in no shape to play today. My question had been entirely out of order. Crippled by a serious leg injury, Barry could only be a threat to the Rams. But, until they discovered it, his presence might make the difference between winning and losing.

The silence in the dressing room was almost deafening. The 38 players were taped, suited up, sat in little two-man cubicles poring over their book of plays in almost religious concentration. A Weeb Ewbank locker room is 100 per cent business. In the Rams' quarters next door, a lusty bellow of laughter was heard.

Doctor Erwin Ed McDonnell, the slim, serious team physician, told me that few pro players are phlegmatic. "They don't play just for money. Proves how much they love the game. Right now this is a roomful of raw nerves. Best thing you can do today is not speak unless spoken to."

Seeking someone half-way relaxed, I entered the equipment room, a jumble of bench-side supplies. Freddie Schubach, a former Philadelphia Athletics catcher, is Baltimore's equipment chief and known as a genius at fast emergency repair of gear during games. Schubach had a big blue bag stuffed with auxiliary hip, thigh, knee and shoulder pads, an oxygen dispenser, face masks, cleats, eye-blackening, kicking tees, mouthguards, eye-visors (the Colts had the sunny side of the field) and a curious device I didn't recognize.

"In case a man swallows his tongue," said Schubach. "A guy can strangle if we don't get air to him fast." No Colt, as yet, has had his tongue driven down his throat by the impact the pros apply, but Frankie Albert, the great ex-49er quarterback, once almost died on the field from this cause. Norm Standlee, a teammate, pried his tongue loose just in time.

Kickoff time was 1:30. At 12:15, Unitas took over the main corridor of the locker room for his usual indoor passing warm-up, flipping 30-footers to Halfback Art DeCarlo. Typical of Ewbank's attention to detail, Unitas didn't catch the return throw. He might sprain

a finger. A sub quarterback, Ray Brown, received for him.

Out the taping-room door came 6-foot-3, 240-pound guard, Palmer Pyle, and almost got hit between the eyes by Unitas. The first light remark of the day was heard.

"I thought all elephants had memories," said Unitas.

When the Colts jogged onto the field in freshly-cleaned blue-and-white nylon, Weeb Ewbank did a number of things and did them rapidly. Ewbank is a miracle man among pro coaches. He's about the smallest NFL coach of all time, height considered. Weeb stands 5 feet 7 but he extends sideways to the amount of 182 pounds. Carroll Rosenbloom, the young industrialist who owns the Colts, calls him "my crew-cut IBM machine." Until 1957, when he'd lost 22 of his first 38 games as Baltimore coach, the chunky, pug-nosed Ewbank never was off the pan; dizzily, he was "fired" each day by the press, his job passed around to much bigger coaching names. But 53-year-old Charles Wilbur Ewbank comes from Indiana pioneer

stock and precision is his other middle name. He taught the Colts to jump at his command—better yet, to like it. These days, the team obeys a strict 10 p.m. curfew and lights out at 11. No wives may travel with the club. Any player who misplaces his playbook is fined \$200. Ewbank grades every man on every play of every game, poring over film 20 or 30 hours a week. "Few years ago I was up to 315 pounds," confessed Art Donovan, "and then Weeb stuck a clause in my contract calling for a \$50 fine for every pound over 270. That's \$2,250 I'm looking at!" Donovan sweated off 47 pounds and has stayed that trim ever since.

"Lots of clubs have regular weigh-ins," added End Gino Marchetti. "Weeb springs surprise weigh-ins on us."

However strict Ewbank is, he's close to his men. He'll buy a hard-trying Colt a beer on occasion. "Temperance with mercy," he calls it. On the bench, you get the feeling that he is associated with his players, not their whip-cracker.

At 1:05 p.m., Ewbank took a position
(Continued on page 51)



Halfback Lenny Moore, with ball, stopped on one-yard line by a Ram tackler, Jack Pardee. Colts then kicked field goal to take a three to nothing lead at half-time.

Bermuda & Nassau

By HORACE SUTTON

IF THE CLASS will come to order, I should like to discuss the differences between those two havens of refuge, Bermuda and Nassau. Both, of course, are members of the very same Empire on which the sun never sets (or at least never *used* to). When it is in the sky, the sun burns more brightly on these lushlands than many a less fortunate corner of the U.K. It also burns more brightly than on many a corner of the U.S., which is what makes both places so ruddy popular with our spring and winter refugees.

Now then, to get everybody placed geographically, Bermuda floats off the Virginia Capes, being roughly 670 miles and change south and east of New York. In effect it is 150 small islands, all massed more or less together, covering some twenty-two square miles of water-logged real estate. The Gulf Stream, that beneficent body of water, runs between its home territory and the mainland of North America, providing a warming influence that is not tropical. Therefore, days in February and March reach an average high of 68 degrees, a little chilly for swimming, with April up three degrees, and May a toasty 76. By June we're in the eighties, staying up there into October.

Nassau, on the other hand, is in the Bahamas, being south and east of Florida. The Bahamas, I had better tell you, so that you can be a veritable fund of information should anyone ever ask the question, comprise some 690 islands, not to mention 2,387 cays, which are pronounced "keys". This unkempt collection of territory is scattered like toys on Christmas morning, over 70,000 square miles of sea. Where the islands are, the sea turns blue, green, turquoise and several shades which would be indescribable to almost anyone except those types who think up names for new shades of lipstick. Being where they are, Nassau and the rest of the Bahamas strike a high of 77 in February, 78 in March, and move into the eighties by April. The peak of the rainy season comes in July, but the winter and early spring months are delicious and dry. The swimming is all year around.

Bermuda is a land of easy colonial

charm with virtually no industry extant except tourists and the care and feeding of same. It is also vastly concerned, once the tourists have landed, with selling them such things as perfumes, spirits, woolens from the Mother Country and porcelain from ditto. The shops of Hamilton are famous for all that, and my notes show that sleeveless cashmere sweaters for men run from \$18 to \$24. (When I last priced them in Saks Fifth Avenue they were \$27.50, hardly enough saving to make the trip just for *that*.) Ties were running \$3.50, shorts translated out at \$8.46 and cashmere blazers by Altmann of Austria came

to \$75. Tropical worsted Daks suits were \$75, slacks were \$24, and \$21 bought a Madras jacket. Biyella in faded tartans came to \$46. I give you all these shopping notes so that you can make a comparison with your own hometown haberdasher and decide for yourself whether it's bargainland or not.

As for the ladies, there is at last a deviation from the traditional Bermuda wear of sensible sweaters and sensible tweeds which would require the purchaser to look exactly like a sensible housewife from Surrey. Some of the more daring emporia now have launched into slacks of Siamese silk and lovely



BERMUDA NEWS BUREAU

Old St. George abounds with historic attractions such as this shop, where printing methods haven't changed since Bermuda was a new colony.



BAHAMAS NEWS BUREAU

The picturesque Nassau waterfront and open-air market caters to tourists and housewives alike.

silk brocades from France in the most daring colors.

The Furness ships dock smack in Hamilton, looming over the low houses like enormous monsters, albeit pleasant ones. The cruise ships, however, frequently pause in St. George's, a town which was founded in 1609 and has not changed very much since then. There is Printer's Alley where the first press was brought in, a stockade that dates from 1783 and the present branch of the Bermuda Library, which is housed in a building dating from 1703. You can dance underground at night in Gunpowder Cavern, a restaurant inside a tunnel where gunpowder was stolen one dark night in 1775 to supply the Revolutionary troops in America. Tiny fishing boats still find the cove at Tobacco Bay and unload their jackfish, announcing the catch in town with bleats from a conch shell.

There are big hotels in Bermuda and tiny guest houses, too, sort of a refined way of referring to boarding houses. Frequently, they are run by retired couples out from England. Best of all, to my taste, are the cottage colonies. Cambridge Beach is one, with an assortment of all sorts of accommodations on a narrow ridge of land bordered on both sides with beach. A boat sails into town a few times daily, a twenty-minute ride. In winter, cedar logs are burned in the fireplaces, but by spring-time the meals are served outside under the tamarisk trees on teak tables re-

claimed from an old British man o' war. Not far away is the newest resort of Lantana, where the cottages are built of coral, trimmed with cedar and embossed with names of far-off resorts.

Sun and sailing make Bermuda, with the help of long days at the beach. But spring is a sure season, when the lilies are in bloom and the college kids come out in droves for the annual convention on the perfumed isle off the Virginia capes.

As for Nassau, it is now only slightly more than three hours from New York by jet and practically a whoosh from Miami. As for Nassau itself, it dresses up its cops in white helmets and colorful trousers, and there are still horse carriages on Bay Street. The old hotels are getting older, but there are new ones now, a wide assortment and situated in the most agreeable part of the island. Nassau Beach Lodge and its neighbor, the Emerald Beach, are side by side on Cable Beach, a marvelous strand of sand, white and warm and lovely. Nearby is the Bahamas Country Club, to my mind one of the most agreeable places to stay on the whole outpost. Despite its formidable title, it is by and large open to the public, the meals are exceptional, the rooms hang over the beach, there is a golf course a few steps away, and, well, who could ask for anything more? And nights, not to mention the luncheons, are filled with music.

Nassau, of course, is in the shopping

business too, with by and large the same sort of goods. Perfume and golf balls seem to be the big thing here, not to mention whisky. The scents, as the British are fond of calling them, run almost half of the tax-included U.S. price. A dozen golf balls (unless you don't care, better check that they are the British small size) I priced were \$7.95 against an alleged tag of \$13.50 here at home.

One exclusive bazaar is Nassau's straw market which sells bags, shoes and hats, both handsome and outlandish. Some of them, favored by American tourists, have straw stove pipes three feet high. Anyway, a stroll through the straw stalls is a pleasant way of frittering away an hour if for nothing more than the sweet talk that emanates from the genial salesladies who have manufactured their own brand of the Queen's English. Nearby, the native market, where tourists rarely browse, offers such sights as papayas the size of footballs, sugar apples, tiny limes, and miniscule peppers. Boats tied up at dockside carry sheep, goats, pigs and chickens into Nassau and return to the outer islands with soda pop and beer.

The out islands beyond Nassau are varied and many. Among the most famous is Eluthera, which was begun long years ago by a Company of Adventurers who put out from Britain in search of freedom. They used the
(Continued on page 30)



A forefinger on the action handle shows facility of single-shot loading with Remington's "Nylon 66".

Rifles—**NOT** Trifles

By **DAN HOLLAND**



Winchester's glass-barrel shotgun at work in the field.

Here are two new milestones in gun design

WHAT'S GOING ON around here? What are American gun makers up to? A couple of years ago Remington brought out a nylon .22 rifle. Yes, nylon. The barrel is made of steel, but the stock, fore end and much of the breech mechanism are actually made of nylon. That was a shocker. Then Winchester came along and produced a shotgun with a glass barrel. That did it. I needed one more shotgun about as much as I need another left foot, but I took my hard-earned cash out from behind the loose brick in the chimney, dusted it off and bought one of the things. I had to see and shoot a glass-barreled shotgun to believe it.

Are these guns gimmicks? Are they manufactured simply to shake gunners loose from their shekels? Is there any possible excuse to make a rifle of nylon, or a shotgun barrel of glass?

Here are the answers as I see them. These guns are not toys nor trifles. They were not conceived merely as sensational promotional stunts. They came into being as a result of purposeful study, testing and deliberation. The motives behind them were strictly practical ones.

What's so practical about nylon in a gun? First, it's durable. No one wants to mistreat (Continued on page 42)

Lodge Visits of JOHN E. FENTON



In a photo taken at Judge Fenton's lodge, Lawrence, Mass., Nov. 3 (front row, from left): Brothers J. A. Lane, W. T. Meaney, H. V. McGovern, District Deputy M. J. Bowen, the Grand Exalted Ruler, Exalted Ruler P. V. Winn, George Wilson, Past District Deputy F. L. O'Neill. Rear: Chaplain Patrick Fennessey, State

Vice Pres. T. J. Dowd, John E. Fenton, Jr., (Secretary to Judge Fenton), Special Deputy J. J. Harty, Grand Lodge State Associations Committee Chairman William F. Maguire, Past District Deputies R. M. Dowe, C. M. Duran, Brothers Richard Croteau, W. A. Coyle, E. P. Menard and Francis Clark.



Gathered at Bedford, Pa., Lodge on Nov. 14 are (from left) State Vice Pres. Barney Zellers, Past State Pres. J. S. Buchanan, State Pres. Meryl Klimesmith, Grand Secretary Lee A. Donaldson, the Grand Exalted Ruler, Exalted Ruler N. C. Bachellor and Lodge Secretary H. C. Bingham.

Heading West

GRAND EXALTED RULER John E. Fenton has already visited subordinate lodges in almost every section of the country; and in a series of recent visits, reported here, he went from Rhode Island—one of our easternmost States—westward all the way to Nebraska.

PAWTUCKET, R. I. On an official visit to Rhode Island, Oct. 9, Judge Fenton was greeted at the Massachusetts state line by a delegation including State Pres. Marshall S. Yemma and District Deputy E. L. McWilliams, who accompanied him by motorcade to Pawtucket Lodge. There, a reception and dinner were held in honor of the Grand Exalted Ruler, with a very large attendance at-



About to dine at Brookings, S.D., Lodge on Nov. 21 are (from left, seated) District Deputy R. A. Curtis, Rev. Father John J. McEneaney (who is related to Mrs. Fenton) and Past District Deputy Ross Case. Standing: Past District Deputy Fred Green, Judge Fenton, Mrs. J. W. Garrity and Exalted Ruler Garrity.



Grand Exalted Ruler John E. Fenton and Past Grand Exalted Ruler John F. Malley meet with trustees, Past Exalted Rulers and officers of Lowell, Mass., Lodge on Nov. 1. Exalted Ruler P. E. Smith, Judge Fenton and Past Grand Exalted Ruler Malley may be seen in first row—second, third and fourth from left.



Pennsylvania Elks welcome the Grand Exalted Ruler to Latrobe Lodge on Nov. 14. Shown (left to right) are State Tiler A. J. Gareis, Judge Fenton, Past State Pres. F. J. Benson, Grand Secretary Lee A. Donaldson, Exalted Ruler J. P. Watt, State Pres. Meryl Klinessmith and District Deputy Jack Gould.



While visiting lodges in South Dakota, Grand Exalted Ruler Fenton stopped in Watertown for an informal visit with Past Grand Exalted Ruler James G. McFarland. The two distinguished Elks are shown here just before Judge Fenton's departure for Brookings Lodge, Nov. 20.



Photographed prior to a dinner at Butler, Pa., Lodge, Nov. 15, are (from left) State Trustee Boyd Adams, District Deputy Harry Pepper, State Pres. Meryl Klinessmith, Exalted Ruler K. E. Atwell, Judge Fenton, County Judge C. S. Shumaker and Grand Secretary Lee A. Donaldson.

tributed to thorough advance newspaper publicity. The official party on this occasion included Past Grand Exalted Ruler John F. Malley, Grand Trustee Edward A. Spry, Grand Lodge State Associations Committee Chairman William F. Maguire and Special District Deputy John Harty. Secretary to the Grand Exalted Ruler, John E. Fenton, Jr., and Mrs. Fenton made these visits with Judge Fenton.

MASSACHUSETTS. In company with Past Grand Exalted Ruler Malley, Judge Fenton visited Lowell, Mass., Lodge on Nov. 1. They were welcomed to a well-attended reception and dinner by Exalted Ruler P. E. Smith, Lodge Secretary F. V. Redding, Past Exalted Ruler P. R. Fitzgerald (chairman for the visit) and Past Exalted Ruler F. L. Lappin (toastmaster for the occasion).

The Grand Exalted Ruler and District Deputy M. J. Bowen together visited Judge Fenton's home lodge, Lawrence, on Nov. 3. The meeting room was filled to capacity as Judge Fenton addressed the Elks of Lawrence, thanking them for a \$1,000 pledge to the Elks National Foundation. Dr. Maguire and Mr. Harty were present during this visit, too, as were State Vice Pres. T. J. Dowd, Past District Deputies R. M. Dowe and C. M. Duran, Exalted Ruler P. V. Winn and Lodge Secretary F. L. O'Neill.

PENNSYLVANIA. The Elks of Ashland, Pa., honored Grand Exalted Ruler Fenton on Nov. 13 with a testimonial dinner to which 225 Elks and their ladies came—not only from Ashland but from neighboring lodges as well. Exalted Ruler C. H. Gough welcomed Judge Fenton, Grand Secretary Lee A. Donaldson, Past State Pres. B. W. Wentz and the other guests during this visit—the first to Ashland by a Grand Exalted Ruler. The lodge presented \$2,600 for the Elks National Foundation, and this was increased to \$5,100 by pledges from nearby lodges.

Next day, Nov. 14, Judge Fenton visited Bedford, Pa., and Latrobe Lodges with Grand Secretary Donaldson. At a luncheon given by Bedford Elks, another gift to the Elks National Foundation was made, this time of \$4,200, with Past Exalted Ruler E. A. Davidson making the presentation on behalf of the lodge. Among those in attendance were State Pres. Meryl Klinessmith, Past State Pres. J. S. Buchanan, State Vice Pres. Barney Zeller, Exalted Ruler N. C. Bachellor and Lodge Secretary H. C. Bingham.

Judge Fenton's visit to Latrobe included a tour of St. Vincent College under the guidance of the Reverend Edmund Cuneo, Director of Public Relations for the College. The host was the Right Reverend Denis O. Strittmatter, President of St. Vincent. Although this tour was gratifying and informative, the occasion was a sad one, for State Pres. J. P. Ebersberger, who had been active in making the arrangements, passed away that morning. Lodge Secretary A. J. Gareis had arranged the tour with Mr. Ebersberger. Among the other Elks present were Grand Secretary Donaldson, Grand Lodge Activities Committee Chairman Nelson E. W. Stuart, State Pres. Klinessmith, Past State Pres. F. J. Benson, District Deputy Jack Gould, Exalted Ruler J. P. Watt and charter members Ed Anderson and Robert Householder.

Three more lodges were visited on Nov. 15, when Judge Fenton called on Elks in Butler, Grove City and

Sharon. Brothers Donaldson and Klinessmith also accompanied him on these visits. At a luncheon meeting in Butler, Judge Fenton commended local Elks for their fine efforts to increase membership. Present at the luncheon were State Association Trustee Boyd Adams, District Deputy Harry Pepper, Exalted Ruler K. E. Atwell and Butler County Judge C. S. Shumaker, a Brother Elk.

During the afternoon, the official party proceeded to Grove City, where a fine turnout of Elks was on hand to greet them and to present \$4,000 in donations and pledges for the Elks National Foundation. The presentation was made by George Plance, Lodge Chairman for the Foundation, and Committee member Raymond Turner.

A testimonial dinner was given for the Grand Exalted Ruler that evening by Sharon Lodge and the Pennsylvania West District of the State Association. Owing to advance publicity in seven newspapers of the region, attendance was very gratifying, with 230 Elks present, representing lodges throughout the District. Fourteen Past District Deputies were there, as were Past State Presidents W. P. Baird and H. T. Kleeen, State Vice Pres. B. G. Baird and Exalted Ruler R. P. Jones, who conducted the program. Brother Baird carried out the presentation of a \$1,000 Permanent Benefactors Certificate and 55 individual participating memberships on behalf of the District and its member lodges—an immediate and heart-warming response to Judge Fenton's appeal for greater support of the Elks National Foundation.

SOUTH DAKOTA. Grand Exalted Ruler Fenton arrived in South Dakota on Nov. 20, and proceeded to Watertown for an informal visit with Past Grand Exalted Ruler James G. McFarland. After dinner with Past Grand Exalted Ruler McFarland and officers of Watertown Lodge, the official party went to the home of Brookings Exalted Ruler J. W. Garrity for a meeting with that city's Elks.

The following morning, Judge Fenton toured Brookings in the company of Rev. Father John J. McEneaney, who is related to Mrs. Fenton. During the afternoon he visited with South Dakota Elks at Brookings Lodge, and in the evening was honored guest at a banquet attended by Elks from all over the state. District Deputy R. A. Curtis, and Past District Deputies Ross Case and Fred Green were among the guests. Next morning, Judge Fenton breakfasted with Past Grand Trustee Ford Zietlow, District Deputy Curtis, Past District Deputy Green, Exalted Ruler Garrity and a number of local Elks, before boarding a plane for Omaha, Nebr.

OMAHA. Arriving in Omaha the same morning, Nov. 22, Judge Fenton went immediately to the lodge for a press conference with newspaper reporters and television interviewers. A delegation, headed by Esteemed Leading Knight A. W. Fries, Jr., and Lodge Secretary S. B. Kent, escorted Judge Fenton. Following the press conference, the group went to the Sheraton-Fontanelle Hotel for an informal luncheon, at which lodge officers and trustees were the hosts. Grand Exalted Ruler Fenton was then taken back to the airport in time to catch a plane for Lawrence, Mass. He was on his way home for Thanksgiving, before again tackling his arduous schedule of visits.



George Plance, Grove City, Pa., Chairman for the Elks National Foundation, presents \$4,000 in donations and pledges to Judge Fenton for the Foundation on Nov. 15. Looking on at left and right are State Pres. Meryl Klinessmith and Grove City Committeeman for the Foundation Raymond Turner.



Grand Exalted Ruler Fenton congratulates Ashland, Pa., Exalted Ruler C. H. Gough on the lodge's efforts in support of the Elks National Foundation. Grand Secretary Lee A. Donaldson appears at center in this photograph, taken on Nov. 13.



At Pawtucket Lodge during a Rhode Island visit, Oct. 9, are (from left to right) District Deputy E. L. McWilliams, Past Grand Exalted Ruler John F. Malley, Grand Lodge State Associations Committee Chairman William F. Maguire, the Grand Exalted Ruler and State Pres. Marshall S. Yemma.

For Those Who Do Not Want
GREY HAIR

Now **Top Secret's** amazing scientific formula gives a natural looking color to faded or grey hair. **Top Secret** makes you look years younger! **Top Secret** does not streak or injure hair, does not wash out.



"I noticed results after just a few applications," says Jan Garber, Idol of the Airlines. "Top Secret is easy to use—doesn't stain hands or scalp. Top Secret is the only hair dressing I use." Time-proven **Top Secret** has been used by famous personalities for years.



NEW! 13 oz. Giant Size \$9

Send \$5 (Fed. Tax incl.) for 6 oz. plastic container, convenient for traveling, too. Ppd. No COD's, please. Money back if not delighted with results of first bottle! **Albin of California**, Room 24-91, 8100 Vanowen St., Burbank, Calif.

JOS. E. ROCKWELL-682

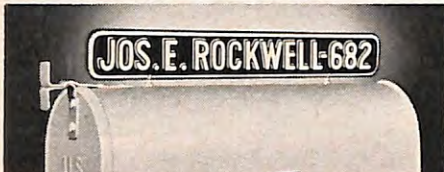

Day-n-Night Mailbox Marker . . \$1.95

Your name (or any other wording you want, up to 17 letters & numbers) appears on both sides of your Day-n-Night Mailbox Marker—in permanent raised letters that shine bright at night! Fits any mailbox—easy to install in a minute. Rustproof—made of aluminum; baked enamel finish, black background, white letters. Your marker shipped within 48 hours. Satisfaction guaranteed or money back. Only \$1.95 postpaid from

SPEAR ENGINEERING COMPANY
480-F Spear Bldg. Colorado Springs, Colo.

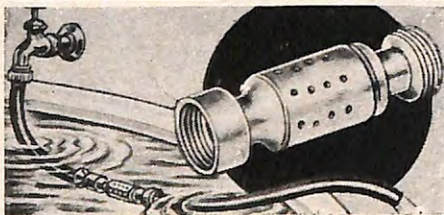

PUMP WATER DRY—SAVE MONEY

SUCT-DRI

Only \$2.75

postpaid

Without electricity or moving parts this suction drain pumps 200 gallons of water per hour from flooded cellars, pools, trenches, washing machine, etc. Just attach with a garden hose to any screw-type faucet, attach another section of hose to the discharge end, turn on the water and it goes to work. Mail your order today.

MEDFORD PRODUCTS, Dept. EL 2, Box 39, Bethpage, N.Y.



FREE!
100
WORLDWIDE
STAMPS . .
just released!

RUSH REPLY for your new, **FREE** collection of 100 all-different Worldwide stamps. Newest issues of the year—pictorials, commemoratives—bi-colors, mint and used. Get Togo "Summit Meeting" stamp, Netherlands KLM, South African Antarctic, colorful mask stamp of new Upper Volta Republic, many more. Supply limited, only one to a collector. Send for this valuable free collection and other stamp offers on approval, today. Rush reply, 10¢ for handling to **GARCELON STAMP CO., Dept. EM2X, Calais, Maine.**

FABULOUS, NEW

5-Ft. Long Balloons

Twist Into A Thousand Shapes!

GIRAFFES-DACHSHUNDS—Pets of All Kinds

Made of LIVE LATEX **200 FOR \$1** Add 25c Postage and Handling

Delight Kiddies—Grown-Ups, Too!

Almost 5 feet long when inflated. Balloons this size usually sell up to 25c each.

Sell only \$1 now. Plus 25c postage and handling for 200 in a variety of gay colors! Supply limited at this low price, so order several sets **NOW** for **GUARANTEED PROMPT DELIVERY. MONEY BACK GUARANTEE.** FREE Complete Instructions.

MURRAY HILL HOUSE

Dept. B-725-C, P. O. Box 251, Bethpage L. I., N. Y.



ELKS



FAMILY ARMS TRACED and emblazoned on an Oak Wall Shield. For \$7.00, York Insignia Co. will trace through old records filed under 100,000 British and European surnames and emblazon your family arms in relief and full color on 7" x 6" shield. Check is returned if arms cannot be traced. Larger sizes to \$25. York Insignia Ltd., Dept. E, Albany Hall, York, England.



PERSONAL EMBOSSEER. You can turn plain notepaper into expensive-looking stationery with handy all-steel embosser. It makes raised letter impressions of your name and address on notepaper and envelopes to give them an embossed look. Particularly handy for clubs. \$4.98 ppd. Print 3-line name and address. Sunset House, 75 Sunset Bldg., Beverly Hills, Calif.

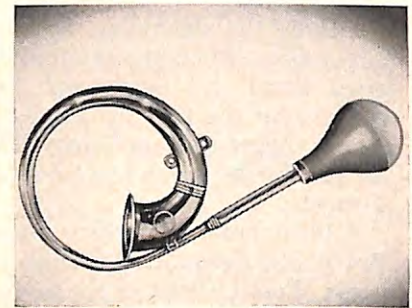

20" BOMBAY TAXI HORN, used in 1900 on horse-drawn carriages, is still the favorite of taxi drivers in India. On sports car, family hack or collegiate Model A, its unique appearance and strident bellow attract as much attention as any horn made. Nickel on brass, it's 20" from bulb to curve, 44" around. \$12.95 ppd. Madison House, Dept. EK-2, 122 East 42nd St., N.Y. 17.

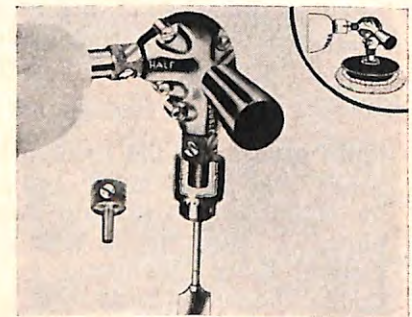

"ARCO 2-SPEED ANGLE-DRIVE" changes the speed of your electric drill for the best results in buffing, sanding and angle-drilling. Speed Reducer (1/2 speed) prevents burning and uneven finishes when polishing; double drill speed gives smoothest surface when sanding. Fits 3/4" electric drill. \$4.95 ppd. 1-yr. guar. Arrow Metal Prod., Dept. EL-2P, 421 W. 203 St., N.Y. 34.

Except for personalized items, there is a guaranteed refund on all merchandise returned in good condition within 7 days.



FOLDING BACK REST

Ingeniously improved Folding Back Rest gives you the joy of sitting-up support when you read, eat, doze or watch T.V. Provides 3 positions, especially selected for maximum comfort. Anchored by non-skid base. Elastic strap holds your own pillow where you want it. Folds "tuck-away" flat. Conveniently light. Smart wood grain finish. Gifts mailed direct. We ship immediately for only \$3.98 postpaid.

MONEY BACK GUARANTEE

BETTER SLEEP, INC., Dept. 469
New Providence, N. J.

INSTANT Glamour WIG

In Ten Breathless Colors to Match Any Outfit—Makes a Big Hit at Parties, Dances, Anywhere

- Black • Brown
- Dark Blonde
- Light Blonde
- Platinum • White
- Pink • Ice Blue
- Grey • Streak
- Blonde • Streak

no-twisting, darling, winsome, demure—Split second change to new personality. Find new adventures, be the life of the party, win admiring glances. It's the fashion rage. A very pretty cover-up after swimming, washing or setting your own hair (instead of unsightly ketchicles). Smooth, non-flammable Celanese acetate looks like real hair, feels luxuriously soft and lovely. **SEND NO MONEY.** Pay postman on delivery \$5.95 plus C.O.D. postage or send \$5.95 with order and save postage. Money back if not delighted. Specify color.



GUILD, 103 E. Broadway, Dept. W-348, N.Y.C. 2

FAMILY SHOPPER



GOLFER'S SMOKE SET. The ash tray is a golf club . . . the lighter a golf ball. So realistic they're a pleasant reminder that the fairway will soon be green again. Ceramic set is just right for office or home. The combination of Golf Ball Lighter and Golf Club Ash Tray is only \$1.98 plus 25¢ postage. Medford Products, Dept. E, P.O. Box 39, Bethpage, N.Y.



SELF-STARTER CALENDAR BANK almost forces you to save for it takes a quarter a day to make the date advance. You'll soon have money toward a prized goal . . . new car, home, vacation. Savings chart and key incl. with each bank. Order several. \$2.00 ea.; 3 for \$5.75; 6 for \$11.00. Add 25¢ post. per bank. Leecraft, Dept. ELE, 300 Albany Ave., B'klyn. 13, N.Y.

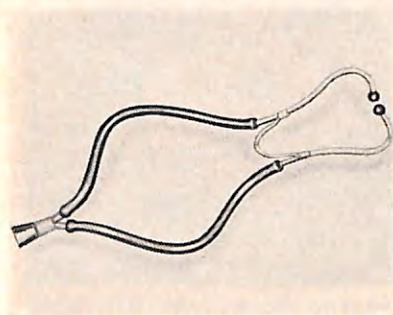

U. S. MEDICAL CORPS STETHOSCOPE. Anyone who's ever tried buying one of these will recognize this brand new U.S. Medical Corps Stethoscope as a real "find". Ideal for doctors, engineers and mechanics (to spot motor troubles, etc.), educational and fun for children and adults. Good value for \$2.95 ppd. Banner Supply, Dept. EK-2, 125 East 41st St., New York 17, N.Y.



SPLIT HEART KEY CHAINS for you and your "better half". Halves are hand-pierced and match-mated to fit only each other. First names and that special date are engraved on face of 1½-in. dia. heart. Set, in sterling silver, \$6; 12 kt. gold-filled, \$7; 14 kt. gold, \$50. Incl. engr., tax and post. 1 wk. air delivery. Wayne Silversmiths, 546E So. B'way., Yonkers, N.Y.

Merchandise shown on these pages can be ordered direct from the companies listed. Enclose a check or money order.



Handiest Thing in The House — \$1

Foam tape has adhesive backing that sticks to metal, glass, wood, fabric . . . cushions anything needing protection. A 1000 uses: prevents rugs from slipping, ashtrays or lampbases scratching, furniture from marking walls. Keeps pictures straight, dresses from slipping off hangers. Keeps blouse inside skirt band. Peel-as-you-go roll. 108" long, ½" wide. *Guaranteed to do the job or money back!* Only \$1, postage paid, 3 Rolls for \$2.79. Order CUSH TAPE from Sunset House, 415 Sunset Building, Beverly Hills, California.



Write For FREE STYLE BOOK

MORTON'S YOUR OLD FUR COAT INTO NEW CAPE, STOLE, JACKET \$22.95
MORTON'S remodels your old fur coat. Jacket or cape into glamorous new fashion for only \$22.95. Includes restyling, new lining, interlining, monogram, cleaning, glazing. ORDER FROM MORTON'S, WORLD'S LARGEST FUR RE-STYLING SPECIALIST. LARGEST STYLE SELECTION AT ANY PRICE. OVER 40 STYLES TO CHOOSE FROM. Praised by Harper's Bazaar, Glamour, others. Send no money! Just mail old fur, state dress size. Pay postman, plus postage, when new style arrives. Or write for Morton's new Style Book.
MORTON'S, DEPT. 45-B, WASHINGTON 4, D. C.

A GOLFING MUST!

TOURNAMENTS
SOUVENIRS
FIX BALL
MARKS
CLUB NAMES



ADVERTISE YOUR BUSINESS
Write for samples and prices

MARK-A-BALL

DEPT. EK • P. O. Box 5844 • PORTLAND 22, OREGON



Mrs. Douglas J. Baldwin
1926 Apple Valley Road
Rockland, Connecticut

500 PRINTED NAME & ADDRESS LABELS - 25¢

500 gummed economy labels printed in black with ANY name and address, 25¢ per set! In two-tone plastic gift box, 35¢ per set. 5-day service.

DE LUXE GOLD-STRIPED LABELS—500 for 50¢

Superior quality paper with rich-looking gold trim, printed with ANY name and address in black. Thoughtful, personal gift; perfect for your own use. Set of 500, 50¢. In two-tone plastic box, 60¢. 48-hour service.

2302 Drake Building
Colorado Springs 12, Colo.

Walter Drake

Personalized

DEN-SHUR-CUP

Protects Your Dentures!

Your dentures and bridgework can't stand scouring. Don't endanger precision fit or risk dropping when DEN-SHUR-CUP does your chore automatically!! Cleans valuable platework by normal soaking activation. Use any denture cleanser. This spillproof, watertight container is made of unbreakable plastic with hinged lid to fit any bridge or plate. Grand gift idea! Specify Name to Appear!



\$1.25 ea.
ppd.

Send check, cash or money order.

DEN-SHUR-CUP CO., Dept. H
30-92 Steinway St., L. I. C. 3, N. Y.



New Way to Sleep!

Tee-PJ's resemble a T-shirt, but are over a foot longer. Rib-Knit, soft combed cotton. Gives when you move, eases up when you relax. No bind, no bunch, no chafe, no buttons! If not most comfortable sleeper you've ever worn, return within 7 days for full refund and we send you regular T-shirt FREE!

S (34), M (36-38), L (40-42), XL (44-46, for weight over 180 lbs. and/or over 6 ft.)
\$2.25 ea. 3 for \$6

NOW! Tee-PJ's available in long sleeves with knit wristlets.
\$3.25 each 2 for \$6

All Postpaid
Available only by mail
WITTMANN TEXTILES
6787 Southshore Sta., Dept. 511
WEST PALM BEACH, FLORIDA



CANADIAN LANDS Seized and Sold for Taxes

\$151 buys 10 acres on good road
\$288 buys 25 acres near city
\$441 buys 80 acres on highway
\$589 buys 80 acres on river
\$643 buys 160 acres with buildings

Our 44th Annual Series of Lists, just begun, describe the above and many other choice properties acquired by us through Tax Sale. The amount quoted is the full price asked, guaranteed perfect title, no mortgage. Beautifully situated hunting and fishing camps, where there is real sport: summer cottage sites, heavily wooded acreages. Now is the time to invest in Canada's minerals, forests and farms. Write today for free booklet with full explanation.

TAX SALE SERVICE

Room 411-K, 1173 Bay St., Toronto 5, Canada

FREE! AIRMAILS



Fabulous collection of all-different genuine foreign Airmail Stamps from remote corners of the world — Africa, Europe, Exotic Orient, everywhere! World's Largest Airmail, Flying Doctor, Bomber, \$2.00 Helicopter, many others. PLUS Collection of thrilling Space-Age stamps — Sputniks, Jets, fantastic Moon Rocket stamps. Both of these remarkable collections — containing stamps worth up to 25c each! — for only 10c to cover mailing costs. Extra: Other sensational stamps for your free examination, plus Big Bargain Catalog. Rush 10c today to:
Jamestown Stamps Dept. F21EM, Jamestown, N.Y.

HERE'S AN EASY FAST WAY TO RAISE \$50.00 AND MORE



For Your Church or Group

Just imagine! Your group can raise all the money you need, easily, quickly, without 1c cost to you! I'll send your group a supply of my famous Special Grind Pure Black Pepper in advance. Have 10 members each sell only 10 cans at \$1.25 each; keep \$50 cash for your treasury, send me balance of proceeds.

Never Spend a Cent of Your Own Money!

Take up to 60 days; we give credit on Pepper. You risk nothing to try my amazing tested plan, used by over 50,000 groups.

FREE! Rush name, address for details of my Plan which brings you fast cash, or valuable equipment for your group...sent FREE, no obligation. Write TODAY to

ANNA ELIZABETH WADE, Dept. 200BB, Lynchburg, Va.

Guaranteed by Good Housekeeping

ARCO ROUTER-DRILL



SAWS • DRILLS • ROUTS • FILES
 Fits any Electric Drill. Cuts own starting hole and any shape in any direction tool is moved. Cuts plywood, lumber, formica, non-ferrous metals, thin sheet metal. Sharp milled cutting edges for long life. Send check, M.O.—postpaid. **\$1.39**
 Order today—20-day Money Back Guarantee.

ARCO ARROW METAL PRODUCTS CO.
 Dept. EL-2, 421 W. 203 St., N.Y. 34, N.Y.

FOR TALL MEN ONLY! SHIRTS WITH YOUR EXACT LONG SLEEVE LENGTH



PERFECT FIT IN your big size! Sleeve lengths to 38, neck sizes to 18½! Ivy League stripes, plaids, solid-tones, whites in Sport and Dress styles. New wash-and-wear fabrics! Bodies cut 4" longer than ordinary shirts! Not sold in stores — by mail only! We are America's best-known specialists for BIG MEN ONLY! Finest quality at sensible prices! Satisfaction Guaranteed! Write for FREE Catalog!

BIG FREE CATALOG!

Shoes, size 10AAA to 16EEE! Fine quality in smartest new dress styles. Also sport and work shoes, boots, socks, slippers. All FOR BIG MEN ONLY! A postcard brings you big color Catalog, FREE! Write today!

KING-SIZE, INC. 2581 BROCKTON, MASS.

ELKS



COCKTAILS WITH A FLAIR are at your fingertips with Twist-O lemon, a blend of choice lemon oils (not lemon juice). A gentle squeeze wafts a whiff into your drink... there's no peeling or clutter. Adds zest to cooking too. Handsome glass and brass container holds enough Twist-O for 2,800 drinks. \$4.95 ppd. Refills, \$1.95 ppd. Revord-James & Co., Dept. E, Golf, Ill.

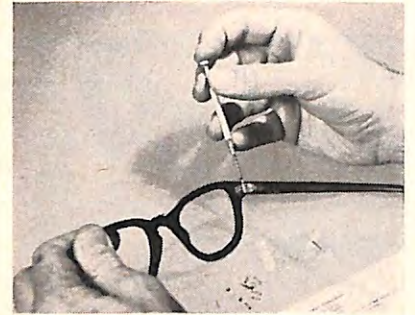

GLASSES REPAIR KIT prepares you for eyeglass emergencies. When the screws work loose from your frames, you can replace them from the supply provided in this kit, and use the tiny professional optical screwdriver to screw them in. Handy for watches, other small objects. \$1.00 ppd. Columbia Co., 404-E Security Bldg., 234 E. Colorado Blvd., Pasadena 56, Calif.



MEN FROM 17 TO 45... You can train as a Heavy Equipment Operator to be ready for tremendous financial opportunities in new construction throughout the country. If you are sincerely interested, a Northwest Schools representative will give you all the facts without obligation. Write (give age) to Northwest Schools, Dept. H-14, 730 Third Ave., New York 17, N.Y.



MAGNETIC HOOKS give you instant hangers for cups, tools, utensils, notes, potholders, pots and pans, etc. They stay put on anything metal... cabinets, stoves, refrigerators, cars. There are no holes to drill. Durable hooks remain as long as you need them and are easily removed. A set of 4 is \$1.00 ppd. Spencer Gifts, 614 Spencer Bldg., Atlantic City, N.J.

Merchandise shown on these pages can be ordered direct from the companies listed. Enclose a check or money order.

SHOE AWAY FOOT MISERY!

Helps healthy as well as "ACHING" FEET



NEW IMPORTED 'PEDI-MOLD' ARCH-SUPPORTING INSOLE

Your first step with Pedi-Mold will be your last step with fatigue and aching feet! Expertly modeled to the shape of the foot, Pedi-Mold is a masterpiece of design. Its exclusive construction adds spring to each step—for your toes move freely at last. Your circulation is increased and muscles strengthened. Now, bunion discomfort disappears—a direct result of Pedi-Mold's recessed ball area and metatarsals cushioned at pressure points. Flexible arch, clipped-out heel area give you maximum comfort and correct heel position. Made of soft foam rubber that won't flatten out, covered in leather.

\$3.00 pr.
2 for \$5.70 ppd.

PEDI-MOLD of New York

Dept. E-2, 505 5th Ave. (42nd St.) N. Y. 17, MU 2-7926



HURRY HOT POT—\$2.98

Electric Hot Pot boils a full 4 cups of water in only 2½ minutes! Perfect for making fast instant coffee, tea, soup, heating canned foods, baby's bottle. Practical pour-easy spout. Stay-cool base and handle let you use it right on the table. Made of polished aluminum... it's unbreakable. Complete with electric cord. Great for home, office, traveling, college. Tremendous value! You must be pleased or your money back! **HURRY HOT POT**, only \$2.98, postage paid. Order from **Sunset House, 415 Sunset Building, Beverly Hills, California.**

FAMILY SHOPPER



U. S. ARMY PARACHUTES have enough white nylon to make everything from car and dust covers to tents and clothing. These paratroop chutes are complete with some 600 ft. of 550-lb. test nylon cord shroud lines. They have 24 panels, are 72 ft. around, 24 ft. across. New surplus. \$10.95 (Add \$1.50 post.). Jackson Army, Dept. EK-2, 509 East 80th St., N.Y. 21.

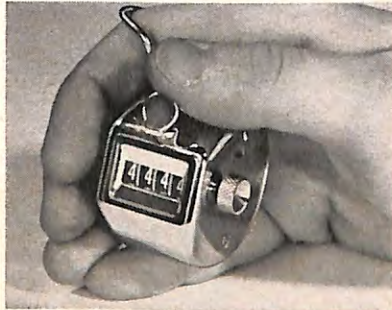

HAND TALLY COUNTER. Got something you want to count . . . laps in an auto race, people (or chickens) crossing the street, inventory, number of beers consumed? This precision counter fits in your hand, keeps an accurate total up to 9,999 and repeats. Side knob sets figures. Imported, chrome finish. \$4.95 ppd. K. D. McLean, Dept. EK-2, Box 991 Grand Central Sta., N.Y. 17.

Except for personalized items, there is a guaranteed refund on all merchandise returned in good condition within 7 days.



HISTORICAL POSTERS eloquently recall 19th century America. Each is hand printed in full color on antique vellum and has a wood-block or lithograph illustration. Incl. are "\$100,000 Reward for Murderer of Lincoln," "The Gold Rush," "Civil War Recruitment" (shown). Approx. 2 x 3 ft. \$3.00 ea.; 3 for \$8.00 ppd. Send for brochure. Flaghouse, Dept. E, 2010 Third Ave., N.Y. 29.



FOLDING BED BOARD is so lightweight and easy to handle, you can take it on your travels. It instantly firms up any mattress for healthful sleeping. New lightweight "aircel" construction. 5-foot length folds to four 15" sections. 30" wide twin size, \$5.96 ppd. (order 2 for double bed); 24" cot size, \$4.96 ppd. Better Sleep, Dept. E-2, New Providence, N.J.



If Your Child is a Poor Reader

See how The Sound Way to Easy Reading can help him to read and spell better in a few weeks. New home-tutoring course *drills* your child in phonics with records and cards. Easy to use. University tests and parents' reports show children gain up to *full year's grade* in reading skill in 6 weeks. Write for free illustrated folder and low price. Brenner-Davis Phonics, Dept. E-19, Wilmette, Ill.



Send for Free Style Book

YOUR OLD FUR COAT INTO NEW CAPE, STOLE. \$22.95* Tax Free

I. R. Fox, fur specialist, restyles your old, worn fur coat into a glamorous new cape or stole. Remodeling service includes cleaning, glazing, repairing, new lining, interlining, monogram. \$22.95 complete. (*mink, beaver, extras add'l.) Send no money! Just wrap up your old fur coat, mail it to us now. Send your dress size and height on postcard. Pay postman \$22.95 plus postage when new cape arrives. Or write for free style book. I. R. FOX, 146 W. 29th St., Dept. G-30, N. Y. 1



MAGIC BRAIN CALCULATOR - \$1

Pocket-size adding machine does all your math problems with ease. Adds - subtracts - multiplies to 99,999,999. MAGIC BRAIN CALCULATOR balances check books, adds grocery tapes, bridge scores, children's schoolwork, income tax statements, car mileage. Gives you the answer in seconds. Simple to use . . . all steel mechanism works fast. For housewives, professional men, businessmen, students. *Guaranteed to please or your money back!* MAGIC BRAIN CALCULATOR, only \$1, postage paid. **Sunset House, 415 Sunset Building, Beverly Hills, California.**

MEN! WE FIT W-I-D-E FEET!

E to EEEEE Only
Sizes 5 to 13

Men only. Casual, dress, work shoes that really fit. Top quality, popular prices. Money Back Guarantee.

Not sold in stores

Write Today for FREE CATALOG

HITCHCOCK SHOES, Hingham 11-A, Mass.

YOUR OLD COINS MAY BE WORTH A FORTUNE

You may have coins worth thousands of dollars in your pocket change, attic, piggy bank, around the house. **WE PAY OVER \$30,000.00 FOR CERTAIN RARE DATES.** Our catalog lists our prices and tells how to find valuable coins. For certain dates we pay up to: \$3,500 for Half Cents; \$4,800.00 for Large Pennies; \$600.00, Flying Eagle Pennies; \$2,000.00, Indian Pennies; \$250.00, Lincoln Pennies before 1932; \$1,500.00, Two-Cent Pieces; \$250.00, Three-Cent Pieces; \$16,000.00, Nickels before 1927; \$2,000.00, Half Dimes; \$4,750.00, Dimes before 1932; \$4,250.00, Twenty-Cent Pieces; \$4,500.00, Quarters before 1938; \$5,500.00, Half Dollars before 1939; \$11,750.00, Silver Dollars; up to \$35,000.00 for Gold coins, up to \$2,500.00 for Canadian coins. Only \$1 BRINGS our VALUABLE catalog. It may mean a FORTUNE to you. Catalog has information on U.S. paper money, Confederate paper money, tokens. We refund your \$1 when you sell us coins. **ABSOLUTELY GUARANTEED! SEND YOUR DOLLAR NOW!**

JAYMAR CORPORATION
Johnson City 86-A, N. Y.

15TH ANNIVERSARY SALE!

216 Different Stamps 25c

What a sale! Fantastic stamps from 15 years of imports. COLUMBIA - "Miss Universe." HUNGARY - Moon Rocket. SPAIN - Bullfight. MONACO - Lourdes diamond. U.N. - first stamp. FRANCE - Mystery Jet. You also get First Electronic stamp - with graphite on back. QUEMOY, ANTARCTICA, many others. Grand Total 216 different.

CIVIL WAR CENTENARY 1861-1961. Every stamp issued by the Confederacy. 14 fabulous authentic-looking facsimiles.

FREE! FREAK SET, 6 SE-TENANTS, 88 FLAGS OF THE WORLD, MIDGET STAMP ENCYCLOPEDIA. Entire "Anniversary Collection" - worth at least \$2.85 - ALL FOR 25¢ to introduce ZENITH's "Anything-You-Want" Bargain Approvals. **MONEY BACK GUARANTEE.**

SEND 25¢ TODAY. ASK FOR LOT FR-22

ZENITH CO. 81 Willoughby St., B'klyn 1, N. Y.

FREE! U.S. STAMPS
PLUS COMPLETE U. S. CATALOG



4 SENSATIONAL OFFERS IN ONE — ALL FREE
... to Introduce You to World's Largest Stamp Firm & America's Favorite Hobby

1. Genuine centennial postage stamp, as illustrated, picturing first U.S.A. (issued 114 years ago!)
2. Big collection of 25 all different United States — Ancient 19th century, \$1.00 stamp, etc.
3. Collection beautiful commemoratives: American Revolution, Wild West, 1893 Columbian, many others.
4. Collector's Guide; Big U.S. Bargain Catalog; exciting stamp offers for your FREE inspection. Send 10c for mailing. ACT NOW!

H. E. HARRIS & CO., DEPT. C-228. Boston 17, Mass.



MIZPAH COIN

Symbol uniting two people in love. Halves fit only each other. Coins face quotes Genesis, 31:49.

STERLING SILVER OR 12 Kt. GOLD-FILLED
1" dia. \$2.50 • 1 1/4" \$4 • 1 1/2" \$5
14 Kt. GOLD
1" \$25 • 1 1/4" \$35 • 1 1/2" \$50

Inscriptions on reverse at 10c per letter.
Write For Catalog Prices incl Tax And Ppd.

Wayne Silversmiths

546B South Bway. Yonkers 5, N. Y.

12 ODD JUNGLE BUTTERFLIES \$1

Tropical splendor to make stunning table and dresser tops, serving trays, waste baskets or framed. Vivid, colorful specimens up to 3" across are imported beauties, processed to lay flat — ready to mount. 12 all different postpaid just \$1 from

GREENLAND STUDIOS DEPT. EK-2
3735 N.W. 67 St. Miami 47, Florida



EASY WAY TO FILE CHECKS — \$1

CHECK-SAFE holds 800 cancelled checks, a 5-year record. Keeps them safe, clean — always in place for easy reference. Helps you budget. Keep a check on your personal spending habits. Cancelled checks are your best receipts — they act as important records. Essential for income tax purposes. Green Ripplette covered box, gold stamped. 7 1/4" x 5" x 3 1/4". Tab index dividers included. Satisfaction guaranteed or your money back! Only \$1, postage paid. Order CHECK-SAFE from Sunset House, 415 Sunset Building, Beverly Hills, California.

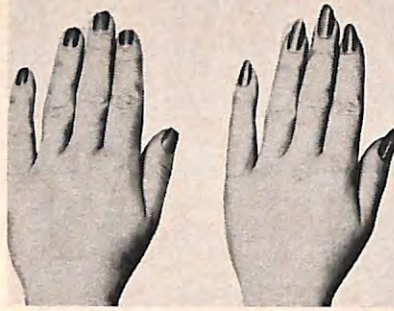

YOU CAN'T BITE your nails when you coat them with "Kant-Bite." One brushing of this completely safe scientific formula forms a diamond-hard coat that cannot be bitten. It also prevents annoying splitting, chipping and breaking of nails. At work or play, you'll keep your nails long and beautiful. \$1.50 ppd. Kant-Bite Co., Dept. E-3, Box 75, Rugby Sta., Brooklyn 3, N.Y.

BIG MEN'S SPECIAL!



HOODED SWEATSHIRT

Sensational once-in-a-lifetime offer from B. R. PAGE — the nation's leading specialist in apparel for Tall Men (38-54) and Big Men (44-66)! Top quality hooded sweatshirt has new "pivot action" sleeves, front pouch pocket. Order maroon, gray, blue. ONLY \$3.98 ppd.!

FREE CATALOG

Latest edition of famous B. R. PAGE catalog. Complete assortment of extra-large size apparel. Satisfaction GUARANTEED. Easy budget terms.

B. R. PAGE CO. DEPT. 180 272 Centre St., Newton 58, Mass.

Please remember to print your name and address clearly on your order and include zone numbers for faster delivery.



Amazing New Royal-T WALLPAPER REMOVER

No expensive steaming
No tiresome scraping

Wallpaper practically falls off in your hand when you remove it with Royal-T WALLPAPER REMOVER. Simply mix 2 ozs. of this wonder-working liquid concentrate in a gallon of water and apply to paper with rag, brush, sponge or spray. WALLPAPER REMOVER penetrates paper, loosens adhesive, and paper "skins off" smoothly in a matter of minutes. Works miraculously on several layers of paper and even on troublesome painted-over wallpaper. As safe to use as water. Only 98c plus 25c handling and postage for 6 oz. bottle, enough for walls and ceiling of one average room. ECONOMY SIZE: enough for about 3 rooms, \$2.49 postpaid. Results guaranteed or money back. Send cash, check or money order to:

ROYAL-T PRODUCTS
Dept. EK-21K, • 811 Wyandotte, • Kansas City, Mo.



ELKS

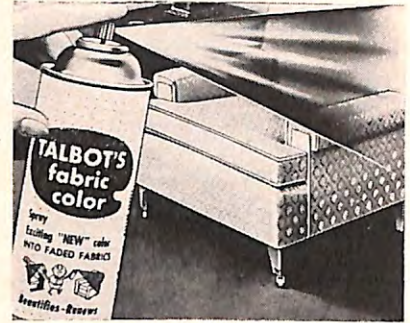

NEW COLOR FOR OLD FABRICS. Aerosol Spray puts color brightness into faded throw rugs, drapes, upholstered furniture, lampshades, etc. It's fast-drying, easy-to-use. In chocolate brown, royal blue, grey, forest green, persimmon, burgundy, black, bright red, turquoise. 1.5 oz. can, \$2.99 ppd. Nancy Ellen, 614 Spencer Bldg., Atlantic City, N.J.



OLD TIMER . . . new version. This Grandfather's Clock stands just 8" tall and keeps perfect time. It has gleaming brass weights, a pendulum and even a secret compartment for winding key. Mailed to your order from Europe. Choice of ivory, blue or red. Only \$2.98 plus 50c postage and handling. Murray Hill House, Dept. E, P.O. Box 126, Bethpage, N.Y.



SEA SHELLS FROM THE SEASHORE plus a little imagination transform ash trays, photo frames, plant holders, lamps into colorful originals. 50 authentic deep sea treasures include sea horse, starfish, cockles, calico clams, "whispering" echo shells, lacy coral, in assorted sizes and colors, for \$1.00 ppd. Greenland Studios, Dept. EK, 3735 N.W. 67 St., Miami 47, Fla.

FAMILY SHOPPER



ANYONE CAN DRAW . . . when he uses the Magic Art Reproducer. Just focus it on any subject and follow the lines of the "picture image" reflected on the paper. You'll be able to draw humans, animals, still life, landscapes. The Reproducer shows actual colors and reduces or enlarges the subject. \$1.98 ppd. Norton Products, Dept. EL-21, 296 Broadway, New York 7, N.Y.



JIFFY JUMP-IN SUIT lets you putter in style. A full length zipper and drop-seat back make it a jump-in joy. Pert bow ties at the waist. Fine Lowenstein heavy satiny suit is available in black or blue trimmed with red and white; or tan trimmed with coral and toast. Sizes 12 to 20. \$6.95 plus 50¢ post. Old Pueblo Traders, Dept. ELJ, Box 4035, Tucson, Ariz.



GIANT PLASTIC SHEETS. You can use these 9 x 12 foot Sheets to protect furniture, air conditioners, carpets . . . or make them into tablecloths, aprons, appliance covers, etc. Strong durable transparent plastic is waterproof, resistant to dirt and grease. 2 for only \$1.10 ppd. Barclay Distributors, Dept. E, 170-30 Jamaica Ave., Jamaica, N.Y.

LIVING FENCE



*Fast-Growing
Ever-Blooming
Amazing* **RED ROSE HEDGE**

FOR AS LITTLE AS 12¢ A FOOT

See the sensational Red Robin Rose Hedge (*Gloire Des Rosomanes*) that's sweeping the country! Plant **THIS SPRING**; have a vigorous **LIVING FENCE** bursting with fragrant **RED ROSES** this summer. Red Robin's lush green foliage is covered with a riot of richly scented red roses month after month. Not a sprawling Multiflora. Grows straight, upright to 6 feet, stays compact. So tough, thrives in even poor soils. Grows so dense Red Robin keeps children and pets in, animals and intruders out. Available only from Ginden Nursery, San Bruno, Calif.

RECOMMENDED BY THE NATIONAL GUARANTEED BY Good Housekeeping



YOURS FREE!

FULL COLOR BOOK fast landscape ideas with Red Robin Living Fence!



Ginden Nursery Co.
Dept. 311 San Bruno, Calif.
Send me without cost or obligation, free full-color book, uses, prices, references, bonus offers, etc., on **RED ROBIN LIVING FENCE**

NAME _____
ADDRESS _____
CITY _____

POLE HOLD

DON'T Use Old-Fashioned, Awkward Harness Devices

The new **POLE HOLD** gives you an immediate assist in landing even the biggest ones—as it remains affixed to your rod all the time you are fishing. Can be attached or removed in a second. Made with Butyl rubber to resist aging and corrosion. No tackle box is complete without a **POLE HOLD**. Send \$2.95 (ppd) in check or M.O. to:

FISH-EZE PRODUCTS, INC. Dept. J2
7825 Melrose Ave., Los Angeles 46, Calif.

Only **TWO \$5.00** Jobs a Day at Home

PAYS \$240.00 A MONTH!

BEFORE **INVISIBLE MENDING**

Makes Cuts, Tears, Holes DISAPPEAR from Suits, Coats, Dresses — ALL FABRICS!

AFTER

Invisible Menders (Reweavers) who do only two \$5 jobs a day can earn \$240 a month. And a \$5 job can be done at home in about ½ hour by an expert Fabricon Mender. In many communities invisible menders are scarce; service is expensive—often unavailable. Can you learn to do this fascinating, profitable work? Can you earn \$240 monthly in your community? We'll tell you what it takes to learn invisible mending; we'll tell you what to do to check the opportunity for profit in your town. Get the answers to these questions free . . . and complete information . . . all free! Write for details!

FABRICON CO., 6238 Broadway, Dept. 752, Chicago 40, Ill.

50 REFILLS for \$1

Double shot, fits all standard pens. Red, Blue, Black or Green ink.

BRASS REFILLS \$4.24 for \$1

Triple shot silver tipped, fits all pens including "Scripto", "Weaver", "Paper Mate", and over 200 others (except Parkers). Red, blue, black or green ink.

SPECIAL COLOR REFILL 12 for \$1
Yellow, Gold, Lavender, Aqua, Pink, Brown.

TOP ACTION PENS \$3 value 20 for \$1

Choice of red, blue, black or green. Add 10¢ shipping charge. Money back guar. Quantity and imprint prices on request.

GIANT PLASTIC TARP Now Only 43¢

Formerly \$1.25 Each

Huge 9' x 12' size covers and protects cars, furniture, carpets, etc. Or make into tablecloths, apron, covers, auto seat covers, etc. Waterproof, durable, transparent. No seams. Min. order 2 tarps at 43¢ ea. Add 24¢ post. Total \$1.10. Money back guarantee.

Exclusive 2-Way Hood or Hat HEAVY KNIT STORM HOOD \$1

Anyone who goes outdoors when it's cold and damp, needs this sensational new design . . . wear it as a hood or a hat. As a wonderfully warm hood, it protects your head, mouth, neck and ears, keeps out cutting wind and biting cold. Available only by mail; fits men, women, children. Add 20¢ postage and handling. Money back guarantee.

FREE! \$1 Gift Certificate with your order. Apply it on any \$5.50 purchase from **FREE CATALOG** we send you. One to a family.

BARCLAY DISTRIBUTORS, Dept. 51-B
170-30 Jamaica Avenue, Jamaica, N.Y.

BUY REAL DIAMONDS THIS NEW WAY SAVE 1/3 TO 1/2!



1 Carat Brilliant White Diamond Lady's or Man's Solitaire Ring
\$395.

The talk of the Country—You can now buy diamond jewelry by mail direct from one of America's Well Known Diamond Cutters. Any ring mailed direct for **FREE 10 DAYS** inspection without any payment, if references given. Even appraise it at our risk. Send for free catalog.

Over 5000 styles \$50. to \$100,000.

EMPIRE DIAMOND CORPORATION
Empire State Building, New York 1, New York

Send **FREE** Catalog 27X

Name _____
Address _____
City _____ State _____

Guardians of Freedom: the Elks and the Press

THE DIFFICULTY of selecting this year's best National Newspaper Week observances from among the many reports sent in by the lodges of Elksdom can be seen from the fact that there was a tie for third place among lodges with less than 700 members—and Honorable Mention was won by no less than seven lodges in each category (those with a larger membership, and those with fewer than 700).

This is a tribute to the Order's understanding of the importance that freedom of the press has in maintaining our democratic way of life.

Chairman Nelson E. W. Stuart of the Grand Lodge Committee on Lodge Activities reports that among lodges with 700 or more members, first, second and third place went, respectively, to Phoenix, Ariz.; Woonsocket, R. I. and Scranton, Pa. Honorable Mention went to Belleville, Ill.; Dowagiac, Mich.; Gallup, N. M.; New Philadelphia, Ohio; Roanoke, Va.; Wheeling, W. Va., and Worcester, Mass. First, second and third place lodges with fewer than 700 members were Fulton, N. Y.; Logan, W. Va.; and, in the previously mentioned tie, Southampton, N. Y., and Bethlehem, Pa. Those receiving Honorable Mention were Anderson, Ind.; Oelwein, Iowa; Paducah, Ky.; Parma, Ohio; Pascagoula, Miss.; Portland, Maine, and Tuscaloosa, Ala.

Phoenix Exalted Ruler T. W. Jessup and Secretary L. C. Gavagan estimate that the lodge's Newspaper Week Committee, headed by Sherman Payne, spent at least 175 man-hours to prepare a successful observance. A resolution of confidence in the integrity and service of local newspapers, issued by the lodge, carried this quotation from the Bible (John, 8:32): "The truth shall make you free." Newspaper Week proclamations were read by Governor Paul Fannin and Mayor Sam Mardian, but perhaps the highlight of the observance was the fifth annual presentation of a Plaque for Outstanding Public Service to a local member of the press. This year the award went to Publisher W. B. Wright of the Phoenix Sunpapers, "in appreciation of the comprehensive coverage of worthy community events by his newspaper, underscoring the fact that enlightened newspapers are truly freedom's guardian."

Coverage of the Woonsocket, R. I., observance was obtained in the *Woonsocket Call*, *Providence Journal*, and radio stations WWON and WNRI; representatives of both the papers and ra-

dio were also present at the ceremonies and party given in recognition of the press, reports Program Chairman Armand Comeau. At these ceremonies, Exalted Ruler G. J. Gaulin presented government bonds and cash awards to outstanding local newspaper boys. These news carriers were chosen on the basis of their conduct in school, church, civic and other activities, and their method of newspaper delivery. Guest speaker on award night was Manager Zel Levin of Radio Station WWON. A highlight of the observance was the publication of *The Junior Call* to mark Newspaper Boy Day. This was a special edition of the *Woonsocket Call*.

Colonel S. A. Grogan (ret.) is assistant to the director of the Central Intelligence Agency in Washington, and is a former Scranton, Pa., newspaper man. At Scranton Lodge's Newspaper Week dinner he was an extremely interesting guest speaker, outlining C.I.A.'s history and its present role in the government's efforts to maintain freedom and to combat such aggressive forces as communism. Program Chairman J. I. Myers also obtained the services as guest speaker of T. L. Moran, general manager of *The Scranton Times*, who pointed out that newspapers, as representatives and reporters to the people, guard our political freedom by demanding—and doing everything in their power to preserve—government that serves those people. Exalted Ruler I. E. Cunningham, Jr., also addressed the gathering, and entertainment was provided by the Elks Quartet.

Eight Newspaper Week projects helped to bring Fulton, N. Y., in first among lodges with fewer than 700 members. Those projects included paid ads in the five area papers congratulating the press; a student essay contest on the theme "Your newspaper—Freedom's Guardian"; a student poster contest on the same theme; a favorite newsboy contest; a tour of newspaper plants for students interested in journalism; an exhibit of newspapers over 100 years old, set up in the lodge lobby; a cocktail party for newsmen and their wives; and the Sixth Annual Newspaper Dinner for Fulton newsmen, with State Editor James Doyle of the *Utica Observer Dispatch* as principal speaker. Mr. Doyle is a Past District Deputy. Newspaper Week Chairman R. J. Quade reports that well over 100 attended the cocktail party, and more than 135 were present at the dinner.

In order to find the Logan, W. Va.,

community's favorite newsboy, Logan Elks held a letter-writing contest among subscribers to the local paper, the *Logan Banner*. Entrants were invited to write to the *Banner*, telling why they favored a particular boy. The winning letter writer, Mrs. Ernest Huffman, was awarded a handsome pen and pencil set; the winning newsboy, eighth-grader Dwain Barker, received a savings bond. It is gratifying to note that young Dwain is saving his paper route earnings to help meet college expenses. Another presentation should also be reported here: Managing Editor Charles Hylton and General Manager R. O. Greever accepted a plaque on behalf of the *Banner* from Exalted Ruler A. S. Ammar. Program Chairman P. W. Murphy explains that this was in appreciation of the fine cooperation rendered in publicizing Elk activities.

Program committeemen of Bethlehem, Pa., Lodge, headed by T. J. Hudak, invited the editors of six local high school papers—representing the "future editors of America"—to their observance, together with the staff of the *Bethlehem Globe Times*. This newspaper was honored by the lodge as the State's finest paper in its circulation category. *Globe Times* Editor John Strohmeier, guest speaker at a dinner given by the lodge, stressed future opportunities for today's youth in the field of journalism.

The Elks of Southampton, N. Y., emphasized two main objectives in this year's observance: The first was to seek strong public participation, particularly in the schools; the second was to underline at the banquet the activities of newspaper people in specific areas of civic work. Following through on the first objective, the staff of the *Bridgette*, published by Bridgehampton High School, arranged an exhibit of front pages from some fifty newspapers of long ago, plus a display of overseas publications. Guest speaker at the dinner (which received publicity in all the area papers) was Stuart Gracey, former publisher of *The Port Jefferson Record* and a widely known civic leader.

Presiding over the observance were Exalted Ruler J. H. Zentgraf, Secretary H. M. Hallock and Dinner Chairman C. J. Videla.

Though space does not permit a full account of Newspaper Week activities throughout Elksdom, this account of winning programs should show the enthusiasm of the Order in saluting America's free press. • •

Newspaper Week observances throughout the Order honor the press, a safeguard of liberty



Exalted Ruler William Prashaw of Fulton, N.Y., Lodge proudly presents two young people honored during Newspaper Week Ceremonies: essay contest winner Kenneth Abbott and poster contest winner Ann Cali.



Newspaper boys of Woonsocket, R.I., pause in their partaking of refreshments to have their picture taken with program chairman Armand Comeau. These outstanding boys were chosen on the basis of conduct, not only in paper delivery but in school, church, civic and other activities.



The favorite newsboy of Logan, W.Va., was chosen by newspaper subscribers, who participated in a letter-writing contest to nominate their choice. Pictured here is the winning letter writer, Mrs. Ernest Huffman, as she receives the award of a pen and pencil set from Past Exalted Ruler P. W. Murphy. Her letter led to the choice of eighth-grader Dwain Barker as favorite newsboy.



Newspaper publisher W. B. Wright and his "partner," Mrs. Wright, proudly display the Plaque for Outstanding Public Service presented to Mr. Wright by Master of Ceremonies Charles Pine on behalf of Phoenix Elks. Mr. Wright, publisher of the Phoenix Sunpapers, received his plaque in the fifth annual presentation of the awards by Phoenix Lodge.

B. P. O. E. PARTY FAVORS



On party nights favor your ladies with a selection of beautiful Elks emblem gifts. Distinctively designed Bowknot pin is set with luxuriously brilliant rhinestones in goldtone or rhodium. Enameled B.P.O.E. Emblem pendant. Safety catch pin fastener...\$1.45²

And when planning a party you'll want emblem decorations, napkins, doilies, place mats, cards, etc. Prices F.O.B. Chicago *plus F.E.T.

Write for complete selection

RH RUSSELL-HAMPTON CO.
303 W. Monroe St., Chicago 6

YOUR OWN SHOPPER

Thousands of Elk families have learned the convenience and pleasure of shopping by mail through their ELKS FAMILY SHOPPER. Right now, why don't you turn to this month's SHOPPER pages and see all the interesting, attractive and useful items offered—all under the guarantee of a refund if you are not satisfied with your purchase.

PART TIME INCOME!



Sell Advertising Matchbooks to Businesses in Your Area! Fast, easy "order from the catalog" selling, with big cash commissions and steady repeat orders. Free sales kit shows you where and how to get orders. Part or full time. No experience needed. No investment, no risk. Every business a prospect! Write today for details!

MATCH CORPORATION OF AMERICA
Dept. MR-21, 3433-43 W. 48th Place, Chicago 32, Ill.



STOP GRAY HAIR Look 10 yrs. Younger

Amazing "FLORAL HERB" Hair Treatment and Color Restorer. Not a dye. Not a tint. Restores natural looking hair color, relieves itching scalp and dandruff. Imparts new gloss and sheen. Keeps hair soft, healthy and well groomed. Won't stain or rub off. No dyed look. Works gradually. Send only \$2.00 for large 8 oz. bottle postpaid. Satisfaction Guaranteed.

TROPICANA, Dept. EK
P. O. Box 305 Clinton, Indiana

MY SPARE TIME HOBBY MAKES ME

**\$500 an hour
CASH PROFIT**

— Grover Squires



START YOUR OWN SPARE TIME BUSINESS
You can turn your spare time into Big Cash Profits with your own COMPLETE SHARPENING SHOP. Grind saws, knives, scissors, skates, lawn mower blades... all cutting edges. Your Own Cash Business with no inventory right at home... no experience needed. FREE BOOK tells how you can start your own spare time business while you are still working at your regular job. Low Cost—time payments only \$15.00 a month. Send postcard today.
BELSAW SHARP-ALL CO., 7261 Field Bldg., Kansas City 11, Mo.

Get Yourself **FIXED** for LIFE

with the **ONE** shoe line that serves Everyone from Baby to Pop & Mom

Success opportunity! Sell America's biggest and most comfortable line of shoes for all the family. It's no trick at all to make big money FULL or SPARE TIME with over 240 popular patterns to show eager buyers. Big money daily plus cash bonus. No experience necessary. I show you how. Send today for free "Portable Shoe store".

ORTHO-VENT SHOE CO.
2512 Brand Rd., Salem, Va.



I Give Producers Their Own Shoes As a Bonus!

For Elks Who Travel

(Continued from page 17)

Greek word *eleutheria*, for freedom. Pineapples were once raised here and shipped to Britain, but the incoming Hawaiian crops ruined the market and now Eluthera lives on tomatoes and tourists. It also raises chickens, and some dilettantes are trying their hand at cattle.

Craig Kelly, one-time stage and television actor, has a place called French Leave, close to Governor's Harbor, which borders on a great pink sand beach. Besides the clear ocean, there is a pool shaded by all sorts of drooping foliage. Horses for hire, dancing at night, and an ample bar cooled by

spinning ceiling fans, just like W. S. Maugham.

Then, up island there is the Rock Sound Club, very manicured and rather proper, but beautiful all the same. Farther on, the Cotton Bay Club, a beautiful golf course and cottage colony, has at last decided not to take public guests, but there are dozens upon dozens of handsome dens in the rest of the out islands, and anyone interested in searching out a hideaway where it's warm might well direct a query to the Nassau Development Board in the Bahamas. You never know what type of a plush pad you might turn up.



THE ELKS MAGAZINE TRAVEL DEPARTMENT

THIS is the 350th anniversary of the King James Bible. If you're planning a trip to New York for the Easter holiday, consider a visit to the American Bible Society's headquarters, Bible House, Park Avenue and 57th Street, to see one of the world's most unusual libraries. The Society has a collection of the Scriptures in over 1,100 languages and dialects, plus many other rare and priceless Bibles dating back to the 15th Century. Observance of the anniversary will begin February 15th and will continue throughout Lent, with a display of unusual Bibles.

For all you winter sports fans, good news. The 1960-61 directory of winter sports areas in all parts of the Badger state has just been released. Entitled "Winter Fun in Wonderful Wisconsin", it contains information on what Wisconsin's 43 ski centers offer and whom to contact for details and accommodations at each. Copies of the directory may be obtained by writing Recreational Publicity Section, Wisconsin Conservation Department, Box 450, Madison 1, Wisconsin.

Travelers touring Italy this year should keep in mind a new service of the Italian Touring Club. In case an emer-

gency arises, messages for tourists enroute will be broadcast in English, French and German from 8 to 8:50 a.m. daily on the program "Benvenuto in Italia" (Welcome to Italy). Any emergency messages should be forwarded directly to the Italian Touring Club, which will make arrangements for airing them.

A *Shikar* is India's answer for big game hunters seeking something different in sporting adventure. A princely caravan threading its way through the jungle in search of tigers, with scores of servants and chefs to tend every need, expert hunters to guide, adventure just beyond each rustling leaf—that's *Shikar*! Tempted to try the sport of Maharaajahs? Contact the India Tourist Office for information and names of qualified agents who can handle the details.

For the distaff traveler, Air France is offering, at no charge, three useful booklets chock-full of travel pointers. The titles: "Very Important Pointers for International Travel", "VIP Currency Converter" and "VIP Shopping in Paris". Write Collette D'Orsay, Air France, 683 Fifth Ave., New York 22.

Planning to visit the Caribbean this season? If so, don't miss seeing a "moon-bow". These are night-time rainbows created under certain atmospheric conditions common along the sheltered leeward coast of the island of Aruba, Netherlands West Indies. The Aruba Caribbean Hotel-Casino offers a moonlight cruise aboard the yacht *Sea Queen* to take in the exotic sight, along with a two-hour stop for an authentic Dutch-Indonesian "ricetafel". Cost per person is just \$14.

If you happen to be in the vicinity of New Orleans on Mardi Gras Day, February 14th, don't miss the parade that day. The Elks Krewe of Orleanians, Lodge No. 30, will be marching.

LETTERS FROM OUR READERS

I am planning a make-believe trip to Berlin, Germany. I am doing this for a school assignment. I am in the seventh grade.

I need information on the cost by air, food, expenses, points of interest in Berlin, hotel expenses and an estimate on the number of miles from Spokane, Washington.

If THE ELKS MAGAZINE Travel Department could please also send me information on several other places in Europe, which might be available, I would appreciate it.
ST. MARIES, IDAHO DEAN WEBB

The Travel Department is very glad to comply with this request, and has sent the available information to Dean Webb. The Editors would like to add that they wish Dean an extremely enjoyable make-believe trip. Bon Voyage!

The "Rod and Gun" articles in THE ELKS MAGAZINE are always very interesting to me, as I was the first Chairman of the Washington State Game Commission and was a member thereof for twelve years—1933 through 1945. I am in my 78th year, and in perfect health, which I attribute to my outdoor hobbies and the art of walking.

What prompted this letter was Dan Holland's "The Reel Story" (a history of the Meek bait casting reel) in the December issue. I inherited a Meek reel from my father, who used it screwed onto a long cane or bamboo pole. It still appears to be in perfect shape.
SPOKANE, WASH. T. A. E. LALLY

I have been reading the Magazine's articles about hunting and fishing ever

since they first started appearing, and have always enjoyed them. We have hard-to-get-at but good hunting in this part of the world.

SAO PAULO, BRAZIL L. A. WEISENBARGER

I liked John R. Crawford's article about cards in the September issue of the Magazine very much. I, for one, enjoy simple explanations of rules, such as Mr. Crawford uses. May success crown his efforts.

OCALEA, FLA. MRS. EARL FUTCH, JR.

The articles about card games, by John R. Crawford, are very interesting to me and to others with whom I've discussed them.

SAN FRANCISCO, CALIF. STEWART JAMES

I read the "Play Cards with John R. Crawford" article in the December issue—the one about gin rummy—and was very much pleased by it. I would like to compliment the author for doing such a good job.

LAWRENCE, MASS. W. H. CURRIER

The articles by John R. Crawford are very lucid and get to the matter very clearly. Not only do I enjoy them a great deal, but I save them. Does Mr. Crawford have a book available on various card games?

DECATUR, ILL. O. L. CRANE

Mr. Crawford's book "How to Be a Consistent Winner in Ten Most Popular Card Games" is available from Doubleday Books, Order Department, 655 Fifth Avenue, New York City. The price is \$2.95.

William O'Brien



Hartford, Conn., Lodge, No. 19, and all of New England, mourn the passing of William O'Brien, the Order's most venerable member.

William O'Brien passed away just a month after he had celebrated his 75th anniversary as a member of Hartford Lodge, and just five months short of his 100th birthday, May 18th.

Devoted to Elkdome and to its ideals and principles, Bill O'Brien attended his lodge regularly and frequently, enjoying excellent health almost until his death. He had been most active in his lodge all during his long affiliation, and while he had never held office, he had served on almost all of his lodge's committees.

William O'Brien was well known in Hartford, having lived there all his life and having been most successful in business there over a long period of years. He is survived by his sister.



LAW TRAINING FOR BUSINESS

(In spare time at home)
Earn LL. B. Degree

Thousands of men and women who never intend to practice Law are studying it in spare time at home as an aid to business advancement.

Today Law is involved in practically every business decision. In many lines of work it is almost indispensable. Law training develops keen, clear, quick, correct and decisive thinking.

You can study LaSalle's American Law and Procedure right in the privacy of your own home—progressing as rapidly as your time and ability permit. For more than 50 years we have helped over 1,400,000 ambitious people get ahead in the business world.

A MOST UNUSUAL LAW LIBRARY

This training includes the 14-volume LaSalle Law Library—AMERICAN LAW AND PROCEDURE—that is the basis of all our instruction service. This library has been compiled by leaders in the field of Law. It covers the whole field in an orderly and simple manner that is easy to learn and understand. Collateral reading and printed lectures, furnished at regular intervals, supplement the texts. Law instructors personally supervise your program. Under the LaSalle method you learn by actually solving legal problems—not just memorizing rules.

WRITE FOR TWO FREE BOOKS

Send the coupon below TODAY and find out how you can qualify for the many fine openings available to the law-trained man. In our FREE books "Law Training for Leadership" and "Evidence" you will find answers to your questions about the study of Law and the LaSalle method.

Accredited Member, National Home Study Council

MAIL COUPON TODAY

LA SALLE EXTENSION UNIVERSITY
A Correspondence Institution

417 S. Dearborn Street, Dept. 2328L, Chicago 5, Ill.
Please send me, FREE, "Law Training for Leadership" and "Evidence."

Name.....Age....

Address.....

City.....Zone....State.....



ST. LOUIS, Missouri, Lodge's 11th Annual Sports Celebrity Dinner found these men playing stellar roles. At left is Bob Cochran, top-flight golfer who was named the "Outstanding St. Louis Sports Figure" for 1960; at right is Robert F. Hyland, Manager of radio station KMOX and Vice-Pres. of the Columbia Broadcasting System, who was the recipient of the Bruce A. Campbell Memorial Award given for outstanding service to sports by a non-participant. Congratulating both is E.R. John C. Ross.

WITH COLORFUL JOE GARAGIOLA again serving as Master of Ceremonies, St. Louis, Mo., Lodge, No. 9, conducted its 11th annual Sports Celebrity Dinner at the Hotel Chase on November 10th. The lodge's Shoe Fund, which provides footwear for underprivileged children, received a substantial sum from this affair, as well as an outright donation of 396 pairs of shoes from the Brown Shoe Company.

Pete Rozelle, new commissioner of the National Football League, delivered the principal address, and the trophy awarded to the "Outstanding St. Louis Sports Figure for 1960" was presented to Bob Cochran, St. Louis golfing finalist in the British and Western Amateur Tournaments. The award was made by Bob Burnes, sports editor for the *St. Louis Globe-Democrat*.

The Bruce A. Campbell Memorial Award for outstanding service toward sports by a nonparticipant in athletics, went to Robert F. Hyland, General Manager of radio station KMOX and Vice-President of the Columbia Broadcasting System. This presentation was made by the *Globe-Democrat's* publisher, Richard H. Amberg.

Presiding at this fine program was Exalted Ruler John Ross. Tony Pinter was Chairman of the sixteen-man Committee in charge.

Special plaques were awarded by the lodge for the year's top figures in individual sports as follows: Baseball, Stan

Musial of the Cardinals; Basketball, Coach John Benington of St. Louis University; Bowling, Don Carter of the Budweiser team; Boxing, referee Harry Kessler; Football, Danny LaRose of the University of Missouri eleven; Golf, Bob Cochran; Handball, Dr. Stan London; Soccer, Bob Guelker of St. Louis University; Tennis, Earl Buchholz, Jr., of the U. S. Davis Cup team, and Wrestling, Coach John Moore of Ritenour High School.

Players, coaches and representatives of the St. Louis baseball and football Cardinals, the basketball Hawks, St. Louis, Washington and Missouri University teams, and all other branches of sports were introduced.

THE THREE-POINT PROGRAM of action asked for by Grand Exalted Ruler John E. Fenton was outlined by its creator during the Midwinter Meeting of the Iowa Elks Association at Waterloo. Over 300 Elks attended the two-day session, including Past Grand Exalted Ruler H. L. Blackledge and Grand Treasurer Arthur M. Umlandt. President John McKeever, Secretary Sanford Schmalz, Chaplain Rt. Rev. Msgr. Edward V. Vollmer and Treasurer A. P. Lee were the State Association officials welcomed by Exalted Ruler Jack Fox, along with 12 Past Presidents and representatives of 36 lodges who saw Decorah Lodge take the Ritualistic Title.

Judge Fenton congratulated the Iowa

Spotlight on Sports and St. Louis

Elks on their recent contribution of \$15,000 to the State camp for crippled children. In connection with his three-point program, the Grand Exalted Ruler called attention to Fort Dodge Lodge's 223 new Elks during the past year, spoke of the institution of new lodges and emphasized the importance of the Elks National Foundation for which Iowa's goal is set at \$30,000 for the year.

The meeting concluded with a smorgasbord and dance.

FORMAL CEREMONIES marked the dedication of the home of Petaluma, Calif., Lodge, No. 901, with 500 Elks and their ladies in attendance. The lodge recently acquired the Hotel Petaluma building and remodeled the main floor to meet lodge requirements; the upper four stories are leased to a hotel operator.

Past District Deputy Emmett S. Dado served as Master of Ceremonies, introducing the speakers who included such dignitaries as Past Grand Exalted Ruler L. A. Lewis, State President Guy A. Daniels and Past President Charles T. Reynolds, District Deputy Robert E. Rich, State Trustee August Lepori, Mayor Arthur W. Parent and Exalted Ruler A. R. Elder who, incidentally, is serving in that office for the second time; his first term was in 1932-33. Mr. Rich, assisted by a corps of Past District Deputies, handled the dedication.

HIGHLIGHT OF THE FALL season in East Liverpool, Ohio, sports circles was the affair put on by the members of the local Elks Lodge No. 258 as a tribute to Bernie Allen. The testimonial honored one of the city's outstanding athletes and was one of the biggest sports attractions since a similar Elk

program honored Tom Jenkins, former Pittsburgh star, in 1957.

Allen, voted the most valuable player on the Purdue squad and an All-American this season, was lauded by his backfield coach, Bob DeMoss as "one of the greatest". DeMoss was introduced by Red Donley, sports director of WSTV-TV. Over 350 persons turned out for this event, among them Mayor Bert Goodballet, who is an active member of the host lodge.

Exalted Ruler John L. Rippeth delivered the welcoming address and movies of the Ohio State-Purdue game were narrated by DeMoss. Guests included members of the local high school eleven and their coaches, gridiron players from various colleges who were home on vacation and East Liverpool's 1957 triumphant Tom Jenkins.

The program was handled by an efficient committee under the leadership of James Welch.

JONESBORO LODGE NO. 496 was the recipient of the only State award made during the three-day Fall Meeting of the Arkansas Elks Association in that city. It was presented to Youth Activities Chairman R. E. Johnson in recognition of his lodge's outstanding youth program.

Dr. Ben Saltzman of Mountain Home, principal speaker at this session, succeeds Boland Phillips of Texarkana as President of the State group; Mr. Phillips was elected to a five-year term on the Board of Trustees, serving with James H. Webb, Hot Springs; Maurice Finn, North Little Rock; J. I. Melham, Brinkley, and Victor Wilder, North Little Rock. Vice-Presidents are H. W. Martin, North Little Rock, and James M. Vaughn, Hot Springs. Sam Milazzo of Texarkana Lodge is Treasurer and Robert Acheson of Mountain Home Lodge is Secretary.

Other dignitaries on hand at this session were former Grand Lodge Committeeman Charles Lilly and District Deputy L. E. Burrell.

E. A. WILLIAMS, President of the North Carolina Elks Assn., opened a three-day meeting of that group at Goldsboro and called upon all of us to "rededicate ourselves to the principles upon which our country was founded", asking all civic and fraternal organizations to recognize and understand the threat to our way of life.

At Memorial Services Mayor Scott B. Berkley paid tribute to members of the State group who had died during the year, with Exalted Ruler M. N. Shrago and the other officers of the host lodge conducting the ritual. Highlight of the meeting was an address by Grand Exalted Ruler John E. Fenton at a State banquet which was followed by a dance. Judge Fenton was introduced by Past Grand Exalted Ruler John L. Walker of Roanoke, Va.



YANKTON, South Dakota, Elksdom's annual Father and Son's Banquet attended by 360 was highlighted by an address given by N. Y. Yankees' baseball star, Roger Maris, who received the American League's Most Valuable Player Award for 1960. Maris appears at left, as he obligingly gave autographs to his enthusiastic young fans.



CHAMBERSBURG, Pennsylvania, Lodge welcomes a group of candidates, one of whom is J. Nelson (Nellie) Fox of the Chicago White Sox, second from right, foreground.

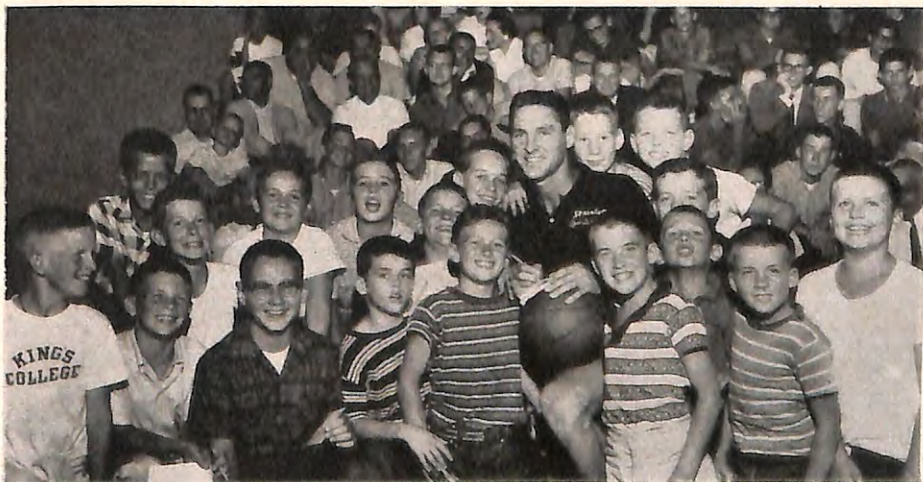

BINGHAMTON, New York, Lodge held a Basketball Clinic not long ago which featured Bill Sharman of the World Championship Boston Celtics of the National Basketball Assn. Bill can be seen surrounded by some of the 400 youngsters and fans who attended the Clinic which consisted of instruction in the fundamentals of basketball and a demonstration of various drills, shots and plays conducted by the Celtics' talented player.



NEW ROCHELLE, New York, Lodge's 7th Annual Civic Achievement Award for 1960 is presented to philanthropist Charles S. Raizen, fourth from left, by Supreme Court Justice George Fanelli, second from left. At left is E.R. Philip Beninato; center, P.D.D. J. Raymond McGovern, and right, Frank Moroze, Master of Ceremonies for the dinner attended by over 300.



WAUKEGAN, Illinois, Lodge honored its Elks National Foundation Chairman Wm. L. Just with a banquet when he was given a check representing 49 new subscriptions to the Foundation. Left to right, seated, are Mr. Just, Toastmaster Harold Tallett and E.R. Stan Zelesnik. Standing are P.D.D. William Carroll, Judge Sidney Block and D.D. Bede Armstrong.



QUINCY, Massachusetts, E.R. E. J. LaCroix, right, presents a \$1,250 check to Msgr. F. P. Schmitt, director of the famed Father Flanagan's Boys Town Choir which made an appearance in Quincy under the Elks' auspices. Others are, left to right, Est. Lead. Knight G. R. Alcott, E.R.'s-aide J. J. Nassano and Mayor A. A. Della Chiesa, a member of the lodge.



HATTIESBURG, Mississippi, E.R. Ray Yorty, left, presents a \$500 check to Pres. Dillard McMullan of the United Givers Fund of Forrest County. Looking on are, left to right, Elk Treas. Robert H. Rollings, Elk Committee Chairman I. H. Buckalter and UGF Exec. Director T. R. Johnson. These Elks have made this \$500 donation to the Fund for five consecutive years.

LODGE NOTES

William S. Gould, Secretary of Scranton, Pa., Lodge since November 8th, 1894, celebrated his 89th birthday on November 21st. An Elk since April, 1893, Mr. Gould had also held the office of State Association Secretary for 41 years, resigning in 1957 because of ill health. A former District Deputy, he has attended 33 Grand Lodge Conventions and held membership on the Grand Lodge Credentials Committee.

Not long ago, Hattiesburg, Miss., Lodge paid tribute to the dean of its Past Exalted Rulers, William A. Thomson, by initiating a class of candidates in his honor. Mr. Thomson delivered the address of welcome to the initiates.

Willard, Ohio, Lodge is mourning the loss of Past Exalted Ruler Carl J. Ehrman who passed away Nov. 23rd at the age of 71. An Elk since 1921, Mr. Ehrman served as lodge Secretary from

1942 to 1948. He is survived by his son, P. F. Ehrman, also a member of Willard Lodge, his brother and four grand-children.

Hard-working Stuart Strong, Past Exalted Ruler of Windsor, Vt., Lodge, sold over 300 books of tickets in the money-raising program benefiting the Vermont Elks' major charity project, "Silver Towers Camp for Retarded Children." The lodge contributed over \$500 to this program in the past year.

Known to his home lodge of Alliance, Ohio, as "Mr. Elk", George H. McConahy succumbed to a heart attack on October 22nd. Dean of Alliance's Past Exalted Rulers, Mr. McConahy had been Secretary of his lodge since 1953. He was 72 years old.

The Tidewater School, a bustling four-teacher unit of the 1930's until it

became an office building and then an employees' recreation center, has recently been purchased by the newly instituted Drumright, Okla., Elks Lodge. Considered one of the most modern structures of its kind, the brick building has been renovated by the Elks for use as their home.

Another branch of the Order to get itself new headquarters recently is Mountain Home, Ark., Lodge whose officers dedicated the building at ceremonies at which Past Grand Exalted Ruler Earl E. James delivered the acceptance speech. State Association Vice-President Dr. Ben N. Saltzman was Master of Ceremonies and the dedicatory address was given by lodge Secretary Robert B. Acheson.

We have mentioned Dr. Fred Conover of Decorah, Ia., Lodge before, principally in our Old Timers in Elkdom



EAST LIVERPOOL, Ohio, Lodge's E.R. John Rippeth, third from left, presents a handsome trophy to Bernie Allen, fourth from left, when 350 turned out for the Elks' homecoming tribute to Purdue University's All-American. Others are teammates Tom Yakubowski, left, and Tom Bloom, right; Allen's backfield coach, Bob DeMosse, second from right, WSTV-TV sports director Red Donley, second from left. Another guest was Tom Jenkins, former Pittsburg star similarly honored in 1957.



BROOKLYN, New York, Lodge captured first place in the Elks National Foundation Drive for the State. Brooklyn Committee Chairman Charles Dardis, left, and P.E.R. Wm. V. Sivillo hold the special award received for this effort.



WOLCOTT, New York, Lodge's Youth Committee under D. A. Douglas sponsored the first annual cross-country run in which more than 30 runners represented 12 schools. Pictured at right is E.R. Richard Camp who presented permanent trophies to the winners in each division, and gold, silver or bronze pins to each starter, depending on their order of finish. Robert Wade won the college title for Alfred Univ.; William Slack of Brighton High won the high school try, with Hannibal High taking the team honors.



WHEELING, West Virginia, Lodge's 50-year Life Member Peter C. Boyd, Sr., adjusts the Elks' pin on the lapel of his son Peter, Jr., selected as spokesman for a class of 26 candidates initiated in honor of D.D. Elwood G. Grisell.

features. We have just learned that Dr. Conover, a retired dentist, celebrated his 101st birthday on November 16th. Retired since 1930, Dr. Conover has little daily activity, spending most of his time in the comfortable chair which was a gift from his Elk friends.

Fifty New York State lodges participated in a two-day ritualistic clinic sponsored by the New York State Elks Association. The first program was held at Ossining Lodge; the second, at Hempstead Lodge. Conducting the clinics were William R. Thorne and Raymond Quesnel of the Grand Lodge Ritualistic Committee and former District Deputy LeRoy Coe.

During the past few years, the Youth Welfare Committee of Terre Haute, Ind., Lodge, headed by J. R. Learned, has been extremely active. The programs sponsored by this Committee

were featured in a handsome window display located about half a block east of the crossroads of the Nation, where U. S. 40 and U. S. 41 intersect, and where traffic on foot and on wheels is very heavy. The display included placards, trophies and so on, all referring to the lodge's scholarship program, the many sports awards it offers, its school patrol sponsorship, the annual patrol picnic and theater parties, and the lodge's fine observances of Elks National Youth Day.

Judge Sherman G. Finesilver of the Denver, Colo., Municipal Court, who is a member of Denver Lodge, is the recipient of the Paul Gray Hoffman Award for distinguished professional services in highway safety. The award was presented at the United Nations offices of the donor, Paul Hoffman, managing director of the United Nations Special Fund.



ST. JOHNSBURY, Vermont, E.R. Wm. B. Roberts presents his lodge's \$200 check to Chamber of Commerce Vice-Pres. R. J. Brisson, starting the \$1,200 drive to purchase flags for community display.



WESTFIELD, Massachusetts



HILLSIDE, New Jersey



WESTBROOK, Connecticut



AMBRIDGE, Pennsylvania



PASSAIC VALLEY, New Jersey

... WESTFIELD, MASS., Elks, court officials and Bar Association members are pictured when a shield, inscribed with the Ten Commandments, was presented by the Elks for display in the Juvenile Court. Left to right are Probation Officer Theodore Couse, Eugene Riley and Secy.-Treas. R. T. Dolan of the Bar Assn., E.R. Simon Wichrowski, Judge A. T. Garvey, Elk Chairman Joseph Ferriter, Bar Assn. Pres. G. F. Buschmann, Youth Chairman Richard Trench, Bar Assn. Member Frank Placzek, Court Officer Gerald O'Connor, Bar Assn. Vice-Pres. A. R. Goldman, Court Clerk R. C. Morrissey and Asst. Court Clerk C. H. Morrissey.

... For the 20th year HILLSIDE, N. J., Lodge played host at a dinner for players, coaches and friends of the Babe Ruth League. Pictured are the Elk-sponsored players who won the championship for the third time. With them are, left to right, background, E.R. J. V. Redling, Co-Coaches Charles Mancuso and Harvey Stone and Youth Chairman George McClatchey. Bob Malkmus, second baseman for the Philadelphia Phillies, was the principal speaker at the dinner attended by over 120 persons. The team and its sponsors received trophies, with special awards going to top pitcher Jerry Avergon and leading batters James Pucci and John Krokosz.

... Youngsters who were guests of WESTBROOK, CONN., Lodge at the party it sponsored for Wanda Lee Hathway and Ronnie Bryant, the wheelchair children pictured at right, were photographed with some of the Elks and their ladies who handled the festivities including Mrs. Robert Stalsburg, House Committeemen Phil Frequeau and Sandy Gosslin, Trustee Morris Austin, Steward Tony Patti, Committee Chairman Carlo Viggiano and State Trustee F. Dibble.

... Pictured when D.D. Harry F. Pepper visited AMBRIDGE, PA., Lodge were, left to right, foreground: Dist. Pres. B. G. Baird, Mr. Pepper, E.R. D. E. Lytle, D.D. Jesse Hutson and Past State Pres. William Hancher; background: Dist. Secy. P. E. Nutter, Dist. Vice-Pres. Edward Brady, State Trustees Chairman Boyd Adams, P.D.D. William Gravelle, Esq. H. K. McNamee, and P.D.D.'s Watkin Wilson, William Brooks, Herbert Ellis, L. F. Laughrey, Clark Buell and R. O. Strickler.

... PASSAIC VALLEY, N. J., Lodge initiated 43 candidates in honor of D.D. Joseph Wallace, pictured sixth from left, foreground, with E.R. A. B. George on his left, surrounded by other officers and the candidates.



LANCASTER, Pennsylvania, Elks who represent 400 years in the Order were among 68 Old Timers entertained by the lodge. They are, left to right, B. F. Barr, 65 years an Elk; J. C. McClain, 60; R. S. Slagen, 55; J. F. Apple and H. C. Kinzer, 52; Edward Siegler, 51; W. C. Dunlap and Herbert Gansman, 50, and oldest active P.E.R.'s H. M. Forrest and L. G. Shenk.



NEWTON, Kansas, veteran Elks who bowled in the 14th annual State Elks Tourney included, left to right, Austin D. Neuhauser, 75 years old; Andrew S. Pearson, 74; J. T. Wray and Wm. S. Lyon, 71, and Chancie Connor, 69. Over \$4,500 was offered in prizes in this match in which 128 teams were entered and four all-time high tournament records were broken.



CAMBRIDGE, Massachusetts, Elks present a 50-star Flag to the Blessed Sacrament Girl Cadets. Left to right are Rev. P. T. Girarden, E.R. F. J. Devaney, Color Guard Captain Mary Ann Harrington, Youth Activities Chairman Bert McCann, Mayor Edward Crane and William Frank.



DOUGLAS, Arizona, Lodge's Boy Scout Troop was host to a Court of Honor when the charter and troop flag for the new Elk group were presented. Left to right are Scoutmaster Henry Beumler, Est. Lect. Knight Joseph Falbo, E.R. Victor Daniel and Elk Vernon Guess, Scout Council Executive.



CRISFIELD, Maryland, E.R. H. T. Phoebus, Jr., right, accepts a State flag for his lodge's new home from Gov. J. M. Tawes.



NORWICH, New York, Lodge's P.E.R. Arthur W. Dietrich, center, is pictured with his four sons, all members of the Order.



TONOPAH, Nevada, Lodge's 14-year Secy. and 41-year member Wm. F. Logan, center, receives an Honorary Life Membership from E.R. John Friel, right, as State Pres. L. W. Lappin looks on.



WELLSBURG, West Virginia, E.R. Fred Martin, left, is pictured with Elks National Foundation scholar Joseph R. Mehall, second from left. Looking on are the young man's parents.

Rod and Gun

(Continued from page 18)

a gun, and a nylon gun should get the same care as any gun; should a person inadvertently stumble (I've fallen down all over North America) and strike the stock or fore end against a hard object, nylon can take the shock better than can wood. It won't chip or split. Likewise, it is impervious to weather. It is unaffected by moisture or temperature; it neither swells nor shrinks. For another thing, nylon is virtually frictionless; that is, in use as a bearing against a movable steel part, it is not only durable but it requires no lubrication. Third, nylon is non-corrosive. Again this doesn't mean that the gun can be abused. The barrel is steel, and a rifle with a pitted bore is about as useless as a broken wheel. This gun requires care, but—since the nylon itself will neither rust nor deteriorate—it requires possibly a little less care than do other rifles. Fourth, the last point as I see it, nylon is light in weight. This 14-shot automatic .22 weighs only four pounds.

Of course, there are other advertised features. One is that the barrel of the rifle is bedded more precisely in nylon than in wood; therefore, that it is more accurate. This may be so. Undoubtedly the designers know what they are talking about. However, I've seen some accurate rifles bedded in wood. Taking the liberty of an assumption, I believe they mean by this that nylon can be turned out of forms with more uniformity than wood can be cut; hence, each barrel, similarly turned out to exacting dimensions, will fit its nylon bedding consistently and precisely. In our machine era, this is important. A large company cannot afford to give each product such personal attention as is necessary to bed the barrel of a fine rifle in wood.

The feature which is truly revolutionary in this .22 is the remarkable use of nylon in the receiver. The parts are virtually indestructible in the normal course of rifle use. They have the necessary tensile strength and—an amazing quality—they never require lubrication. Quite an innovation! As far as a nylon stock and fore-end are concerned, these are merely improvements on an old idea. Some years ago, Stevens brought out a shotgun with an inexpensive plastic stock. But firing it on a cold day would freeze your face, like putting your cheek against a plate of steel.

And perhaps the finest feature of this "Nylon 66" has nothing to do with nylon. It is an automatic rifle; yet at the same time it is the best single-shot .22 available. For single-shot use, it can be loaded rapidly, infallibly and safely, as illustrated. For target shooting, or for use as a boy's gun, this is another step forward.

Everything considered, this autoloading Remington .22 is an advancement in the science of gun making which is as practical as it is spectacular.

We buy and possess guns for two reasons. The first reason is to shoot them. This shooting for some is of interest in the field alone. Others enjoy target shooting as well as actual hunting, and a considerable number of enthusiasts, with either rifle or shotgun, are target shooters only. Some are "plinkers" and they just have a lot of fun, while quite a few are frankly serious. These latter demand the finest in firearms and ammunition, and their satisfaction comes from their ability to score. Many of them engage in competitive shoots, an example being the many trapshooters (about 2,500 in 1960) who compete in the Grand American Handi-

OUR NEED FOR NEGATIVES

Your cooperation in supplying us with negatives of lodge photos will help us maintain a high standard of quality in your Magazine.

While we are receiving this cooperation from the majority of our lodges, and deeply appreciate it, we are publishing this reminder for those who may have overlooked our previous announcements.

cap conducted annually at Vandalia, Ohio. But whether a man fires a few thousand rounds a year, or whether he fires only one shot—at a deer, perhaps—his primary reason for buying a gun, obviously, is to shoot it. This is what a gun is made for.

All except one of the guns which I own (a total, unfortunately, of only five shotguns, two rifles and a couple of pistols) are modern firearms in perfect shooting order. They are all used regularly, simply because I like to shoot, whether it is at a target or at a flying bird. The exception—the non-shooting gun—is a frontier model Colt .45 made one hundred years ago. Although its six-shot cylinder had to be muzzle loaded and fired by means of percussion caps, it was the first successful repeating firearm of any nature. It undoubtedly served time in the Civil War, and who knows what its subsequent history may have been.

It's too loose-jointed for me to fire now even if I were interested in shooting a ball of lead out of a muzzle-loading revolver, which I am not. This pistol serves another purpose. It is here on my desk before me, and I have it

around solely for the pleasure of admiring its long, lean, persuasive lines. As far as I am concerned, it is a thing of beauty.

There are a great many people who own firearms for this reason, and this reason alone. One friend of mine has a Kentucky long rifle mounted on the wall of his den. I have never entered that room without my eyes turning immediately to that gun. It is only a decoration today, to be sure, but the most satisfying decoration a man could wish for. It is slim and graceful, the ultimate in artistry in the history of American gun making.

Other men have extensive collections of such firearms. One I know is interested primarily in Revolutionary War muskets and other early American flintlocks. My dad has a Henry's .44, the breechloading, cartridge carbine which was the first successful repeating rifle and the forerunner of those made by the Winchester Arms Company. Oliver Winchester bought Henry's patent and this was the birth of the famous Winchester lever-action carbine, "the gun that won the West." Even today, almost a century since it was made, this Henry's has a clean, compact, authoritative look.

All the guns mentioned here were milestones in the history of American gun making. Although past their active days, they serve a definite purpose. They are a pleasure just to have around. To possess a gun of beauty, whether it is presently employed for shooting or whether it is solely historical, is a sound reason for having a gun.

Perhaps now, with the Remington nylon .22 and the Winchester glass-barreled shotgun, we are witnessing another milestone. The barrel of Winchester's Model 59 shotgun is made of more than five hundred miles of fiberglass wound about a thin steel core. On top of this, a sleeve of fiberglass is put over the barrel and the whole business fused and finished. The color is the same as the blued barrel of a conventional gun.

And what are its advantages? First, like nylon, the fiberglass is virtually indestructible. It will take a lot of punishment and requires no particular care since it will not corrode. Also, it has enormous tensile strength. It has been proof-tested, taking loads three times heavier than normal without damage. Finally, like nylon, it is light. With this barrel plus aluminum alloys in the receiver, Winchester has taken more than a pound and a half off its standard automatic. This 12-gauge weighs only six and a half pounds, actually less than an earlier 20-gauge automatic. The point of balance is well back in the gun since the recoil mechanism is in the stock and

since the barrel is exceptionally light. This means that it handles fast. The reduced weight can also make quite a difference at the end of a day of toting a gun in the field. But what I like most about it is the way it shoots. It responds fast, feels comfortable and shoots where I'm looking.

As far as beauty is concerned, I have the right to hold my reservations. I'm not impressed by fancy colors in a gun, such as in the nylon .22, and the glass barrel on the shotgun is considerably thicker than steel. It looks like a 10-gauge rather than a 12.

But time will tell. The day of the hand-craftsman is about gone, and our gun makers must produce firearms by machine within the reach of our pocket-books. By comparison, alongside a fine hand-tooled Parker shotgun made thirty years ago, or alongside a highly engraved English shotgun handcrafted even more recently, this modern shotgun looks clumsy and crude to my eyes. But in another thirty years it may have proved to be the inauguration of an entirely new era in gun making.

At the moment (my eyes focus slowly) I see both of these modern guns strictly from the utility point of view. Although possibly not things of beauty, they are the last word in functional firearms: light, sturdy, safe, accurate.

And gun makers must keep on the move. There are many fine shotguns

around the country which necessarily had to be retired. We've all heard that no one should use a shotgun with Damascus barrels, and this is true. There is nothing wrong with Damascus steel, and its intricate pattern added to the appearance of any shotgun. Damascus barrels served well, and would continue to serve well if there hadn't been a marked development in gun powder. Black powder and early smokeless powders went off with an almost instantaneous explosion. Therefore, guns built in that era had very heavy steel around the breech where the explosion took place. This enormous pressure played off rapidly as the shot-charge traveled up the barrel, and the thickness of the Damascus steel barrel was tapered down toward the muzzle accordingly. Then the ammunition people came up with progressive-burning powders. Instead of burning out in one flash, they continue to burn for the entire length of the barrel. Such progressive-burning powders, giving impetus to the shot-charge the entire time it is in the barrel, project the shot faster than did the older powders. However, they also develop pressure toward the muzzle of the gun where the steel in Damascus barrels is thin. Consequently, today's shotgun ammunition is likely to blow a chunk out of the barrel of an old gun anywhere from the fore-end forward.

The Winchester Model 59 is a highly

functional gun made for today's ammunition, today's manufacturing methods, and today's use (or abuse). For ornamental purposes, it shouldn't be kept in the same room with a highly engraved, handcrafted, Damascus barreled shotgun made earlier in this century, but it isn't made as an ornament. It is made for people who like to shoot. I've put a few hundred rounds through mine, and it does its job well. I'll testify to that.

Last summer in Saskatchewan I had the opportunity to talk to a very old Plains Cree Indian. I asked him if the prairie chicken were plentiful in the old days. They were, of course, he told me.

"You ate them when you could, didn't you?" I asked.

"Yes, prairie chicken is very good," he replied.

"How did your people get them when you were a boy?" I went on. "Did you snare them or trap them under nets? I'm curious."

"No," he answered, almost as though I had affronted him. "We shot them."

"With what?"

"With the bow," he replied, then added proudly, "and we did not miss."

So choose your weapon. In the long run it's how you use it that counts. I've never shot prairie chicken with my Model 59, but I know that I would miss some, even with this latest weapon to come off the designer's desk. • •

"EARNED OVER \$2,000.00 IN TEN WEEKS"



INVESTIGATE ACCIDENTS. We train you. Then we assist you to step into an excellent position — or to develop your own lifetime business.

A. J. Allen earned over \$2,000 in ten weeks. Gary Williams doubled his former salary. Jessie Hill says "Had I not learned of Universal Schools' Accident Investigator Course I would still be just another time card puncher; but today I have a wonderful position, and I receive \$3.00 an hour plus an expense allowance."

RIGHT NOW the Accident Investigation and Adjusting Field offers you a tremendous future. Here's why: *This vital business distributes more money than any other service industry.* Last year alone over 200 MILLION ACCIDENTS had to be investigated for Insurance Companies, Airlines, Railroads, Steamship Lines, and Government Offices — and the need for trained men is booming!

You can investigate full time for one company — or earn \$3 to \$10 an hour in *your own business*. No prior experience or higher education needed. And age is no barrier. Here is a field wide open to men 18 to 60.

NOW! FREE Book Gives You All the Facts

Send TODAY for new, illustrated Book mailed FREE. Learn how you can prepare at home in just a few weeks for excellent full time or spare time income. See for yourself how others have doubled and even tripled their earnings. Let us show you how Universal Schools has trained hundreds of men in their own homes spare time — and then helped them add thousands of dollars to their incomes. Absolutely no obligation on your part. No salesman will call. Write at once to me, M. O. Wilson, Universal Schools, 6801 Hillcrest Ave., Dallas 5, Texas.

Mr. M. O. Wilson, Dept. K-2
Universal Schools, 6801 Hillcrest Ave.,
Dallas 5, Texas

Send me free book on Big Money in Accident Investigating & Adjusting Field. No salesman will call.

Name.....Age.....

Address.....

City.....Zone.....State.....

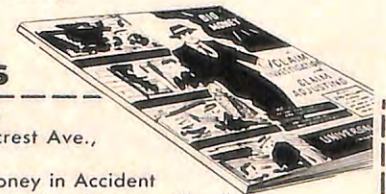

Play Cards with John R. Crawford

You don't have to be an expert to play duplicate bridge



TOMMY WEBER PHOTO

ABOUT 500 different card games are played in this country, but no game has enjoyed such uninterrupted popularity as contract bridge. An estimated 35,000,000 people know enough about the game to play it, and to read and understand the bridge columns that appear in nearly every daily newspaper.

Why has bridge maintained its popularity over so many years? In my opinion it is because bridge, more than any other card game, is a game of skill.

Every bridge player starts out by playing rubber bridge, where the idea is simply to outscore the opponents and the side that holds the best cards usually wins. But right here I would like to expound on one of my favorite subjects.

There is no such thing as an unlucky bridge player. Given a reasonable amount of time, everyone will hold his share of good cards. What he does with them is his business. If he loses, it will be only because he did not play well enough.

Every time people have taken the trouble to tabulate the cards held over a long period, the luck has come out even. In the famous Culbertson-Lenz and Culbertson-Sims matches many years ago, each 150 rubbers in length, there wasn't a difference of more than a trick and a half in the high-card holdings of the opposing sides. When Joe Smith tells me he's an unlucky card holder, he gets very little of my sympathy. I must sadly tell him he just isn't playing well enough.

But how can this be proved? Every winner says he played well and every loser says he was unlucky.

To solve this problem—to eliminate luck as nearly as possible—duplicate bridge was invented.

Very simply, this is a method whereby everyone holds the same hand as everyone else that he compares his result with. If a player does better than other players who held exactly the same cards, it is reasonable to suppose that he played better.

For many years, championships and ranking of bridge players in the United States have been based solely on results in duplicate bridge. But duplicate

bridge is not just for experts. Anyone can play and enjoy duplicate bridge and, also, this is a wonderful way to improve your game.

There are thousands of bridge clubs in the United States. In most large cities a duplicate game is held at some bridge club every night in the week and once or twice a week in smaller communities. There are weekend tournaments, which many of the champion players attend, forty-nine out of fifty-two weeks of the year in various sections of the country, many of them held in Elk lodges.

You won't find duplicate bridge much different from the rubber bridge you already play. When you play a card, you don't toss it into the center of the table; you play it in front of you and then turn it over and leave it there. At the end of the play your hand will go into a special device called a duplicate board, which keeps your hand intact. The duplicate board travels from table to table, so that other players will hold exactly the same cards that you held.

The duplicate board shows clearly who is dealer and which side is vulnerable or not vulnerable.

There is not much difference in the scoring. The biggest difference is that in duplicate you don't play for rubbers.

Each hand is scored separately and is independent of every other hand. You get a bonus when you bid and make a game (300 points if you are not vulnerable, 500 points if you are vulnerable), and you get a bonus of 50 points if you bid and make a part-score. The trick score, sets, slam bonuses, etc., are the same as in rubber bridge.

There are many subtle differences between rubber bridge and duplicate. In duplicate every trick is likely to be important, even an overtrick that might seem unimportant at rubber bridge. Therefore, the play of a hand in duplicate often requires you to take slight chances that you would not take playing rubber bridge.

The hand illustrated below is an excellent example of how you would play a hand in duplicate as compared to rubber bridge.

NOTES ON BIDDING

1 Heart — Sound 18-point opening bid (17 points in high cards + 1 point for distribution).

3 Hearts — One of the most informative bids in bridge. It is forcing to game and shows at least four trumps and 13 to 15 points.

4 Clubs — Slam try (otherwise you would just bid 4♥ or 3NT).



NORTH



SOUTH

Neither side vulnerable. The bidding, with South dealer:

SOUTH	WEST	NORTH	EAST
One Heart	Pass	Three Hearts	Pass
Four Clubs	Pass	Four Diamonds	Pass
Four No Trump	Pass	Five Hearts	Pass
Six Hearts	Pass	Pass	Pass

Opening lead Jack of Clubs.

4 Diamonds — Showing something in diamonds and a willingness to go further (otherwise North would simply sign off by bidding 4 ♥). North goes along with the slam try because he had a strong 15-point double raise.

4 No-trump — The Blackwood artificial bid, asking for the number of aces partner holds. In the bidding of most slams it is wise, whenever possible, to make sure you aren't off two aces.

5 Hearts — Artificial response to Blackwood, signifying two aces.

6 Hearts — On to a slam, gladly. Even if North's response had shown only one ace, South might have gambled on the slam anyway.

THE PLAY

The opening lead of the jack of clubs is of course won by the South hand with the king. The only problem in the play of the hand is to avoid the possible loss of two trump tricks. The small club in South's hand can be discarded on dummy's fourth diamond or can be ruffed in dummy after the trumps are out.

The correct play in duplicate is to play a small heart to the king and (assuming both opponents followed suit) a small heart back to the ace. If the hearts break 2-2 you make seven, and if they break 3-1 you still make six.

The correct play in rubber bridge, however, calls for a safety play. A safety play often gives up a trick that you might not have had to lose, to safeguard against a bad break and guarantee that the contract will be made.

So in rubber bridge South would play the two of hearts from his hand. Supposing that West plays a low heart, this will just be covered by a low heart from dummy. If East can win this trick, it means the suit cannot break any worse than 3-1, and the ace and king will be able to extract remaining trumps.

If your right-hand opponent started with a void in trumps, dummy's card will win the first trick, while if dummy's

(Continued on page 58)

Note To Bridge Players

Copies of the booklet "Team Play and International Match Point Scoring", which Mr. Crawford prepared for Elks Magazine readers, still are available. There is no charge for the booklets, but please enclose a four-cent stamp to cover cost of mailing. Write to The Elks Magazine, 386 Park Avenue South, New York 16, N. Y. Any comments you have about this new feature by the foremost card player in the country will be very much appreciated. For the benefit of members and their families who are reading this feature for the first time, we would like to point out that Mr. Crawford will write not only about bridge, but also other card games of interest to the family.

Featuring "Vacationland Banking," The Rangeley Trust Company provides financing for many commercial resort areas, private homes and cottages in Maine's lovely Rangeley Lakes region. The bank provides insurance coverage for its employees and their families through a New York Life Employee Protection Plan.

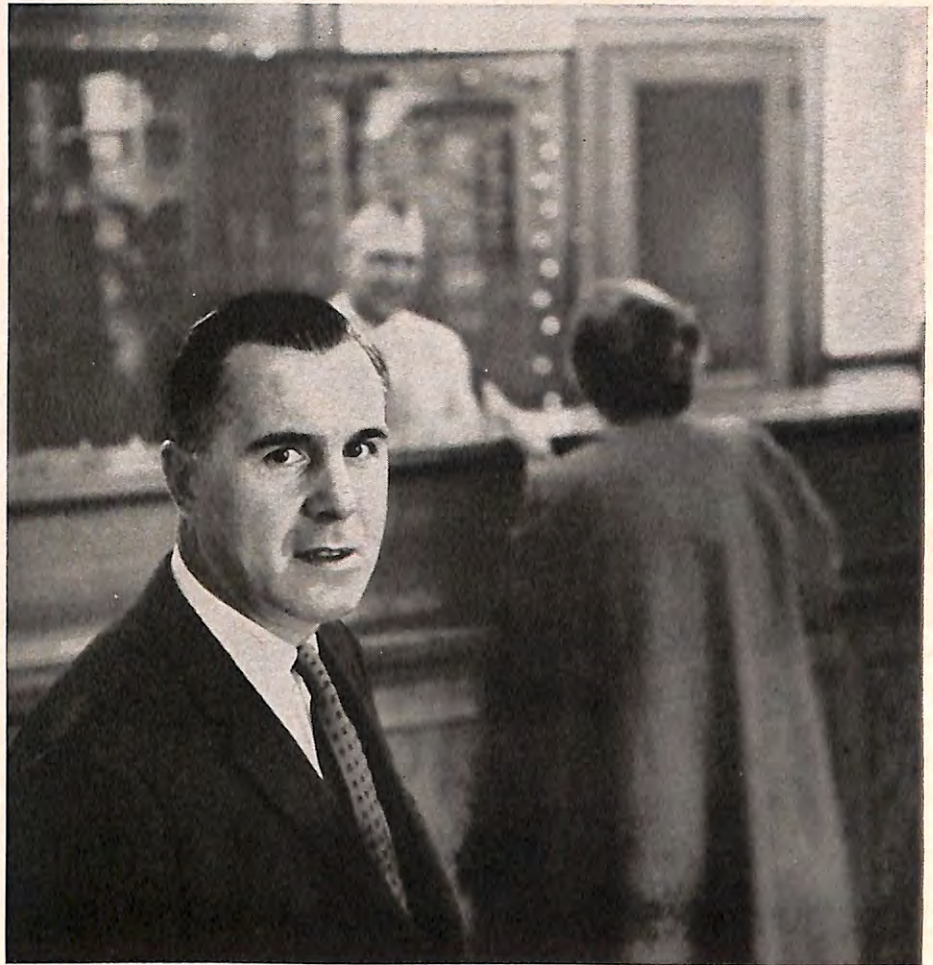

"This insurance has helped
cut our
employee turnover in half..."

SAYS SHELTON C. NOYES, President, Rangeley Trust Co., Rangeley, Maine, about his bank's New York Life Employee Protection Plan. "It gives our employees one of the benefits that larger businesses can offer . . . placing our small business in a competitive position for valued employees."

More and more companies with four or more employees are finding New York Life's Employee Protection Plans an excellent way to help build morale, attract and keep high-grade people. These Plans offer a wide choice of coverages including: life insurance, weekly indemnity*, medical care benefits, and in most states major medical coverage.

IMPORTANT EXTRA! Additional personal or business insurance may be purchased through New York Life's

Nyl-A-Plan at rates lower than the regular monthly rates. This service, which may be installed with most employee benefit plans, or separately, helps you and your employees develop sound insurance programs by coordinating your company benefits, including Social Security, with personal insurance. Nyl-A-Plan helps to protect your investment in your entire employee benefit program.

Talk to your New York Life Agent now. Or write: New York Life Insurance Company, New York 10, N. Y.

NEW YORK LIFE
LEADER IN BUSINESS INSURANCE



Individual policies or group contract issued, depending upon number of employees and applicable state law.
*Weekly indemnity not available in states with compulsory disability or cash sickness laws.

IN THE DOG HOUSE

Three Norwegian Elkhounds, each with the chain leash and choke collar described below.

Supplies for the Dog—and Owner

By ED FAUST

RECENTLY, one of these essays reported a consensus among the Solons of dogdom that no less than twenty-six million dogs are in the United States. As you may recall, your man Faust questioned the accuracy of this opinion, as no official canine nose-count had been made. But there is no doubt that Fido has millions of relatives decorating the American landscape, so many that three hundred and fifty million dollars (a verifiable figure) was spent for dog food in this country during 1959. And that's a lot of money for a lot of food for a lot of dogs.

This isn't the only industry that keeps the groceries on the table because of our four-legged friend. There are many more, involving thousands of people. Suppose we give a look-see at things many dog owners are buying to enhance the happiness and welfare of their pets.

You may find a helpful suggestion or two.

First, there's the assortment of foods, a subject which in itself warrants a full-length article explaining what, how and when to feed. For the present, let's see what kinds of food you'll find in your local market. It's a toss-up between canned and dry foods. Both of these commercial foods are excellent. The canned varieties are a trifle more convenient to feed for the very busy owner than some of the dry foods, which may need the addition of water, broth or other moisture, although this is not true for all dry foods. All of the advertised, better known dog foods are good. It's mostly a matter of mixtures and vitamin content, and it's a wise dog owner who takes the trouble to examine the label whereon are listed the ingredients and their vitamin content. Aside from being inexpensive, all of the commercial foods offer the quickest and most convenient way to fill Fido's din-

ner pail. And many containers even tell how much and how often to feed a dog of a given age or weight. Such foods are a big improvement over the table-scrap method that made the meals for many dogs before commercial foods became popular.

While dog candies aren't foods sufficient in themselves, they do contain necessary vitamins and get a vigorous tail-wagging welcome from practically all dogs.

Not many owners neglect to buy a collar or harness for their dogs. I'd say the former is a necessity. The harness is an indulgence for the dog that hasn't been trained to walk without excessive pulling on its leash. It's rarely if ever employed on a show dog, as it has a tendency to alter gait and the conformation of forelegs. For the stubborn fellow that persistently chokes as he tries to forge ahead of his master, a choke collar is an effective cure. This is a running noose job, either a short

chain or leather. It's also often used on large or extra-powerful pups. The collar provides a means of fastening an identifying license tag and is the most convenient "handle" to grasp to control the dog. The flat type of collar is for the short-haired dog, the rounded kind is best for the rough or long-coated animal.

The highly ornamented, stone-studded collar is all right for the toy tykes, but to this writer's way of thinking it makes a dude out of the average-size dog. Time was when the wide, brass-spiked collar was the style for the bulldog and others of similar kind. Maybe this was used with the idea that it made the dog appear a tough citizen, as if anything could make loveable old sourpuss more forbidding.

As for a leash, you can use anything from a piece of rope to a sturdy flat leather variety or even a chain, the weight depending upon the size of the dog and its strength. There's a type that combines leash with choke collar in one piece.

Another accessory more needed for small dogs than the larger ones is a bed. Most stores selling dog supplies offer them or can get one suited to the size of the dog, and here the owner should allow for plenty of room. By the way, once the dog's sleeping place is decided it should not be changed. Bedding can be a cushion, an old blanket or, for summer, a few sheets of newspaper. Both beds and bedding should be aired regularly and washed, if possible with a mixture of water and a mild antiseptic, every few months and dried outdoors in the sunlight.

If Mr. Dog has too many unwanted boarders, a light sprinkling of flea powder should be given the floor of the bed after it is washed. What Fido did other than scratch before those powders were marketed I don't know, but life must have been tough for him. Today such powders can be bought in almost any drug store. The better known varieties are all effective, provided they are used exactly as directed by their manufacturers.

Medicines for internal parasites can also be had from the druggist, and these too should be used exactly as the manufacturer directs. It should be noted that those sold for grown dogs should *never* be given to puppies. The label on the container may warn about this.

This brings us to the dog's medicine chest. This should hold only the most simple supplies, usually for injuries and not for home doctoring where there's a suspicion of illness. In it there should be a supply of mineral oil as a laxative for Fido, and if the dog is very young a stock of cod liver oil will be part of the medical equipment (although strictly speaking this is for use as a food supplement, not a medicine). You can add petroleum jelly to the list for minor skin irritations and over-dry nasal



The best-selling builders buy Brand Name materials

Why do you buy Brand Names? Because you trust them. You know that they are consistently good, that they always meet the high standards of quality you've set for yourself and your family. You'll find Brand Name products wherever you go. No guesswork shopping. Like good friends, they're always there.

The Brand Name manufacturer has built a reputation. He must maintain it, so he keeps his standards high, and strives constantly to make his product better. He's always first with new products and ideas. He employs lots of people. He helps balance the economy. You depend on him. He depends on you. *Know* your brands, and buy the brands you *know*. You'll find some of them on the pages of this magazine.

LOOK FOR

A Brand Name is a Maker's Reputation



Brand Names Foundation, Inc., 437 Fifth Avenue, New York 16, N.Y.

How to Know and Care for

Your DOG

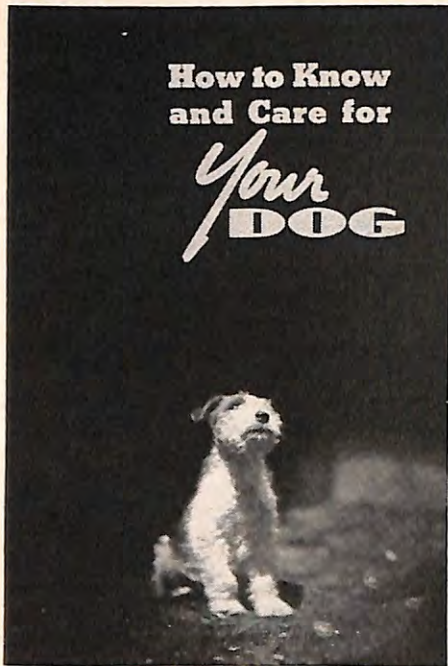

This is the title of the dog book by Ed Faust, author of "In the Dog House" which appears regularly in The Elks Magazine. The 48 pages of this book are packed with information that will help you care for your dog. Here you'll find answers to the problems of feeding, training, common sickness—told concisely and in an easy-to-read manner. Many illustrations and descriptions of popular breeds. Thousands of copies have been sold to pleased readers. Endorsed by leading dog authorities.

PRICE ONLY 35c POSTPAID

Please do not send stamps

IT'S THE ANSWER

to your dog problems—so

SEND FOR IT TODAY

Please print name and address

THE ELKS MAGAZINE
386 FOURTH AVENUE
NEW YORK 16, N.Y.

passages. Borax crystals plus tincture of iodine should be on hand for antiseptics in case of cuts or wounds. Sulphur ointment or water of lead (see your druggist) will frequently check a skin rash in its early stages. Add an ounce of aromatic spirits of ammonia to stimulate the dog's breathing when necessary. Also in the chest should be an ounce of tannic acid powder for burns that are not too severe. For abrasions or inflamed eyelids, 1 per cent yellow oxide of mercury should be available. And a few aspirin tablets will help quiet a highly excited dog or ease pain a bit. Add to the list a roll of adhesive tape, two rolls of bandage, one about an inch wide, the other at least two inches, and a pair of small scissors.

The careful owner will only use the medicine chest for simple emergencies and when in doubt, or in case of a bad cut, wound or burn he'll waste no time nor risk his dog's life by trying to play veterinarian. Nor will he hesitate to take the dog to its doctor if it shows signs of being unwell. Fees asked by veterinarians are rarely if ever excessive, and a prompt trip to the vet may forestall what through neglect or mistaken economy may become a serious illness or result in the death of the dog.

Incidentally (and where these pests flourish it's not an incidental matter), a reputable veterinarian recommends the following as a knockout for ticks: any sort of good insecticide added to one pint of alcohol. After applying this, wait one half to one hour and then give the pup a bath. A good soap made for dogs should be used. Here again, the drug store has such soaps. Only soaps made for dogs should be used and never the kind intended for human use, as many of the latter contain caus-

tics and other ingredients harmful to a dog's coat.

Other important things the well-equipped dog should have are a comb and brush. These need not be expensive. If there are any real five-and-dime stores still doing business, you can get the comb in one, if you can still buy a comb for a dime. For the brush you'll have to go higher but it need not be one as good as your own. Bristles should be a bit longer for the dog with a long coat than for his short-coated cousin. A brush with wire bristles should never be used. Nor should the fine-toothed half of the comb be employed on the fellow with a rough or long coat, as it will pull out too much live hair.

Those who take their dogs seriously, professionals or amateurs, are usually opposed to blankets for dogs other than the tiny tykes in the toy division, and then not for the long coated kinds, pomeranians, toy poodles etc. To the writer a husky, medium or large dog wearing a coat or blanket looks like a sissy. I know, racing greyhounds are blanketed, but the covering is a wisp of a thing and serves to carry the dog's track number. A raincoat, however, comes under the heading of utility. There are times when it may be necessary to take a dog out in the rain or where there's much snow, and a wet dog around the house doesn't improve the atmosphere, the rugs, the furniture or one's clothing. Raincoats can be bought where dog supplies are sold, or can be ordered from one of the larger mail-order houses. Blankets for the small, short-coated dogs can also be obtained from the same sources. The average pet-shop owner very likely won't sell you dog clippers or stripping combs; many of them are in the busi-



"Well, I kept my New Year resolution. I'm reading a book."

THE ELKS MAGAZINE

ness of clipping or stripping dogs themselves. If you feel capable of tidying your dog's coat, then the instruments can be had in most places selling a full line of dog supplies or, again, from mail-order houses.

If you'll drop me a line, I'll tell you where clippers or stripping combs can be bought. There are do-it-yourself charts for a variety of different breeds that show in detail how such grooming can be done at home. However, if the dog is a mixed breed, there's no chart for him.

A dog doesn't much care what kind of dish contains his food, but some owners are concerned and these can, of course, find a variety of dog dishes in almost any store selling housewares. For the dog with long ears a deep dish with a fairly narrow opening helps keep the ears out of the food. For the short-eared dog, almost any kind of dish will do, provided it has a high enough rim.

As all dog owners know, dogs like toys—things that they feel belong to them. An interesting toy does much to keep the chewer from working on rugs, furniture, shoes and other chewables. A pretty good assortment of doggy playthings can be found in most variety stores, but if you value your sanity don't get one of those squeaking rubber mice or rats. If you do, you may wish Fido was back in his kennel. There are plenty of other noiseless gadgets for his play. If you have the room and want to keep the dog outdoors, you can easily build a house for him; if you haven't the time or are not tool-wise, there are several woodworking firms that sell excellent knock-down dog houses which only call for a screw driver to put together.

I'll be glad to tell you where they can be bought by mail. One of the most often-asked questions in my reader mail is what to do to keep a dog restricted to its home grounds without chaining it to a small area. This is a problem to the owner who doesn't want to make a prisoner of the dog (this sometimes results in souring the dog's outlook on life and perhaps making it a bad tempered animal). But it's a problem easily solved by the erection of a dog trolley. This the owner can do himself, or, better still, buy the trolley ready-made. By the time the do-it-yourself owner shops around for the materials he will very likely spend more than the cost of the complete equipment, sold ready to erect by mail-order advertisers. In either case, all the boss of the pooch need supply are two posts or trees as terminals for the trolley wire. If you want to do the job yourself, or want to know where to buy the more convenient ready-to-install gear, I'll tell you about both. If you have any questions about dogs other than medical, drop me a line. I'll try to solve your problem.

DISCOUNTS TO CHURCHES ETC. UP TO 40%



NO. K-3 TABLE
Tempered Masonite
Plasticized Top

Again Offering
ALL NEW
Monroe
FOLD-KING
FOLDING TABLE LINE

STEEL FOLDING CHAIRS

TRUCKS FOR TABLES, CHAIRS

MOVABLE PARTITIONS

FOLDING RISERS

Monroe
CATALOG in COLORS

Kitchen committees, social groups, attention! Direct - from - factory prices—discounts to 40%—terms. Churches, Schools, Clubs, Lodges and all organizations. Our new **MONROE 1961 FOLD-KING FOLDING BANQUET TABLES** are unmatched for quality, durability, convenience and handsome appearance. New completely automatic lock on pedestals and legs.

FREE BIG 1961 CATALOG LOW DIRECT PRICES
Shows the full line of Monroe Fold-King folding tables, folding chairs, table and chair trucks, platform-risers, portable room partitions, bulletin boards. Also lists prices, discounts, terms. Our 53rd year.

THE MONROE COMPANY
90 Church St. • Colfax, Iowa

YOU SHOULD SEE THIS BOOK

before ordering
BRONZE PLAQUES

- MEMORIALS • HONOR ROLLS
- TABLETS • TESTIMONIALS

Write for Free Catalog A-74 For Medals and Trophies ask for Catalog B-74



INTERNATIONAL BRONZE Tablet Co., Inc.
150 W. 22nd St., New York 11, N. Y. WA 4-2323

ACCOUNTANT

BECOME AN EXPERT

..AUDITOR..CPA

The demand for skilled accountants—men and women who really know their business—is increasing. Those who prove their qualifications in this important field are promoted to responsible executive positions. No previous experience necessary. We train you from ground up, or according to your individual needs. Low cost; easy terms. Send today for sample lesson and Free illustrated book describing the LaSalle Accounting training and the opportunities in this highly profitable field. Accredited Member, National Home Study Council.

LASALLE EXTENSION UNIVERSITY
A Correspondence Institution
417 S. Dearborn St., Dept. 2328HR, Chicago 5, Ill.

Please send Free Book and full information about the training program checked.

- | | |
|---|--|
| <input type="checkbox"/> Accounting | <input type="checkbox"/> High School |
| <input type="checkbox"/> Bookkeeping | <input type="checkbox"/> Secretarial |
| <input type="checkbox"/> Law: LL.B. Degree | <input type="checkbox"/> Dental Assistant |
| <input type="checkbox"/> Business Management | <input type="checkbox"/> Auto Body Fender |
| <input type="checkbox"/> Sales Training | <input type="checkbox"/> Drafting |
| <input type="checkbox"/> CPA Training | <input type="checkbox"/> Welding |
| <input type="checkbox"/> Foremanship | <input type="checkbox"/> Diesel |
| <input type="checkbox"/> Stenotype
(Machine Shorthand) | <input type="checkbox"/> Motor Tuneup |
| <input type="checkbox"/> Traffic & Transportation | <input type="checkbox"/> Refrigeration-Air
Conditioning |

Name.....Age.....

Address.....

City, Zone, State.....

BOOK OF MEMORY
in everlasting bronze

For listing 100 to 3000 names economically. Write for free catalog showing photos of hand-chased cast bronze plaques. 2 SIZES—4 DESIGNS

NEWMAN BROTHERS, Inc.
Dept. 722, Cincinnati 3, Ohio



...when you need PRINTING and your budget allows only MIMEO... Gestetner



GIVES YOU PRINTING QUALITY AT MIMEO COST

Stationery Literature Forms Bulletins Pictures The amazing print-like quality of this new mimeo process is made possible by Gestetner's press-like design. It uses printer's style paste ink, dual cylinders, and automatic controls for inking, feeding, counting and even jogging. It will reproduce anything, from a halftone to a typed letters. Gestetner costs no more than the old fashioned mimeo.

Gestefax makes your stencils automatically by electronics.



Simply turn the switch. In a few minutes you will have a finished ready-to-run stencil in perfect detail.

.....

GESTETNER CORPORATION
216 Lake Avenue, Dept. 21, Yonkers, N. Y.

Send descriptive literature and specimens.

NAME _____

COMPANY _____

ADDRESS _____

CITY _____ STATE _____

Elks National Service Commission

Remembering Pearl Harbor was given deeper meaning by the Elks of Springfield, Ill., when E.R. Paul Kunzweiler, left, received the first plaque ever subscribed for the *USS Arizona* Memorial Shrine at Pearl Harbor by any organization in the United States. Presenting the plaque in behalf of the Navy Club of the U.S.A., mainland representative of the Pacific War Memorial Commission, is C. R. Topp, right, past national commander of the water-borne veterans organization and a member of Springfield Lodge. Looking on is Est. Lead. Knight C. H. Winn, also a Navy Club member.

After 20 years, the *Arizona* is being established as a national cemetery commemorating the 1,102 men whose bodies are entombed there. A total of \$200,000 is still needed to complete the shrine, scheduled for dedication May 30th, 1961.

These plaques are available only from the Navy Club, 1405 East Ash Street, Springfield, Ill., and all subscriptions are turned over to the *Arizona* Shrine Fund, with the exception of the actual cost of the plaque which is less than a dollar.



Remembering those away from home, particularly at Christmas-time, Lynbrook, N. Y., Lodge sent large gift packages to all servicemen and women from that community who were overseas for the Holidays. The names were obtained from their families and friends who responded to a series of ads, placed in local newspapers by the Elks, requesting this information. At left is E.R. Arthur Bangs; at right is Service Committee Chairman Edward Wachter.



Remembering our heroes on Veterans Day, Chambersburg, Pa., Lodge was represented with a float in the community's parade commemorating November 11th, 1960. The float carried a representation of the Elks' altar, complete with emblem and flags as a reminder of this patriotic Order in the development of the United States as a nation.

Battle Report

(Continued from page 15)

before the bench, wearing his "lucky" chocolate-brown suit, a blue baseball cap and rubber-ribbed cleatless football shoes for fast moving about. Quickly, he did a number of things—beginning by checking the Ram line-up now on the field. He found no surprise faces there. But a couple of shockers were coming up. Next, Ewbank checked his bench. He places his offensive platoon on one side of the midfield table holding the telephone equipment, which links him with his "eye-in-the-sky" spotters in the press box, with the defensive platoon sitting on the other. He studied Unitas, warming up, carefully.

The golden arm of Johnny U. scored a NFL record of 32 touchdowns in 1959 and currently was working on a streak in which he'd delivered at least one touchdown in 47 consecutive games—downright stupendous, considering that Cecil Isbell's 23 straight touchdown games for Green Bay in the 1940's is the next-best showing. In the past two weeks, however, injuries to Colt running backs and receivers had hampered Unitas and brought back-to-back defeats by San Francisco, 30-22, and Detroit, 20-15. Ewbank's problem was thorny. Should he ease up on the aerial game and run hard against the Rams? Baltimore has gained success as a passing outfit, accumulating around 2,500 yards per season overhead as against an average 1,800 running. But what about Unitas's lack of targets—the injury of Berry's, the fact that Ewbank's other star end Jim Mutscheller, was slowed by an injury? What of the report that the Rams recently had shored-up their notably weak pass defense? What of the fact that Weeb's No. 1 full-back, Alan (The Horse) Ameche, was in a Baltimore hospital for repairs, lost to the Colts for the season?

All these considerations almost visibly churned through his head as Ewbank barked, "All right, everybody!" The Colts grouped around him on the sideline.

From my seat, I could gain no notion of what he said, but later I learned that it amounted to: "Don't throw for a while—run at them and see what happens." In the main, Ewbank allows Unitas to call Colt signals. However, he likes to give his quarterback a few game-opening plays to set the initial strategy.

At the kick-off, Ewbank didn't go near the bench. His command post is up front, 15 yards to either side of the 50-yard mark, which area is NFL limit on a coach's movements. Some coaches flaunt the rule. Weeb stays within bounds, lets his overhead scouts brief him by phone on action near the goal line.

The Rams kicked off and the Colts struck back with five straight running

DO YOU OWN OR MANAGE A STORE?

Often, prospective advertisers for THE ELKS MAGAZINE request information concerning the number of Elks who are owners or managers of retail stores. Of course, the larger the number we can quote, the stronger is our portrayal of THE ELKS MAGAZINE as a forceful advertising medium.

If you have not returned the coupon below, will you please do so today. The return of the coupon will be of material assistance to your MAGAZINE.

●
THANK YOU—In response to a facsimile of the dealer coupon displayed here, Brother John J. Cummings, PER of Ridgewood, N. J., Lodge No. 1455, now residing in Toms River, N. J., and Brother Walter F. Kelly, Sr., Secretary of Toms River Lodge, jointly sent THE ELKS MAGAZINE a list of all Toms River members engaged in retail business.

THE ELKS MAGAZINE takes this opportunity to thank Brothers Cummings and Kelly and the hundreds of members who have returned the dealer coupons.

THE ELKS MAGAZINE

386 4th Avenue, New York 16, N. Y.

MY NAME IS _____

ADDRESS _____

CITY _____ STATE _____

TYPE OF BUSINESS _____

(PLEASE CHECK BELOW)

I OWN THIS STORE

I AM PART OWNER OF THIS STORE

I DO NOT OWN BUT MANAGE THE STORE

261

Bass Fisherman will Say I'm Crazy . . .

until they try my method

But after a fair trial, if you're at all like the few other men who know, you'll guard it with your last breath

I have no fishing tackle to sell. I make a good living out of my regular profession. But fishing is my hobby. And because of this hobby, I discovered a way to get those giant bass—everytime I go after them—even in waters most fishermen say are "fished out."



I don't spin, troll, cast or use any other method you ever heard of. Yet, without live or prepared bait, I can come home with a string of 5 and 6 pound beauties while a man twenty feet away won't even get a strike. You can learn my method in a few minutes. It is legal in every state. All the equipment you need costs less than a dollar and you can get it in any local store.

No man who fishes your waters has ever used my method—or even heard of it. When you have tried it—just once—you'll realize what terrific bass fishing you've been missing.

Let me tell you about this method—and explain why I'm willing to let you try it for the entire fishing season without risking a single penny of your money. There is no charge for this information. But I guarantee that the facts I send you can get you started toward the greatest bass fishing you have ever known. Send me your name today—on the handy coupon. You've got a real fishing thrill ahead of you.

ERIC T. FARE, Highland Park 37, III.

**Eric T. Fare,
HIGHLAND PARK 37, ILLINOIS**

Dear Mr. Fare: Please send me complete information without any charge and without the slightest obligation. Tell me how I can learn the method of catching big bass even when old-timers are reporting "no luck".

Name.....

Address.....

City.....Zone.....State.....

FOR MEMBERS ONLY

Nothing except a paid-up member's Card Key will unlock this door. More than 1/3 of ELKS lodges are now using Card Keys.

Be sure your lodge gets the benefit of Card Key System. Write for free descriptive brochure.

CARD KEY SYSTEM, INC.
P.O. BOX 589, BURBANK, CALIF.



FOR MEMORABLE OCCASIONS PLAQUES IN BRONZE OR ALUMINUM

A few dollars buys a lifetime of appreciation with United States Bronze plaques, honor rolls, testimonials, memorials, and awards.

UNITED STATES BRONZE Sign Co. Inc.
Dept. E, 101 W. 31st Street, N. Y. 1, N. Y.

plays, then were forced to kick from their 25-yard line. Even before then, the phone manned by line coach Herman Ball—perched upstairs—was ringing. The effect on Ewbank wasn't startling. But you could see he was unhappy.

Standing next to him with earphones clamped to his head was another assistant coach and Ewbank's field-phone man, John Sandusky. Ball's call only confirmed what both of them already had discovered.

Coach Bob Waterfield of the Rams had pulled one of the season's surprise tactical moves out of his sleeve. He had shifted two of his fleetest offensive stars, Olympic sprinter Ollie Matson and end Del Shofner, to the defense. Now the speed of Colt receivers was matched, if not overmatched. For only Lenny Moore, among the Colts' three main targets for Unitas, was in shape to run with the usual elusiveness.

"Damn it," growled a Colt, sitting next to me. "They must have noticed that Berry and Mutscheller didn't warm up well."

Some hours later, Waterfield confirmed this. "Maybe a little bird chirped to me," he said, mysteriously. "Those Colt ends sure didn't look right in the warm up at any rate. Of course, it could have been a trick by Ewbank to throw us off. But, like I say, maybe we knew something in advance."

Espionage—a pro team can live or die by it.

Ewbank's dilemma became clear from my vantage point of the bench. Now he began to shrug his shoulders and hitch up his coat, a nervous habit which means bad trouble afoot. Unitas launched a first-period drive. In 17 plays, he moved the Colts 64 yards to the Los Angeles 17-yard line. And there the secret weapon of the Rams—big Ollie Matson—hit the Colts a stunning blow. Unitas hook-passed to Ray Berry. Berry had the ball on the five-yard line but Matson slammed into the

injured end, hip and thigh, jarring the ball from his hands. The league's best receiver limped out, not again to be of help to Baltimore.

Unitas overthrew Lenny Moore, who was loose in the Ram end zone. The Colts, on fourth down, had to settle for a field goal by Steve Myhra and a 3-0 lead. The loss of a sure touchdown here—when Berry was knocked loose from the aforementioned pass—was to prove deadlier than it now seemed.

Yet, on the bench, it was easy to see why the Colts remain the pro game's most dangerous combination. No small thing is overlooked, even with the distraction of bad breaks. Ewbank rushed in Steve Plunkett at tackle. Plunkett was keyed up, and from all along the bench came remindful Colt voices yelling, "Report! Report!" Plunkett wheeled and reported to the referee, saving a five-yard penalty.

But nothing else went right. Unitas again overthrew Lenny Moore, who was open. Ram linebacker, Les Richter, and corner man Ed (Killer) Meador cut the legs from under Colt runners. A Baltimore receiver dived for a sideline pass—straight where Weeb Ewbank stood—missing by inches, and almost knocked Ewbank kicking. Moments later, Ewbank coolly beckoned Unitas to the sideline. It was fourth down on the Colt 45-yard line, with what looked like about a foot or more to go to gain a first down.

"How about it," called Unitas, approaching.

Ewbank squinted along the line of the ball and chain marker on the field's far side. "It's less than a foot—just inches. Go for a first down," he ordered.

On the quarterback sneak that followed, Unitas gained only inches—and it was enough. Ewbank's eye had been accurate. Unitas said later he had intended to kick.

Two plays later, Marchetti, although badly shaken up on a previous play,

R. Chess McGhee

R. Chess McGhee, a member of Lynchburg, Va., Lodge, No. 321, for over 55 years and an Honorary Life Member since 1928, passed away November 15th at the age of 76. His wife, daughter and son survive him.

Mr. McGhee's loyalty and devotion to Elkdom were widely known. He had been Exalted Ruler of his lodge in 1910, and had represented it at more than 25 Grand Lodge Conventions. In addition, he had served as District Deputy in 1927, as President of the Virginia State Elks Assn. in 1938 and as the Order's Grand Tiler in 1942.

Mr. McGhee was the oldest employee of the Lynchburg Newspapers in length of service, having been hired in 1896, and had been the recipient of various honors in this field. At the time of his death he was advertising director of *The News* and *The Daily Advance*. In relating some of his Elk activities, a 1949 clipping of *The News* read: "During his 22 years as Esquire of his lodge, he has missed only three meetings, each time because he was at a meeting of an out-of-town lodge." Mr. McGhee was still serving as Esquire at the time of his death.



landed on Frank Ryan, the Ram's No. 1 quarterback, like a runaway truck. Two things happened. Marchetti deflected Ryan's pass, which Milt Davis of the Colts intercepted on Baltimore's 19-yard line. And Ryan's shoulder was separated by the impact. He left the field—out of the game, out for the season. Up close, pro football reveals itself as far more violent than even veteran fans suspect. Dust boils, men cry out in hurt, faces contort savagely, the thudding sound of bodies colliding head-on comes to your ears.

Now the Rams turned their 80,000 crowd into a roaring mob.

Billy Wade, replacing the injured Ryan, threw one of the most tremendous passes in pro history from his eight-yard line. It came down on the Baltimore 29, where rookie end Carroll Dale snared the 63-yarder with a fantastic dive. Sound waves beat on the Colt bench, hurting the ears.

None of the Colt organization panicked. Team doctor McDonnell was busy fitting Lenny Moore with rubber-padded dark glasses—the sun was in his eyes. A plate on lineback Dick Szymanski's face guard was torn loose. Prop man Schubach grabbed pliers and screwdriver, fixed it in 60 seconds, and Szymanski missed only two plays.

And on the field, the Rams, after that phenomenal pass, were stopped. Johnny Sample intercepted a Wade pass, as the half ended with Baltimore clinging to a 3-0 lead.

During the intermission, three guards stood at the Colts' door. No one goes in once that door is shut. Later, Ewbank said he hadn't made any speeches. "We gave 'em first aid, discussed ways and means to get tougher and decided to concentrate on rushing Wade the second half."

Line coach Sandusky confirmed that Ewbank isn't the emotional type when the Colts are lagging. "Once, when we trailed San Francisco, 27-7 at the half time, the boys thought he'd give them hell," Sandusky said. "He came in cool and calm and just wrote on the blackboard—'We Need Four TDs!' That's all. He was so sure we'd get those points that he inspired them to do it. We won the game, 35-27."

On this day, Ewbank needed all his control. No sooner had the second half opened than Billy Wade pulled the fluke maneuver of the season. The toed-in, heavy-legged Ram quarterback never before had run more than 24 yards from scrimmage. Rarely had he been trusted with running. Now, though, he rolled to his right on an option play—watching linebacker Bill Pellington of the Colts. If Pellington moved up, Wade would pass.

Pellington moved back, sensing a pass, and Wade began a tentative run. Caught by surprise, the Colts were mowed down by blocks from Red Phillips, Joe Marconi and others. The as-

ANOTHER of Vitamin-Quota's Matchless Money-Saving Offers!

2-For-1 Sale

Over 100,000,000 capsules already used

of VIM-O-CAPS
AMERICA'S FAVORITE
FOOD SUPPLEMENT



11 VITAMINS 9 MINERALS

in a
single
capsule

Including the important "Red" Vitamin B₁₂
Along with Other Stimulants for the Growth of
RED BLOOD Cells

It matters not where you have purchased vitamins heretofore—Drug, Department, Health Food, Variety Store, Mail Order or Supermarket—the low cost of this amazing formula, on a startling 2-FOR-1 SALE, cannot be equaled anywhere. You get 200 capsules—a full 6 months' supply—for only \$2.25. One a day is an adequate dose.

Each Freshly-Packed, Guaranteed-Potency Vim-O-Caps Capsule Contains:

11 VITAMINS	Vit. B-6	0.75 Mg.	Folic Acid	0.34 Mg.	Iron	13.4 Mg.
Vit. A 6,000 USP units	Vit. B-12	5 Mca.	Calcium	20 Mg.	Magnesium	7.5 Mg.
Vit. D 1,000 USP units	Vit. C	60 Mg.	Phosphorus	15 Mg.	Iodine	0.1 Mg.
Vit. B-1	Niacinamide	20 Mg.	Copper	1 Mg.	Manganese	1.5 Mg.
Vit. B-2	Cal. Panto	5 Mg.			Potassium	5 Mg.
	Vit. E	1 Int'l U.			Zinc	1.4 Mg.

2 BOTTLES of 100 \$ 2.25
2 BOTTLES of 250 \$ 4.85
2 BOTTLES of 500 \$ 9.00
2 BOTTLES of 1,000 \$17.50

Buy the larger sizes for greater savings.

YOUR PURCHASE IS FREE IF THESE SENSATIONAL VALUES CAN BE DUPLICATED ANYWHERE

For over 38 years Vitamin-Quota has saved money for doctors, hospitals and over 2,500,000 families coast-to-coast. BUY IN CONFIDENCE! All orders supervised by Qualified Pharmacists.



VIMOCAPS are sold only at the Addresses Below. Order C.O.D. or save all charges by sending check or money order. We pay all postage. MONEY BACK IF NOT SATISFIED.

38th Year **VITAMIN-QUOTA** 1923-1961

Dept. A-225, 880 Broadway, New York 3, N. Y. or
Dept. A-225, 1125 S. Crenshaw Blvd., Los Angeles 19, Calif.

Sales in Calif., add 5% to total of order.

Prescription Specialists and one of the world's Largest Distributors of Vitamins. Est. 1923.

MEN AND WOMEN WANTED—SPARE TIME
IT AIN'T SELLIN'—just servicing. Take over YOUR AREA as our Service Distributor, keeping retail stores supplied. Nationally advertised 30-year-old line pays you up to \$20 an hour. For samples, highly successful plan—FREE—write NOVO, 3855 Lincoln Ave. Dept. B-10, Chicago 13

Nose Hair Scissors



ONLY \$1.25

THE GIFT EVERY MAN NEEDS

ppd. Immediate Delivery Money Back Guarantee Used and recommended by Doctors as the one SAFE, easy way to remove unsightly hair from both nose and ears. Blunt end scissors can't cut or stick. Spoon shaped ends push flesh away from cutting edge. Curved blades permit cutting where needed. Prevents serious infection. Free catalog.

Arlene's, Dept. EL-21, 30 W. Washington St., Chicago 2, Ill.

YOUR SAVINGS EARN MORE INSURED

4 1/2%
Per Annum
Current period proposed rate

To \$20,000.00 per account by S.F.I.C. (U.S.A. Ins. Corp.)

Save with insured security... watch your account grow faster with high, high dividends. As convenient as your mailbox. Open your account now and receive FREE appreciation gifts—choice of Philco Portable TV, Transistor Radio, Portable Typewriter, Waltham Gold Watch, Detecto Scales, and other gifts. Write for Free Savings Kit including Account Opening Slips, Save-By-Mail envelopes and Gift Brochure. No obligation. Air Mail postage paid both ways.

FREE GIFTS
Write for Fast & Gift Brochure No cost or obligation

Dept. 1-A **PRUDENTIAL SAVINGS & Loan Assn.**
Prudential Bldg., 31 W. North Ave. Baltimore 1, Maryland

FREE!
Amazing New
VITAMINS
FOR FOLKS OVER 50!
Full 30 days Supply



New, safe scientific formula of high potency vitamins and minerals formulated specifically for folks over 50. No obligation to buy anything. Try at our risk to discover how it may help you enjoy healthier, happier living . . . free you from fatigue and worry . . . make you feel younger, peppier, more energetic. Send today for FREE 30-day supply of amazing OVER-FIFTY Capsulets and full information about amazing new OVER-FIFTY PLAN. Enclose 10c to help cover handling costs. Write Dept. 1812, Geriatric Pharmaceuticals, Inc., 179 N. Michigan Ave., Chicago 1, Ill.

DON'T QUIT SMOKING

... Before Giving My Pipe a Trial!

New principle that contradicts every idea you've ever had about pipe smoking. I guarantee it to smoke cool and mild hour after hour, day after day, without rest without bite, bitterness or sludge. To prove it, I'll let you try a new Carey Pipe. Send name today for my FREE complete trial offer. Write to: **E. A. CAREY**, 1920 Sunnyside Ave., Dept. 204-B, Chicago 40, Ill.

Improved EZO Helps Relieve Pain of Pressure and Slipping of FALSE TEETH
Chew in comfort with NEW, SOFTER EZO DENTAL CUSHIONS

Grips Dentures Firmer, Quicker!
 Helps Keep Seeds Out
 Helps Ease Pressure on Gums
 Helps Plate Fit Snug
 Helps Prevent Clicking



Ask for New EZO Heavy Gauge Cushions!

AT YOUR FAVORITE DRUG COUNTER 60c

Men: SLIM your appearance . . . relieve BACKSTRAIN



with new
Pi Peer
Cavalier

EXCLUSIVE new 3-way support in a single comfort-designed garment

Get a lift out of life! While wearing this revolutionary support you get these three important benefits: 1) your sagging stomach appears inches slimmer; 2) minor aches and pains caused by backstrain are relieved; 3) you get the suspensory comfort wanted by so many men! Wide-front elastic abdominal panel pulls in bulging stomach muscles . . . gives you that sleek, smart masculine profile women admire. No-gauge stays prevent wrinkling, rolling. Flat foam-rubber back pad, held firmly to body by a powerful, elastic back band, eases tired, aching muscles with firm yet gentle pressure. Special V reinforcing on sides shapes and stabilizes support over stomach, hips. Cool, mesh pouch snaps off for easy laundering. Easy to put on. Just put around waist and secure side fasteners. Only \$6.98 postpaid. Send hip measure. Satisfaction guaranteed or money back if support is returned in 30 days postpaid. Sold only by mail.



Piper Brace Co. Dept. EK-21Z
 811 Wyandotte St. Kansas City 5, Mo.

tonished Wade wound up 66 yards away in the end zone with a touchdown. The extra point made it Rams 7, Colts 3.

Ewbank stood stock still at this disaster. He slowly removed his cap and slapped it against his leg. It was his only angry gesture of a long and frustrating day. Seven weeks earlier, his Colts had easily beaten these same Rams in Baltimore by the respectable score of 31-17.

"Moore, get us some points!" snapped Ewbank at his ace runner. Lenny Moore, who has scored more than 300 Colt points in five seasons, had played superbly. He was dog-tired, but in he went to catch a pass on the Ram 35-yard line and then move the Colts to the 21 with another great catch.

"We go! We go!" the Colts on the bench chorused.

In flashed the 200-pound Ollie Matson to connect with a smashing tackle that left Moore groggy.

"Meanest hoe-down I've seen in a while," muttered Syzmanski, the line-backer, hunched next to me. A raw welt covered one of his cheekbones. I counted the casualties to date: the Rams had lost Frank Ryan (by now enroute to the hospital), plus Gene Brito, Del Shofner and Lou Michaels. For the Colts, Berry and Richardson were out, while Bob Boyd, Art Spinney and Marv Matuszak were walking around on their heels. One Colt coated with blood and dirt wandered past me, talking to himself. He tried to find the bench, and missed. He sprawled on the grass. No, indeed, you don't play this game just for money.

(Once, in fact, as Art Donovan, the 35-year-old four-time All Pro tackle, related, during a night game viciously played in a driving rain, a Colt rookie climbed under the bench, pulled a parka around him and remained in hiding for the duration of the war. He was, of course, released in the morning.)

Disaster mounted. The shaken Moore let the Rams intercept a pass in his hands. A Ram field goal followed, to make it 10-3.

The Rams, undebatably, were making their fiercest effort of the season. With 9 minutes to go, they had held Unitas to nine completed passes and no TDs, the Colts to less than 90 yards rushing. For once, the high scoring of the pros had compressed into a strictly defensive battle. And the fans weren't complaining. They were seeing football at its strategic best.

Even in desperation, the Colts never stopped thinking. The Rams held the ball midfield, fourth down and inches to go, when Big Daddy Lipscomb suddenly yelled, "Hut!"

Thinking their quarterback had called for the ball to be snapped, the Ram line charged offside. Despite yelps of protest, they were penalized five yards and

the ball went over to the Colts a play later.

It puzzled me when Les Richter, Ram defensive captain, called time out and grouped his team around him on the sideline for an unusual conference. Why? The answer—if it was a true one—came later.

Waterfield claimed to newspapermen that the Colts were stealing Richter's defensive signals—a most legitimate act in football—and that the Rams were forced to set up new signs from the fourth quarter on. "We made a fast adjustment and they didn't steal any more," said Waterfield.

Time was running out and no Colt drive had succeeded. I could sense defeat for the champs but it seemed they could not. With 3 minutes 45 seconds left on the clock, Unitas began throwing from his 3-yard line. He hit Alex Hawkins twice for 17 yards gained, Moore for 12 and 20 yards and Richardson for 23. He moved his team 76 improbable yards to the Ram 21-yard line. . . . The 80,000 Los Angeles fans were on their feet, fearing another patented Johnny Unitas finish.

Forty-five seconds left . . . the Coliseum in bedlam . . . the Colts lined up without a time-killing huddle.

Ewbank stood rock still on the sideline. "Just one more, Johnny," breathed big Syzmanski, next to me.

A hand-off was called—since the Rams were positive a pass was coming—and the black luck of December 11 didn't change for the Colts. Alex Hawkins fumbled Unitas's hand-off. The Rams' George Strugar fell on the bounding ball. It was all over. The Rams had won a stunning upset, 10-3.

As Unitas came off the field, his head low, Weeb Ewbank took him by both arms, got his chin up and spoke to him rapidly. Unitas responded slowly. Soon he was replying briskly. The two walked away at the sound of the gun, still comparing notes on what had happened to Baltimore.

"You learn more," Ewbank told me later, "by losing."

That's the Baltimore way. A good many thousands of dollars of championship game money had just slipped away from a team which has averaged four touchdowns a game, but couldn't get even one today—yet coach and quarterback already were picking up the pieces and building for the future upon them.

I sat a while on the littered, deserted bench. The bars of a face guard, ripped from a Colt helmet, lay at my feet. I looked at it again. The heavy bars were torn and twisted.

Quite a sport, the way the pros play it.

Just for the record, although Unitas's 47-game touchdown-passing streak was stopped, his last-period comeback had enabled him to break Sammy Baugh's all-time record. Unitas needed 182

yards to go past Slingin' Sam's 2,938-yard mark for yards gained in a season—and he got exactly 182 yards.

Back at the hotel that night, the Colts gathered in Art Donovan's room and I remarked to Johnny Unitas, "I

hope I didn't jinx you guys today."

Mr. Golden Arm could still smile, though it hurt.

"If I don't see you on the bench again," he said, politely, "I won't feel offended."

"Total Disarmament"

(Continued from page 13)

ground ahead. Bombers require this capability because they must navigate when all regular electronic navigational aids are turned off; airliners never fly when such aids are not operational.

Now that the Russians are allowing foreign airliners to fly through the Iron Curtain countries in exchange for *Aeroflot* flights abroad, free world pilots have found that the Soviet Air Force air raid detection system, and the control centers which direct defending fighter planes, have taken on the job of civilian air traffic control performed in America by the Federal Aviation Agency.

In the light of what the Germans are known to have done before World War II and the Russians appear to be doing now, key disarmament questions obviously are: *When is a state airline a commercial cargo and passenger service and when a bomber command? And, when is an organization a commercial air traffic control system and when an air defense command?*

The same sort of questions can be asked about rocketry: When have we a ballistic missile agency for war and when a space agency for the exploration and exploitation of space for peaceful purposes? The lead the Russians obtained in very powerful rocket motors has put them ahead in launching heavy loads into space for exploration, as well as affording them what many U. S. authorities believe to be a major initial lead in intercontinental missile armament for war. Contrary to general expectations when U. S. ballistic missile development began, this "doomsday-type" weapon is constantly proving to have more and more uses immediately, and immensely, for commerce and the average citizen. Ballistic missiles have proved that they can put into orbit satellites which can solve growing problems in weather prediction, telephone communications and ship and airplane navigation.

Thus the difference between a civilian space agency and a military missile command already has become difficult to define. Ingenuity in cheating on disarmament could easily make it well-nigh impossible to detect.

There is not a major nation in our lifetime that has not scored major creative "breakthroughs" in the scientific-military field—and not a major nation that has not had its blind spots. The British beat the world to radar. The Germans were relatively blind to atomic energy but had imagination for jet

planes, snorkel submarines and rocket bombs. America proved most imaginative about atomic energy, only to find, in 1957, that the Russians are as imaginative as we in the vital field of space.

No people have a monopoly on brains, which is another way of saying that even if all the conventional weapons of the world were destroyed tomorrow, someone would dream up *unconventional*, new weapons the next day. One of the real problems about "total disarmament" is that it could only succeed if there was "total inspection"—but to inspect successfully you have to know what you are looking for. History shows that people with conventional minds rarely guess what people with unconventional minds are up to. The long-range rocket and the atom bomb are recent and important examples of the fact that conventional military minds generally fail to grasp the importance of unconventional ideas for weapons.

Everyone knows that America was brilliant enough to accept Albert Einstein's suggestion to President Franklin D. Roosevelt that an atom bomb was possible; but what is forgotten is that before this one of Einstein's colleagues had suggested such a revolutionary bomb to the U. S. Navy and had been shown to the door. It was not so much the apparent face value of the atom bomb idea as the great weight Einstein's name carried that triggered FDR's acceptance of his suggestion. But for Einstein's prestige we might not have been first with this revolutionary new force.

Imagination is a strange quality. No country ever has an overabundance of it. While we and the British were using our imaginations about atomic energy, the Germans were more or less blind to it. But at exactly the same period, while the Germans were using their imagination about long-range rockets, we and the British were more or less blind to that! The V-2 rocket project was underway in Germany by 1932, but the first the British learned about, or even imagined, this fateful development was seven years later, in 1939, via the famous warning letter from an agent in Oslo. Even then, it was not until four years later, in 1943, that the British photographed the first V weapons and installations at Peenemunde—and this was only by luck. A Spitfire reconnaissance plane was on a mission

CORRECTING HEARING LOSS WITHOUT A HEARING AID

While the use of a hearing aid is the solution to many hearing problems, it isn't the only way to restore hearing. Facts about some types of hearing loss that can be corrected through medical treatment or by simple surgery are found in Zenith's booklet, "Hearing Loss and the Family Doctor," written by a nationally prominent physician and published by the Zenith Radio Corporation. To obtain a free copy of this valuable booklet, simply fill out the coupon below.

-----FREE BOOKLET-----

For your free copy of "Hearing Loss and the Family Doctor," plus descriptive literature on Zenith Hearing Aids, just write:

Zenith Radio Corporation, Dept. 270
6501 W. Grand Ave., Chicago 35, Ill

NAME _____

ADDRESS _____

CITY _____ ZONE _____ STATE _____

MARTIN'S FLAGS

★ ALL KINDS
★ ALL SIZES

DISPLAYS FOR ORGANIZATIONS-TOWNS-SCHOOLS-FAIRS

Prompt shipment. Ask for our colorful WHOLESALE Catalog No. 61-E

MARTIN'S FLAG CO., FORT DODGE, IOWA

Folding Tables . . .

QUICKLY FOLD OR UNFOLD!

Maximum Seating
Minimum Storage

PERFECTIONEERED

Better appearance, durability and strength. Finest construction, workmanship, finish. Choice of many top materials and colors. Write for Folder

Mitchell FOLD-O-LEG tables

MITCHELL MANUFACTURING CO.
Dept. G, Milwaukee 46, Wisc.

DON'T PULL HAIR FROM NOSE

May Cause Fatal Infection

Use the **HOLLIS KLIPETTE** Rotating Scissors

So Simple! Just turn end. Surplus hair comes out easily, gently.

You can cause serious infection by pulling hair from nose. Ordinary scissors are also dangerous and impracticable. No better way to remove hair from nose and ears than with KLIPETTE. Smooth, gentle, safe, efficient. Rounded points can't cut or prick skin.

\$1 made from fine surgical steel chromium plated

Guaranteed to Satisfy or Money Back

HOLLIS CO. • 1133 Broadway, New York 10, N. Y. • Dept. H-4
Enclosed is \$1.00 for KLIPETTE. If I am not entirely satisfied, I may return it within 10 days for refund.

Name _____ Address _____

MAKE UP TO \$1,000.00 IN A MONTH with Sensational New Longer Burning MERLITE LIGHT BULBS

**Amazing FREE REPLACEMENT GUARANTEE:
NEVER AGAIN BUY LIGHT BULBS!**



Averages \$12 an Hour
"The answer to a salesman's prayers...fantastically easy to sell. I'm working only part time and have averaged \$12 an hour."
Philip Smith, Maine

FREE! Write now for complete details of the biggest money-making opportunity in years. Everything FREE, no obligation.
MERLITE INDUSTRIES, INC., Dept. C-41B
(Bulb Div.) 114 E. 32nd Street, New York 16, N. Y.

20 Ferris NORTHERN GROWN EVERGREENS \$1

Four each of Colorado Blue Spruce, Douglas Fir, White Spruce, Norway Spruce and Ponderosa Pine. All 20 only \$1.00 postpaid. One to customer, please. Handsome, colorful 1961 Ferris Nursery Catalog FREE, 60 big pages. 92nd Anniversary Edition. Write for it.

EARL FERRIS NURSERY
381 Bridge St. Hampton, Iowa

earn as TAX EXPERT
\$15 HOUR

Our students earn as much as \$3,000 in 3 short months preparing income tax returns in spare time—also operate lucrative Busn. Tax Service yielding steady monthly fees of \$10-\$50 per client, year round. Enjoy professional standing in dignified home-office business. We train you at home and help you start. Write today for free literature. No agent will call. Approved by N.J. Dept. of Ed. **UNION INSTITUTE OF TAX TRAINING, Lakewood 12W, New Jersey.**

Learn FLOWER ARRANGING

FOR PLEASURE—please your friends and family with professional corsages, arrangements and floral designs.
FOR PROFIT—Prepare for tremendous money-making opportunities in the Floral Field full or part time. Or start your own profitable business.
Study and earn your certificate at home. Write today for FREE booklet "Opportunities in Floristry."
NATIONAL FLORAL INSTITUTE
11826 San Vicente Boulevard
Studio EL-21, Los Angeles 49, Calif.

PLAY RIGHT AWAY!
Even if You Don't Know a Note of Music Now

Now it's EASY to learn any instrument. No boring exercises. Start playing real pieces by notes right away. In spare time. No teacher. Few cents progress at home. 1,000,000 students! Write for FREE BOOK.
U. S. School of Music, Studio A1052, Port Washington, N. Y. No salesman will call. (Est. 1898.)

BUILD YOUR OWN BOAT RAMP

SEND ONLY \$1.00 COMPLETE PLANS AND PARK YOUR BOAT ON THE SHORE OR IN THE BOAT HOUSE THE EASY WAY

ARCO MFG. CO. Dept. ES GRAND FORKS, N.D.

Father Flanagan's BOYS TOWN CHOIR

MSGR. FRANCIS SCHMITT,
Director

Now Booking 1961 Tour
To West Coast

Write Msgr. Nicholas H. Wegner
Boys Town, Nebr.

to photograph Navy destroyers at nearby Warnemunde. By chance, the pilot turned on his cameras too soon and got on his film strip a few shots of the test stands at Peenemunde (the Nazi Cape Canaveral)—and for the first time a V-weapon was seen!

Now put together what has just been said. In 1939 in the Free World, Einstein, Fermi, Niels Bohr and others were saying (and proving) that an atomic warhead was feasible. At the same moment, in the Nazi world, the Germans were saying (and proving) that long-range ballistic missile rockets were practical and that there was no defense against them. In other words, each side had half the answer to an "ultimate" new weapon; each side had one eye open to its feasibility and one eye closed. In 1939 conventional American military men could not imagine that a long-range rocket with an atomic warhead was feasible; yet within ten years the U.S. and the Russians and the British had such a weapon.

There is another practical reason why Russia's call for "total disarmament" is disarmingly simple and falls apart when examined with care. There is one major power in the world today whom not even the Russians could trust—Red China—and yet serious disarmament is impossible without the complete cooperation of the Chinese, and Mao is hardly reassuring about that possibility. Nor is the recent Communist Manifesto charging the U.S. as the "chief enemy of the world's people" and simultaneously proposing a new Summit Conference, in any way encouraging.

So far we have mentioned Big Powers only. But there is another aspect to disarmament that becomes more important and more discouraging every day—the small powers' warlike rivalries and their increasing ability to start "brushfire" and perhaps nuclear war. What about Cuba, Yugoslavia, Indonesia, Egypt, the Congo? Some of them, at various times, seem to be more irresponsible than Russia. "Total disarmament," without equal disarmament by them, is impossible because they may soon have atomic weapons themselves. Until recently nuclear war, as a possibility, has been limited to the so-called "atomic club" of the U.S., Britain, Russia, France and possibly China. But now there are increasing indications it will soon be possible to manufacture "cheap" atomic bombs and that a dozen eventually have such arms and be capable of irresponsibly starting a nuclear war. The situation in the Congo is serious enough without putting atomic bombs into Congolese hands. Castro, with his own atomic power, would be an infinitely greater problem than he already is. Any deep disarmament would have to include the smaller nations as firmly as the larger ones—a

prospect that scarcely seems possible.

It is, in fact, precisely in their relations to these smaller and often newer nations that the Russians are proving how insincere their disarmament talk is. All the good work which the United States, through the Munitions Control Office of the State Department, has been doing to clamp down on selling arms to small countries is being constantly undone by the Red bloc, which has become the biggest arms peddler of modern times. Instead of the multimillionaire arms king, typified at the turn of the century by Sir Basil Zaharoff who stimulated arms races by selling to both sides, we now have an entire bloc of countries, led by Russia, Poland and Czechoslovakia, peddling arms to small nations all over the world.

If the Russians were really sincere in their desire for disarmament, they could not make a better beginning than to stop peddling arms and thereby building up rivalries and tensions. The record shows that the United States has worked effectively with the Organization of American States to limit the sale of our arms to Latin American countries and has the cooperation of our European allies in this disarmament program. As a result, the long hostility between Peru and Ecuador has been eased, for example, and, as the budget for arms in both countries has dropped, the average citizen there is eating better by day and sleeping more securely by night.

The communists, on the other hand, are selling arms irresponsibly in an obvious effort to stir up trouble from which the communist world can benefit. Not only are the Reds selling increasing quantities of arms to Cuba, but, using Cuba as a transfer point, they are trying to push small arms into the rest of Latin America. Recently, the United States was requested to send a carrier force to seal off Guatemala and Nicaragua from illicit arms smuggled in from Cuba. Cans of "shredded coconut" from Cuba have contained hand grenades instead. Rebels in Colombia's mountains have recently been captured carrying the latest rifles from communist Czechoslovakia.

The real munitions villains are not to be found in the West, but right behind the Iron Curtain. The arms peddlers aren't duPont or Lockheed, Vickers or Schneider-Creusot, but two famous arms factories—Skoda and ZB—in communist Czechoslovakia. Americans who fought in the last war will remember that ZB manufactured the great Mauser rifle used by the Germans and originated the famous Bren light machine guns used by the British.

Such sales do not suggest that the Reds really want to see a disarmed world. Since the factories that produce these arms are state-owned, it would obviously be easy for the Kremlin to take a practical step toward "total dis-

armament" by prohibiting the sale and export of arms. But while the communists talk about disarmament, they are in practice fomenting armaments around the world.

Another great problem standing in the way of large-scale disarmament is the need many nations have for armed forces to maintain internal security. America, Britain and Canada have been free nations, with freely elected governments, for so long that their citizens tend to forget that in most areas of the world governments are set up and kept in power by force of arms. Such is often the case in Latin America. It is how the Russian communists obtained power, and the Kremlin maintains it.

To do so, the communists require, in addition to their regular army, navy and air forces, what seems to Americans to be a fantastically large supplementary force. On the request of this writer, the U.S. Army has supplied the following up-to-date estimates of the manpower strength of Soviet bloc internal security forces:

Soviet Russian Internal Security Troops and Border Guards.....250,000 men
Soviet European Satellite Internal Security Troops and
Border Guards290,000 men
Total540,000 men

To put these figures in proportion, the entire U.S. Army has only 870,000 men today, and back in 1939, before World War II, the total strength of the U.S. Army (then including the Air Force) was just 187,111.

Now these Internal Security Forces of the Soviets aren't secret policemen or uniformed cops; they are organized and armed on the lines of regular military forces. They have tanks, artillery, signal and other type troops, and their own air force. The Soviet Internal Security Troops, called "Blue Hats" from the color of their cap tops, are organized in units as large as army divisions. Brigades (about one-third of a division) are stationed in each of Russia's 23 military districts. The Border Guards, or "Green Hats," are strung out along the frontiers in company-sized units backed by tanks and heavy units, but they can be grouped in major fighting units as they were for World War II. Together they constitute an elite force better armed and equipped than the regular forces: an elite guard which can be likened to Hitler's Armed SS Divisions. As the SS was for the Nazi Party, they are the safeguard of the Communist Party.

The Communist Party in Russia is itself an organization with formidable military potential. It now has, by the 1959 census, 7,622,255 members. It is subject to discipline stricter than required of any military force. One of the requirements for membership is ability to perform various military duties. Thus it can, and has, acted as a

military force and it now numbers among its members hundreds of thousands of seasoned military service veterans, plus tens of thousands of professionally military men loyal to it and not the army, navy or air force. It is backed by the *Komsomols*, young fanatics serving their apprenticeships as party members. They total some 32 million of military age who must individually do certain part-time and "do-it-yourself" military training to keep qualified for membership. All in all, the Communist Party, with its own hierarchy and loyalty to its own group rather than to the Russian nation, very much resembles the dread German officer corps that so often plunged Europe into wars the German people didn't want. And the *Komsomols* resemble the non-commissioned officer corps that was dependent on the professional officers, and as willing to obey their superior commands as so many well-trained dogs.

There is nothing like the Soviets' Internal Security Forces, Communist Party, and *Komsomols* outside the Iron Curtain. So long as these Red institutions exist, they constitute in themselves—even should there be no Soviet armed forces—a major military threat. For example, if the free world and the Soviets eliminated their normal armed forces by mutual disarmament agreement, then in Russia party members and *Komsomols* could take over internal security work temporarily from the security forces, freeing these elite forces for armed aggression. Disarmament and a highly-disciplined and organized one-party state like Russia are basically incompatible. You cannot have one with the other.

Moreover, it is difficult to imagine that the Soviet dictatorship would ever permit the degree of inspection that would be essential to insure serious mutual disarmament. Complete inspection is equivalent to a free press—which no communist system has ever tolerated. Complete inspection would reveal too much of what really goes on in the Red world; too many skeletons would be found in too many closets, too much dirt would be uncovered under too many rugs for the communists ever to allow inspectors free movement.

Free inspection, moreover, would impair the Russian capacity for bluffing the outside world—a capacity which is as deeply Russian as a communist. It was a Czar who frightened the British, for instance, at the turn of the century by announcing the construction of giant armored cruisers, more powerful than any ships the Royal Navy possessed. Building these monsters turned out to be more difficult than the Czar had thought. But that didn't stop the Russians of that day from trying to get the biggest effect out of their "heavy cruiser" program. They sent one

Now! Life Insurance Birth to Age 80

\$1000 First
30 Days
ONLY 25¢
Per Policy

**CASH FOR YOUR FINAL EXPENSES.
AVOID BEING A BURDEN TO YOUR FAMILY**

Introductory Offer. Answer these 9 questions on a plain piece of paper and mail with only 25c for 30 days' protection. Regular rate shown on policy.

Amounts usually issued without doctor examination.

Ages	Amount	Ages	Amount
0 to 15	\$1000	45 to 65	\$1000
15 to 45	2500	65 to 80	500

1. Print full name and address.
2. Date of birth?
3. Height? 3a. Weight?
4. Occupation, kind of work?
5. Race?
6. Beneficiary and relationship to you?
7. To your knowledge have you had heart, lung, diabetes, cancer, or chronic disease? Are you deformed, lost a hand, foot, eye?
8. State condition of health. What illness in past 5 years or rejection for insurance?
9. Amount desired, and sign your name.

NO AGENT WILL CALL

Actual policy will be mailed you direct from Home Office. You be the judge.

Mail to: **S. B. Hunt, President**
AMERICAN LIFE & ACCIDENT INSURANCE CO.
305 American Life Bldg., St. Louis 8, Mo.

**PENNIES • NICKELS • DIMES
COUNTS • STACKS • PACKAGES**

Clever time saver, used by all who have the tedious chore of counting and wrapping small change. Churches, stores, taverns, ETC. ONE COINWRAP will count, stack, and package rolls of 50c in PENNIES, \$2.00 in NICKELS, or \$5.00 in DIMES many times faster. Exclusive patented feature. Guaranteed, complete with instructions and FREE bank Wrappers.

POSTPAID \$1.00

STERLING HOUSE
Dania, Florida
P. O. Box 626-EK

ACCORDIONS UP TO 1/2 OFF!

Save up to 1/2 off retail prices of comparable accordions!

5-DAY FREE TRIAL

Buy Direct from world's Largest Dealer!
Compare our low Importer-to-You prices!
See how you save! Over 30 models—finest genuine Italian makes! New, easier terms! Bonus Gifts Free. Rush name and address for FREE Color Catalogs and Direct Importer-to-You prices. Write

Accordion Corporation of America
2003 W. Chicago Av., Dpt. K-21, Chicago 22

NO MONEY DOWN!

Florida HOME SITES
\$395

Lovely 1/4 acre sites in Central Florida hills, lake, grove area \$395, no money down, \$10 a month • Suburb of Ocala, high and dry • Roads, utilities • 22 miles to Gulf Coast • Fish, hunt • Invest or retire. FREE color folder • Write Dept. 612-E
Rainbow Park, Box 521, Ocala, Fla.

AD 59067Z(0)

**LOOK
for Rupture Help**

Try a Brooks Patented Air Cushion appliance. This marvelous invention for most forms of reducible rupture is GUARANTEED to bring YOU heavenly comfort and security—day and night—at work and at play—or it costs you NOTHING! Thousands happy. Light, neat-fitting. No hard pads or springs. For men, women, and children. Durable, cheap. Sent on trial to prove it. Not sold in stores. Beware of imitations. Write for Free Book on Rupture, no-risk trial order plan, and Proof of Results. Ready for you NOW!

BROOKS CO., 114-G State St., Marshall, Mich.



How I Started My Own Little Drive-In on a Shoestring and Made \$16,000 in One Year

Let me show you the secret of making money in a small place . . .



I'll show you how to make money out of even smallest diner or roadside stand—and I'll show you how to start on a "shoestring" the way I did. I'll show you how to attract the crowds and how to get the cash coming in within an hour after you open your doors for business. No matter where you live—small town or big city—there are money-making opportunities all around you, provided you get off on the right foot. The big thing to remember is this: Don't get into the restaurant business blindly and trust to luck to succeed. To make money, you've got to know what you're doing. And I am in a position to give you all the information you need to get off to a flying start. Give me a chance to prove it. Just send me your name for my Free Book "Making Money on Food". There is no charge for the book—now or at any other time—and no salesman will call. Send name on postcard today to Ken Kessler, SCHOOL OF RESTAURANT BUSINESS, 335 W. Madison Street, Dept. K-302, Chicago 6, Ill.

FREE! Your Own Shoe Store

EARN \$10 to \$30 per day in your own profitable cushion shoe business. Build valuable repeat business in full or spare time. No money needed. 140 styles, sizes 2½ to 22, AAA to EEEEE. Write for free sales kit.

BRONSON SHOE, Dept. K-2
710 W. Lake, Minneapolis, Minn.

REAL ESTATE
BE A BROKER

PAYS BIG! SEND FOR FREE, BIG, ILLUSTRATED CATALOG NOW! Graduates report making substantial incomes. Start and run your own business quickly. Men, women of all ages, learn easily. Course covers Sales, Property Management, Appraising, Loans, Mortgages, and related subjects. **STUDY AT HOME** or in classrooms in leading cities. Diploma awarded. Write TODAY for free book! No obligation. Approved for World War II and Korean Veterans

WEAVER SCHOOL OF REAL ESTATE (Est. 1936)
2020H Grand Avenue
Kansas City, Mo.

FREE BOOK TELLS HOW

FREE GUIDE Reveals 200 Ways to Make Extra Money

YOU can turn your spare hours into cash (\$25 to \$100 a week)! Ask for Free Subscription to Opportunity Magazine, nationwide guide to extra cash for millions of men and women. Contains hints, plans, hundreds of offers. No matter what your age, experience, or occupation—write TODAY for next 5 issues FREE. Send no money—just your name.

OPPORTUNITY, 850 N. Dearborn, Dept. 301, Chicago 10, Ill.

2 GENUINE COTTON TOWELS FREE

To make new friends we'll send anyone who mails us this ad together with 10¢ for postage and handling, two fine quality brand new genuine Cotton Towels. But order NOW before we run out of Cotton Towels. Limit—2 towels per family. No towels sent without ad and 10¢. Make wonderful gifts.

COTTON TOWELS, Dept. CT-128, Box 881, St. Louis, Mo.

Borrow BY MAIL
\$32.49 Per Month Repays \$600

Enjoy the things you want NOW with a confidence **Cash YOU WANT**

LOAN-by-MAIL—get any amount, \$100.00 to \$600.00. Pay back in small monthly installments to fit your paycheck. Take as long as 24 months. No co-makers. Everything private. No matter where you live, rush this coupon. Loan Order Blank mailed Free in plain envelope. No obligation. Act!

Amount of Loan	24 Monthly Payments
\$100	\$ 5.93
\$300	\$17.49
\$400	\$22.75
\$500	\$27.69
\$600	\$32.49

DIAL FINANCE CO., 410 Kilpatrick Bldg., DEPT. B-110 - OMAHA 2, NEBRASKA

NO AGENT WILL CALL

DIAL FINANCE CO., Dept. B-110
410 Kilpatrick Bldg., Omaha 2, Neb.
Please rush FREE Loan Order Blank.

NAME _____
ADDRESS _____
CITY _____ STATE _____
Amount you want to borrow \$ _____

of these ships, the *Rossia*, to the naval review at Spithead in honor of Queen Victoria's Jubilee. The British were goggle-eyed when they saw the remarkably thick armor belts and casements that protected the great new Russian cruiser. And so they might have remained if Admiral Bacon, then a midshipman commanding the visiting barge of one of the British Admirals, had not poked the "armor" of the "*Rossia*" with his penknife and discovered that it was wood. The Russians, not having had time to make all the required armor, had the bright idea of using hardwood laminates and, in

so doing, made the "armor" even thicker (why not?) than the steel that was later fitted to the "*Rossia's*" hull. Real inspection would also reveal the extent to which the Reds have pirated industrial secrets from the West. And it would reveal Russia's own great and genuine technical progress, thus reducing the chances that Russia would have to surpass us in the technological race. At every level and from every angle, "total disarmament" is a mirage. Khrushchev's honey-sounding proposals to date have no practical significance, except as propaganda that the communists—not NATO—want peace. • •

Play Cards with John R. Crawford

(Continued from page 45)

king had been put up, West would have had two trump tricks. Of course, if West's first play is the jack or queen, you naturally play the king from dummy; or if West shows out on the first round, you go up with the king and play a heart back, forcing East to split his honors. By playing the trump suit this way you may lose an unnecessary trick but you guarantee losing only one trump trick and insure making the slam. There is only a 5 per cent chance

that all four trumps are on your left, but at rubber bridge it would be a bad investment to take even that much risk when you can make a safety play. In duplicate, taking this slight chance is necessary because you are going to compare your score with other players sitting in your seat who play the same hand at the same contract. If the hearts break so that you can lose no trump tricks, making seven, you will get a very bad score if you employ the safety play and only make six. • •

SOCIABLE DUPLICATES

The following was written by Richard Frey, a top-ranking bridge expert who also is editor of the "Bulletin" of the ACBL—a most informative publication that is replete with news about happenings in bridge. THE ELKS MAGAZINE requested Mr. Frey to write this addenda because Mr. Crawford did not think it would be appropriate, for reasons of length, to introduce this supplementary information in his article.

ALTHOUGH duplicate bridge is the game that decides all the major contract bridge championships, it is not necessary to aim at dethroning John R. Crawford (who has won more than 5,000 master points by his tournament victories) in order to enjoy playing this fascinating form of contract. Indeed, there are literally thousands of clubs throughout the United States where players of average ability can enjoy competition against their equals—and against better players, too—all of whom are playing for the fun of the game. In clubs affiliated with the American Contract Bridge League, for example, cash prizes are not permitted and betting on the score is forbidden, just as it is in national tourneys. Here, for the price of a movie (or, in clubs that charge an annual membership fee

that may range from \$2 up, even less) you can enjoy an exciting evening of competition where everybody plays the same hands and the luck of the deal is eliminated. It is not necessary to be a member of the American Contract Bridge League to play in these games, although many who get the duplicate bug become members (at \$2 per year) in order to receive the monthly magazine (ACBL "Bulletin") and to register, without cost, the master points they may acquire. At present, the League has grown to 120,000 members, and although this roster includes the country's leading players—the Life Masters (300 or more master points, 30 of which must be won in national tournaments) who rank at the top of the game—it also includes many of the rank and file who have learned to get more out of this great social pastime by joining with friends in a weekly competition played in a club or in the homes of the various club members. (A copy of a directory of duplicate clubs affiliated with the American Contract Bridge League may be obtained free on request to ACBL, 33 West 60th Street, New York 23, N. Y. The ACBL does not accept memberships directly, and all applications should be made through your local affiliated club.) • •

DiMaggio Was A Risky Gamble

By **GEORGE WEISS**

FAMED NEW YORK YANKEES FRONT OFFICE FIGURE



WILLARD MULLIN

Joe DiMaggio was the best trade I ever made, and, surprisingly, it was a gamble at the time. To get him we had to give five of our top-farm players for an option to buy him for \$25,000. There were many who thought we had made a mistake.

Joe was a sensation in his second full year with the San Francisco club and there wasn't a club in the majors which wasn't interested in him. He hit .341, a point higher than his previous year, and he was barely out of his teens.

At the end of the 1934 season, though, he suffered a freakish accident and here the element of risk entered the picture. He was riding in one of those jitneys, a cab with a lot of seats jammed in, and sat in an awkward position for most of the ride. When he got out he heard a loud pop in his knee as he put his weight on it. He wound up being carried home and the other clubs lost interest in a hurry.

We had a top-notch scout on the West Coast, Bill Essick, who advised us he thought the injury would be only temporary. Would the San Francisco club permit us to have our own doctor examine him before making the decision on him? The answer was yes, and the

best medical man we could get for the job assured us that DiMaggio would be as good as new in a short time.

So we plunged and handed over Ted Norbert, Floyd Newkirk, Les Powers, Jim Densmore and Eddie Farrell.

Some had seen service in the majors and it looked as though we were stripping our new farm system at the time. But it all had a fairy-tale ending.

Joe DiMaggio not only was as good as new the next season but was better. He hit .398, his best mark in two decades in organized ball, swatted thirty-four homers, drove in 154 runs. The following spring he came to camp with the Newark Bears and left with the Yankees, to remain with them through 1951.

DiMaggio was the first \$100,000 salaried ball player in history and it was my biggest thrill to sign him to this figure after I had become general manager of the club.

Five years after we had made our five-for-one decision, we had the league's Most Valuable Player. DiMaggio went on to win it twice more, and was named to the Hall of Fame only four years after he had retired.

As interviewed by Harold Rosenthal.

HOME IMPORT BUSINESS

MEN... WOMEN... MAKE BIG PROFITS... Buy dazzling bargains abroad. Sell to friends, stores or mail order. New Drop Ship Plan puts you in *direct contact with overseas sources*—starts you full or spare time, without product investment or previous experience. Complete details FREE. Write today!

MELLINGER CO., Dept. T392
1717 Westwood, Los Angeles 24, Calif.

Translator Radio with battery \$3.22

17-Jewel Watch \$2.87

Derringer Pistol \$5.14

Tape Recorder with Mike \$13.50

... Plans show where you get bargains like these for big profit sales. **DO NOT ORDER FROM US**

OWN a BUSINESS

Earn \$8,750.00 Your First Year! Start part-time if employed. You'll be trained by a nearby dealer and at 5-day training school. As carpet-upholstery cleaning expert, you provide 6 services to multiply profits and customer satisfaction. No shop needed. Just 2 average jobs a day nets \$8,750 first year. We help build your business with 27 regular services. Send for FREE booklets. **DURACLEAN CO., 1-542 Duraclean Bldg., Deerfield, Ill.**

FALSE TEETH That Loosen Need Not Embarrass

Many wearers of false teeth have suffered real embarrassment because their plate dropped, slipped or wobbled at just the wrong time. Do not live in fear of this happening to you. Just sprinkle a little **FASTEETH**, the alkaline (non-acid) powder, on your plates. Holds false teeth more firmly, so they feel more comfortable. Does not sour. Checks "plate odor" (denture breath). Get **FASTEETH** at drug counters everywhere.

RUPTURE-EASER



Pat. No. 2606551

Right or left Side \$4.95

Double... \$5.95

No Fitting Required

A strong, form-fitting washable support for reducible inguinal hernia. Back lacing adjustable. Snaps up in front. Adjustable leg strap. Soft, flat groin pad. No steel or leather bands. Unexcelled for comfort. Also used as after operation support. For men, women, children. Mail orders give measure around the lowest part of the abdomen and state right, left side or double. We Prepay Postage except C.O.D.'s.

PIPER BRACE CO.
811 Wyandotte Dept. EK-21 Kansas City 5, Mo.

People 50 to 80 Tear Out This Ad

... and mail it today to find out how you can still apply for a \$1,000 life insurance policy to help take care of final expenses without burdening your family.

You handle the entire transaction by mail with **OLD AMERICAN** of **KANSAS CITY**. No obligation. No one will call on you!

Write today, simply giving your name, address and year of birth. Mail to Old American Insurance Co., 4900 Oak, Dept. L255M, Kansas City, Mo.

ELKS HOME WORKSHOP TIPS

Repair of Ornamental Molding

Treasured old frames often have damaged ornamentation. This ornate relief work is usually made of a mixture of glue and plaster, difficult to duplicate and shape. But if the part is not too intricate, the amateur can fill in gaps and patch chipped sections with auto body solder, a metallic paste sold at auto supply stores.

Clean dust and grease off the damaged molding. Apply body solder with a palette knife in roughly the desired mass and contour. Very thick parts should be applied in layers, each being allowed to set a short time.

Let the final application set for an hour or two until it is firm but still plastic. Use knives, hairpins, or other small tools to shape it, cleaning the tools in laquer thinner occasionally. To smooth the surface, rub it with a thinner-moistened finger. Let the repair dry hard; then gild or paint it.



Sawhorses

Among the many letters that arrive from readers, some now and then offer a fine Workshop suggestion or two. Here's one, received some time back, from W. F. Gifford of Orange, Calif.

How many times have you wished you had a good sawhorse to use in the shop? They can be used for more than

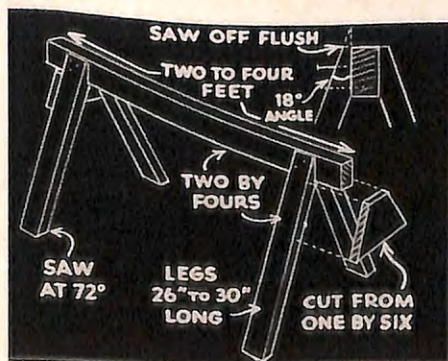

just sawing; they can serve as portable worktables, scaffolds for painting or repairing around the house, even as supports for the ping-pong or picnic table.

Good, strong sawhorses are easy to build, and you may have enough scrap lumber at hand to do the job without expense. In the illustrations, you will find dimensions that are generally used, but you can vary them, depending on their principal use.

The first version shown is easy to build, light, and two can be stored in the corner of the shop or garage by simply stacking one sawhorse on top of the other.

The second is of sturdier construction, has a supported top rail and is excellent for scaffolding where a really steady horse is needed. Lengthen the legs for use in supporting tables.

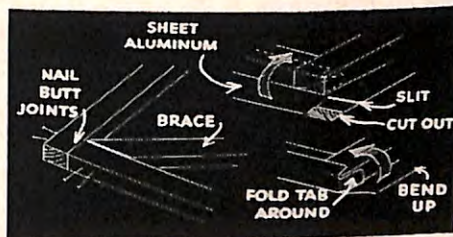

Wash Tub Covers

Many an older house has wash tubs from which the covers have disappeared. Becoming dirty, the uncovered tubs must be cleaned before each use.

A very light, strong and rustproof tub cover can be made of sheet aluminum, available at hardware stores. Build a simple wooden frame of one-by-two stock, using butt corner joints, rustproof nails and a diagonal brace.

Lay this frame on the aluminum, trim the metal to overlap the frame by 2" all around, and fold it around all four sides. Slit it at each corner, bend around the frame and fasten it with

rustproof tacks on the underside only.

A cleat or two nailed to the underside will retain the frame on the tub, but it can be hinged if you prefer.

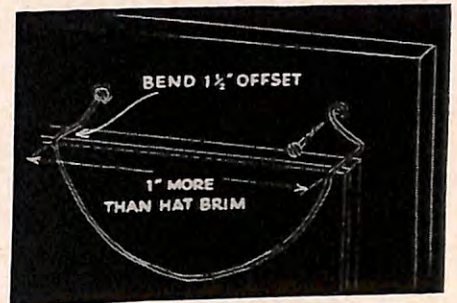

Hat Rack Inside Closet

Made from coat-hanger wire with no tool but pliers, a rack like this keeps a hat in better shape than it would be if kept on a jumbled shelf.

Shape the wire to a wide curve slightly more than half the hat diameter. Then bend out both ends at right angles, and bend short mounting lugs, again at right angles, as shown.

Attach the rack to the top rail inside a closet door, using either flathead wood screws or round-head screws and small washers. The hats must of course hang below the upper edge of the door, but should be above the shoulder line of hanging garments, where there is usually ample space.

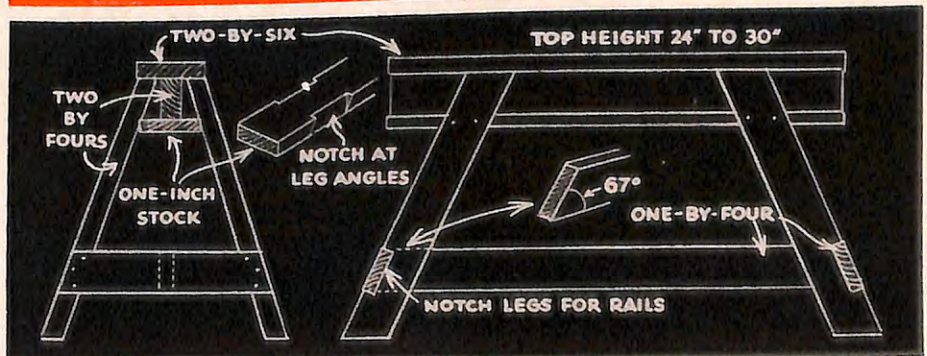
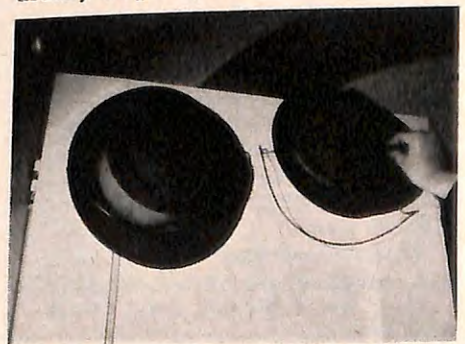

THE GIFT THAT LIVES

Prescription for a pleasant feeling: Turn to page 30 of this issue. Tear out enrollment form and fill it in. Make out check and insert in envelope. Seal and drop in mailbox.

Now you are a full-fledged member of the Elks National Foundation and entitled to enjoy the pride and satisfaction you will experience because you help make possible so many wonderful things for so many.

When you hear that the Foundation has made a substantial grant to your State Elks Association to assist its major charitable project, feel good about it. Your dollars made it possible, and will make it possible next year, the year after that and all the years ahead.

You can feel a little taller when you read about the neighbor girl who has received a Foundation grant so that she can learn how to teach children to overcome cerebral palsy. She's spending the income from that gift of yours to the Foundation.

You have often said that we can't afford to waste any talent if we're going to win the battle against communism. You were right, and you are doing something about it, because your gift to the Foundation is helping to send more than 300 American boys and girls to college every year. Maybe they wouldn't have made it without your help.

Grand Exalted Ruler Fenton is working hard to raise a million dollars for the Foundation this year. He said that he thinks every Elk will want to contribute if he has a chance, and that's why we inserted that envelope in the Magazine.

By the way, no part of your gift will be used to pay the cost of that envelope. The Grand Lodge pays all the expenses of the Foundation, so every penny of your gift will be used for Elk-sponsored benevolences all over America.

Another reason that makes your gift to the Foundation so satisfying and so sensible is that the Foundation does not spend any of its capital. It spends only its income, so that your dollars don't work just once, but will work forever producing dividends and interest that will be used year after year to educate bright and needy youngsters, to give crippled children a chance to live useful lives, and for all of the wonderful things that Elks are doing and will continue to do in the name of charity.

At the next lodge meeting, why not call attention to that envelope in this issue, under Good of the Order. Help your Brothers know the pleasant feeling that comes from having a share in the Great Heart of Elkdom with a gift that lives.

Elkdom Moves Ahead

It took 82 years for the membership of the Order of Elks to reach the one-million mark. That figure was attained in our anniversary month of February, 1950, when the millionth name was added to the circulation rolls of The Elks Magazine.

Eleven years later, with this issue of the Magazine, the Order's membership crosses the 1,300,000 level. That's a gain of 30%.

In 1950, there were 1,543 Elks Lodges. This month there are 1,943, a gain of 400 or 26%.

These gains are not spectacular, but rather indicate a steady, consistent growth that is healthy and symptomatic of the basic good health of the Order. They are even more impressive when it is remembered that they were made during a period marked by war, turmoil and varying economic fortunes.

Ninety-three years after its founding, the Order of Elks enjoys a secure place in American life because the principles of Elkdom—good fellowship, patriotism

and service to one's neighbors, especially those who are less fortunate—are just as appealing and just as needed in this space age as at any time in the past, if not more so. While adhering to these fundamentals, the Order of Elks has not stood still, but has kept pace with the changing times. Some of the change has been superficial, such as abandoning the regalia and other once-fashionable aspects of fraternities. But the important changes have been more significant.

Among them has been the development of family participation in our lodges' social activities, thus strengthening family ties. Another has been the tremendous expansion of Elks youth activities. Still another has been the remarkable spread of Elks programs for the rehabilitation of handicapped children—the cerebral palsied, the crippled, those with speech and eye defects, the retarded. The funds raised and spent by Elks for these merciful purposes are many times what they were a few years ago, and the time and labor that thousands of devoted Elks

pour into these projects are incalculable.

Elkdom will continue to move ahead so long as it remains a fraternity attractive to those men who, to paraphrase Shakespeare, value manhood, honesty and good fellowship.

Building Good Will

Elks youth programs are carried on to develop our youngsters in the right direction, and thus to build a better nation. It also happens that they are good for the Order. This was emphasized in a recent letter from William H. Haley, Youth Chairman of Elberton, Ga., Lodge with reference to the Elks National Foundation scholarship awards.

"We are also active in the Youth Leadership Contests, and always follow these up with a banquet for entrants and their families. This has done more to promote good will for our club than anything else," he wrote.

There are many lodges that do not participate in these programs. We urge them to heed Brother Haley's words.

* OFFICIAL ELK JEWELRY

A Gift That Will be Worn Proudly by Any Elk

For the lodge or the individual wanting to give an Elk a lasting gift that he will proudly wear here is the answer. Handsome jewelry officially approved by the Grand Lodge and distributed by The Elks Magazine. Prices include federal tax.



No. 1—50 year emblem. Beautiful, 10k gold with gold plated post and attaching button and five single cut sparkling 2-point genuine diamonds. Price \$78.85. A splendid gift to honored members or officers.
No. 1A—Same design, set with five blue sapphires. \$19.25.



No. 7E—Economic membership pin, without years designation, in 10k gold plate finish. \$4.00.

No. 7—Same design as above, in 10k solid gold, with gold plated post and attaching button. \$7.35.

No. 7S—Same as No. 7 but set with one 4-point genuine blue sapphire. \$11.00.

No. 7A—Same design with 2-point diamond. \$20.15.

No. 7B—Same design with 4-point full cut diamond. \$28.40.



No. 13—Past District Deputy Pin. Designed especially as a decoration for extraordinary services rendered to the Grand Lodge and beautifully suited to the honor which it indicates. 10k gold ornamentation surrounding red, white and blue, hard-fired brilliantly enameled Elks insignia. Gold plated attaching post and button. \$13.00.

No. 13A—Same as above, equally handsome but with one 5-point genuine blue sapphire inset at bottom. \$17.00.

No. 13B—Similar to No. 13 with addition of brilliant 5-point diamond inset. \$46.00.



No. 9—Life Member Pin. This new distinctive pin was specially designed and created for life memberships attained by reason other than Honorary award. 10k gold with gold plated attaching post and button, \$9.15.

No. 9A—Same design with two 3-point sapphires, \$13.75.

No. 9B—Same design with two 3-point diamonds, \$49.50.



No. 2—Plain 50 year membership pin with no jewel but brilliantly enameled red, white and blue. 10k gold with gold plated post and attaching button. \$11.00.



No. 11—Past Exalted Ruler pin. An emblem of rare beauty for one who has distinguished himself in his lodge and among his Brother members. Same craftsmanship that makes official Elk pins such fine examples of jeweler's art. Clock and pin beautifully enameled red, white and blue. Past Exalted Ruler designation gold letters on blue background. \$12.50.

No. 11A—Same as above pin No. 11 but with 5-point diamond. \$46.00.

No. 11B—Similar to 11 and 11A but jewel is a 10-point diamond. \$70.00.



No. 8—Honorary life membership pin. 10k gold, gold plated post and attaching button. \$9.15.

No. 8A—Same design with three 2-point blue sapphires. \$13.75.

No. 8B—Same design with three 2-point diamonds. \$49.50.



No. 10—30-year membership, plain with no jewels. 10k gold with gold plated post and attaching button. \$8.25.

No. 10A—Same pin, same quality as No. 10 but set with one 1½-point blue sapphire. \$9.90.

No. 10B—Similar to above, set one 1½-point diamond. \$19.00.



No. 3—25 year membership, plain (no jewels) 10k gold with gold plated post and attaching button. Handsomely enameled red, white and blue. \$8.25.

All Pins Manufactured By L. G. Balfour Co., one of America's Leading Manufacturing Jewelers

THE ELKS MAGAZINE

386 Fourth Ave., New York 16, N. Y.

Enclosed is check for \$..... for emblem

Button No..... Quantity.....

Name.....

Street.....

City..... State.....

On N. Y. C. orders please add 3% Sales Tax.

* Registered designs of the B.P.O.E.

TM and © applied for.

SAVE UP TO 1/2 on RUGS and wall-to-wall CARPETING

Cut Out and Mail
Coupon Below for

FREE
RUG & CARPET
DECORATING
BOOK

49 Model Rooms
**NO STAMP
NEEDED**

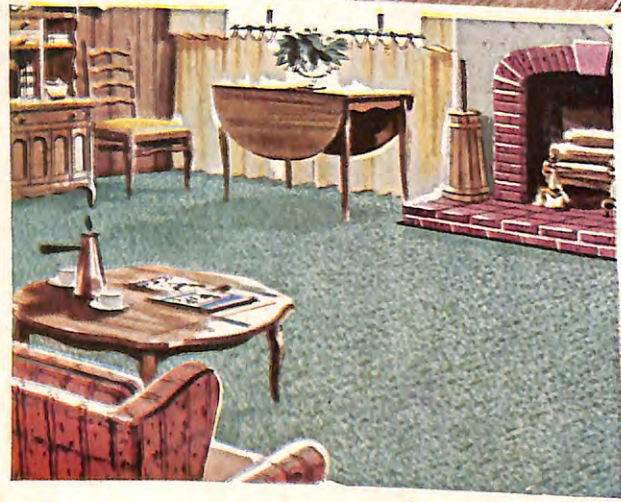

Direct from Olson Factory to You



Like Millions of Customers, you can beautify your home inexpensively with luxurious, longer wearing, two-sided Olson Broadloom Rugs and Wall-to-Wall Carpeting. The Olson "Magic" Plan is Simple—Easy—Fascinating.
Walter E. Olson, Pres.

**The Valuable Materials In Your Old Rugs—Or Carpets
—Or Clothing Can Help You Save Up To 1/2.**

By the Famous Olson Process, the good, seasoned materials in customers' discarded carpets, rugs, clothing are scientifically reclaimed like new, sterilized, bleached, merged, re-dyed—then re-spun with choice new materials and woven **In A Week** into the loveliest new deep-textured, *permanently Moth-Proofed* Reversible Broadloom Rugs or Carpeting you have ever seen for so little money. If you *wish*, you can send materials *after* your new rugs arrive.

Little as \$5 Down—up to 2 years to pay!

You Risk Nothing by a Trial. We guarantee to please you or pay for your materials. Our 87th year. Save direct from factory. We pay Freight (Rail or Truck) or Express on old material.

CUT OUT AND MAIL TODAY
(NO STAMP NEEDED — JUST DROP IN MAIL BOX)

Rush "Business Reply" coupon. Just cut along red dotted line, write your name and address and drop in any mail box. Pay no attention to printing on back. You'll receive beautiful Olson Rug, Decorating book Free, Gift Coupon.

CHOICE of 44 Decorator Colors, Patterns. Any size in a week, up to 18 feet wide, seamless in any length. Only Olson has looms in 19 widths. No wasted yardage to pay for.

Lovely TWEEDS	Modern Casuals
Solid Colors	Florals
Textured Effects	Scrolls
Early American	Ovals
Oriental Designs	

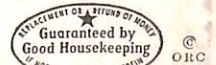

"we used them and like them!"

Write Your Name and Address—Cut Out and Mail Today

FROM:—

YOUR NAME.....
ADDRESS.....
TOWN..... STATE.....

FIRST CLASS
Permit No. 66
Chicago, Ill.

BUSINESS REPLY MAIL
NO POSTAGE STAMP NECESSARY IF MAILED IN THE UNITED STATES

6¢ Postage Will Be Paid By—

OLSON RUG CO. Dept. A-32

2800 N. Pulaski Rd., Chicago 41, Illinois

OLSON RUG CO.
Carpets

CHICAGO, 41 • NEW YORK, 1 • SAN FRANCISCO, 8