

# THE ELKS

MAGAZINE

MAY 1959



# \* OFFICIAL ELK JEWELRY

***A Gift That Will be Worn Proudly by Any Elk***

For the lodge or the individual wanting to give an Elk a lasting gift that he will proudly wear here is the answer. Handsome jewelry officially approved by the Grand Lodge and distributed by The Elks Magazine. Prices include federal tax.



No. 1—50 year emblem. Beautiful, 10k gold with gold plated post and attaching button and five single cut sparkling 2-point genuine diamonds. Price \$78.85. A splendid gift to honored members or officers.  
No. 1A—Same design, set with five blue sapphires. \$19.25.



No. 7E—Economic membership pin, without years designation, in 10k gold plate finish. \$4.00.

No. 7—Same design as above, in 10k solid gold, with gold plated post and attaching button. \$7.35.

No. 7S—Same as No. 7 but set with one 4-point genuine blue sapphire. \$11.00.

No. 7A—Same design with 2-point diamond. \$20.15.

No. 7B—Same design with 4-point full cut diamond. \$28.40.



No. 13—Past District Deputy Pin. Designed especially as a decoration for extraordinary services rendered to the Grand Lodge and beautifully suited to the honor which it indicates. 10k gold ornamentation surrounding red, white and blue, hard-fired brilliantly enameled Elks insignia. Gold plated attaching post and button. \$13.00.

No. 13A—Same as above, equally handsome but with one 5-point genuine blue sapphire inset at bottom. \$17.00.

No. 13B—Similar to No. 13 with addition of brilliant 5-point diamond inset. \$46.00.



No. 9—Life membership. Design similar to No. 8 but with word Honorary omitted. Same fine construction and enameling. \$9.15.

No. 9A—Exactly like life membership pin shown above but with three 2-point blue sapphires. \$13.75.

No. 9B—Same as No. 9. With three 2-point diamonds. \$49.50.



No. 2—Plain 50 year membership pin with no jewel but brilliantly enameled red, white and blue. 10k gold with gold plated post and attaching button. \$11.00.



No. 11—Past Exalted Ruler pin. An emblem of rare beauty for one who has distinguished himself in his lodge and among his Brother members. Same craftsmanship that makes official Elk pins such fine examples of jeweler's art. Clock and pin beautifully enameled red, white and blue. Past Exalted Ruler designation gold letters on blue background. \$12.50.

No. 11A—Same as above pin No. 11 but with 5-point diamond. \$46.00.

No. 11B—Similar to 11 and 11A but jewel is a 10-point diamond. \$70.00.



No. 8—Honorary life membership pin. 10k gold, gold plated post and attaching button. \$9.15.

No. 8A—Same design with three 2-point blue sapphires. \$13.75.

No. 8B—Same design with three 2-point diamonds. \$49.50.



No. 10—30-year membership, plain with no jewels. 10k gold with gold plated post and attaching button. \$8.25.

No. 10A—Same pin, same quality as No. 10 but set with one 1½-point blue sapphire. \$9.90.

No. 10B—Similar to above, set one 1½-point diamond. \$19.00.



No. 3—25 year membership, plain (no jewels) 10k gold with gold plated post and attaching button. Handsomely enameled red, white and blue. \$8.25.

All Pins Manufactured By L. G. Balfour Co., one of America's Leading Manufacturing Jewelers

## THE ELKS MAGAZINE

386 Fourth Ave., New York 16, N. Y.

Enclosed is check for \$..... for emblem

Button No..... Quantity.....

Name.....

Street.....

City..... State.....

On N. Y. C. orders please add 3% Sales Tax.

\* Registered designs of the B.P.O.E.

TM and © applied for.

# How I Turned \$1,000 into a Million

## --starting in my spare time

### AN AMAZING STORY THAT MAY CHANGE YOUR LIFE



by William Nickerson

PERHAPS the hardest thing about making a million dollars — or even \$200,000 — is the act of believing it to be possible. This may be the stumbling block which will keep you from seizing upon the extraordinary opportunity presented here.

Out of every thousand people who read this page, perhaps only 10 will be able to overcome their ingrained skepticism enough to send away for more information. And out of those ten, perhaps only one or two will exploit this opportunity to the hilt. But those fortunate few may enjoy the kind of financial success that millions dream of but only a few achieve.

You can pyramid personal savings of \$2,500 (\$50 a month, plus interest, for 4 years) into an estate worth \$219,972 in 14 years... \$1,187,295 in 20 years.

Your chances for success are better than 400 to 1 — in fact, 1600 times better than if you went into business — according to actual U.S. government statistics.

And most, if not all, of your new wealth will be yours to keep tax-free — not even subject to capital gains tax!

I did better than that. When I was 25, my wife Lucille and I started saving part of my first modest earnings as a telephone company employee. In three years we had saved the down payment to buy a home. I began looking about for a way to insure a modest retirement income to supplement my telephone company pension.

#### From "Scratch" to \$500,000 by 42

Starting with only the \$1000 cash equity in my home, I pyramided this modest asset into \$500,000 by the time I was 42 — all in my spare time. I retired at 42 to concentrate on my investments — with considerable time for gardening, swimming in our backyard pool, hunting, fishing, and traveling.

Many friends turned to me for advice on how they could follow me up the road to fortune. Finally I decided to write a unique guidebook, in which I would share my money-making secrets.

But editors who read my first manuscript told me: "Ah, but your success depended on starting during the depression. It could never happen again!"

#### Another \$500,000 in Only 2 Years

This led me to study other men's money-making experiences, and current, non-depression-period opportunities. Although I had not intended to increase my holdings, I found so many opportunities that in 2 years I doubled my estate to over \$1,000,000.

Now my book, HOW I TURNED \$1000 INTO A MILLION, is ready at last. And in

it I reveal — and tell how to use — these 4 basic principles of traveling the last remaining road to great fortune still open to the average person:

**1. How to harness the secret force of free enterprise — the pyramiding power of borrowed money.** If you have ever experienced difficulty in arranging a personal loan (or a commercial loan to go into business) you may have the idea that banks won't lend money to the "little fellow" for the purpose of making money. But I will show you how you can get lenders to put up gladly at least three dollars for every one of yours, thereby quadrupling the earning power of your capital.

**2. How to choose income-producing multiple dwellings in which to invest your own (and your borrowed) capital.** If you are interested in investing in income-producing property for income alone, then you will probably get along all right without any advice from me, although even there I can give you many tips. But if you are out to pyramid your capital, there is a definite set of conditions to look for.

**3. How to make your equity grow.** A fair market value of an income-producing property is in ratio to its income. Therefore, if you increase the annual net by means of the steps I outline, you increase the market value of the property — thereby increasing your equity.

**4. How to virtually eliminate the "tax bite" on your capital growth.** I will show you how you can increase your net worth steadily without its being subject to income taxes — not even capital gains tax! J. K. Lasser's famous guide, YOUR INCOME TAX, says of this method that "the mathematics have almost unparalleled attraction."

If you have about \$2500 right now — or if you can save only \$50 a month for the next four years — you can start out soundly along the road to a million dollars. To enhance your progress you will need an additional personal investment of \$50 a month, or \$600 a year, for two more years after that, making a total investment from your personal savings of \$3600. But then you will start receiving income from your investment. In addition, if you follow my instructions carefully, your capital can grow at the following startling rate:

- In 2 years, your \$3600 grows to \$5,800.
- In 4 years, you have \$11,575.
- In 6 years, \$21,681.
- In 8 years, \$39,363.
- In 10 years, \$70,548.
- In 12 years, \$124,884.
- In 14 years, \$219,972.
- In 16 years, \$386,376.
- In 18 years, \$677,583.
- In 20 years, \$1,187,195.

How far you want to go up this ladder depends on how much retirement income you would like. You can conservatively expect to earn an average net return of 6%

on your personal equity. So, if you would be satisfied with a retirement income of at least \$12,000 a year, you might decide to stop when your equity reaches \$200,000.

#### "There Must Be a Catch to It!"

Right now, it would be understandable if you were sputtering, "But — but — it's not that simple. There *must* be a catch to it!"

Of course there's a catch to it! There are hundreds of "catches" — hundreds of pitfalls and traps for the unwary who have never traveled what I call the "realty road to riches." But I made it, by learning as I went along. And you have a priceless advantage which I never had — the advantage of being able to know beforehand everything I had to learn by trial-and-error.

My 497-page book is literally the product of a lifetime, into which I have poured every distilled ounce of practical knowledge I gained along the road to fortune. It answers all the questions on real estate operations that my friends have ever asked me. I lead you through one actual transaction after another, setting forth each step in detail.

This method of making money is *not* dependent on continued economic boom or inflation. It is benefited and underwritten by America's continuing population boom, which is expected to result in 77 million more people by 1980. And it is comparatively recession-proof.

#### Read Book for 2 Weeks Free — Then Decide

You may have other questions, other doubts. Rather than attempt to answer them all here, the publishers invite you to examine my book free for two weeks in your own home. If you're not impressed, return the book in two weeks and pay nothing, owe nothing. Otherwise it's yours to keep for only \$4.95 plus a few cents postage. Mail coupon or write to: SIMON AND SCHUSTER, Publishers, Dept. 61, 630 Fifth Avenue, New York 20, N. Y.

To Your Bookseller, or  
**SIMON AND SCHUSTER, Publishers,  
Dept. 61  
630 Fifth Avenue, New York 20, N. Y.**

Please send me William Nickerson's 497-page book, HOW I TURNED \$1000 INTO A MILLION, for two weeks' free examination. If not convinced that this book can pay for itself literally thousands of times over, I may return it in 14 days and pay nothing. Otherwise I will keep it and remit only \$4.95 plus a few cents postage as payment in full.

Name.....  
(PLEASE PRINT)

Address.....

City..... Zone... State.....

**SAVE POSTAGE.** Check here if you prefer to enclose \$4.95 WITH this coupon. Then WE prepay all postage charges. Same 14-day return privilege, full refund guaranteed.

# THE *Elks* MAGAZINE

VOL. 37 NO. 12

MAY 1959

NATIONAL PUBLICATION OF THE BENEVOLENT AND PROTECTIVE ORDER OF ELKS OF THE UNITED STATES OF AMERICA. PUBLISHED UNDER THE DIRECTION OF THE GRAND LODGE BY THE NATIONAL MEMORIAL AND PUBLICATION COMMISSION.

**THE ELKS NATIONAL MEMORIAL AND PUBLICATION COMMISSION**

**JOHN S. McCLELLAND** Chairman  
**JAMES T. HALLINAN** Treasurer  
**EMMETT T. ANDERSON** Vice-Chairman  
**EARL E. JAMES** Assistant Secretary and Assistant Treasurer  
**WADE H. KEPNER** Secretary

**JAMES R. NICHOLSON**  
General Manager

**LEE C. HICKEY**  
Editor

**REGINA M. FISHER**  
Associate Editor

**WILLIAM O. CHESSMAN**  
Art Director

**ROBERT ELMAN**  
Assistant Editor

**GENEVIEVE G. CONOVER**  
Advertising Production

**W. H. MAGRATH**  
Controller

**JOHN SCHMITT**  
Circulation Manager

**ARTHUR J. GROSSBARD**  
Promotion Manager

EDITORIAL OFFICES, 386 Fourth Avenue, New York 16, N. Y.

Cover Painting.....	WILLIAM JOHNSON	
Greetings to Elks at the 1959 Convention.....		4
Change of Pace.....	DONALD HONIG	6
Rod and Gun.....	TED TRUEBLOOD	8
Home Again!—A Message from the Grand Exalted Ruler.....		9
Fastest Growing Sport.....	PHIL REAVIS	10
When Big Business Moves to Town.....	DICKSON HARTWELL	12
For Elks Who Travel.....	HORACE SUTTON	14
Lodge Visits of Horace R. Wisely.....		16
“Power for Peace”— Elks National Service Commission.....		19
News of the Lodges.....		20
Tom Wrigley Writes from Washington.....		27
In the Dog House.....	ED FAUST	28
Letters from Our Readers.....		29
Elks Family Shopper.....		30
Travelguide.....		38
Elks National Foundation—“The Joy of Giving”.....		46
Freedom’s Facts.....		52
Elks Home Workshop.....	HARRY WALTON	54
THE ELKS MAGAZINE Editorials.....		56



**ADVERTISING OFFICES**



**CHICAGO 1**  
360 North Michigan Avenue  
STATE 2-6662

**NEW YORK 16**  
386 Fourth Avenue  
MURRAY HILL 4-5495

**LOS ANGELES 17**  
1709 West 8th Street  
HUBBARD 3-0633

**SAN FRANCISCO 4**  
511 Merchants Exchange Building  
465 California Street

**PORTLAND 4, ORE.**  
217 Times Building  
CAPITOL 7-3718

**POSTMASTER: Send notices concerning addresses to:  
THE ELKS MAGAZINE, 386 Fourth Avenue, New York 16, N. Y.**

Members are asked, in changing address, to send this information (1) Name; (2) Lodge number; (3) Membership number; (4) New address; (5) Old address. Please allow 30 days for a change of address to be effected. THE ELKS MAGAZINE, Volume 37, No. 12, May, 1959. Published monthly at McCall Street, Dayton, Ohio, by the Benevolent and Protective Order of Elks of the United States of America. Entered as second class matter November 2, 1940, at the Post Office at Dayton, Ohio, under the Act of August 24, 1912. Acceptance for mailing at special rate of postage provided for in Section 1102, Act of October 3, 1917, authorized May 20, 1922. Printed in Dayton, Ohio, U.S.A. Single copy price, 20 cents. Subscription price in the United States and its Possessions, for Elks \$1.00 a year; for non-Elks, \$2.00 a year; for Canadian postage, add 50 cents a year; for foreign postage, add \$1.00 a year. Subscriptions are payable in advance. Manuscripts must be typewritten and accompanied by sufficient postage for their return via first class mail. They will be handled with care but this Magazine assumes no responsibility for their safety. Copyright, 1959, by the Benevolent and Protective Order of Elks of the United States of America

Here's a unique opportunity...

## own a high-profit second business that runs itself!

**Open a Philco-Bendix Self-Service Laundry Store!** Many store owners, executives, professional people—businessmen of all kinds—are going into the self-service laundry business. The reasons are obvious. Many of these new-type laundry stores are delivering a 25% return on a small capital investment.

**Here are some of the facts:** The coin-operated laundry business is one of the fastest-growing businesses in the country. Customers simply come into the store, wash and dry their clothes in metered machines and leave.

**Minimum supervision required.** A coin-operated laundry needs no attendant. Only a couple of hours a week are required to empty the coin boxes and supervise efficient operation. There are no credit problems—strictly a cash business. Machine repair and daily maintenance can be contracted to local people. An owner can spend full time with his regular business or practice and let the coin store run itself.

**Why are they so successful?** Philco-Bendix coin-operated laundry stores offer a customer up to 65% saving over attended-type wash-and-dry service. They are convenient for busy people because they remain open 24 hours a day, seven days a week. They give customers a chance to do their own washing—their own way.

**Small initial investment.** The cost of opening one of these stores equipped with Philco-Bendix Commercial Washers, the only complete line of commercial washers engineered for coin use, is surprisingly low. Only a small initial investment is required. The balance may be financed through Philco Finance Corporation. Return is so rapid that many investors amortize the total cost within a year.

**Act now!** Investigate this exciting business opportunity today! Send the coupon for full data on business locations in your area and help in all phases of planning, financing and promoting a successful coin store.



**COMMERCIAL LAUNDRY SALES**

Philco-Bendix Commercial Laundry Equipment is brought to you by Philco Corporation.

**PHILCO CORPORATION**

Commercial Laundry Adv. Dept. E-2  
Tioga and C Streets, Philadelphia 34, Pa.

Please send me information right away on Philco-Bendix Commercial Laundry Equipment, also the name of my local distributor.

Name \_\_\_\_\_  
 Address \_\_\_\_\_  
 City \_\_\_\_\_ Zone \_\_\_\_\_ State \_\_\_\_\_



# How much do you really know about Diet and Exercise?

ANSWERING THE PUBLIC'S MOST REPEATED QUESTIONS ON FOOD, ENERGY AND VITALITY

## What is the relationship between diet, exercise and vitality?

*Diet* is the amount of minerals, vitamins, protein, carbohydrates and fat consumed each day, in other words, it's the amount of gasoline that goes into the tank. *Exercise* is the accelerator that helps convert a greater amount of your daily diet into energy than you ordinarily convert while sitting, standing, walking, doing light household, gardening, office, or shop work, or while playing mild games such as golf, bowling, and so on. *The conversion of more food and oxygen into energy by exercise is what builds up your vitality.*

## What constitutes vitality?

Vitality is the vigor you exert when you work, play, lift, heave, haul, run, bend, sing, prance, think, talk or dance. It indicates the measure of your capacity to endure physical stress and strain or emotional shock and pain. Vitality is to the human system what horsepower is to an engine — it rates your power to perform.

## What about so-called energy foods?

Foodstuffs, whether in natural or concentrated form, are only a potential source of energy like gasoline is a potential source of power. But food itself is not energy! You cannot eat or drink energy. *Energy is the power you exert when your muscles go into action.*

## What is meant by muscle tone?

The *tonus* of muscle tissue rates its ability to contract and expand when you want to perform any physical task. The more you exercise your muscles, the stronger, firmer and more flexible they become. This is what is meant by muscle tone. You move, eat, talk and express yourself with the help of muscles. They activate the heart, arteries, capillaries and veins. They manipulate the bones. All body cells depend on muscle power for food, oxygen and the elimination of waste. *It's impossible to remain in a top-notch physical condition without good muscle tone.*

## What constitutes youthfulness?

Youthfulness is a measurement of your physiological age as compared to your calendar age. You either reflect your calendar age, look, feel and act much younger, or you look, feel and act much older. *Any healthy adult out of condition can become more youthful by exercising more each day.*



## What form of exercise is best?

For healthy people, *ALL-OUT* exercise! This means any sustained activity that exercises most of the major upper and lower body muscles in unison, and at a rapid clip, such as running, vigorous swimming, a fast game of handball or

tennis, and so on. *ALL-OUT* exercise circulates a greater amount of blood, converts a greater amount of food and oxygen into energy, and builds up a greater amount of vitality. *ALL-OUT* exercise is the fountain from which more youthfulness flows!

## How long should All-Out exercise continue?

A healthy person doing sedentary work in the home, office, shop or factory should do *ALL-OUT* exercise for 30 minutes or longer, each day.



## I'm out of condition. How can I do All-Out exercises?

Use an Electric Exercycle so you can do *ALL-OUT* exercises from the very beginning without having to move your body weight yourself. Otherwise it may be months or years before you can do *ALL-OUT* exercises. The Electric Exercycle cuts exercising time from hours to minutes. For beginners, it eliminates stress, strain and pain. You can use it at home and at any convenient time. *It offers the easiest, safest, cheapest and quickest way to get yourself back into good physical shape.*

## Do doctors ever recommend the Exercycle?

Oh, yes! In fact, not only have many doctors recommended the Electric Exercycle to their friends and patients, but thousands of doctors have bought an Exercycle for personal use.

## Who sells the Exercycle?

The Electric Exercycle is sold by representatives specially trained in the physiology of exercise, capable of answering additional questions on this subject. Mail the coupon below for FREE Exercycle literature.

**This literature is Free! Send for it.**

Physical Fitness Department  
Exercycle Corporation  
630 Third Avenue, New York 17, N. Y.

- Send me FREE Exercycle literature and prices.
- I want a FREE home demonstration.

Mr. \_\_\_\_\_  
Mrs. \_\_\_\_\_  
Miss \_\_\_\_\_ (PLEASE PRINT)

Address \_\_\_\_\_

City \_\_\_\_\_ Zone \_\_\_\_\_ State \_\_\_\_\_

Telephone \_\_\_\_\_

Copyright 1959, Exercycle Corporation. "Exercycle". Trade Mark Registered

# GREETINGS

## TO BROTHER ELKS AND THEIR FAMILIES



*Dear Brother Elks Everywhere:*

Your Brothers of Illinois are happy to welcome you again to a great city and a great state. Elks and their families who have visited Chicago before will find significant improvements in our city and its environs. First-time visitors will find a city of friendly people eager to make their stay pleasant and interesting.

We hope you will take advantage of the opportunity to visit our art galleries, museums, planetarium, aquarium, zoo and the many other places provided for the entertainment and education of residents and visitors. We urge you particularly to visit the beautiful Elks National Memorial Building, world famous for its murals and statuary.

Chicago is proud of its great universities and colleges, its churches of every denomination, its many hospitals, its beautiful parks and its famous buildings and you will find it to your interest and profit to visit them. Some of these are conveniently located in the downtown section within easy walking distance from the principal hotels and others are readily reached by public transportation.

You will like Chicago. The Elks of Illinois want you and your families to come and enjoy it for the week of our 1959 reunion. We are planning to make your stay so pleasant you will want to linger awhile and then come again.

Fraternally yours,

PAST GRAND EXALTED RULER

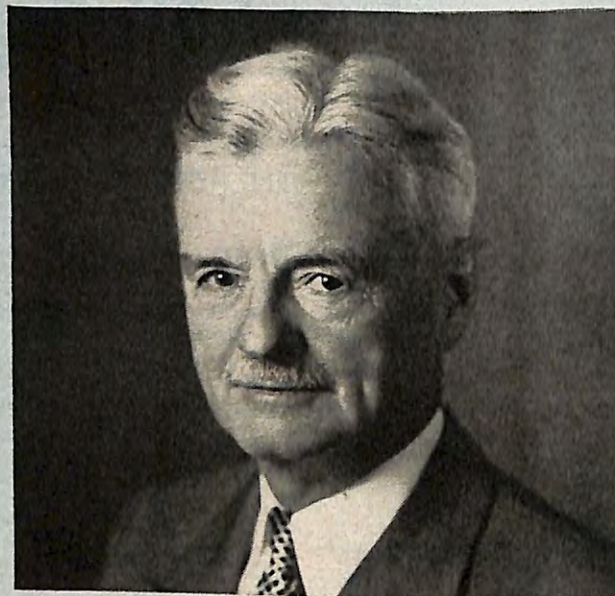

*To all of my Brother Elks:—*

We invite you to come to Chicago for the 1959 Elks National Convention July 5th to July 9th. The Convention Committee has planned much that will be of interest and instruction. All sessions of the Grand Lodge will be held in the air conditioned Convention Hall of the Conrad Hilton Hotel, the largest hotel in the world. An excellent program of entertainment is being arranged for the ladies.

Chicago has had wonderful experience in entertaining visitors and making its convention guests feel at home. It has unexcelled facilities for accommodating and entertaining guests. Of special interest to Elks is our beautiful National Memorial Building.

Illinois' marvelous system of highways and toll roads makes Chicago easily accessible by motor and its railroad service is ample.

The environment of the convention will be an inspiration to greater effort and more outstanding accomplishments. Elks Grand Lodge Conventions are noted for businesslike administration of the affairs of the Order and we have demonstrated our ability for a wholesome enjoyment of life.

May we extend to all of the Elks, their families and their friends, a warm and cordial invitation to attend this convention; 65,000 loyal Illinois Elks welcome you. We hope to make it a memorable event.

Cordially and fraternally,

PAST GRAND EXALTED RULER

Just Imported:

# THE FISH LURE GUARANTEED TO CATCH FISH! OR IT COSTS YOU NOTHING!

Works in Lakes, Ponds, Streams, Salt Water. Saves You Time, Work, Money and Disappointment. Perfect for Amateurs, Experts, Trollers, Casters, Shore Fishermen. Catches All Kinds of Fresh Water Game and Pan Fish Plus Salt Water Fish!

## WORKS WHERE OTHER LURES FAIL!

What It Will Do for You:

- CATCHES MORE FISH
- CATCHES ALMOST ALL KINDS OF FISH
- SAVES YOU MONEY ON OTHER PLUGS, BAIT AND LURES
- SAVES YOU WORK OF DIGGING WORMS, CATCHING MINNOWS, ETC.
- CATCHES THE FISH THAT WON'T BITE ON WORMS, BUGS, PLUGS, SPOONS, CANNED BAIT, FLIES, CUT BAIT OR SPINNERS!

FROM PARIS, FRANCE, COMES NEWS OF AN AMAZING fish-catching lure. The world's first truly 'live action' lure that's guaranteed to catch more fish . . . catch bigger fish . . . and catch fish when everything else fails . . . or it costs you nothing.

A Beautifully made lure that saves you hours of work digging worms, catching minnows or other live bait! . . . saves you the endless expense of continually buying expensive plugs, spinners, flies and other fancy equipment designed to catch YOU instead of fish . . . lets you make your fishing trips

more fun, more exciting and lets you enjoy every minute you're fishing from dawn till dusk . . . with more and bigger catches.

### A French Invention

The secret is a scientific 'live-action' tail that had never been patented before. Developed by a French sportsman who named it VIVIF, this wonder-working 'live-action' lure is the result of years of testing all kinds of lures on all kinds of fish . . . and watching the fish react to each lure under water. From these studies came VIVIF, the lure that works when everything else fails. VIVIF is now being used by over 350,000 fishermen in 25 countries who rave over VIVIF.

From all over come reports of record making catches . . . of fish biting where all other lures failed . . . of the sureness, the simplicity . . . the effectiveness of this miracle lure. Think what this means to you. Now at last you can catch every kind of fresh water game fish as well as salt water fish . . . and never spend a penny for fancy plugs, spinners or flies again. You can do away with digging for worms, catching bugs, frogs or minnows. You can cast, troll, shore fish . . . all with equal success. You can go out after . . . and come back with . . . bass, pike, pickerel, perch, bream, trout, walleyes, salmon, red tuna, striped bass, bluefish, weakfish, and do it time after time without any previous experience.



### PHOTO PROOF!

Fish just can't resist the amazing VIVIF with its patented "Live-Action" tail! VIVIF caught this 40 lb. salmon for Mr. G. F. Coleman and 1st prize in a fishing contest.

### Marvel of Design

Not just another stiff plastic or wood lure that 'looks good' but doesn't work. VIVIF is made of life-like latex and is the world's most life-like lure in the water . . . works better than live bait! Color combinations have been scientifically selected by fish in actual tests. Acts and wiggles like a live minnow.

### VIVIF IS IMPORTED SUPPLIES ARE STILL LIMITED

To get your VIVIF now, mail Free Trial Coupon at right. U.S. supplies are still very limited and are not yet sold in stores. Order now to be sure you'll have your VIVIF in time for your next fishing trip. Only if you act at once can we guarantee to fill your order immediately. Shipment of famous VIVIF is on its way from France. Don't delay. Mail Free Trial Coupon Today.

Each VIVIF is sent to you in a FREE clear-plastic container with Full Money Back Guarantee.

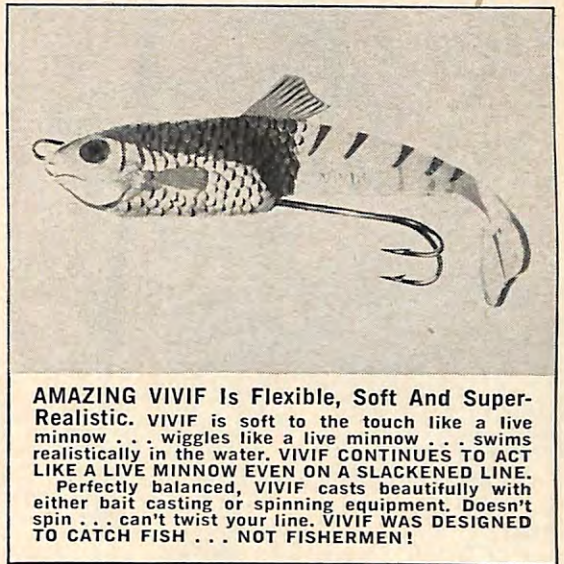

AMAZING VIVIF Is Flexible, Soft And Super-Realistic. VIVIF is soft to the touch like a live minnow . . . wiggles like a live minnow . . . swims realistically in the water. VIVIF CONTINUES TO ACT LIKE A LIVE MINNOW EVEN ON A SLACKENED LINE. Perfectly balanced, VIVIF casts beautifully with either bait casting or spinning equipment. Doesn't spin . . . can't twist your line. VIVIF WAS DESIGNED TO CATCH FISH . . . NOT FISHERMEN!

## FREE TRIAL OFFER MONEY BACK GUARANTEE!

No longer do you have to come home empty handed from your fishing trips. Avoid the costly mistake of using those "flashy" plastic and wood lures that 'look good' to you but fail to catch fish. Try amazing VIVIF . . . the French lure designed to attract and catch fish . . . without risking a penny. All you do is mail the no-risk free trial coupon below. When you receive your VIVIF, use it anywhere you like . . . use it as often as you wish to

prove its fantastic fish-catching powers.

See for yourself how VIVIF looks and acts in the water. See how easily it casts . . . how it moves through the water as realistically as any live minnow . . . even on a slackened line!

Put VIVIF to every test. If you don't agree it is the finest lure you've ever used . . . if it doesn't catch more fish and bigger fish, you have used it entirely free. It won't cost you a penny.

Over 350,000 Amazing VIVIF'S Now Catching Fish Throughout The World. Be The First In Your Area To Own One.

### MAIL FREE TRIAL COUPON TODAY

Harrison Tackle Company, Dept. 5-EK  
8-16 Kingsland Avenue, Harrison, New Jersey

Please send VIVIF Lures checked below for FREE TRIAL. If VIVIF does not catch more fish, bigger fish and make fishing more fun . . . you will refund my money including postage.

Quan.	Size	Weight	Color Comb.	Model	Price	SAVE
.....	2 1/4"	1/6 oz.	Green-Silver-Red	V-1	@ \$1.35	ALL 4 THIS SIZE FOR \$4.95
.....	2 1/4"	1/6 oz.	Black & Gold	V-2	@ \$1.35	
.....	2 1/4"	1/6 oz.	Green-Gold-Red	V-3	@ \$1.35	
.....	2 1/4"	1/6 oz.	Red & White	V-4	@ \$1.35	
.....	3"	1/3 oz.	Brown Silver-Red	V-51	@ \$1.65	ALL 4 THIS SIZE FOR \$5.95
.....	3"	1/3 oz.	Black-Silver-Red	V-52	@ \$1.65	
.....	3"	1/3 oz.	Green-Gold-Red	V-53	@ \$1.65	
.....	3"	1/3 oz.	Red & White	V-54	@ \$1.65	
.....	5 1/2"	2 1/2 oz.	Green & Yellow	V-101	@ \$2.49	ALL 3 THIS SIZE FOR \$6.95
.....	5 1/2"	2 1/2 oz.	Red & White	V-102	@ \$2.49	
.....	5 1/2"	2 1/2 oz.	Blue & Silver	V-105	@ \$2.49	

- PAYMENT ENCLOSED. Send VIVIF'S Postpaid! I save all C.O.D. Charges. (Money Back Guarantee on all VIVIF'S)
- SEND C.O.D. I will pay postman price of VIVIF'S plus C.O.D. postage. (Money Back Guarantee on all VIVIF'S)

NAME .....

ADDRESS .....

CITY ..... ZONE..... STATE.....

SPECIAL OFFER  ONE OF EACH DIFFERENT SIZE VIVIF LURE ALL 3 FOR ONLY \$4.95

CANADIAN CUSTOMERS: Order from Harrison Tackle Company 146 Wellington Street, W., Toronto, Ontario.

**GET MORE FUN OUT OF FISHING**

Here is a photo of a Frenchman who used VIVIF. The pike is 18 1/2 pounds. In England VIVIF holds a world's record. In 25 foreign lands VIVIF is catching fish for delighted fishermen. Already reports from fishermen in this country are coming in . . . reports saying VIVIF is the greatest lure they ever used. 350,000 fishermen can't be wrong. Test the magic powers of VIVIF yourself without risking a penny. VIVIF takes the luck out of fishing, lets you have more fun out of fishing . . . because you catch more fish.

# Change of Pace

By DONALD  
HONIG

ON THIS ONE SUNDAY Lenny Baron hit one that went 420 feet, clear over the fence in left center where they say nobody ever hit one before. I'll have to admit that it was a pretty good shot, but in all honesty I got to say too that there was a wind blowing out in that direction. But when everybody was talking about it that night in the drugstore I didn't say anything about the wind because I figured there's no harm in letting them have a good time talking about it.

Then the next Sunday Lenny pulled one on the line over the left field fence. He hit that one pretty good. Soon as he hit it I licked my finger and held it up in the air to see if there was much wind. To tell the honest truth there wasn't much wind at all. Anyway, the ball shot over the left field fence as quick as anything. We wouldn't have known how far it went—it took off over the 350 sign out there and it looked to me like it was beginning to die then but all the other fellows on the bench said no, that she was just beginning to rise going over the fence. I said to them: "It couldn't have gone more than three seventy-five." It was just a liner that's all. Anyway, about a half hour later George, the attendant in Reilly's gas station, came walking in through the gate with a ball in his hand. "This bounced in," he said. Right away Lenny's father jumped up and grabbed George and said: "Show me where it hit, George. Show me the exact spot." You never saw anybody so excited. He took George by the arm and shook him and took the ball and put it in his own pocket. As luck would have it (that Lenny had all the best kinds of luck) Woody was there. Woody was the one who had written the story in the previous week's paper about the 420 clout, mainly I think because he wanted to get on the good side of Mr. Baron, who owns just about everything in town except the clock on top of the post-office.

So Lenny's father and George and Woody the phony and a couple of other men took off, right in the middle of the game. Lenny's father had a tape measure or something in his car and they began by measuring behind the 350 sign and then went across the street with the thing and through the empty lot and under a couple of cars and over a fence and into Reilly's. "That's the spot," George said, pointing to

(Continued on page 49)

ILLUSTRATED BY  
DICK STONE





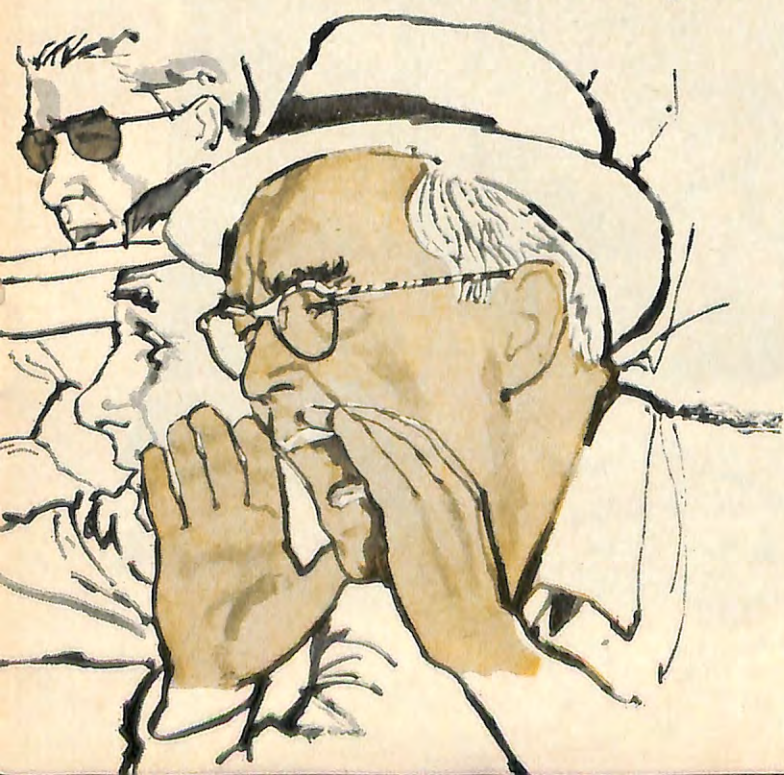

# The **Bad** Shad By TED TRUEBLOOD

Abounding in California's Russian River, these fish seem to favor just one fly—but when that fly gets a strike, be ready for battle

IF EVER a state is blessed by nature with an abundance of the things that gladden the heart of a sportsman, that state is California. The California valley quail alone should be enough to elicit daily thanks from the man who goes afield with dog and gun in autumn. The great lowlands were once the wintering grounds of untold millions of ducks and geese, and still draw a big share of all the waterfowl in the Pacific Flyway.

In the Sierra, California has the golden trout, the most beautiful of all our fresh-water fish. She has deer and bear, including grizzly, and two other kinds of quail and two species of grouse. The rainbow trout, now held in such high regard virtually everywhere in the world, came originally from California.

She has two of the greatest steelhead and salmon rivers of the entire Pacific Coast, the Eel and Klamath, and a host of other streams that, while they may

once have been as good, somehow never won the reputation of these two.

As though all this were not enough—and I have but touched the surface—California's outdoor attractions have been further heightened by the introduction of various exotic species. Among game birds, there are the Chukar partridge and pheasant, and among fish the black bass, stripers, and shad.

"At various times between 1871 and 1880, 619,000 shad fry were planted in the Sacramento River, and in 1885 and 1886, 910,000 were placed in the Columbia. There young shad found the environment congenial, suitable spawning grounds were found, and they have thrived so well that they have spread to San Diego on the south and Fort Wrangel on the north—a distance of more than 2,000 miles. The shad is now one of the most abundant and most delicious foodfishes in the markets of

San Francisco and other West Coast cities." (American Food & Game Fishes, by David Starr Jordan and Barton W. Evermann, copyrighted in 1902.)

Some 50 years later, I met the shad. The meeting was a memorable one, partly, at least, because I was introduced by a mutual friend of the same name. Bill Schaadt (pronounced shad) is the wildest fisherman I know. He lives in Monte Rio, California, on the Russian River, and he is a bachelor. He works barely enough to buy the necessities of life, including tackle, and he fishes the rest of the time.

I went down one year in May to fish with him and another friend, Myron C. Gregory, and before I got home I had fished with many of the fine anglers of the Bay Area, including Howard George, Boots Rogers, Doug and Angie Merrick, Jimmy Green, Carl Ludemann, (Continued on page 44)



This painting by Don Moss shows the red and silver Ludemann Shad Fly, magnified to twice the actual size of the No. 4 hook.

# Home Again!



Yes, for our Brother Elks whose families and other ties have been severed, admission to the Elks National Home is indeed like coming "home again"; for it has consistently been conducted as a REAL HOME in which each resident Brother has the fullest possible freedom of action, with every consideration for his right of personal privacy, and wherein every effort is made to insure his comfort, health and happiness.

Located in the foothills of the famous Blue Ridge Mountains at Bedford, Virginia, the modern buildings and spacious grounds of the Elks National Home now provide a haven for about 275 resident Brothers from every part of our country. Everything for their comfort and welfare is provided—private rooms with hot and cold running water, good food, excellent medical care, a power laundry, a subordinate lodge, golf, television, recreational facilities and companionship.

Any aged or indigent Elk, in good standing for the preceding five years, who is incapable of earning his living, may apply for admission. Approval of the applicant's home lodge is necessary, as well as reasonable health and other requirements. The cost of maintaining a member at the Home is unbelievably low and many times pension or old age benefits will meet the entire cost of maintenance. The Home has a capacity of about 400 residents. Because of its distinctive fa-

cilities, excellent administration and low cost, it should be filled all the time.

The Order is fortunate to have the devoted services of Superintendent Thomas J. Brady to operate the Home under the supervision of the Board of Grand Trustees. Brother Brady is an experienced Elk. He is an excellent administrator and has a great desire for economy and efficiency. Under his administration many new improvements have been made to modernize the physical plant and methods of operation at the Home. All of them have proved beneficial. Just visit the Home and talk with the Brothers living there to get an unsolicited testimonial of their admiration for this compassionate Elk, Superintendent Tom Brady!

It is unfortunate that so many of our members do not know about the Elks National Home. If you have not visited the Home recently or have never visited it, you should take the first opportunity to do so. You will be amazed! But the next best thing to a visit there, is to see the new color motion picture of the Home. It is entitled "Home Again" and may be arranged for by writing the Grand Secretary. It makes a splendid after-lodge entertainment and will make every member more proud that he is an Elk—that he has a part in bringing the opportunity to his brothers to go HOME AGAIN!

*Horace R. Wisely*  
HORACE R. WISELY, *Grand Exalted Ruler*



# Fastest Growing Sport

This year more than 37,000,000 enthusiasts will enjoy the recreation and relaxation of boating

By **PHIL REAVIS**

Associate Editor, Popular Boating

FOR WHAT IT WAS WORTH TO THEM—fun on the water, fishing, finding peace and relaxation away from business, or just getting wet, some 37,000,000 Americans went pleasure boating last year. And predictions are that even more will participate in the nation's fastest growing sport this year.

Well, it wasn't long ago, little Lake Thingamabub was just a pond where a man could row out and drop his hook almost anywhere and sit back and go to sleep dreaming about giant sunfish. Nowadays, for company he has 100-horsepower outboard rigs fit to cruise a family reunion, and little "punkin-seeds" zooming about like dragon-flies, and fleets of sailboats decorating the water with their bright wings.

"More than 7,000,000 pleasure boats currently in use in the United States!" Those are the statistics. "Builders report they can hardly keep up with new boat orders."

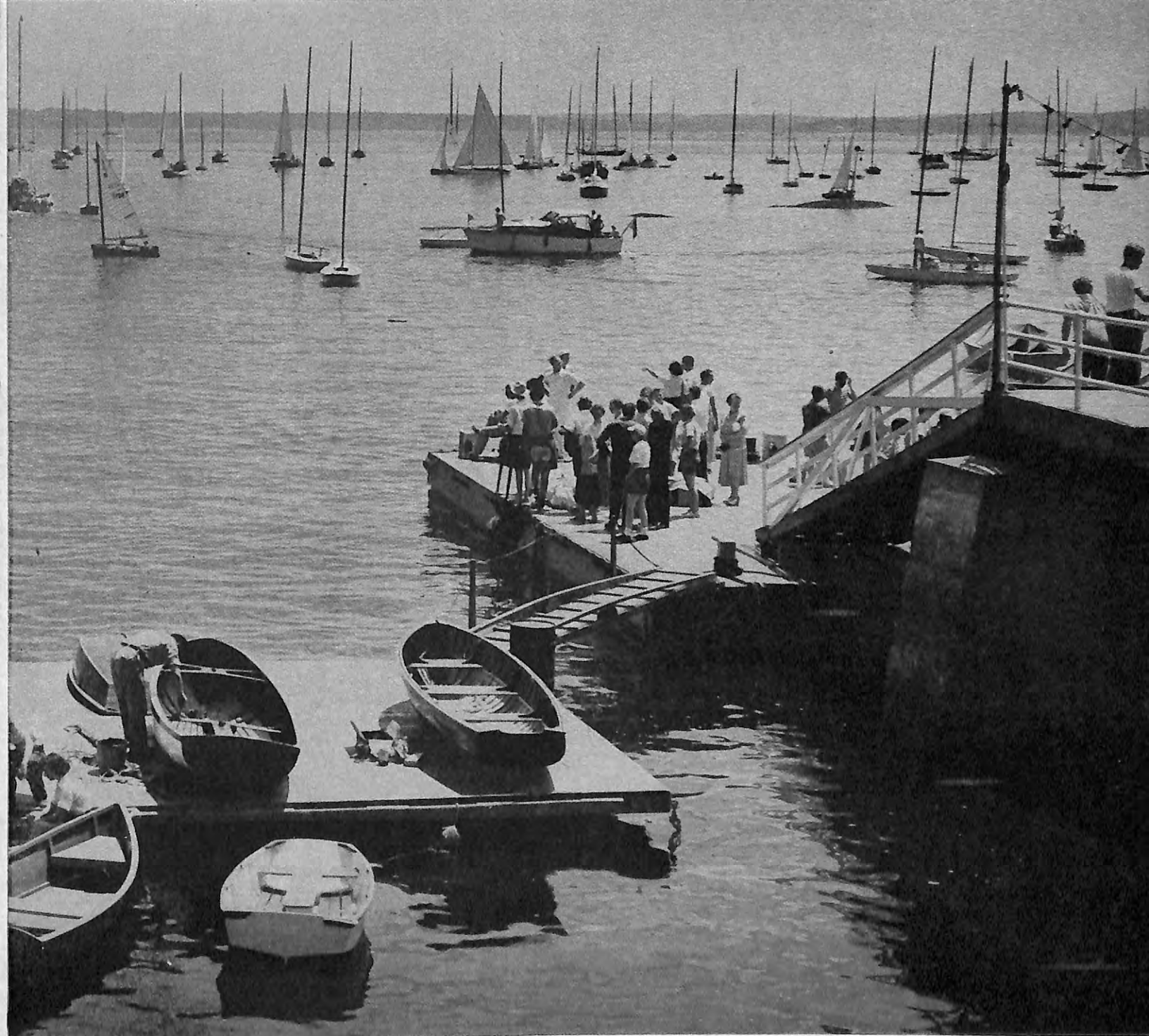

PHOTOGRAPHED AT THE LARCHMONT, N. Y., YACHT CLUB BY MORRIS ROSENFELD

It makes a person wonder. Where did this boating craze come from? Where is it going? What is it, now, a fad, a sport, a way of life? And if a man were inclined to swap his tar-bottomed, slab-sided skiff for one of those planing hulls, or a family cruiser, how would he go about it without biting off more than he could chew and swamping himself and his pocketbook?

First, he might as well assure himself that boating is no fad—it's here to stay. The hundreds of thousands of people who repeatedly "go down to the sea in ships" in such unlikely places as Oklahoma, Arizona and Nevada will never shed a tear over the lost 200 square miles of land under the waters of Lake Texoma, officially known as Denison Reservoir, on the Red River in Texas and Oklahoma; and Lake Mead, 230 square miles of cool water covering once arid desert behind Hoover Dam on the Colorado River. In the Lake Mead National Rec-

reation Area, in Arizona and Nevada, last Labor Day weekend alone, 3,550 boats were counted on Mead and Mohave and over 7,500 persons water-skied on the two artificial lakes—according to an official statement by Charles A. Richey, Park Superintendent. On Lake Texoma, 7,000 pleasure boats are registered for use.

Those folks will never give up the sport of boating. Neither will millions of Americans elsewhere—whether they live near the sea or travel to one of the many lakes and rivers of the country.

On high mountain lakes; on great artificial reservoirs like the 2,300-mile shoreline Kentucky Lake; on wide old rivers—the Ohio, the Missouri, the Mississippi; on narrower streams coursing the varied landscape; on the fresh-water seas of the Great Lakes and the bays and sounds and open water of America's 12,000-mile long seaboard—everywhere—there are (*Continued on page 46*)

**When**



# Big Business Moves to Town

Industrial plants are good neighbors—bringing civic improvements for your city, new jobs and business markets for you, better schools for your children

by **DICKSON HARTWELL**

ILLUSTRATION BY BIRNEY LETTICK

FROM THE SOUTHERN STATE for which it is named, Georgia Power Company has been telling the rest of the country of the attractions of Georgia as a place to do business. As a result of this and allied efforts, backed by many tangible inducements, more than 1,100 new industries have come to settle there. They've brought bags full of money for new construction—\$485 million in capital investment. They've created 77,000 new jobs, spreading as many pay envelopes across the state—\$240 million a year. They've helped Georgia people to prosper. Georgia Power is a good neighbor.

At Horseheads in northern New York, the local Westinghouse plant helps with fire protection, provides laboratory facilities for the police, and even changed the village accounting system from single to double entry bookkeeping. Mayor Marcus Dilmore says Westinghouse is a good neighbor.

In East Chicago, Indiana, Inland Steel Company sparked a community rehabilitation program which has provided better housing, new parks, an overpass for 13 railroad tracks and an

improved water supply. In twenty-two states, American Oil Company fosters a tractor-awards program for 4-H Clubs, instructing farm youth in the maintenance of vital equipment. In New York, Brooklyn Union Gas Company gives free appliance adjustment service to 1,000,000 customers while cutting rates six times in eight years.

These, too, are good neighbors. They are part of a widespread and increasing change in the attitude of big business—and much of little business, also—toward cities and towns where plants are located. It's a new and cheering good neighborliness. Some of it may be pure selfishness. Much of it results from enlightened self-interest. But the most of it—and the best of it—is as one executive put it, "What is good for the community is good for us."

The range of its expression is enormous. A southern company air-drops Christmas toys and candies to residents of nearby cross-roads hamlets. In Florida, a shore-front factory chimney is decorated to resemble a lighthouse. A midwest corporation bulldozes a *(Continued on page 40)*

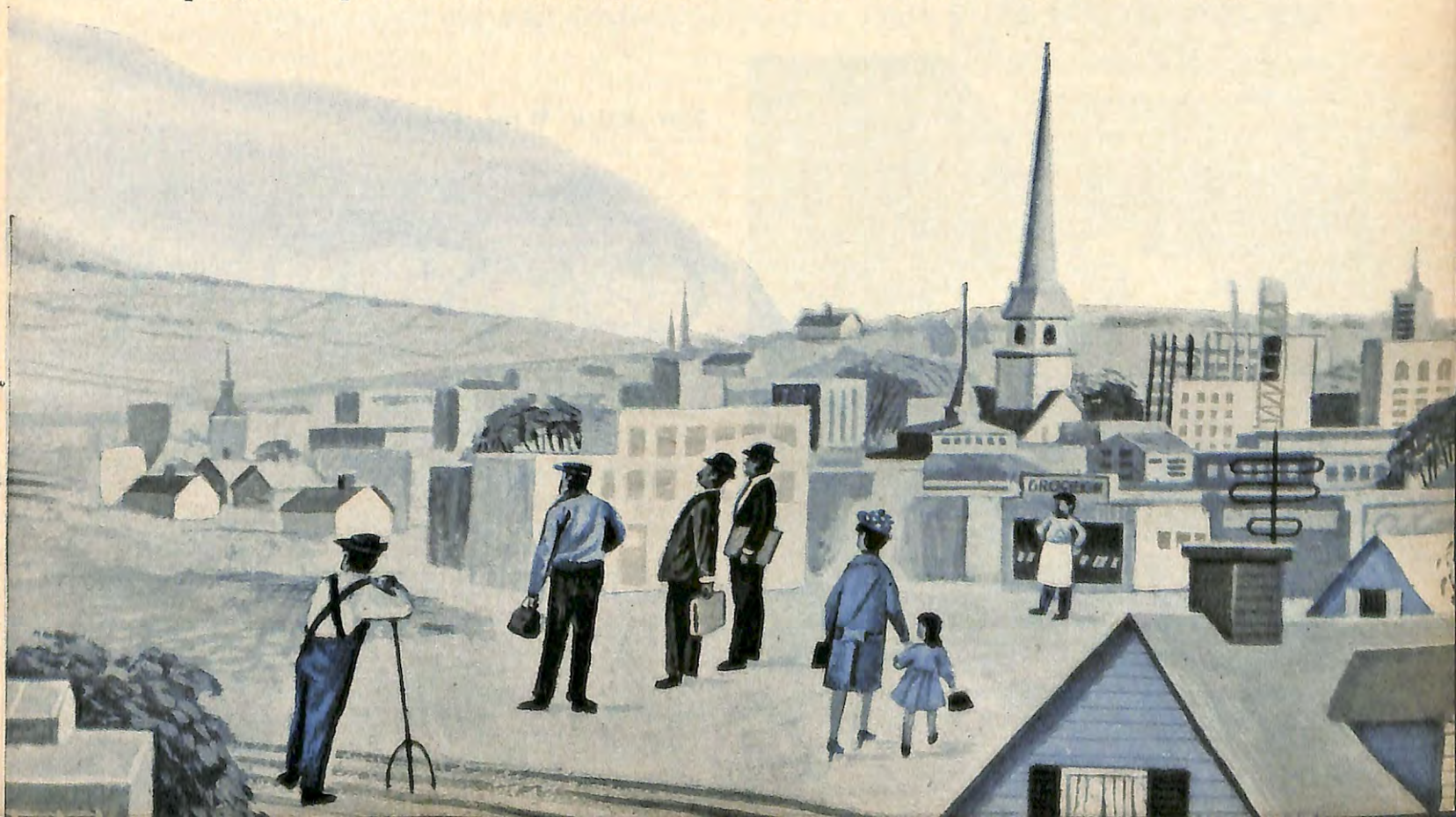



Along the steep, narrow streets of Old Quebec are buildings erected by early French settlers.

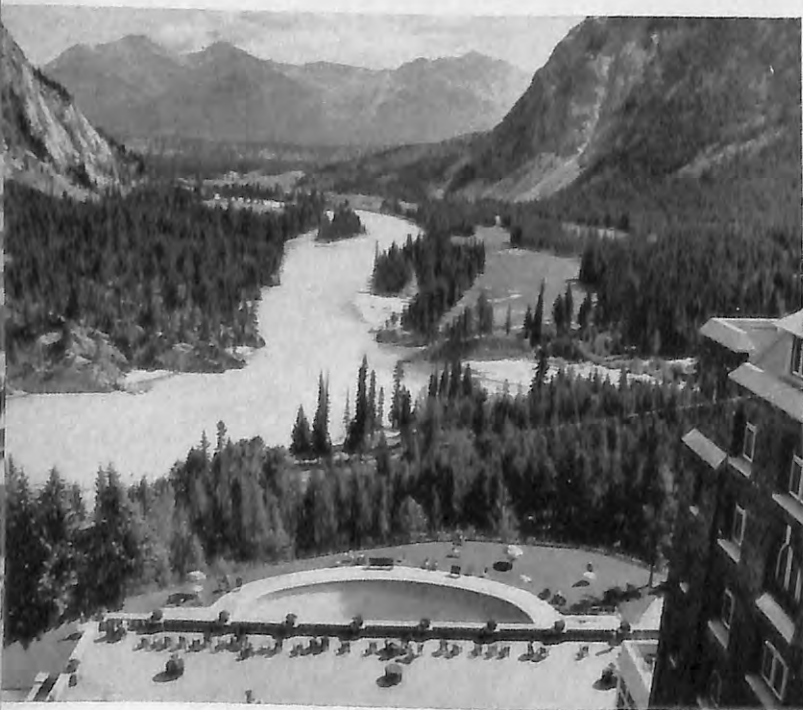

Viewed from the roof of Banff Springs Hotel in Alberta, the Bow River winds away into the rugged Canadian Rockies.

**For Elks Who Travel**

# CANADA

Places to go and things to do  
in the four great tourist areas  
north of our border

By **HORACE SUTTON**

PHOTOS BY PHILIP GENDREAU



**T**HE SNOW should be melted down to ankle depth up in Canada by the time this reaches your mailbox; and by the time you're ready to point the radiator cap northward, things in the real estate up above us ought to be peaceable and pleasant.

For those members of the class who would like a little brush up, Canada splits itself into an Atlantic region, a Central region, a Prairie region and the Mountains. This seems to me to be a little bit too much geography-class, and I would like to define it, or perhaps group it, a little more touristically. In the first place there are the Maritimes, the provinces of Nova Scotia, New Brunswick, and the tiny tract of Prince Edward Island. New Brunswick grows out of the top of Maine which in many ways it resembles. The Province has been very much in the news this year with the success of Dore Schary's Broadway play "Sunrise at Campobello"—which is partly set in the Roosevelt summer home at Campobello Island. But tourists here gather in the great roomy hotel of St. Andrew's by the Sea and watch lobsters and take trips out to Grand Manan Island and play golf and sniff the fine Bay of Fundy air. Between St. John and Moncton is the Fundy National Park which offers bungalow accommodations in the rugged forest terrain. There are campgrounds, too, for those who think they're younger than they are.

Prince Edward Island is a quiet green little nest with rolling fields of clover, small, relatively inexpensive hotels, broad beaches surrounded with warm water, and some handsome golf courses. Nova Scotia is steeped with history, surrounded by the sea and by game fish. At Grand Pre it has bittersweet memories of the Acadians—everybody here remembers Longfellow's "Evangeline"—and at Port Royal it has recollections of the early 17th Century settlers—Champlain and Poutrincourt. Halifax holds three museums loaded to the rafters with relics of Canada's stormy history of battles between the French and the British for the New World. Eight-day tours of Nova Scotia, crossing from Bar Harbor, Maine, to Yarmouth, Nova Scotia, and looking in at Grand Pre, Halifax, Digby Pines and the fishing port of Lunenburg, costs \$219, including a three-hour flight back to New York over the New England and New Brunswick coastline. Be sure to make ferry reservations in advance unless you are on such a package tour.

Other packaged tours that take in virtually all of lower Nova Scotia, then cross over to Cape Breton Island, begin at \$249 per person. They leave New York on Sunday and return on Sunday. Bus tours out of New York covering all three Maritime Provinces by way of Bar Harbor require two weeks and cost \$205, including two full days at Digby Pines, a famous resort hotel in Nova

Scotia, owned by Canadian Pacific. For anybody just putting in at Digby independently of a tour, rooms run from \$15 to \$17 a day per person, and cottages, of which there are thirty-one, begin at \$38. Golf, tennis and swimming in the open-air, heated, glass enclosed pool are all available, and the place is hay-fever free.

New door to the Maritimes is the immense province of Quebec, still holding to its French ways, which makes it, of course, that much more interesting for the traveler. Montreal, so near the United States, prints its signs in French and in English, and in summer there are notices on the buses that say, "Baseball Ce Soir." Part of Quebec, a long thin slice which borders the top of New England and New Brunswick, lies on the near side of the St. Lawrence. For the traveler this sliver includes the Gaspé which is a seacoast reminiscent of Brittany on the Coast of France. The St. Lawrence itself, and its tributary, the Saguenay, are pleasant boat trips in summer, and there are the two major cities, Montreal, which is big and sophisticated, and Quebec, smaller and picturesque, with great memories of Wolfe and Montcalm, that are lodestones themselves.

In that mass of land to the north, full of lakes and forests, there are literally thousands of resorts. Let's look at a few to get an idea. For instance, in the Gatineau there is Le Chaperon Rouge at Blue Sea Lake. It is tiny, it has a sandy beach, dancing on week-ends to a five-piece band, fishing in Blue Sea Lake. Nothing pretentious, but then neither is the price—\$12 daily for one person or \$75 a week. Or take Kan-a-Mouche Fishing and Hunting Lodge at St. Michel des Saints, in Berthier County, 98 miles north of Montreal. Cessnas will fly you from Montreal's airport at \$72 per trip (three passengers to a plane), or there is limousine service from Montreal. Once there, you'll find seven bungalows set along the lake, and rates running from \$16.50 to \$20 a day per person. Trout, pike, walleyes and bass are the catch; moose, deer, bear, partridge and duck in the fall. Meals are dedicated to fishing types, with a French chef in residence.

As for package tours, a week in Montreal, Quebec and the Laurentians costs \$119.50 from New York, four days around the Gaspé comes to \$100 and up; Quebec, Murray Bay, and the Gaspé Peninsula in eight days costs \$249 from Montreal; and Montreal, Quebec and the Saguenay cruise comes to \$206 from Boston for nine days. Everybody got that?

Now that brings us to the huge province of Ontario, a vast area that stretches across the top of the Great Lakes with room left over. Or to put it another way, Ontario is as big as Texas with two Oklahomas to boot. Puddles of

(Continued on page 38)



## THERE ARE PLENTY MORE WAITING FOR YOU!

Whichever you favor . . . bass, pickerel, trout, maskinongé, ouananiche, salmon, you will find them in the beautiful unspoiled lakes and rivers of Québec.

To help plan a fishing trip that will be really memorable, write for maps and booklets, to: Provincial Publicity Bureau, Parliament Buildings, Québec City, Canada; or 48 Rockefeller Plaza, New York 20, N.Y.



# LA PROVINCE DE Québec



## VISITING MAINE?

A cordial welcome awaits you at the new Biddeford-Saco Lodge No. 1597, located on Route 1, two miles east of Saco. Fine restaurants and accommodations are located nearby, and you're within short driving distance of famed Old Orchard Beach. When in Vacationland, stop and see your down-east friends at Biddeford-Saco.

## You'll Enjoy Your Stay in WILLIAMSPORT, PA.

Williamsport, Pa., Lodge No. 173 welcomes traveling Elks. Our hotel facilities are stag only with clean, livable rooms—20 of them with connecting showers for transient guests. Rates—\$2.50 and \$3.00. Well equipped grill with an excellent cuisine. Dining room for public use.

Yes, you'll enjoy your stay in Williamsport if you stay at the Elks.

# HEADING EAST

AT THE LODGES he visited in February (Stray Elks Round-Up Month) Grand Exalted Ruler Horace R. Wisely appropriately stressed the role of subordinate lodges in making welcome any Elks who are new in a community. At Grand Junction, Colo., Lodge on Feb. 4, Mr. Wisely praised local Elks for its efforts in this direction, and urged still greater efforts. Speaking before some 350 Elks—including a number of visitors from neighboring lodges—the Grand Exalted Ruler also lauded the Elks of the state for their various civic activities, including the support of Laradon Hall, the institution in Denver for handicapped children. On hand for the Grand Junction meeting were Grand Lodge Membership Committeeman Campbell F. Rice, State Pres. Dr. Leo Schneider, District Deputies Clarence Metcalf and Merrill Ormsbee and Exalted Ruler Glen I. Dollar.

**NEW HAVEN.** On Feb. 11, Mr. Wisely arrived in New Haven, Conn., Lodge for the celebration of its Diamond Anniversary. Some 300 guests were at the dinner held in the new lodge rooms, which have been in use for less than a year. Attending this 75th Birthday Celebration were Grand Esteemed Loyal Knight Arthur J. Roy, State Pres. Dr. G. A. Caillouette and District Deputy Richard C. Hannan. Lodge Secretary Edwin J. Maley served as Dinner Committee Chairman and Toastmaster.

**NEW YORK STATE.** The Grand Exalted Ruler was able to visit three neighboring lodges on Feb. 18, beginning with a luncheon meeting at Mamaroneck, N. Y. Following this meeting, Mr. Wisely proceeded to New Rochelle, where the lodge held a cocktail hour meeting in his honor, and he then visited Ossining Lodge, which entertained him at dinner. On this round of New York State visits, Mr. Wisely was accompanied by James A. Gunn, Chairman of the Grand Lodge Membership and New Lodge Committee. Also present at New Rochelle were District Deputy Martin Traugott, who is Chairman of the State Scholarship Committee, Exalted Ruler Julian Hyman, Lodge Trustee John Comming and Chaplain John Doherty. During this visit, Mr. Wisely had the opportunity to congratulate Mr. Traugott's 13-year-old son Roy on becoming an Eagle Scout in the Troop spon-

sored by the lodge. Among the 300 in attendance at Ossining were State Vice Pres. C. B. DeLuca, Past District Deputy Leo H. Heithaus, a number of Past Exalted Rulers, Exalted Ruler D. P. Doorley, Lodge Secretary P. E. Tierney and Ossining's Mayor Jesse A. Collyer, a lodge member.

The next day, Feb. 19, found Mr. Wisely at Freeport, N. Y., Lodge, where he was greeted by a delegation of Boy Scouts, the Freeport High School band and over 300 Elks. The lodge held a dinner in honor of the Grand Exalted Ruler, and afterward a meeting was held in the lodge hall. Dignitaries present included Past State Pres. Franklin J. Fitzpatrick, District Deputy Morris Milstein and Past District Deputy Gordon H. Meyer. In charge of the proceedings was Exalted Ruler Joseph T. Kiepler.

**JOPLIN, MO.** The Grand Exalted Ruler attended the Fifth Annual Four-State Initiation at Joplin, Mo., Lodge on Feb. 21, when Elksdom welcomed candidates from Arkansas, Kansas, Missouri and Oklahoma. More than 500 Elks and their ladies were present (for a full report see News of Lodges in this issue).

**TOLEDO, OHIO.** The 39th Annual Elks National Bowling Tournament opened in Toledo, Ohio, on March 7, a date which coincided with the dedication of Toledo Lodge's new \$300,000 building. This enabled the Grand Exalted Ruler to deliver the principal address at the dedication, and also to open the tournament by rolling the first ball. Dignitaries present for the double event included Past Grand Exalted Rulers Edward J. McCormick and Fred L. Bohn, Grand Forum Chief Justice John C. Cochrane, Grand Inner Guard James W. Plummer, District Deputy E. J. McCormick, Jr., Past District Deputies R. F. Coningham, H. S. Green and K. P. Rumpf, and Mayor John W. Yager.

A highlight of the dedication ceremony was the unveiling of a portrait of Past Grand Exalted Ruler McCormick, honoring his devoted service to the Order. At this time it was announced that the lodge is pledging \$1,000 for the Elks National Foundation in the name of Dr. McCormick, who is Treasurer of the Foundation. Exalted Ruler Edward J. Eppstein presented a special gavel to Chief Justice Cochrane,



At the dedication of a new lodge building in Toledo, Ohio, on March 7 a portrait of a new lodge building in Toledo, Ohio, on March 7 a portrait was unveiled in tribute to Past Grand Exalted Ruler Edward J. McCormick. Dr. McCormick is standing at right, directly beneath the portrait. Pictured with him at the unveiling are (from left) Exalted Ruler Edward J. Eppstein, Past Grand Exalted Ruler Fred L. Bohn, District Deputy Edward J. McCormick, Jr., and the Grand Exalted Ruler. Mr. Wisely also opened the Elks National Bowling Tournament in Toledo that day.



Seated at the speakers' table as they enjoy a dinner at Atlanta, Ga., Lodge on March 11 are (from left) the Reverend Father James King, Past Grand Chaplain of the Order, Mrs. O. L. Purdue and Exalted Ruler Purdue, Past Grand Exalted Ruler John S. McClelland, Grand Exalted Ruler Horace R. Wisely and Mrs. Wisely, Atlanta's Mayor Pro-tem Lee Evans—who is a Past Exalted Ruler of Atlanta Lodge—Grand Treasurer Robert G. Pruitt and Mrs. Pruitt, and Special District Deputy Roderick M. McDuffie.



At Ossining, N.Y., Lodge on Feb. 18 are (from left to right, seated) Past District Deputy Leo H. Heithaus, Mayor Jesse A. Collyer, Mr. Wisely, Exalted Ruler D. P. Doorley and Past Exalted Ruler P. E. Tierney. Shown standing, from left to right, are Brother J. P. Pellegrino, Past Exalted Rulers F. J. Mascola and H. H. Barrett, Brother Dominic Revellese, Grand Lodge Membership and New Lodge Committee Chairman James A. Gunn, Past Exalted Rulers I. C. Hotaling, F. T. Weiss, B. J. D'Amato, J. J. Doorley, T. P. McGowan, C. H. Slattery, S. J. Tritto, R. L. Dymes and J. H. McSorley, Brothers T. J. Stanton, C. S. Brundage (who is a Charter Member), C. L. Marshall, State Vice Pres. C. B. DeLuca and Past Exalted Ruler V. R. Zingaro.



Shown attending a cocktail party on the afternoon of Feb. 18 at New Rochelle, N.Y., Lodge are (seated, from left to right) Esteemed Leading Knight John Gardner, Exalted Ruler Julian Hyman, Grand Exalted Ruler Wisely and Esteemed Loyal Knight Philip Beninato. Standing are State Scholarship Committee Chairman Martin Traugott, Lodge Trustee John Comming, Chaplain John Doherty, Esteemed Lecturing Knight Thomas Guion, Chairman James A. Gunn of the Grand Lodge Membership and New Lodge Committee.



Leaving the airport for Grand Junction, Colo., on Feb. 4 are (from left) Grand Lodge Membership and New Lodge Committeeman Campbell F. Rice, Mrs. Rice, Mrs. Wisely, Mrs. Glen I. Dollar, Exalted Ruler Dollar and Mr. Wisely.



Reading ELKS MAGAZINE at Riverside, Calif., Dec. 29: PDD R. S. Waite, Mr. Wisely, Past Grand Exalted Ruler L. A. Lewis, Grand Secretary L. A. Donaldson.



This meeting took place at the airport en route to Joplin, Mo., Lodge for the Fifth Annual Four-State Initiation on Feb. 21. Pictured from left to right are Exalted Ruler Joe Ben Gold, District Deputy Walter L. Schweikert, the Grand Exalted Ruler and Mrs. Wisely, Mayor C. C. Haynes, who is an Elk, and Chamber of Commerce President Pat Patterson, who is also a member of the Order. More than 500 Elks and their ladies, from lodges situated throughout the four-state area—Arkansas, Kansas, Missouri and Oklahoma—convened in Joplin to attend the meeting this year, making it a great success.



In appreciation of Elksdom's aid to youth, the Boy Scouts of Nassau County welcomed the Grand Exalted Ruler to Freeport, N.Y., Lodge for his Feb. 19 visit. Shown with them before the lodge building entrance (from left to right) are Past Exalted Ruler R. A. Hungerford, Elk Theodore Lang—who greeted Mr. Wisely on behalf of Mayor William Glacken—the Grand Exalted Ruler and Past Exalted Ruler T. N. de Giacomo.



Dining beneath a large welcoming sign at Santa Ana, Calif., Lodge on Jan. 29 are (from left to right) Past Grand Exalted Ruler L. A. Lewis and Mrs. Lewis, Grand Exalted Ruler Horace R. Wisely and Mrs. Wisely, and District Deputy Robert B. Webb.



The Diamond Anniversary of New Haven, Conn., Lodge was celebrated on Feb. 11 and greetings were exchanged by these Elks (left to right): Exalted Ruler Alfred D. Mercier, Lodge Secretary Edwin J. Maley—who was Toastmaster for the occasion—Mr. Wisely, Grand Esteemed Loyal Knight Arthur J. Roy, State Pres. George A. Caillouette and District Deputy Richard C. Hannan.



Photographed as they prepare to leave the airport on the way to Florence, Ala., Lodge on March 9 are (from left to right) Past District Deputy Adin Batson, Past Grand Exalted Ruler John S. McClelland, Mrs. Wisely and the Grand Exalted Ruler.

who presided during the dedication. The new building contains offices, a lounge, dining room and social room, in addition to the meeting room, which seats 400.

Elks National Bowling Assn. President W. R. Huhn reports that a record 1,425 teams from 13 states are participating in the tournament this year. On hand with Mr. Huhn and Mr. Wisely for the opening day were National Bowling Secretary E. N. Quinn, Ohio Bowling Pres. Arthur Socin, Toledo Bowling Pres. Phillip Baker and Tourney Chairman James E. Corrigan.

**FLORENCE, ALA.** When Mr. Wisely visited Florence, Ala., Lodge on March 9, he gave a 15-minute televised interview over Station WOWL-TV; in order to reach as large an audience as possible, this interview was recorded and re-broadcast later on four radio stations. Accompanying Mr. Wisely on the visit to Florence, and to Atlanta and Augusta, Ga., was Past Grand Exalted Ruler John S. McClelland. The Grand Exalted Ruler's party was met at the airport by a delegation, including Past District Deputy Adin Batson, Exalted Ruler Perry English, Past Exalted Ruler W. R. Chisholm, Jr., Sheffield, Ala., Exalted Ruler R. S. Walker, Sheffield Past Exalted Ruler Gilbert Mayer, and C. L. Beard, Mayor of Sheffield and a member of the lodge. A cocktail hour and dinner were held for the Grand Exalted Ruler at Florence Lodge that evening.

**GEORGIA.** Mr. and Mrs. Wisely and Past Grand Exalted Ruler McClelland were met at Atlanta Airport on March 11 by Grand Treasurer Robert G. Pruitt, Special District Deputy Roderick M. McDuffie, Exalted Ruler O. L. Purdue and Lodge Secretary T. M. Brisendine. After a tour of Grant Park, under the guidance of Brothers George Simons, Parks Dept. General Manager, and Alderman Charles Leftwich, the party enjoyed a luncheon at the lodge. Among those present were Past Grand Chaplain Father James King, State Vice Pres. James S. Tuten, District Deputies Henry Ansaldo, J. E. Simmons and D. C. Thompson, Mayor Pro-tem Lee Evans (who is a Past Exalted Ruler) and a number of Exalted Rulers and Secretaries from neighboring lodges.

Arriving at Augusta Lodge on March 13, Mr. and Mrs. Wisely and Judge McClelland attended a luncheon that afternoon and a dinner-dance that evening. Judge C. Wesley Killebrew, a Past District Deputy, served as Master of Ceremonies, and the guests were also welcomed by Exalted Ruler Jack E. McGahee. Mr. Wisely took this opportunity to commend Georgia Elks for their work to aid needy individuals and handicapped children through such institutions as the Aidmore Crippled Children's Hospital and the Georgia School for Mentally Defective Children at Gracewood. • •



Prior to a banquet held on March 13 at Augusta, Ga., Lodge, Grand Exalted Ruler Wisely relaxes in the lodge rooms as he converses with Past Grand Exalted Ruler John S. McClelland (seated on the left) and Augusta's Exalted Ruler Jack E. McGahee.

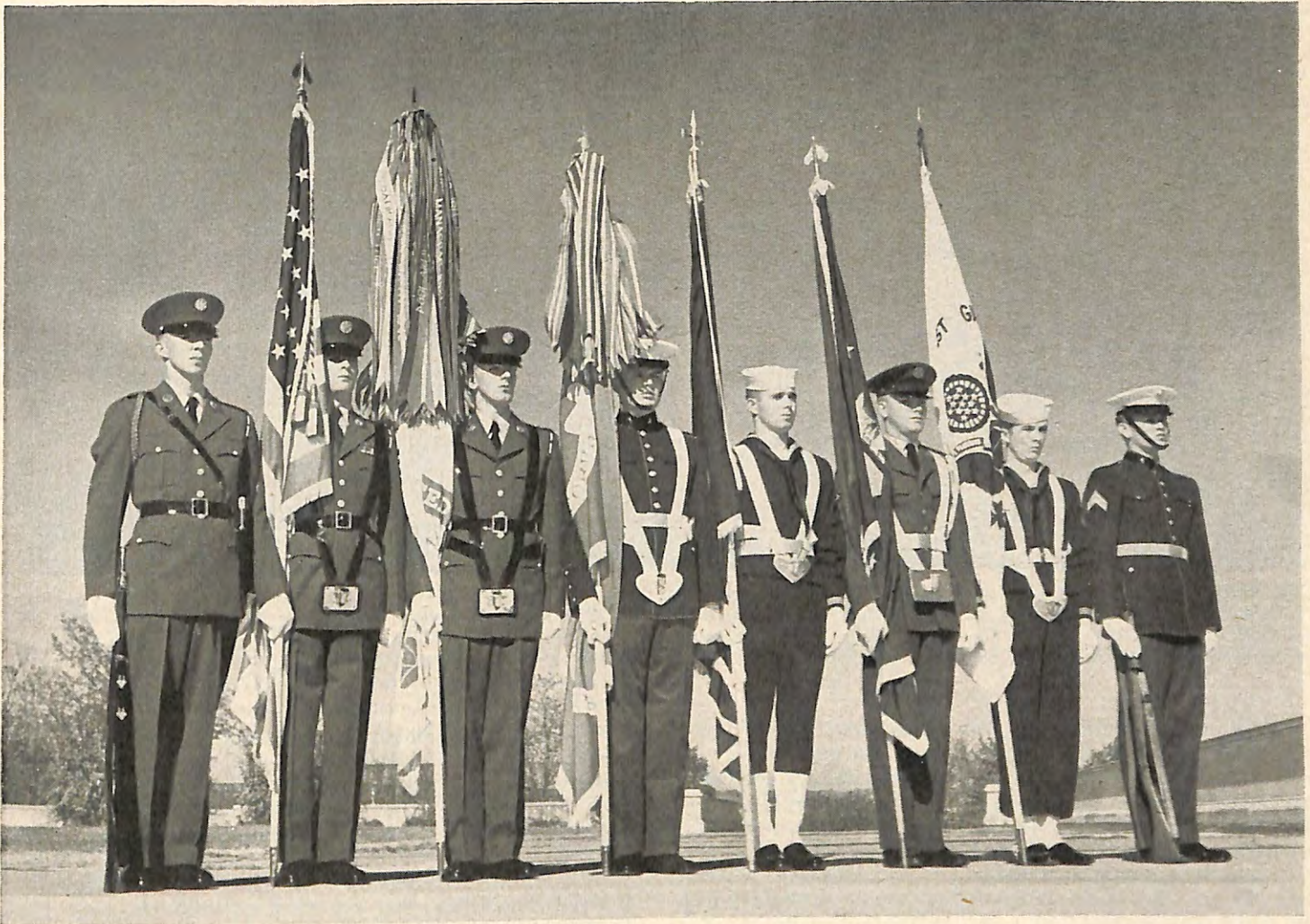

### Elks National Service Commission

# “POWER FOR PEACE”

Armed Forces Day—May 16

OVER the past decade, Armed Forces Day, the third Saturday of May, has become an important date in the calendar of the Nation.

Prior to 1950, Army Day, Air Force Day, Navy Day, and Marine Corps Anniversary were celebrated separately. In line with the unification of the services and the creation of a Department of Defense, Armed Forces Day was proclaimed to symbolize the close working relationship of the Army, Navy, Air Force, Marine Corps, Coast Guard and Reserve components.

“Power for Peace” is the current slogan of the observance and eloquently emphasizes the role of our Nation’s defenders in these uncertain days of cold war. The forces of communism have

made it abundantly clear that their aim is world domination. They have been encouraged in this ambition by the ease with which they have been able to subjugate nations which were helpless because of the lack of adequate defense. We can be certain that the prime target is the United States and the sabre-rattling of the Kremlin aggressors leaves no doubt as to their ultimate intentions.

Consequently, dedicated American men and women, here and abroad, who make up the strong bulwark of our military strength in the various branches of the service, are our “Power for Peace”. Allied with them in this effort are civilian groups such as the U.S.O., Civil Air Patrol, Selective Service, Civil De-

fense, Red Cross and the Elks, through its National Service Commission.

On Armed Forces Day, all branches of military service invite the public to see the defense team in action. Open House programs at Armed Forces installations will be the order of the day. All Elks lodges in the vicinity of such installations are urged to contact the officers in charge in order to give full support to this annual tribute to the protectors of peace.

Those who are dedicating their lives to defend our shores against possible invasion are certainly entitled to an annual expression of gratitude and encouragement. We feel sure that Elks need no urging to participate in this patriotic salute to our Armed Forces.

# Return of the "Strays"



**RED BANK, New Jersey,** Lodge combined its "Stray Elks Night" with a Valentine Dance and its monthly birthday party attended by over 250 persons. Pictured are, left to right, seated, Richard Spillane, Paramus; J. A. Zaloom, Rutherford; Bayonne P.E.R. W. F.

Stalling; Jack Banther, Newark; standing: Past State Vice-Pres. A. C. Kind; C. R. Peterson, Elmhurst, Ill.; P.D.D. C. A. Hotaling; host E.R. Joseph Quail; R. E. Culbertson, Pocatello, Ida.; Bayonne P.E.R. R. F. Calvin, and M. W. Begala, Phillipsburg.

"Make them feel at home," Grand Exalted Ruler Horace R. Wisely urged the subordinate lodges last November.

"They talked of their travels and the lodges they had visited, and before the evening was over you could see the feeling of being a stranger had completely disappeared," Hammond, Ind., Lodge reported in March.

"They" are our Stray Elks, and what transpired between Mr. Wisely's statement and the Hammond report should be an inspiration to every lodge in the Order.

The "Stray Elk" is a member who no longer resides within the jurisdiction of his home lodge, and when it was found these "Strays" make up a large part of the number of lapsed members each year, the Grand Exalted Ruler decided to do something about it. Believing that not all these men lose interest in Elkdom and so allow their membership to lapse, but that many may feel Elkdom has lost interest in them, he urged the lodges to make a concentrated effort to round-up the Strays in their areas, invite them to participate in their activities and dedicate the month of February to that purpose.

The Grand Lodge Committee on Lodge Activities played a large part in the success of this endeavor, and while Chairman Vincent H. Grocott is still receiving answers to the questionnaire he sent to the lodges concerning this program, at the time of this writing he had heard from 381 lodges. Their programs were responsible for rounding up 6,292 Strays, and the comments included with their reports are both interesting and enlightening.

It must be remembered that the prime purpose in rounding up these members is to keep Elkdom alive in their minds, to rekindle their pride of membership so that they will not be lost to the Order. The Grand Exalted Ruler therefore urged that in planning these programs the accent be placed on friendship born of the common bond of Brotherhood—how better evidenced than through a warm invitation to share in Elkdom's activities and congeniality?

The majority of lodges reporting not only called the program an excellent idea, but let Chairman Grocott know that the Stray Elks they'd entertained were also tremendously enthusiastic about it. To some lodges, it is a brand-new activity; others have had such a program in operation for several years. An impressive number suggested that it be continued as a regular undertaking—some urging that it be

a semi-annual or annual event, others urging that it be a monthly affair. Let it be stated here that the Grand Lodge is more than willing to have these Round-Ups held regularly, with the decision as to how often left to each lodge.

Coeur d'Alene, Ida., San Luis Obispo and Whittier, Calif., Amarillo, Texas, Weehawken, N. J., and Ballard (Seattle), Wash., Lodges were among those who feel that the program is most valuable and that to make it successful lies in keeping in personal touch with the Strays in their areas—particularly, to place them on the lodge's mailing list—a practice of LaGrande, Ore., Lodge, for instance, which is one of several reporting that the Stray Elk effort is one of long-standing on their agenda.

While no effort was made to influence the Strays to sever their ties with their home-town lodges, Chairman Grocott's summation reveals that of the more than 6,000 Strays entertained during February, 1,656 had decided to apply for



**BOULDER, Colorado,** Lodge not only invited the Stray Elks, but their wives as well. The 76 guests were photographed as they enjoyed the roast beef dinner which was part of the program.



transfer to affiliate with the lodges near their new homes. Naturally, it is logical to expect some branches of the Order might have a decrease in membership through transfers resulting from this project, but from the remarks included in the reports sent to the Grand Lodge Committee it is obvious that the lodges are aware of the importance of bringing our Stray Elks back into the fold and that, with a maximum effort toward this end on the part of all lodges, their rosters should balance out quite nicely.

For example, Secretary M. D. Trace of Meadville, Pa., writes, "Since the first of February I have issued six transfer dimitts out and received four in. This leads me to believe that the program is being followed up by Secretaries throughout Elkdom. I know I like the idea and am doing all I can to keep in touch with Strays."

Exalted Ruler H. C. McLaurry of Burlington, Iowa, Lodge admits that "some other lodges apparently worked more diligently for we lost a total of 23 members and picked up only eight Stray Elks. However," he continues optimistically, "we feel that the program is a healthy step toward greater participation and progress and we are 100 per cent for it." All lodges reporting made it an all-out effort—officers and their wives were present to welcome the newcomers and in many cases dignitaries of the Order were also on hand. Past Grand Exalted Ruler Frank J. Lonergan addressed the 71 Strays entertained by Grand Esteemed Lecturing Knight D. V. Bulger and the other Elks of Portland, Ore.

The terrific promotion campaign put on by Membership Chairman Nick Carr made the Sacramento, Calif., event "not only a success, but a huge success," to quote Exalted Ruler Vernon E. Dole. The full-day program found nearly 150 Strays at a lodge session, initiation, reception and dinner.

These and the other Round-Ups represented here photographically, reflect the tone and atmosphere of hundreds of others, and as Phoenix, Ariz., Lodge's report stated, "We have learned much from the initial trial and are confident we can improve . . ."

This is the spirit Grand Exalted Ruler Wisely had hoped for when he reminded the entire membership of the Order that "Elkdom Follows The Elk".

**OLD TIMERS OF SPRINGFIELD, MASS.,** Lodge, No. 61, were honored for the fifth consecutive year at an outstandingly successful dinner and entertainment attended by 400 persons. The affair also observed "Stray Elks Night" when Exalted Ruler Edward J. O'Brien welcomed 28 residents of his city who hold membership in other lodges.

Each year this event pays signal tribute to one or more

**DURANGO, Colorado,** Lodge's "Round-Up" brought in some 30 Strays through every device known to man—a stretcher, wheel-chair, wheelbarrow, even a rope, as this photograph testifies.

of the lodge's veteran members. In 1958, for instance, Wm. B. Belli and Pat Casey shared the spotlight. The latter, the only living Charter Member of the 59-year-old lodge and long prominent in the theatrical world, was honored again this year when No. 61's senior Past Exalted Ruler, Past Grand Exalted Ruler James R. Nicholson, was selected as special guest and principal speaker by a committee headed by Charles J. Donovan. District Deputy Robert J. Armstrong also attended this affair for which Past Exalted Ruler Thomas F. Barry was General Chairman, assisted by sub-Chairmen Past Exalted Ruler Paul L. Keating, Robert F. Driscoll and John D. McBride.

**FLOOD-RAVAGED FREMONT, OHIO,** is about back to normal now, but the community will never forget the assistance given by the Elks of Fremont Lodge No. 169 throughout the horror-filled hours during which the Sandusky River raged through the city's main street twice in 22 days.

Undoubtedly the most heroic and unselfish member of the lodge is Henry W. Sprang, 72-year-old chef for the Elks of Fremont. Early in the morning of January 22nd he was awakened at his hotel and told there were men waiting at the lodge home for his assistance in preparing food for police, the military and others doing rescue and guard duty. He rushed to the club and worked there continuously for 25½ hours. During the next five days he never left the lodge home, on duty 143 hours with only 13 hours given to cat-naps. Coffee and food were available on a 24-hour basis, with 400 persons fed daily.

When flood waters struck again on February 10th, Henry Sprang was there to resume his duties. During the next 61 hours in which the river took over the city, he spent 59 of them in his kitchen.

This selfless devotion to his fellowman is in the best tradition of Elkdom. And not only Henry Sprang, but the entire membership of the lodge has received heartfelt thanks and highest praise from all sources.

Exalted Ruler Jack D. House headed the Special Rehabilitation Committee which organized teams from neighboring lodges to furnish truckloads of warm clothing, food and necessary equipment. With this outstanding teamwork, there wasn't a minute during the emergencies when relief was not available.



**COLORADO ELKS LARADON HALL** for Exceptional Children has a new addition, the John R. Coen Vocational Trades Building which was dedicated recently. Included in the photograph taken as Grand Trustee Jacob L. Sherman delivered the main address were Mrs. Coen, left background, and Grand Exalted Ruler Horace R. Wisely, right background.



**BEAUMONT, TEXAS,** Lodge is proud to be the first organization to sponsor an Explorer Post Skin Diver Division of Boy Scouts. E.R. V. J. Temple, Sr., has received the Charter from Dist. Comr. Ulys Morgan. Pictured above are the charter Skin Divers, left to right, David Sandifer, George Eicke, Ronald Boggess, Denny Miller and Robbie Cox. Through the courtesy of Elk Charles A. Thompson, the Post has at its disposal a 28-foot cabin cruiser, used extensively by the boys both for training in skin-diving and for pleasure.

**INDIANA ELK** dignitaries visited the Ind. Univ. Medical Center recently for a first-hand view of the various cancer research activities the State Elks are sponsoring. Pictured, below, left to right, are Past Grand Exalted Ruler Joseph B. Kyle, State Pres. Norman Freeland, Dr. John Van Nuys, Dean of the Center, and Past Pres. Thomas E. Burke, Chairman of the Ind. Elks Permanent Activities Committee.



**ELKS LARADON HALL** for Exceptional Children, long sponsored by the Colorado Elks Assn., has added facilities in the new John R. Coen Vocational Trades Building.

Dedicated by the officers of Sterling Lodge of which the late Past Grand Exalted Ruler John R. Coen was a member, the new building will be of tremendous benefit to the 70 children now enrolled. Grand Trustee Jacob L. Sherman delivered the dedicatory address.

Mrs. Coen was an honored guest at these ceremonies at which Grand Exalted Ruler Horace R. Wisely was another speaker, along with the Hon. Will F. Nicholson, Mayor of Denver where the School is located. The outstanding Greeley Elks Chorus sang several numbers during the program at which Duke W. Dunbar, Colorado's Attorney General and a Director of the Hall, presided. Other dignitaries on hand included State Pres. Dr. Leo Schneider and Past Pres. Byron A. Anderson.

**LONG-TIME ELKS** were among the 165 persons attending the special dinner held by Council Bluffs, Ia., Lodge, No. 531, in honor of its Old Timers and Past Exalted Rulers. Elks of more than 20 years' standing were the recipients of gifts, and 80-year-old A. N. Kolb accepted an Honorary Life Membership from State Pres. James Tait. The oldest Old-Timers on hand were Bert Clark, E. J. McKinley and I. B. Rohrer, all members more than 50 years.

Following a chicken dinner, a group of Past Exalted Rulers initiated a class of 12 candidates who were addressed by Mr. Tait and State Vice-Pres. Robert Weichman. Other dignitaries present were Past District Deputies Leo D. Gardner and Harry G. Burrell.

**AN EXCITING EVENT** took place in Joplin, Mo., recently when well over 500 Elks and their wives attended the 5th Annual Four-State Initiation meeting. In the afternoon a class of candidates from lodges throughout the Arkansas, Kansas, Missouri and Oklahoma area took the obligation of membership and in the evening a banquet was held. At that time, Grand Exalted Ruler Horace R. Wisely was the forceful main speaker, concluding his remarks with the statement that "the secret of our success in the Order is found in leadership".

Mayor C. C. Haynes was introduced by host Exalted Ruler Joe Ben Gold and brief talks were given by Past Grand Exalted Rulers Joseph B. Kyle of Indiana and Earl E. James of Oklahoma.

District Deputy Walter Schweikert, as General Chairman, introduced the



**LOGAN, West Virginia,** Lodge's officers who won the 1959 State Ritualistic Contest are, left to right, Candidate Harmon Maynard, Est. Lect. Knight M. A. White, Lead. Knight Ernest H. Williams, Jr., E.R. Harvey Weiner, Loyal Knight A. B. Ammar, Inner Guard Eugene Silvestrucci, Esq. Albert Klele, Jr., and Chaplain Dan D. Dahill.



Presidents of the participating State Associations—J. I. Malham of Arkansas, G. E. Edwards of Kansas, C. J. Ellis of Missouri and C. H. Dietz of Oklahoma—each of whom then presented his fellow officers. The initiatory ritual was handled expertly by a selected group of officers from the area, all of whom have won a first-place award in ritualistic competition.

Among the other Elk luminaries present were Grand Lodge Committeemen Guy D. Moore and Bert Wysor.

**L. A. LEWIS**, Past Grand Exalted Ruler, complimented the Elks of Fresno, Calif., Lodge, No. 439, on their wise and forward-looking approach in building to the future of the Order. This praise was contained in his talk delivered when the home of Fresno Lodge was dedicated by District Deputy W. C. Hanawalt.

The building, its furnishings and the land on which it was erected, represent an investment of \$550,000. With 30,514 square feet of floor space, the structure is located on a 16-acre tract four miles from downtown Fresno.

Past Exalted Ruler K. H. McIsaac was Chairman of the program at which Exalted Ruler D. M. Linder welcomed the lodge's many visitors.

**THE OVERNIGHT VISIT** of Elks of California's West Central District and their wives to San Luis Obispo Lodge No. 322 was an unqualified success. The occasion was a Clinic Meeting called by District Deputy John D. Morris for all Exalted Rulers, Est. Leading Knights and Secretaries, of the area. San Luis Obispo Elksdom had 104 visitors, all of whom were met at the station by a reception committee led by Exalted Ruler Joseph Limon, and taken to the lodge home by Transportation Chairman and Est. Loyal Knight Richard L. Simon.

Henry Gattaneo was General Chairman for the program which included sight-seeing trips for the ladies. In the evening a hard-working group of local members served a beef barbecue to their guests. Among them were Past District Deputies Ray A. Macaulay, M. N. Watters, L. T. Brazier, E. J. Silva and Paul Sanchez.

**A RATHER UNUSUAL OPEN HOUSE** program was held by Hotchkiss, Colo., Lodge, No. 1807, recently. In conjunction with the VA Hospital at Grand Junction, the Hotchkiss Elks sponsored the event for the purpose of securing blood for the patients of the VA Hospital, and also for St. Mary's Hospital in Grand Junction which needed blood to replace that used by a Hotchkiss Elk.

Grand Junction Lodge's Activities Chairman for the VA Hospital, G. W.

McFall, made the arrangements for this project, with the cooperation of Hotchkiss Lodge's Exalted Ruler C. G. Douglass, Est. Leading Knight W. E. Brown and Trustee Clement Audin, Jr., Past Exalted Ruler.

G. T. Grover, Blood Coordinator for the VA Hospital, with four assistants including two doctors from his staff, made the 60-mile trip to Hotchkiss to handle the operation. They were most enthusiastic in expressing their thanks for the success of the project—in two hours, 35 pints of blood were obtained.

**A COLLEGIATE FOOTBALL GREAT** was honored recently by Ansonia, Conn., Lodge, No. 1269. He is Nick Pietrosante, Notre Dame's highly honored fullback, and he handled the role of principal speaker at the lodge's 5th Annual Sports Night program with all the poise you'd expect of a star athlete in his own home town. Nick is an Ansonia boy, and an overflow gathering of over 200 packed the lodge home to pay tribute to him.

Following a roast beef dinner, Postmaster D. J. McCarthy, Exalted Ruler of the lodge, introduced the speakers, among them Mayor J. A. Doyle, local high school Coach Charles Jarvis, former Coach John Janenda, Arthur Forst, one of the early All-Americans from Villanova, and Joseph Pietrosante, Sr., father of the guest of honor.

**JOINING FORCES** with the Anti-Narcotics Committee, Torrance, Calif., Lodge, No. 1948, selected "The Terrible Effects of Narcotics" as the topic for its annual essay contest this year. Open to students of all junior and senior high schools of the District, the competition was sponsored by the lodge's Americanism Committee of which Paul L. Warren is Chairman and Lambert Brownlee is Co-Chairman.

With the cooperation of Curriculum Consultant Dr. Max M. Appleby of the School District, the competition was a great success, with over 100 essays submitted to a panel of seven judges. U. S. Bonds were offered as prizes.

Contestants were given the choice of writing 500 words on the effects of narcotics in the home, in the school or to the country in general, with five weeks for research and preparation of their papers. The first award of a \$100 Bond was won by John Butterfield; the second-place \$50 Bond went to Lenora Calitri, and the third prize of \$25 was awarded to JoAnne Bone.

**REDONDO BEACH, California**, Lodge's E.R. R. A. Miller extends a welcome to Andrew Halloran, a member of Framingham, Mass., Lodge and Grand Worthy President of the Fraternal Order of Eagles, at the banquet the lodge held in his honor.



**LINCOLN, Nebraska**, Lodge is proud of its new Memorial Tablet. After a year's research and planning, a committee of P.E.R.'s decided on this handsome Book of Memory as one which will fill the lodge's requirements for many years. The Book rests on a podium of white oak in a niche in the lodge's trophy room, before drapes of a light metallic fabric which enhances its beauty. Under its hinged door are five copper sheets with a capacity of more than the lodge's present membership of 2,200. The first page is now filled with the names of 440 Departed Members, dating back to 1912. At left is E.R. Wm. D. Quinn; at right is P.E.R. H. F. Herminghaus.



**MICHIGAN ELKDOM** is responsible for the happy smile on the face of Julia Bowles, 14-year-old polio victim. Because of a setback in her physical condition, Julia could not start her high school education. When Hillsdale Lodge's Handicapped Children's Committee Chairman Orrin H. Pibbles heard of her plight, he referred the problem to the State Elks' Major Project Commission. As a result, Elk Dist. Vice-Pres. Milton McKay, local manager of the Mich. Bell Telephone Company, arranged a 25-mile communication system to connect the girl's bedroom with her classrooms. The line goes through two exchanges and is channeled to four classrooms so she is in direct two-way contact with all her classes.





LAWRENCEBURG, Indiana



IRONWOOD, Michigan



TUSCALOOSA, Alabama



McALESTER, Oklahoma



TEMPLE, Texas



WILLMAR, Minnesota



CHIPPEWA FALLS, Wisconsin



NATCHITOCHEs, Louisiana

... The LAWRENCEBURG, IND., class initiated in honor of State Pres. Norman Freeland is pictured with E.R. J. C. Klum, third from left.

... IRONWOOD, MICH., Elk officials are pictured when E.R. T. O. Rowe, fifth from left, background, presented to Director R. A. Burns of the Mich. Elks' Major Project Commission, the check representing the lodge's 100 per-cent cooperation in the Project. In the foreground are three initiates.

... TUSCALOOSA, ALA., Lodge's E.R. H. C. Van Buskirk, left, presents an Elk's pin to his newly initiated son.

... McALESTER, OKLA., Lodge's \$500 check for training films for the six-county Choctaw Area Boy Scout Council is presented by E.R. R. E. Slayton, third from left, to Scout Exec. Warren Green. Looking on, with two Elk-sponsored Scouts, is Scoutmaster Richard Vegher, Est. Loyal Knight.

... TEMPLE, TEX., E.R. J. W. Zvolanek, left, presents the Elks' annual Football Awards to Wren Dillard, Best Defensive Lineman, and Kirby Richter, Best Offensive Back.

... WILLMAR, MINN., Lodge's devoted 38-year-member Victor Persohn presented this original Les C. Kouba painting to the lodge recently.

... Pictured when CHIPPEWA FALLS, WIS., Lodge presented a TV set to St. Joseph's Hospital were, left to right, Dr. J. J. Sazama, Sister Miriam Joseph, Hospital Superior, and Dr. B. J. Haley.

... NATCHITOCHEs, LA., P.E.R. G. H. Himel, left, Chairman of its Southern Eye Bank Fund, presents to E.R. H. S. Cobb a check for the State Assn.'s Eye Bank Fund, to bring the lodge's total contribution to \$2,225.

. . . ELIZABETHTON, TENN., Lodge's tribute to State Pres. W. J. M. Barron was marked by the initiation of a group of candidates, one of whom was J. H. Fletcher, Sr., third from left, foreground, father of E.R. R. J. Fletcher, fourth from left. Others include the officers, background, and initiates Ralph Cole, Ralph Davis and Walter Shaffer.



ELIZABETHTON, Tennessee

. . . DOWAGIAC, MICH., Elkdom's first annual Civic Award is presented to Circuit Judge Carl D. Mosier, seated, by E.R. C. R. Davis. The widely known jurist retires this year.



DOWAGIAC, Michigan



JOPLIN, Missouri

. . . JOPLIN, MO., Lodge's E.R. Joe Ben Gold, left, presents his lodge's check to Sister Mary Austin of St. John's Hospital. The money will be used to purchase a dehumidifier for Elkland, the children's ward of the hospital which has been equipped by the lodge since its inception in 1953. Looking on, left to right, are Est. Lect. Knight Richard Berry, Lead. Knight Arthur Struempf, Chairman of the lodge's Welfare Committee, and Grand Lodge Committeeman Guy D. Moore.



MINOT, North Dakota



FREEPORT and GALENA, Illinois

. . . MINOT, N. D., Lodge's E.R. Roy A. Ilvedson, right, presents an Honorary Life Membership to P.E.R. R. K. Olson, for his outstanding service.

. . . FREEPORT, ILL., Lodge entertained GALENA Elk officers when the visitors initiated a class for their hosts. Pictured as the gavel changed hands were, left to right, Freeport Est. Lead. Knight R. M. Smith, Galena E.R. F. R. Vincent, Freeport E.R. Herbert Faber and Galena Est. Lead. Knight E. V. McDermott.



HARTFORD CITY, Indiana

CICERO-BERWYN, Illinois

. . . HARTFORD CITY, IND., Lodge celebrated P.E.R.'s and Old Timers Night with a guest list of 60 veteran Elks. Each received a special pin from 37-year-Elk C. R. Gough.

. . . CICERO-BERWYN, ILL., E.R. H. J. Cerwin, left foreground, receives an Elks National Foundation Permanent Benefactors Certificate from D.D. R. B. Baudin, right. In the background are P.E.R.'s A. G. Jaros and G. W. Nemece, J. A. Fencl, J. F. Kral and John Soukup, lodge Trustees.





**A FOUR-STATE INITIATION** ceremony at Joplin, Mo., found this group of candidates becoming members of lodges in Arkansas, Kansas, Missouri and Oklahoma in the presence of many dignitaries. Among them were Grand Exalted Ruler Horace R. Wisely, center foreground, and Past Grand Exalted Rulers Joseph B. Kyle, on Mr. Wisely's right, and Earl James, on his left.



**ANSONIA, Connecticut**, Lodge held a Sports Night program recently when Nick Pietrosante, Notre Dame football star and a home-town boy, was the principal speaker. Pictured on that occasion were, left to right, foreground, E.R. Daniel J. McCarthy, Toastmaster; Nick Pietrosante and his father, Joseph Pietrosante, Sr.; standing are Arthur Forst, a gridiron luminary of 40 years ago, Committee Chairman and Inner Guard Robert J. Ferguson, Mayor Joseph A. Doyle and Ticket Chairman Joseph Y. Miller.



**JOLIET, Illinois**, Elksdom has been assisting a dedicated group of mothers and teachers in maintaining a small school for retarded children of the community, through the sponsorship of an annual Charity Ball. Under P.E.R. Jack F. Sullivan, \$2,000 was raised the first year, with a total of well over \$10,000 realized for the project during the five years the Ball has been held. Left to right are P.E.R. W. J. Stewart, Mrs. Steve Marinkovich, E.R. William L. Carey, D.D. R. B. Baudin and P.E.R. Sullivan.

## LODGE NOTES

Three-year-old Fullerton, Calif., Lodge has a new building under construction. Its current membership is 2,000 and it anticipates a potential roster of 3,000. Secretary W. P. Osenbaugh informs us that his lodge is looking for a first-rate, well-qualified Club Manager to take care of its new home and invites interested readers to write him giving full details, including salary requested and references. Address these applications to Mr. Osenbaugh, P. O. Box 136, Fullerton, Calif.

It is with deep gratification that we take note of the stamped legend now gracing the envelopes carrying mail from Staten Island, N. Y., Lodge. This stamp reads:

Patronize the Advertisers  
in The Elks Magazine  
Only the best quality products  
are shown therein.  
**THE MAGAZINE NEEDS YOU: WE  
NEED THE MAGAZINE.**

This outstanding cooperation with the Order's official publication is most commendable, and extremely helpful.

Towson, Md., Elksdom has lost a loyal member in the recent passing of Frank I. Wheeler, Sr. A Charter Member of this lodge, Mr. Wheeler was its first Est. Loyal Knight and served as its third Exalted Ruler in 1900-01. He had also been a Trustee for several years and was elected to Honorary Life Membership in 1945.

Teams from Delta, Montrose, Cortez and Durango recently participated in the Colo. S. W. Dist. Double A High School Basketball Tourney in Durango. After the two-day competition was completed, the Durango Elks held a "Teen-age Dance" open to all youngsters from all areas of the District. Over 400 teenagers attended.

Quincy, Mass., Lodge celebrated Past Exalted Rulers Day and observed its 54th Anniversary with the initiation of 15 candidates. Among them were the three sons-in-law of Past Exalted Ruler Larry Antonelli, who served as Exalted Ruler during the ceremony. Each initiate received an Elk's lapel pin from Exalted Ruler L. M. Foley.

When the Eldred Sunset Manor Foundation dedicated the \$1,300,000 first wing of the \$2,500,000 Eldred Chronic Diseases Hospital in Central Utah recently, members of the Order played prominent roles in the ceremony. First of all, L. J. Eldred, who, with his wife, created the Foundation four years ago, has been a member of Provo, Utah, Lodge for 55 years. Secondly, Seth Billings, who is President of the non-profit Eldred Foundation, is also a prominent Provo Elk and served as Grand Tiler in 1957-58.

Minot, No. Dak., Lodge has two noteworthy members. Paul V. Barber handles the lodge office during the evening, taking all phone calls, collecting dues and parking rentals, and addressing all lodge communications, even though he is blind. He is also Vice-President of the Elks Quarter Back Club. Deeply interested in sports, Mr. Barber was a fine athlete before he lost his sight. Minot Elks are also very proud of A. E. Tooley. Initiated in May, 1911, he has served his lodge as Treasurer for 44 consecutive years.

# Tom Wrigley

## WRITES FROM WASHINGTON

**U. S. BUILDS IN BERLIN.** Just to let Russia know we intend to stay in Berlin, the Defense Dept. is now building more apartments for U. S. military personnel and their families there. A new project now started in Berlin will add 116 family units, making a total of 368.

**BIGGEST ELEPHANT.** Spring crowds at the Smithsonian Institution stare goggle-eyed at the mounted hide of the world's biggest elephant. The trophy is in the rotunda of the National History Building. The elephant was shot in Southwestern Africa in 1955 and weighed over 12 tons. It stands more than 13 feet high. The tusks of the elephant weigh more than 100 lbs. each. J. J. Fenykovi killed it after a day-long battle. It took 19 bullets from a .416 caliber rifle. The elephant's skin alone weighed more than two tons. Jumbo, the former champion elephant, was 20 inches shorter.

**TAX PAYMENTS IMPROVE.** Now that the Federal income tax deadline has passed, Treasury experts are hoping the returns will show a further decrease in delinquent tax payers. Last year there were 1,280,642 owing \$1,375,737,000. This compares with 1,554,876 tax payers who owed \$1,504,709,972 at the end of 1957.

**U. S. SENATORS** have better protection under new rules, just issued for the Senate wing of the Capitol. No person is allowed into the galleries carrying any package, bundle, suitcase, briefcase or camera. There is no smoking, applauding or demonstration of any kind. There can be no note-taking or sketching, except by correspondents in the press gallery. No object of any kind can be placed on the gallery railing. Rules against smoking have been modified, however, and smoking is now permitted in the corridors and passageways of the Senate wing. Senators, under the new rules, cannot bring friends on to the Senate floor when the Senate is not in session and permit them to sit at the desks of famous colleagues.

**JOBS FOR OLDER PEOPLE.** Small Business Administration, in a survey by Harry David, of under-used sources of employees, declares jobs for workers 45 years and over are bound to increase. In the decade ahead, the survey says,

10,000,000 new workers will be needed and employers will look to "older" employees to fill part of the gap.

**PROBES AIR TRAVEL.** Too many Government workers are using de luxe plane flights between the U. S. and Europe, Rep. Tollefson of Mich. declares, in requesting an investigation. Round trip fare on "champagne" flights is \$903.40, while the economy rate is \$478.70, Rep. Tollefson said.

**NEW HOSPITAL PLAN.** The rising cost of hospital care has finally won the attention of Congress. Among the bills now before the House is one by Rep. Aime J. Forand of R. I., which would extend hospital and nursing home care to Social Security pensioners. It would provide up to 60 hospital days a year and would also cover surgery. To finance it, Social Security taxes would rise an added \$12 a year and each employer would match this for every worker.

**ROBOTS SORT MAIL.** In Washington's new City Post Office, a cancelling machine handles 30,000 letters an hour. A semi-automatic mail sorter can route 14,400 packages an hour to 32 destinations. There are five miles of conveyor belts. The automation cost \$12 million.

**HUSH-HUSH C. I. A.** Central Intelligence Agency is so super-secret that wives of workers in the place don't even know what their husbands do. When one prospective juror was asked about friend husband in C. I. A., she said, "I don't know what he does and I don't want to know." She did admit, however, that, before he took the job, he inspected eggs. "Well, maybe he inspects eggs for C. I. A.," the judge commented.

**YOUR MAIN STREET,** like mine, is facing trouble. Buying habits of the American people have changed rapidly in the last few years and super-shopping plazas are getting the play. Merchants here and owners of real estate are plainly worried. Within recent weeks, two additional huge suburban shopping centers have opened. One, the \$1 million Prince Georges Plaza, has 4,000 free and easy parking spaces on all sides. There are 32 modern stores. The other giant shopping center, the Congressional Plaza, covers five city blocks and has over 300,000 square feet of floor space. It



TOMMY WEBER PHOTO

too has free parking space for thousands of cars. Various lines of business which maintain national headquarters in Washington are seeking a solution of the problem. In Washington, the downtown stores have banded together to provide free parking at garages and lots.

**OLDEST NEWSPAPER.** As a real, honest-to-goodness American newspaper, *The Alexandria Gazette*, now beginning its 175th year, is in a class by itself. It is this country's oldest newspaper and, in its recent anniversary edition, printed 128 pages. Editor Charles C. Carlin, Jr., has been receiving congratulations from readers throughout the nation. President Eisenhower said, "The files of the *Gazette* are an invaluable source of American history." Late Past Grand Exalted Ruler Robert S. Barrett was at one time Editor and Publisher.

**CAPITAL CHERRIES.** Senate Republican Leader Dirksen says Senators talk too much about Berlin and other trouble spots. . . AFL-CIO's one-day unemployment mass meeting here cost about \$500,000. . . Radioactivity is increasing in Washington because of Russian nuclear tests but is still far below the danger level, Public Health Service says. . . America has 3 million men in its reserve forces, Defense Dept. told Congress. . . Marriages have been decreasing for the past two years and the rate is now down to 8.3 per 1,000, compared to 9.4 in 1956. . . Boy Scouts here ordered an \$8.50 cake and, by mistake, the baker produced one three feet high, price, \$85, but the baker paid the difference. . . A \$213,000 water sports center has been held up because of water pollution. . . The District now has over 666,000 government workers, of which 666,000 drink coffee at 10 a. m.

# SOME FACTS AND FALLACIES

Despite thousands of years of association between men and dogs, we still cling to many misconceptions about the canine species

By **ED FAUST**

BASSET HOUND PHOTO BY PHILIP GENDREAU



AMONG the many mysteries insoluble to me is how little man knows about dogs although archeological evidence points to nearly 10,000 years of association between the two. That's a long time on anybody's calendar other than the anthropologist, to whom this is a mere fragment of the past and who assures us that remnants of Fido have been found in the caves of his Stone Age masters.

Now you'd think that such long association, out of which came the affection that exists among men and dogs would have endowed the former with much better understanding of the latter; but the world still awaits the individual who can prevent the not at all uncommon dog disease, distemper. Aside from those tolerated persons who tell shaggy dog stories who, who in all the world, really understands dog language? No, our four-legged friend still remains pretty much a mystery, which accounts for the many misconceptions and superstitions that persist among many otherwise well informed people. You wouldn't believe it, of course you wouldn't, but it's a fact that there are those who think a sure test of a pure bred dog is to pick him up by the tail. If he yelps he's no blue-blood.

Others will tell you that feeding sweets to Fido will give him internal parasites. Unless the wigglers are on the candy or such-like, Fido isn't capable of creating them on his own. And milk, innocent milk—I've been assured by several people who claim to know all about dogs, that milk given to puppies will always, yes, always have the same effect. Nonsense? Not to the folks who believe it.

Notwithstanding the fact that the dog is a carnivorous animal, a meat eater from his jungle days, there are citizens who hold that this nutritious food will start any dog on the warpath. Another twisted thought is that the purp possesses an instinct for chasing cats, that both critters have been enemies from way back. Webster says instinct is a hereditary factor in behavior. If this is so then countless generations of dogs have inherited the impulse to chase horses, cattle, automobiles and small boys and girls on bicycles. The only instinctive element is that many dogs will chase anything moving across their lines of vision or away from them. A cat is usually shy, while Fido is quite the opposite.

Sometimes it's difficult to separate a superstition from a simple, firmly held misconception, and here's a wrong-headed opinion that has to go begging for a label. It is a common idea that the dog of mixed breeding is smarter and healthier than the aristocratic pooch. The dog of unknown ancestry simply represents a survival of the fittest. His folks had to be smart to stay alive and healthy enough to survive to become  
*(Continued on page 37)*

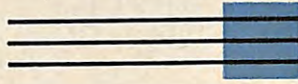

## FROM OUR READERS

I have just finished reading Al Stump's "Baseball: Better Then or Now?" in the February issue, and I enjoyed it very much. It looks to me as if the old timers got the best of it. Give us more of the same.

To bring up a much discussed subject, what about the matter of standardizing the baseball outfield? This improvement is long overdue and, actually, the present artfully arranged outfields are a disgrace to the great game of baseball. Isn't it about time for something to be done to remedy this? The infield is standardized; the football field is standardized; the tennis court is standardized, and so on and on. Yours for better baseball.

AUSTIN, TEXAS WARREN S. FREUND

I enjoy reading THE ELKS MAGAZINE very much, especially the articles on do-it-yourself projects which appear each month in Harry Walton's department, The Elks Home Workshop.

OAKMONT, PA. ANDREW BORDY

Let me take this opportunity to thank the members of your Travel Department and the Sinclair Refining Company for their cooperation and for the information they gave us, which made our last vacation a successful one.

When we traveled over the routes that were marked out for us, we knew that we would have miles of pleasant traveling.

BUTLER, PA. H. V. PACOE

I wish to express my sincere gratitude for the very prompt and thorough information I have received from the Travel Department of THE ELKS MAGAZINE.

As a member of the Order in military service, I have not been as actively engaged in lodge work as I would like, but I am looking forward to it upon my retirement from the United States Coast Guard in 1961 or 1962. I have always enjoyed THE ELKS MAGAZINE, but was not aware of the excellent travel service offered.

CHICAGO, ILL. ROBERT E. BONVILLE

*It is always a gratifying experience to find that the reaction of readers to a series of articles is enthusiastic. The*

*following are some of the letters that have been received in response to such a series—the articles concerned with the many aspects of small business, designed to be of aid to the great number of Elks who are small businessmen.*

We wish to compliment you on the article in the March issue—entitled "Program for Protection"—dealing with insurance for business concerns. We believe the article should be helpful to a great many merchants and other businessmen.

However, we would like to clarify the application of the co-insurance clause discussed by the author, Eugene Rachlis. This clause states that: "The insured shall at all times maintain contributing insurance on each item of property covered by this policy to the extent of *at least* the percentage specified." In other words, the percentage of co-insurance stated in the policy shall be a minimum amount, and *at least* that much must be carried. We thought possibly you might like to have this brought out. Again, we wish to compliment you on the article.

SALINA, KANSAS OTHO SCHMIDT

I have only been an Elk for one year, but I would like to say that the small business articles which have appeared in THE ELKS MAGAZINE are well worth reading for any businessman, regardless of the type and size of his enterprise.

DERRY, PA. JOE E. GREUBEL

We very much enjoyed the Eugene Rachlis article—"Program for Protection"—in the March issue.

ST. PAUL, MINN. D. F. TUCKER  
INSURANCE MANAGER  
HAMM BREWING CO.

I have found all of the articles on small business very helpful and enlightening. I hope that you will continue featuring them in future issues.

SALT LAKE CITY, UTAH MORRIS ROSEN

We enjoyed the article "Government Regulations and Small Business" by Dickson Hartwell—in the April issue—and hope that there will be more of such articles in the future.

INDEPENDENCE, ORE. A. F. OPPLIGER

## Time for a Checkup?

Who knows, maybe it is. You get checkups on everything else — your health, your kids, the car.

So why not your investments, too?

After all, times change—and so do security values. The stocks you bought five years ago may have been just fine for your purposes *then* — but what about now?

Maybe your objectives have changed.

Maybe other stocks offer far better opportunities.

Maybe there are definite weak spots here and there in your portfolio.

That's why we think every investor should get a good financial checkup from time to time . . . find out just what his investment program looks like to a practiced, impartial observer.

And if you'd like to know what *we* think of the stocks you own, we'll be happy to tell you.

Our Research Department will mail you an objective review of your present portfolio, give you all the facts they can about any particular stocks you may want to buy or sell, or prepare a complete investment program for any sum, any objective.

There's no charge for this service, either. Whether you're a customer or not.

If you'd like an investment checkup, just write us a letter about your situation. You simply address—

ALLAN D. GULLIVER  
Department E-42

**Merrill Lynch,  
Pierce, Fenner & Smith**

INCORPORATED

Members New York Stock Exchange  
and all other Principal Exchanges

70 Pine Street, New York 5, N. Y.

Offices in 112 Cities

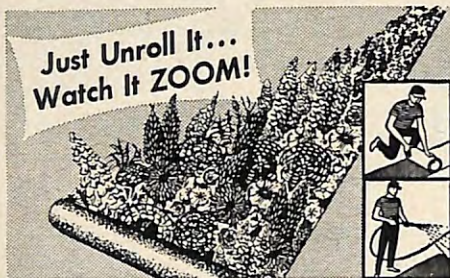

Just Unroll It...  
Watch It ZOOM!

Blooms as 17 Foot Carpet of Flowers!

## JIFFY PLANTER ONLY... \$1

Jiffy Planter Roll-Out Garden automatically plants over 1,600 choice annual seeds, nestled in the miracle Cellu-Mat growing medium. Cut to any size, plant anywhere! No mulching! No transplanting! No weeding! Sprouts in days. Blooms like magic in less than 6 weeks. Produces a solidly massed living rainbow of giant flowers, all Summer long! 25% larger than any other flower carpet at this price!

17 Ft. Flowering Carpet—giant Asters, Marigolds, Petunias, Zinnias, Poppies, Snapdragons, etc., etc.—\$1.00 postpaid.

17 Ft. Carpet Border—grows dwarfs less than 10" high—lovely Sweet Alyssum, Portulacas, Petunias, etc., etc.—\$1.00 postpaid.

Any 5 Carpets—\$4.90 postpaid

Complete satisfaction guaranteed or money back!

**SPENCER GIFTS** 252 Spencer Building, Atlantic City, N. J.

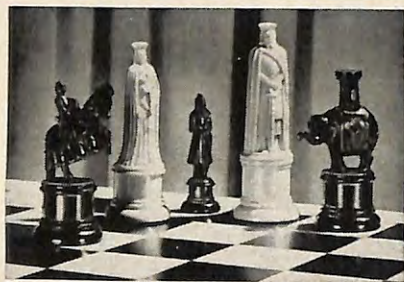

### Famous FLORENTINE CHESSMEN!!!

This is a beautiful, authentic replica of 11th Century hand-carved chessmen originally owned by Cosimo de Medici and now on display in the Uffizi Palace in Florence. Each piece, fashioned in simulated ivory, heavily weighted and felted. The King stands over 4 inches high. A perfect gift of elegance. Complete 32 piece set now on sale at \$7.95 plus tax, postage & handling. No C.O.D. please. Chess Boards available \$4 & \$12.00.

SAVAH BOX 27648 EL 1, LOS ANGELES 27, CAL.



### PORTABLE "SUN-FLECTOR" SOLARIUM

Give your entire body a "glow" of health year 'round in complete privacy! Scientifically designed, induces even tanning. Metalized, laminated inside surface reflects and spreads sun's rays from head to toe. Can also be used indoors with sun lamp. Outside is decorated in gay red and white candy stripes. PERSONAL

Model is 5 ft. long, 2½ ft. wide, 1½ ft. high. FAMILY Model is 7 ft. long, 5 ft. wide, 1½ ft. high. Both fold to a mere 18" x 30". Easy to carry or Store.

Personal Solarium ...\$5.00 Family Solarium .....\$8.00

ELRON INC., 352 W. Ontario, Dept. C-263, Chicago 10



EARLY  
AMERICAN  
MINIATURE!

### HOBNAIL MILK GLASS LAMP

\$7.00  
plus 25¢ post.

This authentic reproduction of an Early American Hobnail Milk Glass Hurricane Lamp makes a charming addition to any home. Stands 6½" high. Its milky white ceramic beauty is accented by gleaming brass fittings. Burns 4-5 hours with kerosene filling. Use also as an AIR FRESHENER—fill with deodorizer and turn up wick. Blends with all home decors. Swell gift—order several for yourself and friends!

Send for free gift and gadget catalog  
MOTHER HUBBARD, Dept. E-87  
10 MELCHER ST., BOSTON 10, MASS.



# ELKS



**HAND-LACED MOCCASINS** in over 223 sizes for women with hard-to-fit feet. They're choice leather with bouncy foam crepe soles for casual, comfortable wear by the gal who likes to hike, or relax indoors. Red, smoke, taffy tan and white. Full and half sizes 3 to 13, AAAAAA to EEE widths. \$5.95 plus 50¢ post. Moccasin-Craft, 65-EF Mulberry St., Lynn, Mass.

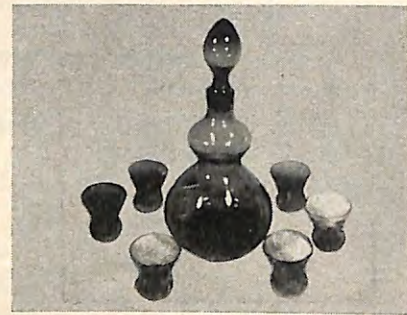

**VENETIAN LIQUEUR AND BRANDY SET** in beautiful rainbow colors. Made of famous Venetian glass, the set consists of 6 glasses in 6 different colors and a graceful decanter in one of the colors (amber, turquoise, blue, smoke, green and amethyst). Decanter is 10 in. high. Set, \$4.95 ppd. Edward H. Ziff, Importer, Box 3072, Merchandise Mart Plaza, Dept. E, Chicago 54, Ill.



**IT TAKES A TALL MAN** to wear these shirts with bodies cut 4 in. longer and exact long sleeve length. King-Size, a specialist in clothes for the big, tall man, has sports and dress shirts from \$5.95; shoes in sizes 10 to 16, widths AAA to EEE; large-size jackets, sox, slippers, slacks. Write for free catalog to King-Size, Inc., 134 Brockton, Mass.

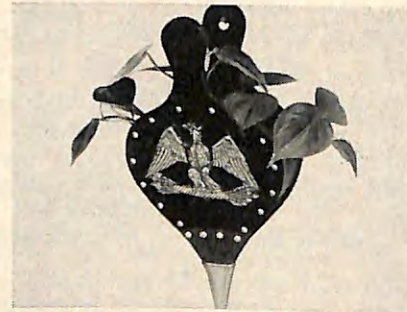

**COLONIAL BELLOWS PLANTER.** Lovers of nostalgia will delight in this charming reproduction of an early American antique that's both a roomy planter and an attractive wall decoration. Black styron with raised American eagle design in gold. 11½ in. high, 5½ in. wide, 3 in. deep. \$2.95 plus 35¢ post. Mother Hubbard, 10 Melcher St., Dept. E-94, Boston 10, Mass.

Merchandise shown on these pages can be ordered direct from the companies listed. Enclose a check or money order.

### MINNETONKA STRAWBERRY GARDEN

GROW MORE QUARTS  
OF STRAWBERRIES IN  
60 TO 90 DAYS IN A  
5 FOOT AREA



BUY DIRECT!  
Send Check Or  
Money Order!

### NEW, STRONGER CORRUGATED ALUMINUM!

Adds interest and beauty to your garden. Produces a bigger, better crop. 5 ft. size just right for 50 plants. ONLY \$8.95 ppd.

SPECIAL! 5 ft. corrugated aluminum garden with 50 Superfection Ever-bearing Strawberry plants. Complete ONLY \$10.95 ppd.

**MINNETONKA Nurseries**  
DEPT. ES EXCELSIOR, MINNESOTA

Send for  
Free  
Style Book!



### YOUR OLD FUR COAT STOLE \$22.95 Tax Free

I. R. Fox, fur specialist, restyles your old, worn fur coat regardless of condition, into a glamorous new cape or stole. Remodeling service includes cleaning, glazing, repairing, new lining, interlining, monogram. Allow two to three weeks for delivery. \$22.95 complete. Send no money! Just wrap up your old fur coat, mail it to us now. Send your dress size and height on postcard. Pay postman \$22.95 plus postage when new cape arrives. Or write for free style book  
I. R. FOX, 146 W. 29th St., Dept. K-30, N. Y. 1



# FAMILY SHOPPER



**RECLINO SPECS.** You can lie flat on your back and still enjoy "upright vision" when wearing a pair of Reclino Specs. Reclinos can be worn with or without glasses, give clear right-angle vision to read or watch television. They're especially helpful for anyone confined to bed. Reclino Specs, \$4.95 ppd. Jackson Products, 414-A East 75th Street, New York 21, N.Y.



**MINIATURE FLOWER FROGS.** You can arrange small bouquets in your favorite tea cup, wine glass, toby mug with these tiny frogs to hold them in place. English import has suction cup bases that stick firmly. 2½ in. high, ideal for short stem flowers. Set of 3 (2 var. of round, 1 oval), \$2.25 ppd. Artisan Galleries, 2100 N. Haskell Ave., Dept. E, Dallas 4, Tex.



**IT'S THE RIPPLE SOLE** on these Cavana Sandals that make them so comfortable to wear and so good for your feet. As you walk, the ripples gently massage your soles and absorb heel shock to reduce foot fatigue. In genuine natural color water buffalo. For ladies and men, sizes 3-13. \$9.65 ppd. Bloom's—"Down In The Village," 311-Sixth Ave., Dept. E-609, New York 14, N.Y.



**CIRCUS CANDLES . . .** What fun to decorate the birthday cake with 15 performing animals and merry clowns in assorted colors—blue, pink and yellow. Long-burning candles make novel party favors, place cards, and table decorations too. 2½ in. high. Complete set of 15, incl. 5 clowns and 10 animals, \$1.00 ppd. Sunset House, 75 Sunset Bldg., Beverly Hills, California.

*Except for personalized items, there is a guaranteed refund on all merchandise returned in good condition within 7 days.*



## MORE BRILLIANT THAN DIAMONDS

**MAN-MADE MIRACLE** gemstones—Titania—make ideal gifts for giving and getting all thru the year. For settings of your choice only \$12 per carat; a 1-ct man's box ring in 14K is \$32; 1-ct fishtail for m'lady is only \$25. Prices plus 10% Federal tax. Free, handy ring size chart and brochure—full of Regent Star Sapphires and Rubies and other man-made jewelry stones are available on request to:

**REGENT** Lapidary Co. Dept. E-62

511 EAST 12 STREET • NEW YORK 9, N. Y.

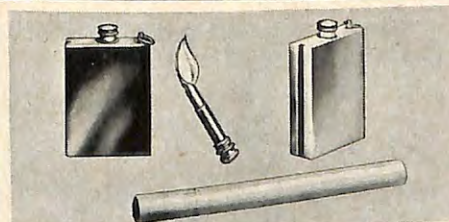

## LIFETIME 'MATCH' NEVER FAILS—69¢

New "everlight" match can't miss. Pull the permanent metal match out from its thin case, strike it on the side—*it's lit*. Put match back in case to extinguish. An amazing new lighter! Lasts for years. It's petite and thin—only 1¾" high. Has a small ring for key chain. Sensational! *Guaranteed to please or your money back!* PERMANENT MATCH only 69¢ each, postage paid, or two for \$1.25. Order from Sunset House, 2841 Sunset Building, Beverly Hills, California.

FELLMAN LTD.

Burnt Ivory

CHUKKA BOOT



*For The Fortunate Few Who Appreciate The Very New!*

Everything about this shoe is new... except its genuine moccasin comfort! The meaty leather is superbly mellowed, and hand-finished to an antique *burnt ivory* that grows richer with age! Hand-moulded by Taylor's Down-Maine craftsmen—and embellished with genuine hand-forged buckles, these shoes are an adventure in fashion and an experience in unequalled comfort!

Sizes 6 to 12, widths AA to E... \$19.95

ORDER BY MAIL—give exact shoe size, satisfaction guaranteed. Please add 45¢ for shipping.

FELLMAN LTD. 49 W. 43 N.Y. 36, Dept. A also 6 E. 46 St. NYC and Newark, N.J.



## exclusive RIVIERA ½ SLEEVE SHIRT

Made exclusively by Lew Magram, "Shirtmaker to the Stars". This eyelet, Schiffl embroidered, imported batiste, is utterly magnificent; a fashion masterpiece down to the scalloped half sleeves. An ideal shirt for spring and summer wear... now available, for the first time, to you! **IN STOCK.** White. Reg. sizes; S-M-L-XL. Tall men who need extra long body and sleeves, specify neck size and word **TALL**. \$9.95.

Send check or M.O. No C.O.D. Member Diners' Club and American Express Charge Plans.

Write for free catalog "Lew Magram's Conversation Creations in Men's Fashion."

**lew magram**

830-7th Ave., Dept. RK 5, N.Y. 19



## NEW PATIO MOCCASINS... \$4.95

Smooth, glove-leather with really light-weight, flexible cushion crepe soles to make walking a pleasure indoors and out. Black, White, Red, Saddle-Tan, Natural or Turquoise. Sizes 4-10, medium & narrow, half sizes too. \$4.95 plus 35¢ postage. No C.O.D.'s. **OLD PUEBLO TRADERS,** Box 4035, Dept. EPM Tucson, Arizona



## A PEARL IN EVERY OYSTER!

WE GUARANTEE IT!

What a thrill to find a pearl! And, you will! Each oyster is **UNOPENED** and GUARANTEED TO CONTAIN A CULTURED PEARL—perhaps of surprising value! Have your treasure set into a ring, pin, pendant. Shells are lined with precious Mother-of-Pearl: use them for ash trays, decorative pieces! Attractively canned, 1 oyster to can. Terrific for party gifts!

**\$1.25** YOUR MONEY BACK IF NOT DELIGHTED! ppd. per can; 3 cans \$3.60; 5 cans \$5.95

**CARTER GIFTS,** DEPT. EL 59, PLYMOUTH MEETING, PA.



**Just Unroll It...  
Watch It Grow!**

**MAGIC 16 FOOT  
FLOWER  
CARPET \$1**



Amazing MAGIC FLOWER CARPET automatically plants a 16-foot garden of premium annuals. Over 1500 pre-planted seeds are impregnated into a 16'x6" carpet. Can be cut to any size. Simply unroll, water, and watch it burst into gorgeous blooms. In 6 weeks you have a close-massed riot of flowers. Marigolds, petunias, asters, poppies, snapdragons, zinnias — more than 25 varieties in all. *Guaranteed to give you a prize-winning garden or your money back.* Only \$1, postage paid — 3 for \$2.79. Order MAGIC FLOWER CARPET direct by mail from **Sunset House, 408 Sunset Building, Beverly Hills, California.**



**1959 MODEL  
DOUBLE WINDOW  
WATCH**

FOR  
INSTANTANEOUS TIME IMPRESSION

Precision workmanship. Rugged Shock-Resistant Case. Automatically shows both hour and minute reading. No need to follow both the hour hand and the minute hand the old fashioned way to see the time. Jewelled. Guaranteed for one year for both parts and labor. Watch band included.

Introductory price **ONLY \$9.95**

Send check or money order or sent C. O. D.

**CRYDER SALES CORP.** Dept. WW-67  
Box 79, Whitestone 57, N. Y.

**WORLD'S FINEST LOWEST PRICED  
ADDING MACHINE**

Counts Up to 999,999,999

Made in America By Americans  
Ideal For Business And  
Personal Use—Guaranteed Accurate.

Not a toy. Operates with only a finger flick. Adds, subtracts, multiplies, divides. Counts up to one billion. Pays for itself over and over. Ideal Gift —for Business, Income Tax and School use. **MONEY BACK GUARANTEE.** Send name and address. Pay postman only \$2.95 plus postage, if check or M.O. we pay postage. Beautiful rich-looking Leatherette Case included at no extra cost. Money back in 10 days if not delighted. **AGENTS WANTED.**

**CALCULATOR MACHINE CO., (Mrs.)**  
Box 126, Dept. T-97, Huntingdon Valley, Pa.



**VEST  
POCKET  
SIZE  
FREE  
TRIAL**  
**\$2.95**  
\$3.04 in  
Penna.  
Incl'g  
Tax



**KEEP YOUR CANINE DRY...**

Logged out in a snappy raincoat made just for him (or her). This fashionable model is clear plastic trimmed in red and inscribed with your proud pet's name. It's made in 12, 14, 16 and 18-inch lengths (measure from neck to tail). Send dog's name, measurements and \$1.29 ppd. to:

**H. HOLLAND**  
Dept. E5, P. O. Box 75, Brooklyn 3, N. Y.



**ELKS**



**KENYA GEM . . .** a scientist's creation that has all the dazzling whiteness and fiery brilliance of a real white diamond. These miracle gems are set in men's and ladies' rings for as low as \$54, incl. tax, or on payment plan for as little as \$6 down. Write for free booklet showing wide ring selection. Kenya Gem Corporation, Dept. ES, Philadelphia 44, Pa.



**JR. PILOT AND STEWARDESS CAPS** for boys and girls 3 to 12, are exact copies—in style, color and insignia—of major airlines' caps. Adjustable, one size fits all. Specify Pan-Am, Braniff, Western, Continental, Eastern, Delta, Capital, Northeast, National, Northwest and United. \$1.98 ea. ppd. Lord George, Ltd., 1270 B'way., Dept. E, New York, N.Y.



**PULLOUT CLOTHESLINE** has up to 55 ft. of line for indoor or outdoor use. Just hook unit to wall, post, door, etc. (no tools necessary) and pull out 4 strong plastic lines to length needed. Lines can't sag, stretch or tangle. Handy clothesline fits anywhere, even in small rooms or corners. \$2.89 ppd. Nouvelle, 352 West Ontario Street, Chicago 10, Ill.



**CULOTTES FOR COMFORT.** That's the opinion of smart suburbanites who wear a divided skirt for their daily activities. Cute Culottes are available in the finest pre-shrunk denim (navy or faded blue) or chambray (cadet blue, charcoal, or red). Roomy pockets. Sizes 10 to 22, \$5.95; Matching Jacket, \$5.95 ppd. Old Pueblo Traders, 622-ELC-So. Country Club, Tucson, Ariz.

*Merchandise shown on these pages can be ordered direct from the companies listed. Enclose a check or money order.*



**DOZEN PERSONALIZED GOLF BALLS** in smart, reusable case. Distinctively yours or as gifts for golfing friends and business associates. Top quality, liquid center golf balls made by one of America's leading manufacturers with golfer's name expertly imprinted on both sides of each ball. Please print name carefully. Only \$9.95 doz. Ppd. **POWER SALES CO.,** Box 113-D, Willow Grove, Pa.

**"Small-Fry"  
MINX  
DRESS-UP  
STOLE**

As elegant as mom's real mink, dressing up will be twice as much fun with this exquisite "MINX" stole. Perfectly scaled for "Little Women" aged 3-8, it feels and looks like the REAL THING. This wonderful gift will make you a "Fairy Godmother" to your daughter, niece, grandchild. The "MINX" stole is fully lined and even has slings for the arms to go through. In magnificent silver tony, it's every little lady's choice for formal engagements.

**\$2.98 ppd., Sorry No C.O.D.**  
**SPIRER'S, Dept. E-5**  
303 Fifth Ave. New York 16, N. Y.

# FAMILY SHOPPER

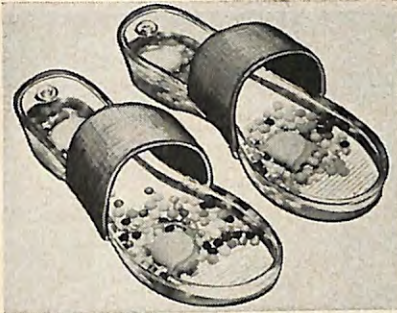

**SEA SANDALS.** Walking on water is no trick for the child wearing these colorful Sandals. "Aquariums" actually contain vividly colored sealife and tiny plastic fish that move as youngster walks. Sandals are leak-proof, unbreakable. Small (2-5 yrs.); medium (6-8); large (9-12). \$2.98 per pair ppd. Spencer Gifts, 341 Spencer Bldg., Atlantic City, N.J.

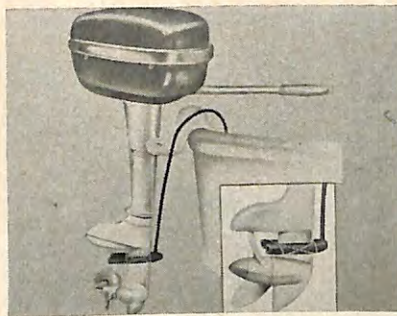

**VACU JET AUTOMATIC BOAT BAILER** sucks out 3 to 5 gallons of water a minute. Easy-to-install Bailer hooks on to any size outboard motor (except 3 h.p.). When motor starts, suction through top draws out water, cleans as it bails. Of plastic and vinyl tubing, it fits in tackle box. \$2.95 ppd. Scott-Mitchell House, 415 So. B'way., Dept. 5106, Yonkers, N.Y.

*Except for personalized items, there is a guaranteed refund on all merchandise returned in good condition within 7 days.*



**YOU'RE IN THE HALL OF FAME . . .** at least according to this whimsical banner. It proclaims you the World's Greatest-Golfer, Bowler, Husband, Wife or Lover—take your choice. Personalized Hall of Fame Banner is 12 x 18 in., of brilliant red felt with gold fringe. Specify title and name or initials. \$2.00 ppd., Medford Prod., Box 39, Dept. E, Bethpage, N.Y.



**CHRONOGRAPH WATCH** tells the time, measures distance and the speed of moving objects. It's also a stop-watch—all for only \$8.95. Precision-made with rugged, shock-resistant case, radium hands and numerals, sweep hand. One-year guarantee (excl. parts). Instructions and band included for \$8.95 ppd. Cryder Sales Corporation, Box 79-CC, Whitestone 57, N.Y.

## TEST SMOKE this NEW Cigar AT OUR RISK

SMOKE **25** ON THE HOUSE IN THIS SPECIAL INTRODUCTORY OFFER



Now — a new way of life for cigar smokers! Here's a completely new, modern cigar, a long slender MAVERICK shape, that's so mild even cigarette smokers will enjoy it. And, man, does it taste good! That's because it's a special blend with sun ripened Golden Isle leaf that's completely new in character, — so light, smooth and modern in taste.

This new Wally Frank MAVERICK promises to completely revolutionize the cigar business. We plan to bring out these MAVERICKS to compete with long slim cigars selling for luxury prices. But before we spend big money in advertising, we want your opinion as a cross check on our own tremendous enthusiasm. We'll rush you a full box of 50 Humidor-fresh MAVERICKS. Send us nothing for the cigars we've written them off for the test . . . . Just send \$1.00 to help cover postage, expense cigar tax and handling on this non-profit transaction. When they arrive, test smoke 25 on the house and tell us what you think of them. Then if you're not delighted return the balance for your \$1.00 back in full. Sorry only 1 box to a customer.

**WALLY FRANK Ltd.** Dept. A119  
132 Church St., New York 7, N. Y.

Send me a box of 50 MAVERICKS described above — I enclose \$1.00. I'll test smoke 25 and give you my honest opinion of them, and if I'm not delighted I'll return the balance for my dollar back. (in U.S.A. only.)

Please Print Name and Address Below

ACTUAL SIZE



**CONNIE MACK, Jr.,**  
son of the late beloved owner of the Philadelphia Athletics, says:

"Each FLORIDA community offers some of the features for which FLORIDA is famous, but—

### "CAPE CORAL HAS EVERYTHING!"

"The minute I saw Cape Coral, I knew that it was for me. I liked the careful planning, the location, the integrity of the developers. I bought my homesite and stayed on to join the management of Cape Coral as Associate Director."

- CAPE CORAL challenges comparison!
- CAPE CORAL invites inspection!

CAPE CORAL, on Florida's beautiful Gulf Coast, is offered and sold on merit alone for as little as \$20 down and \$20 per month!

See for yourself why Cape Coral is already the choice of over 6,000 families!

Send for and read the exciting "CAPE CORAL STORY" It's yours for the asking—**ABSOLUTELY FREE** Send No Money, Please



### CHAMBER OF COMMERCE MEMBER

Lee County and Ft. Myers • Dade County • Florida State

- Gulf Guaranty Land & Title Co., Dept. F12
- 1771 N. Tamiami Trail, Fort Myers, Florida
- Please rush my FREE copy of "The Cape Coral Story" in full color.
- Name.....
- Address.....
- City..... Zone..... State.....



## SPRINKLE UP TO 1500 Sq. Ft., \$1

New turbine-action Sprinkler spins a fine mist of water up to 1,500 square feet! Attaches to any hose. Set up singly, or in series... it's the world's lowest-priced sprinkler system. Versatile—can be moved where needed. Rugged, moulded-nylon design... can't clog, rust or get out of order! Guaranteed the most effective sprinkler you've ever used or money back! Only \$1, postage paid... three for \$2.79. Order WHIRL-A-JETS from Sunset House, 2841 Sunset Building, Beverly Hills, California.



## The Buff-alo-ha "HOLLYWOOD" MADE ENTIRELY BY HAND . . .

For ladies and men, natural color water buffalo leather imported from India. With comfortable cushion crepe rubber wedge and sole, they're the perfect year-round choice for men and women. Hand shaped to fit the arch.

Men's Sizes ..... 6-12 \$8.65 ppd.  
Women's Version ..... 4-10  
Money Back Guarantee. Brochure Available.  
311 6th Ave., Dept. EK-59  
New York 15, N. Y.  
**Bloom's**  
"Down in the Village" over 80 yrs.

## FlexPort PET DOOR



"I don't see how we ever got along without FlexPort before. We are more than pleased... we think FlexPort is terrific."

Puli Breeder,  
Connecticut

"The device is the greatest peace-of-mind restorer my wife and I have seen in a dog's age."

Editor,  
New York

## Keeps Out Flies, Wind, Rain

Dogs and cats are easily trained to use FlexPort. Ends scratched doors and whining. Gives you and pet complete freedom. Soft plastic triangles close gently and tightly. Easily installed in homes, kennels, garages, dog houses. Small, medium and large sizes available. Prices start at \$16.50. Do not send order. Write for free folder.



TUREN, Inc., Dept. L-5  
Beaver Park Danvers, Mass.

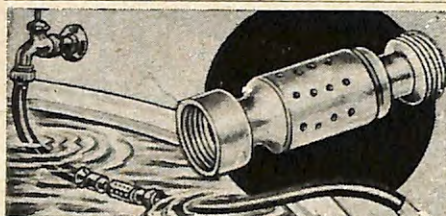

## PUMP WATER DRY—SAVE MONEY

### SUCT-DRI

Without electricity or moving parts this suction drainer pumps 330 gallons of water per hour from flooded cellars, pools, trenches, washing machine, etc. Just attach with a garden hose to any screw-type faucet, attach another section of hose to the discharge end, turn on the water and it goes to work. Mail your order today.

Only \$2.75

postpaid

MEDFORD PRODUCTS, Dept. 115, Box 39, Bethpage, N.Y.

## BLESSED RELIEF FROM VARICOSE VEINS

with Custom Made-to-Measure  
LASTONET ELASTIC HOSE

Made to your own personal measurements and rushed to you within 24 hours of receipt of order. Personally fitted 2-way stretch rubber-and-dacron fabric gives wonderful relief not possible with ordinary elastic hose. No binding, no wrinkling, lasts for months. Washes like nylon, dries in an hour. Open fabric for comfort, coolness. Every stocking guaranteed in writing. For MEN and WOMEN. Write NOW for FREE details mailed in plain package. No obligation!

SUFFOLK LABORATORIES, INC., Dept. A  
200 WILSON ST., PORT JEFFERSON STATION, N.Y.

FROM THIS



TO THIS



## OIL PORTRAIT KIT

Now you can preserve the image of yourself or loved ones in a genuine oil painting. No experience necessary! Send only \$9.95 and a photographic portrait, sharp, clear snapshot, or color slide (any size, black and white or color), to receive a "portrait-kit" which includes: a 14" x 20" canvas diagrammed to paint the portrait by numbered blanks; all oil paints; two fine brushes; full instructions and your unharmed photo. Please do not send picture frame.

Our new paint-by-numbers process (pat. pend.) results in a professional style portrait WITHOUT the usual patchwork appearance. A wonderful hobby. Prompt delivery.

Send only \$9.95 to

PORTRAIT CRAFT 620 Avalon Blvd.  
Wilmington 2, Calif.

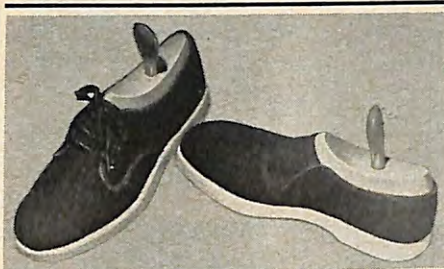

**CASUALS**— comfortable, airy, smart, for everyday or sports. Cool, washable fabric uppers. Cushioned-arch and insole. Thick rubber non-slip soles. Slip-on or oxford styles. Men's sizes 6½ to 13, Boy's 1 to 6, BLUE or BROWN. Women's, oxford style only, 4 to 9, BLUE or RED. Give shoe size, color and style.

A real money saving value! Order a pair for everyone in the family. Guaranteed Satisfaction. **\$2.99** Plus 50¢ Postage

PACIFIC CASUALS, P.O. Box 315, Bremerton, Washington



## "Silvered" COCKTAIL PICKS

Give your next party an elegant air with these gracious silver-plated hors d'oeuvres picks. All are rhodium luster-finished, and will never tarnish. Beautifully gift boxed, a set of six is a happy choice for a bride or special friend.

Set of 6, \$2.98 ppd., Sorry No C.O.D.

SYDMAR SALES CO., Dept. E-5

149 Canal Street New York City 2, N. Y.



## CLOGGED SEWER REMEMBER THE COSTLY PLUMBING BILL—

CHICAGO — May 1st. Just introduced is a Free Booklet on a New Discovery which enables the Home Owner, Housewife, Janitor, or Factory Maintenance to clean any Clogged Sewer Drain.

Yet anyone can operate this new Plumbers Flushing Gun which releases air pressure on a solid shaft of water cleaning the most stubborn stoppages up to 200 feet. TOILETS, SINKS, URINALS, BATHTUBS, FLOOR DRAINS, and HOUSE-TO-STREET SEWERS clogged with grease, Rags, Sand, Roots, and paper melt away instantly when struck by the Hammer-like blow of this new unit.

There is no need to remove wall or pipe, or Grease Trap. A special attachment allows water to flow from the faucet through the Gun while air is released on the pipe. Vents or stacks are no obstacle, as force tends to strike wherever the water lays. But now, what is this Plumbers Flushing Gun worth in COSTLY PLUMBING BILLS SAVED? Tear this Ad out, beside it for FREE BOOKLET. Obey that urge. No agent will call. A postcard will do. (Chicago Phone Eldorado 5-1702) MILLER SEWER ROD CO., DEPT. EL-5, 4640 N. Central Ave., Chicago 30, Illinois.

"Cleans Instantly"



## Stop Dog and Cat Damage—\$1

DOG WICKS are the perfect solution for repelling pets. One sniff and away they'll run! Hang this chemical Wick on shrub or branch and rest easy for the whole season. Rain won't wash away repellent scent. Safe, harmless to animals. Use inside or out—protects lawns, garbage pails, flowers, furniture. Trains your pets and neighbor's dogs. Guaranteed to do the job or your money back! Pack of 20 for \$1, postage paid. Order DOG WICKS direct by mail from Sunset House, 2841 Sunset Building, Beverly Hills, California.



## ELKS



**SIREN'S WAIL** clears the way for busy bicyclists. Powered by flashlight batteries, it sounds loud and clear. Gleaming chrome unit has push button, bracket and screws, attaches easily to handlebars of bicycles, motor-scooters, motorcycles, midget autos. \$3.98 ppd. (not including batteries). Miller's, 60 W. 33rd St., Dept. E, New York 1, N.Y.

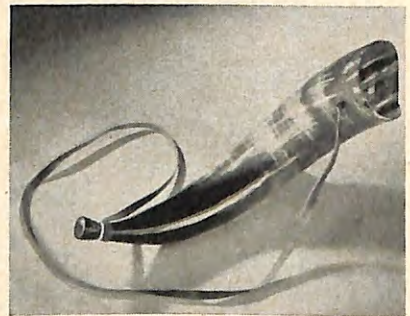

## SOUND THE HAPPY HUNTING HORN.

Genuine old-time bugle-type hunting horn is crafted from select steer horns, hand-polished, and comes equipped with rawhide shoulder thong. This imported beauty—of a type rarely seen today—measures 18 inches along the curve. Only \$3.95 ppd. Arms and Weapons, 49-A East 41st Street, New York 17, New York.



**MEET THE ORIGINAL BARHOUNDS.** Each of these 6 porcelain doggie drinkers is a typical barhound type, their comical characters unerringly portrayed by the artist. Colorful hand-painted figures are 5½ in. high and a gold label identifies each type. Wonderful for bar or rumpus room. Set of 6, \$3.95 ppd. Dresden Art, 230 S. Franklin St., Dept. EM, Chicago 6, Ill.

# FAMILY SHOPPER

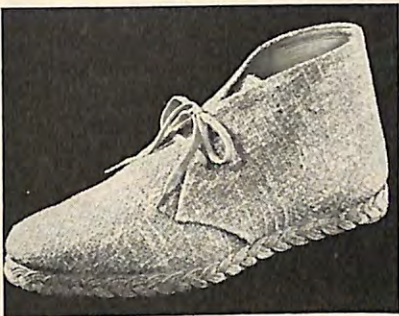

**HOPSACK CHUKKA BOOT.** Sporty in looks and light on the foot, these Italian shoes are wonderfully comfortable for boating, driving, hiking or just relaxing. They're made of fine wheat color Hopsack material with flexible soles of durable rope and rubber mixture. For men in sizes 6 to 12. \$7.95 plus 45¢ post. Fellman, Ltd., 49 W. 43 St., Dept. E, New York 36, N.Y.

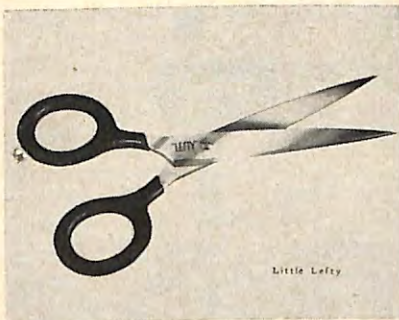

**SCISSORS FOR SOUTHPAWS.** The blades and handles on these Left-handed Scissors are completely reversed for comfortable handling by southpaws. 7-in. scissors are forged steel, hardened and tempered, with a lifetime guarantee against dullness. \$3.95. In 5-in. size for children, \$1.00. Add 25¢ for post. Magic Mold, 1140 B'way., Dept. E, New York, N.Y.

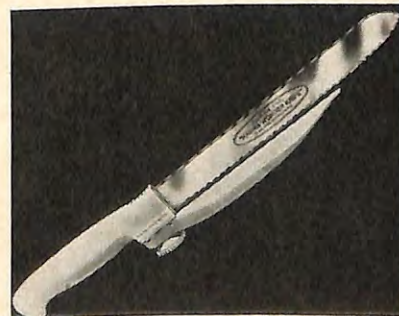

**MAGNA WONDER KNIFE** slices thick or thin, exactly to your taste. Fine quality Swiss stainless steel knife has "built-in" precision control, adjusts to slice, carve, shred, and chop food from 1/16 to 1/2 in. thick. Serrated edge needs no sharpening; handle is shatterproof plastic. \$4.95 ppd. Terry Elliott Co., 135 E. 44th St., Dept. W-6, New York 17, N.Y.

## MAILBOX MARKER

fits any mailbox—install in a minute

Style M  
**\$1.95**  
Postpaid

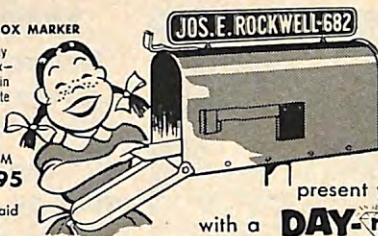

Style NM  
Name & Number  
MAILBOX MARKER . . . Postpaid  
**\$3.95**

present your name attractively with a **DAY-N-NIGHT** Marker

Guide your friends—beautify your home **SATISFACTION GUARANTEED**  
Perfect for gifts—any wording you want **OR MONEY BACK**

You get all these features on every DAY-n-NIGHT Marker!

- Letters shine bright at night
- Easy to read DAY-n-NIGHT
- 2-sided; raised letters on both sides
- Rustproof—lifetime aluminum throughout
- Permanent embossed lettering—raised in solid plates
- Baked enamel finish—black background—white reflector letters
- Attractive size—nameplates 2 1/2" x 18", number plates 2 1/2" x 7".
- Any wording you want, up to 17 letters and numbers on nameplates, up to 6 on number plates. Same on both sides.

Now COLOR! Choice of Antique Copper, Colonial Red, Pine Green only 50¢ per marker extra

**Speed ENGINEERING COMPANY**  
212 Spear Bldg., Colorado Springs, Colo.

MAKE \$5 AN HOUR FULL OR PART TIME! Take orders for DAY-n-NIGHT Markers—make up to \$5 an hour for your family, club, church, etc. Write today for FREE MONEY-MAKER KIT—start making more money right away!

WE SHIP WITHIN 48 HOURS—PLEASE PRINT CLEARLY  
C.O.D. if desired



Name & Number  
BRACKET MARKER  
Style NB **\$4.95** Postpaid

Two-Line  
BRACKET MARKER  
Style OB **\$5.95** Postpaid

BRACKET MARKER  
Style B **\$2.95** Postpaid

## WHEN YOU SHOP BY MAIL

These easy-to-follow suggestions make for smoother mail order buying:

- Always send check or money order—not cash—with your orders.
- Be sure to copy the name and address of the supplier correctly.
- If zone number is given, please include it.
- PRINT your own name and address legibly including street and number, city, zone and state.
- Keep the advertisement or jot down the name and address of the supplier for your records.
- Our advertisers are conscientious, reliable mail order firms, selling under a guarantee to refund the purchase price of any merchandise (not personalized) returned within 7 days.
- Nevertheless, a problem may sometimes arise. If it does, be sure to write us at once. Remember, your ELKS FAMILY SHOPPER takes a personal interest in seeing you have satisfaction from your mail order purchases through ELKS.

## GUARANTEED—GROWS EVEN WHERE OTHER GRASSES FAIL!

### READ THESE FACTS BEFORE YOU ORDER YOUR ZOYSIA GRASS



**ONLY \$5.75**

Order of Amazoy contains enough Zoysia Grass to grow endless supply of transplants and FULLY COVER MANY LAWNS WITH LIFETIME TURF IN 2 SEASONS. In the long run, Amazoy is the lowest cost, most beautiful lawn grass ever planted. Beautiful deep green in color. Like Kentucky Bluegrass in texture. Order Now.

**YOU CAN'T LOSE!**

### IMMEDIATE DELIVERY



CHOKES OUT CRABGRASS, SUMMER WEEDS!

Plant AMAZOY Pre-Cut Plugs In Existing Lawn, New Ground or Nursery Area.

1. NO SEEDS TO PLANT OR FAIL. NO WASTE. NO SOD TO CUT. Comes in fresh, green plugs of living grass that assure rapid, sure growth.
2. Just set pre-cut plugs into holes in ground, like a cork in a bottle. (Plant 1 foot apart, checkerboard style. Easy planting instructions with each order.)
3. Each soil-enriched plug takes root, spreads to cover planted area with thick, beautiful turf.
4. Amazing root system grows so deep (2-3 feet down) your lawn finds and retains its own supply of underground water. No more ugly brown or bare spots in your lawn due to heat & drought—EVER!

ENDLESS SUPPLY OF PLUG TRANSPLANTS

Amazoy plugs spread and cover planted area solidly. You can take 20-25 new plugs per square foot twice a year from established grass for transplanting. Plugged area soon grows over . . . transplant all summer long if desired! An endless supply.



FREE! Exclusive STEP-ON PLUGGER

Full size, saves bending, time & work whether planting or transplanting. Designed to cut away competing growth while it digs hole for plugs, assures faster, surer growth. Order at \$4.95, or free with large orders.

Dept. 236, ZOYSIA FARM NURSERIES  
602 N. Howard St., Baltimore 1, Md.  
333 N. Michigan St., Chicago 1, Ill.  
80 Boylston St., Boston 16, Mass.

## NO RISK OFFER

Meyer Z-52 Zoysia Grass Was Perfected By U.S. Govt. Approved by U.S. Golf Assn.

- \* Perennial. Beautiful Amazoy Lawn Never Needs Re-seeding. Perfect for Problem Areas.
- \* Won't Burn Brown, Won't Winter Kill.
- \* Resists Fungus, Insects, Diseases and Blight.
- \* Banishes Bald Spots. Ends Summer-Long Campaigns Against Weeds With Costly Weed-Killers.
- \* Grows Lower—Mow It As Little As 6 Times A Year.
- \* Planted in U.S. Air Bases, Post Office Grounds, Golf Courses, Famous Estates, etc.

Thousands of delighted Amazoy owners prove that AMAZOY'S thick, rich, established turf stays green through blistering heat & drought . . . actually laughs at water bans . . . yet won't winter kill (has survived temperatures 30° below 0). Your established AMAZOY lawn is so thick, so deep-rooted, it resists blight, disease, insects . . . it chokes out weeds and crabgrass all summer long. A true perennial, it goes off color after killing frosts, regains fresh green color every Spring! Even in midsummer droughts when other lawns burn out . . . yours will be lush, green, lovely—the pride of your neighborhood!

**GUARANTEED TO GROW IN ANY SOIL—EVEN SANDY, SALTY BEACH AREAS!**

AMAZOY grows in good soil, bad soil—YOU POSITIVELY CAN'T LOSE, because every plug is guaranteed to grow and spread, or replaced FREE at our expense! Resists erosion. Planted in Racking Turf Courses; takes pounding horses hooves and springs back into beautiful green carpet of grass. So forget ordinary grass that burns out, turns to hay, costs money every year. Start your AMAZOY lawn now!

**SAVES YOU MONEY** Amazoy ends yearly seed expense and reseeding . . . cuts water bills and fertilizer costs . . . cuts weed-killer costs. (Cuts time, expense and work mowing. It's the lawn that NEVER NEEDS REPLACEMENT!)

Plug In Zoysia Praised By: NEWSWEEK, LOOK, FLOWER GROWER, POP GARDENING, ORGANIC GARDENING, HARBERS, PETS, MECHANICS, UNIVERSE, GROWING, Arthur Godfrey on TV, etc. No other grass ever won such praise!

100 Large Pre-Cut Plugs	<b>5.75</b>	300 Large Pre-Cut Plugs & Plugger	<b>15.95</b>
100 Large Pre-Cut Plugs & Plugger	<b>8.95</b>	1000 Large Pre-Cut Plugs & Plugger	<b>34.95</b>

ORDER NOW—CLIP COUPON. Once Again Demand May Exceed Supply. All Orders Shipped In Order Received.

Dept. 236, ZOYSIA FARM NURSERIES, 602 N. Howard St., Baltimore 1, Md.  
333 N. Michigan St., Chicago 1, Ill.  
80 Boylston St., Boston 16, Mass.  
Please ship the following order of Amazoy Meyer Z-52

100 PLUGS \$5.75  100 PLUGS & PLUGGER \$8.95  300 PLUGS & PLUGGER \$15.95

How orders are shipped. If you live east of the Miss. River, add 75¢ per 100 plugs. If you live west of Miss. River, add \$2.25 per 100 plugs, and we pay all shipping. Otherwise we ship your order Express Charges Collect.

1000 PLUGS & PLUGGER (F.O. Baito.) \$34.95  
I enclose . . . check . . . money order . . . cash  
Name . . . . .  
Address . . . . .  
City . . . . . Zone . . . . . State . . . . .

## MORE FUN OUTDOORS!



Outdoor entertaining is more gracious with the . . .



### HIDE-A-WAY Garbage Receiver

Life around the grill or patio becomes more attractive, more fun when unsightly garbage cans are hidden, yet handy. Easily installed by any home owner. Complete with galvanized shell and removable can, self closing lid that seals contents from air. Sanitary, odorless, fly, vermin proof. \$15.95 freight pd. \$20.95 west of Rockies. Check or M.O. please, No C.O.D. Ohio residents add 3% Sales Tax.

### PARTY HOUSE

BOX 66, TERRACE PARK, OHIO

## THE adjustable ALL-IN-ONE GOLF CLUB

Does everything a set will do . . . So easy and thrifty!

Scientifically designed head adjusts to each position so its all you need. TRY IT — We guarantee you'll enjoy playing with only 1 club or your money back. Spec. 36" short; 37" Med.; 38" long.

International Golf Products HINSDALE 67, ILLINOIS



JUST DIAL YOUR SHOT PUTTER-DRIVER 3-5-7-9 IRONS

Postpaid \$24.95

### For Those Who Do Not Want GREY HAIR

Now Top Secret's amazing scientific formula gives a natural looking color to faded or grey hair . . . makes you look years younger! Top Secret does not streak or injure hair, does not wash out.

"I noticed results after just a few applications," says Jan Garber, Idol of the Airlines. "Top Secret is easy to use—doesn't stain hands or scalp. Top Secret is the only hair dressing I use."

Time-proven Top Secret has been used by famous personalities for years.

Send \$5 (Fed. Tax incl.) for 6 oz. plastic container, convenient for traveling, too. Ppd. No COD's, please. Money back if not delighted with results of first bottle! Albin of California, Room 54-91, 3100 Vanowen St., Burbank, Calif.



## FABULOUS, NEW 5-Ft. Long Balloons

Twist Into A Thousand Shapes! GIRAFFES—DACHSHUNDS—Pets of All Kinds

Made of Live Latex **200 for \$1** Add 25c Postage and Handling

Delight Kiddies—Grown-Ups, Too!

Almost 5 feet long when inflated. Balloons this size usually sell up to 25c each. Send only \$1 now. Plus 25c postage and handling for 200 in a variety of gay colors! Supply limited at this low price, so order several sets NOW for GUARANTEED PROMPT DELIVERY. MONEY BACK GUARANTEE. FREE Complete Instructions.

MURRAY HILL HOUSE

Dept. B-725-A, P.O. Box 251, Bethpage, L. I., N. Y.

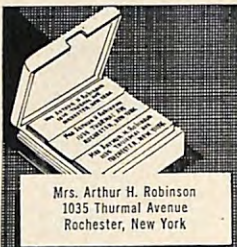

## 1000 Name & Address Labels \$1

ANY 3 DIFFERENT ORDERS \$2 ppd. SAVE! SPECIAL OFFER!

Mrs. Arthur H. Robinson  
1035 Thurmal Avenue  
Rochester, New York

Sensational bargain! Your name and address handsomely printed on 1000 finest quality gummed labels. Padded. Packed with FREE, useful Plastic GIFT BOX. Use them on stationery, checks, books, cards, records, etc. Beautifully printed on finest quality gummed paper—1000 only \$1. SPECIAL—SAVE MONEY! ANY 3 DIFFERENT ORDERS \$2. Makes an ideal gift. If you don't agree this is the buy of the year, we'll refund your money in full. HANDY LABELS, 506 Jasperson Bldg., Culver City 1, California.



### SLIP IT ON YOUR "SPECS" . . . \$1

Wear VISORETTE on prescription or sun glasses, indoors or out. Stops glare from sun, sky, windows, lights. Adjustable to any angle. So light! So comfortable! Slips on & off in a jiffy! Guaranteed to fit and satisfy. Many thousands of users! Choices: Transparent green or opaque black. Send \$1.00. VISORETTE, 2925 E. California, Pasadena 32, Calif.

## Save \$4 to \$6 a Pair on NYLON ELASTIC HOSE



ONLY \$1.98

EACH \$3.95 a pair

Health Aid Co., Dept. No. 7959  
P. O. Box 1035 Cincinnati 1, Ohio

Regularly sell at twice this price. Price slash possible due to tiny irregularities. These are beautiful, seamless Nylon Elastic stockings with open toe, closed heel, of Lastex with two-way stretch. Complete satisfaction or return within 7 days for full refund. Get quick relief from tired, aching legs, varicose veins. Send calf measure and measurement from bend in back of knee to bottom of heel. Order TODAY.

## FREE to Cigar Smokers

Get our FREE Catalog and see our low, low prices for well-known, nationally advertised cigars.

You get factory seconds with bands removed, that give 100% satisfaction of perfect cigars selling for twice the price. All sizes and shapes. 26c size only 11c — and ten centers as low as 5c. Get our FREE offer.

### Save Up To 50% On Your Favorite Cigar

Smoke 5 on us to prove they satisfy. Puff for puff, they give the superb smoking pleasure of your favorite brand. Drop card with name & address. Get offer & Catalog by return mail.

SILVER ROD SALES CO.  
14 JOURNAL SQ. • Dept. 205 • JERSEY CITY 6, N. J.



### GLASSES REPAIR KIT \$1.00 ppd.

Have you ever lost the screws from your glasses or had them work loose? Now you can be ready for these emergencies with this glasses repair kit. Invaluable when traveling, hunting—at office or home. Consists of a professional optical screwdriver and an assortment of standard frame screws and nuts. Instructions included. Ideal for working on watches or small mechanisms. Calif. resid. add 4c state tax. COLUMBIA CO., 404 Security Bldg., 234 E. Colorado St., Pasadena 23, Calif.



## ELKS FAMILY SHOPPER



HUNTER'S PRIZE . . . Solingen steel Trophy Knife made by a famous German manufacturer. Superior quality knife has a heavyweight 5½-in. tapered blade of fine Solingen steel with razor-sharp edge, a thick, genuine stag horn handle, brass guard, and polished cordovan leather belt sheath. \$9.75 ppd. Norm Thompson, 1311 N.W. 21st., Dept. E, Portland 9, Ore.



ROD-O-MATIC cleans clogged drains easily and swiftly. Place over drain opening, turn the crank to release up to 10 ft. of rust-proof spring steel that snakes through pipe, around bends, and clears out stoppage. Turn crank backward and steel returns to its drum-like housing. Over-all length, 7½ in. \$3.95 ppd. Elron, 352 W. Ontario St., Chicago 10, Ill.



SPOT REDUCER . . . a relaxing, soothing massager that eases tense muscles and takes off unwanted pounds. It's easy to apply this electrically-powered hand unit to hard-to-reach areas. Just plug it in, grasp handle and massage. U.L. approved. \$9.98 ppd. Deluxe Model with scalp massager, \$12.98 ppd. Body Massager Co., 403 Market St., Dept. B214, Newark 2, N.J.

## In the Dog House

(Continued from page 28)

ancestors of the mixed breed of today. What the mongrel's enthusiasts don't see are the thousands of dogs of bygone times that perished because they weren't able mentally or physically.

It's a truth in the minds of many that the color of a dog's coat is a clue to his disposition. A red coat means a vicious dog, a spotted coat a genius at hunting. It would be equally truthful to say that anyone wearing blue feels that way. Have you your blues on today?

Then there's that old saying "You can't teach an old dog new tricks"—you've probably heard it. If so, file and forget it. Experienced trainers will tell you that many dogs well on in years have not only been taught new tricks or commands but some that have never been schooled before have learned to obey. The older dog may be a bit more difficult to teach than the youngster but in nearly every instance the older pooch has been trained to tricks or commands. One of the oldest I know about was a Dalmatian aged ten who was successfully trained in official obedience work. For the average dog the life span is 12 to 14 years, so the ten-year-old pupil was not exactly a puppy.

It wouldn't do to leave this one out—the preposterous idea that the man or woman who doesn't like dogs is not to be trusted or the dog that shies away from certain people instinctively knows those folks are bad actors. Many fine people just don't happen to be enthusiastic about Fido and there's nothing they or anyone else can do about it. Then there are dogs that just don't happen to care for certain people. Nothing

mysterious about either case. One of the more reckless steeplechase jockeys I ever knew, a wild Irishman from Boston, had a horror fixation about cats. Yet I saw him successfully pilot horses that other experienced jocks couldn't be bribed to ride.

Testing for breeding—somewhere you may have met or may meet someone who will assure you that a black mouth is an infallible sign of a dog's pure breeding. Don't believe it. Many dogs have mouths spotted with black and an ancestry equally spotted. The only dog with a mouth required to be black is the chowchow and this is a matter of specification in the dog's standard as established by the Chowchow Club.

This isn't a superstition but a misconception, although firmly held by many people and for no good reason. It concerns the fantastic idea that certain breeds are vicious and certain others are smarter than their cousins. Neither is true. Dogs, as I've written many times in these pages, differ as do people. There are ugly tempered specimens among them but no uniformly vicious breeds. Some of the larger dogs of the working division are more reserved and less inclined to fraternize with strange people than other breeds. But these are not vicious any more than the quiet, shy, reserved person would be. Most dogs of working type, collie, Doberman pinscher, boxer, great Dane, for example, are dogs originating in sparsely settled farm areas where strangers were few and as such were viewed with suspicion. The descendants of these dogs still retain that quality of reserve, which has nothing to do with viciousness. They just don't welcome overhandling by people they don't know too well. As for one breed being smarter than another, that is not so either. In all breeds there are fatheads and intelligent dogs. Naturally the breeds that have had the closest association with man, usually the smaller dogs kept as house pets, have developed better understanding of man's requirements and have handed down to successive generations that knowledge or perception of human conduct. Some dogs of some of the breeds erroneously believed to be smarter than most dogs will at times absolutely refuse to learn a command and will unexpectedly do the most foolish things. But then, to repeat, dogs in many ways are like people. Each is an individual.

### Ed Faust Solves Dog Problems

*If you have a question or problem in connection with your dog, ask Ed Faust about it. He will be glad to answer any question that is not of a medical nature. Write to Ed Faust, THE ELKS MAGAZINE, 386 Fourth Avenue, New York 16, N. Y.*

How to Know  
and Care for

Your  
DOG



This is the title of the dog book by Ed Faust, author of "In the Dog House" which appears regularly in The Elks Magazine. The 48 pages of this book are packed with information that will help you care for your dog. Here you'll find answers to the problems of feeding, training, common sickness—told concisely and in an easy-to-read manner. Many illustrations and descriptions of popular breeds. Thousands of copies have been sold to pleased readers. Endorsed by leading dog authorities.

**PRICE ONLY 35c POSTPAID**

Please do not send stamps

**IT'S THE ANSWER**

to your dog problems—so

**SEND FOR IT TODAY**

Please print name and address

**THE ELKS MAGAZINE  
386 FOURTH AVENUE  
NEW YORK 16, N. Y.**

### The Girl Scouts Thank Mr. Wisely

All Elks will greatly appreciate the recognition of their assistance to youth, contained in the following letter from Mrs. Malcolm S. Edgar, First Vice President of the Girl Scouts, received by Grand Exalted Ruler Horace R. Wisely:

"On behalf of the Girl Scouts of the United States of America, I am happy to send congratulations on the excellent Youth Day Proclamation issued by the Benevolent and Protective Order of Elks (in the March issue). At a time when so much criticism is leveled at youth, it is most heartening to have attention called to the fine qualities and achievements of our young people.

"We also appreciate the birthday salute to the Girl Scouts which appears in the March issue of THE ELKS MAGAZINE. Thank you very much for the interest and support of the Benevolent and Protective Order of Elks."

## HUNDREDS OF IDEAS

### for BRONZE PLAQUES

FREE illustrated brochure shows hundreds of original ideas for reasonably priced solid bronze plaques—nameplates, awards, testimonials, honor rolls, memorials, markers.

Write for FREE BROCHURE A For trophy, medal, cup ideas ask for Brochure B.

INTERNATIONAL BRONZE TABLET CO., INC.

Dept. 40—150 West 22 St., New York 11

## ENRICH YOUR LIFE WHILE YOU SLEEP

Free—the amazing story of how you can enjoy a more abundant life—increase your self-confidence health vitality—improve your finances, willpower and develop a new magnetic personality through Nocturnal Education (Sleep Learning) as used by our Government, Universities and many of the World's most successful individuals. Send for revealing data - - - FREE.

CAMBRIDGE INSTITUTE  
Dept. 6 1157 So. Robertson Blvd.  
Los Angeles 35, Calif.

## Elks Insignia

ON SPORTS SHIRTS  
10 Indelible Decals \$1.00  
in Lodge Colors  
Press on with hot iron  
SEND ONE DOLLAR TO  
EMBLEMS 606 Main St. Nashville 6, Tenn.



## The History of The Order of Elks

... no finer gift for an Elk.

You couldn't choose a more appropriate gift for an Elk than a copy of the authoritative HISTORY OF THE ORDER OF ELKS.

This handsomely bound, well-written book contains 432 pages, 145 illustrations, and a wealth of facts about the Order of Elks not generally known to many members. Some of the interesting highlights include: the founding of the Order; who started it; how the ritual originated; its outstanding personages, and the Elks accomplishments over the years.

As a gift, or for your home, lodge or community library, THE HISTORY OF THE ORDER OF ELKS will be welcomed and enjoyed. Send for your copy today. Price—\$4.17 post paid. For New York City orders add 12 cents sales tax. Send remittance to: BOOK, THE ELKS MAGAZINE, 386 Fourth Avenue, New York 16, N.Y.

## For Elks Who Travel

(Continued from page 15)

lakes dot the Province all the way up to Hudson Bay and James Bay, which border it on the north. Here are a couple of typical resorts: Killarney Lodge, on the Lake of the Two Rivers in Algonquin Park, is 188 miles from Toronto and 180 miles from Ottawa. The lodge is a collection of log bungalows on a peninsula jutting into the lake, and all of them have hot water and showers. There is a sandy beach, fishing for trout, bass and perch, hiking trails in the Park, and day-long canoe trips for fishermen and photographers. The weekly rate comes to \$60 to \$75 per person if two people occupy a double room. Youngsters are charged three quarters of the adult fare.

Less woody and more resorty is Cleverlands House on Lake Rousseau, in the Muskoka region of Canada. It can take about 200 people, offers tennis, water skiing, trail riding, and golf on a six-hole course. There is another full sized links nearby. From Toronto: 139 miles. Rates are anywhere from \$9 to \$17 a day, depending upon the number of people occupying the same room, the season, and the location of the quarters.

Manitoba, Saskatchewan and Alberta are a broad stretch of prairie land full of lakes, canoes, Indians, boat trips and fishing lodges. Western Airlines and Northwest Airlines have fishing tours to Arctic Lodge at Reindeer Lake in Northern Saskatchewan. Western's offering comes to about \$500 from Minneapolis and St. Paul, including meals, lodging, guides' fees, boats and the plane from the Twin Cities. Another trip in the prairies is the ride on the S.S. Keenora up Lake Winnipeg to Norway House. It costs \$75 for the four-day trip from Selkirk, Manitoba, with stopover privileges available at Norway House.

The Prairies grow into the Rockies in Alberta, perhaps Canada's most awesome scenery. Banff, the Canadian Pacific's resort, is a great stone palace looking down the alley of a valley with great white-topped peaks rising behind. Nearby is Chateau Lake Louise with its glacier sliding into the lake, its bordering poppies, and its glass-enclosed heated swimming pool. There are 400 rooms with bath at Chateau Lake Louise, 600 rooms with bath at Banff Springs. The CPR offers two-day tours of the Rockies, beginning at \$54 per person, two in a room, to seven-day tours at \$191.25 for one person in a superior accommodation. The Canadian National has a lovely resort at Jasper in the Rockies, with upholstered log lodge living and a green-carpeted golf course famous for its layout and for its bears that provide a mobile obstacle.

On the west coast there is the water-land of Vancouver and Vancouver Is-

land and the lovely city of Victoria, where roses bloom all year around. The inland cruises are like Norwegian fjord trips. Union Steamships offers independent cruises from Vancouver along the British Columbia Coast, and any number of cruises are available that go beyond Canada into the edge of Alaska and along the Trail of '98.

Finally, anybody seeking to get absolutely away from it all can bed down in the most de luxe fishing resort ever conceived. It is called Charctic Lodge and is located at Ward's Inlet of Frobisher Bay, Baffin Island, in the Northwest Territories of Canada. Frobisher Bay sees civilization quite often, what with TWA and SAS stopping by on over-the-pole flights. The tab at this place is a piddling \$1,500 a week, including air travel from Montreal. For that they ought to put the fish on the hook, and mount it afterward.



BASEBALL season is with us again and this year all 16 major league teams will use United Airlines Mainliners during the 1959 season. Charter trips began April 3rd, when Cleveland and San Francisco shared a DC-7 Mainliner from Phoenix to Salt Lake City for an exhibition game.

Those of our readers who want to recover from the long winter might try island hopping. You stop a day, a week—at Bermuda, Puerto Rico, Virgin Isles, St. Kitts, Jamaica and Nassau—all this at the low cost of \$228.70 (Tourist Class) round trip from New York. Get in touch with BOAC (British Overseas Airways Corporation), Dept. BWT-8, 530 Fifth Avenue, New York 36, N. Y.

Here is another wonderful way to forget your troubles: take an Alcoa Steamship cruise on one of their newest cargo-passenger ships out of New Orleans. This will be your home for 16 wonderful days. Everything from air-conditioning to radar has been installed to make your cruise comfortable, convenient and safe. The ship will carry about 60 passengers,



## Elks National Home News

Once again the beauty of the Elks National Home in Bedford, Va., has made news in many places.

**GERMAN MAGAZINE.** Brother Herman Hundhausen, who came to this country from Germany 50 years ago, has been a resident of the Home for eight years, and has written a number of articles about the beauty of his residence. One of his articles appeared last year in a West German newspaper, and another appeared more recently in the German-language American newspaper, the *Neu York Staats-Zeitung und Herold*. His latest journalistic appearance is in *Krupp Mitteilungen*, a magazine published by Germany's Krupp Industries. In a letter to the Editors, Mr. Hundhausen relates some of his experiences in Germany and in America (he once had a business connection with Krupp) and he sends greetings to his old friends in Essen from his present home at Bedford. With his letter there appeared this photograph, showing Mr. Hundhausen strolling before the Home.

**NEW ROCHELLE BULLETIN.** In a recent issue of *Pierrot*, the bulletin of New Rochelle, N. Y., Lodge, Brothers Thomas Kiernan, Alfred Ford and Adolph Sprechter give an account of a visit they made to the Home. In describing their tour with official guide C. R. Russ, they term the beautiful buildings and grounds a true monument to Elkdom. The visitors were also greatly impressed by the organ music which



is played each evening by Mrs. Brady, wife of Superintendent Thomas J. Brady. Of Mr. Brady himself the article says: "His ability, ingenuity and perception make him an outstanding man in this important position."

**BEDFORD PAPERS.** The Elks National Home also receives frequent praise from the newspapers of neighboring Bedford, Va. For example, the *Bedford Democrat* recently reported that a group of civic leaders who visited the Home were profoundly impressed by the improvements lately made there (reported in the February issue of *THE ELKS MAGAZINE*). The paper printed this comment by Mayor E. L. Carlyle, speaking for the group: "This has been a very fine experience and our community is wonderfully fortunate in having this Home here."



for a rare adventure  
in travel elegance...fly  
**BRANIFF**



your finest way to  
**CHICAGO**  
for the  
**Elks**  
**Convention**  
**July 5-9**  
fast, frequent flights

Enjoy the luxury of the finest  
in flying, food and service . . .  
fly Braniff!

Call your Travel Agent or  
local Braniff ticket office.

Braniff serves more major cities  
in the U.S.A. and South America  
than any other airline.

**BRANIFF**  
*International*  
**AIRWAYS**

and the good times you have on board will equal anything you have ever had or seen on the more luxurious trans-Atlantic steamers. First stop is Ciudad Trujillo, then Caracas, the wonder city of Venezuela. After a couple more stops in this country, you reach Trinidad, then to either Willemstad, Curacao or Kingston, Jamaica. For more details on this type of cruise, write the Alcoa Steamship Company, 17 Battery Place, New York 4, N. Y.

Greyhound Lines is coming up with some mighty fine tours of the interesting places in our own country. These tours range from 6 to 31 days and cover everywhere from Maine to Mexico. If you are interested, get in touch with your local Greyhound agent.

To our readers in the central and western part of the United States who are planning to attend the Elks Convention in Chicago in July 1959: the Santa Fe Railway has just about the best service possible between Chicago, Texas and California. The road's fabulous streamliners are equipped with chair cars and Pullmans of the most luxurious type. Some of these trains feature the Big Dome Lounge, where you can see not

only on each side of you, but the mountains looming above. The Santa Fe also has Family Plan rates and Rent-A-Car service at your destination. For more information, contact the Atchison, Topeka and Santa Fe Railway System, 238 S. Michigan Avenue, Chicago 4.

Planning to visit the Maritime Provinces this summer? If so, don't overlook Prince Edward Island—Canada's Garden Province. P.E.I. is noted for some of the finest beaches in the world. While American-plan accommodations are somewhat limited, the Gregor Hotel is recommended. Free golf and ponies for the youngsters are available. For booklet and rates, write to Jack Cameron, owner, Gregor Hotel, Brackley Beach, Prince Edward Island, Canada.

According to the American Automobile Association, the largest apple-growing section of the U. S. is the Shenandoah Valley, including Virginia, West Virginia and part of Maryland. It's the place to drive to in apple blossom time, for its beauty is unsurpassed. If, however, you won't find it convenient, the second largest apple-growing area is the southwest section of Michigan and the adjacent part of Indiana.

## When Big Business Moves to Town

(Continued from page 13)

### Our Need For Negatives

In an effort to improve the quality of our photographic reproductions in the fraternal news pages, we adopted a new policy last year with regard to our requirements for the fraternal photographs we publish.

It has been determined that very often a better print may be secured when we are able to have one made to our own specifications. We are therefore requesting that, whenever possible, the negatives be sent along with the glossy prints of all photographs submitted for publication in the Magazine. We shall be more than pleased to return both negatives and prints after they have served this purpose.

Your cooperation in supplying us with negatives of lodge photos will help us to maintain a high standard of quality in your Magazine and will give a much more satisfactory presentation for your lodge as well as for its activities.

We have had an impressive response to our request for negatives, but it has not been 100 per cent. While we do realize that certain local photographers are reluctant to lend us their negatives, we nevertheless urge you to continue to try to obtain them. We repeat that all negatives will be returned promptly after we have made our prints.

If you are unable to secure a negative, please let us know when you submit the print. You will be informed immediately as to whether or not it will be possible for us to reproduce your print.

The cooperation we are receiving from the majority of lodges is deeply appreciated. We are publishing this reminder for the benefit of those who may have overlooked previous notices in this connection. We are sure all of you will cooperate in this endeavor to better the appearance of your Magazine.

Little League baseball diamond. Philadelphia Electric issues a manual on trees for city beautification. A General Motors plant lends fuel to a hospital during a coal strike. A pipe line company permits adjacent residents to farm its right of way and demonstrates soil control.

Some efforts are purely mechanical: the distribution of films to club and church groups. Some involve heroism. When in 1955 hurricanes Connie and Diane dumped eleven inches of rain in the popular Pocono Mountains vacation area of Pennsylvania, thousands of threatened children in summer camps were isolated from frantic parents. For 72 hours there was no public power. More than 7,500 telephone stations were wiped out. Telephone employees met the emergency—one woman struggled 14 hours to get to her post. They built a new bridge, laid miles of cable and gradually restored vital communications.

In practicing the gentle art of being a good neighbor, big business has been plagued by the sometimes conflicting desire of making a significant contribution and at the same time seeking appropriate recognition. Appropriate recognition has often been translated to mean lots of publicity. The natural urge for kudos and fanfare—temperately described as a “don't-hide-your-light-under-a-bushel-basket” philosophy—is often most readily satisfied by giving away relatively large sums of money. Money is news, and for some reason giving it away is close behind stealing it or losing it in making headlines. Moreover, cash donations are presumed to result from honest toil, a nationally revered symbol. They are also a complete package. They need involve no further effort; no tiresome and sometimes disillusioning investigation into how fruitfully the money was spent. It is no handicap, either, that cash finds eager acceptance.

Without in the least disparaging the importance of untrammelled bundles of money—appeals for cash charitable donations are today the No. 1 good neighbor headache—a few companies came to realize that often cash alone is not enough. The gift of a hospital wing involves serious fiscal problems of maintenance. Donating a \$500,000 playground park to the city cuts off needed tax revenues. Even endowing a university lecture course raises questions of need, of its place in the curriculum and of future rising costs.

Thoughtful corporate leaders observed that the warm glow of community appreciation following monetary benefactions sometimes quickly fades. They also noted that one large public gift almost invariably attracted numerous if more modest requests from philan-

thropic enterprises which were poised to undertake virtually unlimited good works and needed only cash to set them off. Judging from the appeals, human misery was expansible and could accommodate itself to whatever growth—and profits—American industry could achieve. Obviously the time had come for enlightened management to take a hard look at corporate charity.

Those companies which undertook critical self-analysis discovered first of all that quick publicity was not the payoff. Unsupported, a few clippings attesting to generosity had but a transient effect on community neighbors. As often as not the reaction was, “So what? They've got plenty.”

Another discovery was that philanthropy is a specialty which calls for expert administration. A company successful in making soap or automobiles or refrigerators doesn't necessarily know about slum rehabilitation, public libraries, hospitals or the problems of instructing 70 fourth-graders with one classroom and one and a half teachers.

They confirmed an old and sometimes disputed axiom: money isn't everything. Executive capabilities, energy, imagination, specialized knowledge, as in cost controls, for example, might be worth far more to a charity than even a basketful of cash. To be good neighbors, big neighbors are learning the importance of giving of themselves before they can give wisely of their money.

Among the real leaders in the new neighborliness movement there has been a further change in concept. Considered corporate giving is now rarely dictated by an individual. Less and less are decisions rendered in the home office. More and more initiative is taken by the community plant manager. Within reasonable costs he can be as good a neighbor for his company as he is for himself.

An executive of a company planning to spend more than \$1,000,000 on civic improvements described the new approach. “We do not regard this as a gift to the city,” he told community leaders, “but rather as a proper price for the benefits which will accrue to the company, its employees and its stockholders from the project.”

Such thinking led Ford Motor Company to make a separate gift to the affected college for every scholarship it awarded youngsters of Ford employees. Thus, too, Detroit Steel Corporation makes an annual four-year scholarship award in labor relations to deserving high school graduates, neighbors of its plant in Portsmouth, Ohio. Not long ago such an award would have been unthinkable.

A few industrial leaders were among the first to recognize the growing crisis

in education. They saw that the problem would become as broad as the country itself; that enormous population shifts would often compound the pressure of the bountiful baby crop and that resistance to increased taxes would frustrate efforts to provide adequate facilities. Then some of them were suddenly confronted with the great post-war scientist-engineer drought.

It was serious because basic business progress begins in a laboratory. The laboratory technician may be a chemist, an engineer, a market analyst, a sales manager or a business systems coordinator; he is a specialist by training and experience. Students simply weren't getting essential academic background. The future of industry depended on a growing supply of trained and competent people. It was obviously in jeopardy. Business leaders quickly realized that perhaps the most enduring evidence of good neighborliness was to encourage improvement in education.

There were many ideas for meeting the problem. In California, for example, the huge Bank of America, an old hand at good neighborliness, has established achievement awards which in the past eleven years have been distributed to 23,000 winning high school students. Of these, 2,000 have won cash awards totaling \$335,000. Virtually every high school in the state participates.

To encourage students with scientific interests, some 500 Junior Engineering Technical Society (JETS) clubs, with more than 15,000 members in nearly every state, are being aided by industry, among other sponsors, to undertake challenging projects. At Republic Aviation, on Long Island, youngsters are working on an electronic automobile that automatically will follow a light beam, and on a Big Ear, a device for picking up normal conversation from 100 feet away.

At Midland, Michigan, Dow Corning Corp. is operating exchange days with schools in nine surrounding counties. While 75 teachers spend a day at the plant an equal number of qualified company personnel takes over their classes and shows the students how classroom learning is used in industry. These exchange days are found in many parts of the country. Business-Industry-Education days, in which education takes a quick but rewarding look at industry and vice versa, have now been featured in hundreds of communities.

In Monroe, Louisiana, Olin Mathieson Chemical Corp. gave the school board \$10,000 to try out an outstanding scientific teacher on the faculty and reports great success. Hughes Aircraft sends out teams to make classroom scientific demonstrations and lectures, as does the Convair Division of General Dynamics. General Motors has long sponsored traveling science shows which have sparked the interest of hundreds of thousands of young adults.

Programs such as these are making a deep scratch on the surface of the fundamental problem but only on the surface. They arouse the interest of students, of course, but this can boomerang. If there is no available outlet for that interest; if there is no satisfying follow-up provided by school or industry, it may fade away and become much more difficult to revive. Nevertheless, there are hidden values not readily apparent. One is a subtle effect on both industrialists and educators. Working together, they gain mutual respect. Suspicions that businessmen are materialists or that educators are impractical dreamers are quickly allayed.

Most important, the outward success of these programs stimulates further effort. One midwestern company several years ago decided with some misgivings to open its plant to employee families and other neighbors. Some 18,000 guests showed up and happily devoured 39,372 hot dogs, 24,576 ice cream bars, and 44,420 soft drinks, while discovering how the factory worked. The president was so pleased with this response that his new good neighborliness soon included such diverse activities as all-cost nursing scholarships and aid to the city in annexing nearby unincorporated communities to meet serious tax problems.

Most stimulating are the programs

aimed at deep penetration of the education problem. One of these, a model of its kind, recognizes that not every company can develop its own plan that is both unique and useful. This is the Merit Scholarship Program begun with a Ford Foundation grant in 1955 and now subscribed to by some 90 companies. It provides four-year stipends to students, supplemented by grants to the colleges they attend. This year more than 500,000 students will compete. It is noteworthy that the donor company receives virtually no publicity for its contribution.

While Merit Scholarships spread good neighborliness over the whole country, General Foods Corporation is starting a promising program in plant communities which enables local high schools to select qualified teachers for special summer training. Towns like Caribou, Maine; Waseca, Minnesota; and San Leandro, California, are now getting upgraded teachers in such subjects as education, history and state politics and highly important remedial reading.

Few big neighbors have been more acutely aware of the need for grass roots training to meet future demands for scientific personnel than General Electric, which strives to be a good neighbor in 140 communities. GE today employs 34,000 graduates of 790

**Father's Day Special! Since 1926! The Halvorfold**

Loose-leaf Pass Case, Billfold, Card Case. Note exclusive features. Read Special Offer below

Name, address and any Fraternal Emblem in 23K Gold FREE

8-pass capacity replaceable

\$6.00 Black or brown Morocco

\$8.50 Smooth black or brown Calfskin

Now with or without ELK emblem outside front

**"Made to Order" for ELKS**

**Free Examination!**  
**Send No Money—Pay No C.O.D.**

Means exactly what it says. No strings. Mail coupon. Halvorfold comes by return mail. Examine it carefully. Slip in passes and cards. See how handy it is. Show it to your friends and note their admiration. Compare it with other cases at more money. I trust ELKS and all the Mrs. ELKS, who buy annually, as suture-shooters. And I am so sure the Halvorfold is just what you need that I am making you the fairest offer I know how. Send coupon NOW. Avoid last minute rush!

**FREE** in 23K Gold, Name, Address and any Emblem. Would ordinarily cost \$2.50 extra. Ideal Gift with friend's name and any fraternal emblem.

**HALVORFOLD, P.C.M.—700 E. Union Street  
Jacksonville, Florida—Dept. 101**

Send HALVORFOLD as per instructions below. If I decide to keep them, I will send check at once. If not, I will return merchandise in three (3) days. (HALVORFOLD comes regularly for 8 passes. For 12-pass add .25c. 16-pass .50c, etc. Please check squares at right.)

**PLEASE CHECK HERE:**

Black Calfskin \$8.50  Brown Calif. \$8.50  
 Black Morocco \$6.00  Brown Mor. \$6.00  
 Gold Filled Snap & Corners \$1.50 extra  
 8-pass  12-pass  16-pass  
 ELKS Emblem Outside  Yes  No

Name:..... 23K Gold Inside Emblem:.....  
Please Print

Address:.....  
5% off to save bookkeeping, if you prefer to send cash with order. Money back if not satisfied.



# GUARD YOUR FAMILY



# FIGHT CANCER WITH A CHECKUP AND A CHECK



Send your gift to "CANCER"  
in care of your local post office  
**AMERICAN CANCER SOCIETY**



colleges and is confident that this figure will increase steadily and substantially.

GE decided to establish summer fellowships for high school teachers and in 1945 brought together the first group of 50 chemistry, math and physics instructors for an intensive six weeks' course at Union College in Schenectady. This year seven universities are participating and the company contribution has risen to \$350,000. Intensive classroom work is dramatized by extensive use of regular factory operations as a practical laboratory.

The effect on participating teachers—and through them on their pupils—is immediate and rewarding. By survey, some 95 per cent have reacted favorably, ranging in degree from appreciation to outright enthusiasm. Two-thirds of them subsequently received special honors, salary advances or promotions. Overwhelmingly, they agree the courses make school work more interesting to the students. A mournful but indicative complaint was expressed by one participating school: "The program was so valuable our faculty member was hired by a larger school system for more money."

Occasionally, education presents an unusual opportunity for good neighborliness. When Michigan State University decided to open an entirely new campus in Oakland County, near Detroit, James C. Zeder, Vice President of Chrysler Corp., saw his chance. As President of Chrysler's Institute of Engineering, he had been named chairman of the curriculum committee for the brand new college. Serving with him were a diverse group of laymen, including the head of an advertising agency, a circuit judge, a newspaper publisher, a labor leader, and an Air Force Major General.

Zeder and his committee decided to invite to Detroit leaders in four major phases of education. Each group would conduct a panel aimed at answers to such questions as, "What would I teach in a brand new college with no traditions, inhibitions or strictures?"

Picking up his telephone last summer, Zeder called, among others, C. Richard Soderberg, Engineering Dean, Massachusetts Institute of Technology; Henry T. Heald, President, Ford Foundation; Theodore V. Houser, Chairman, Sears-Roebuck; Milton S. Eisenhower, President, Johns Hopkins; Henry R. Luce, Time, Inc., and Sarah G. Blanding, President, Vassar College. He asked them to participate in Saturday discussions devoted to engineering, business administration, liberal arts and teaching and education.

When final decisions on the curriculum are made Zeder and his committee are confident that MSU (Oakland) will offer its community courses enriched by some of the country's most advanced thinkers.

But the program which may prove to

combine most effectively the unlimited education opportunities with good neighborliness was sparked by American Iron and Steel Institute and Armco Steel Corp. It was designed to use the community itself as a facility for teaching. That is why Middletown, Ohio, where it started in 1952, has been called "The Town That Became a Classroom."

To find out what teachers wanted, Steel Institute's public relations counsel asked questions and got answers from some 5,000 educators. Overwhelmingly they said appropriate industry materials could be useful. What they wanted ranged from industrial field trips to work on school problems with civic groups. (Least desired was the long-outmoded essay contest.) The study, perhaps the most comprehensive ever made, pointed time and time again to education needs which could be filled within the school's own community. As a pilot project, the Steel Institute and Armco decided to aid a summer community-resources workshop in Armco's Butler County, in cooperation with Miami University in nearby Oxford.

For six weeks, 29 teachers searched the surrounding community for facilities to make education more meaningful. The result: a handbook of local resources and completely new teaching skills and techniques. As one of them summed it up: "The workshop awakened me to the vast resources available in my hometown." Said another: "Industry worked out materials *with* teachers instead of *for* them."

The enthusiasm of participants for the first workshop quickly infected other business and industry in Butler County. It was something everybody should get behind, civic leaders said. They did. Middletown's Industrial Council decided to sponsor the effort. The small grocer and druggist became as much a part of the workshop as the union leader, the school principal and the industrialist. Now a Junior Workshop is started and elementary school students spend summer days swarming around Middletown, descending on mills and factories, the newspaper plant and the city hall, asking questions and learning what makes the community tick.

Because the idea "causes the pupils to catch fire and the teachers to glow" and because it is inexpensive—about \$5,000 for a six-weeks workshop for 30 teachers—it was bound to spread. It has. This year Community Workshops will be conducted in 22 areas, including Canada and Mexico. They will give new dimensions to the classrooms of tens of thousands of students who will find their once dull textbooks, as one pedagogue said, "charged with life and meaning."

This is what happened when a big neighbor wanted to be a good neighbor in the cities where it made steel.

A most comprehensive, promising,

and quite different good neighbor effort is being pioneered by General Electric in developing a better business climate for industry. This sounds vague and abstruse. It is as practical as a toothbrush. It is simply the creation of a community atmosphere in which well managed business can profitably produce fairly priced useful products for its customers and productive jobs at commensurate wages for its employees.

A better business climate attracts and holds business and industry. This means community prosperity. Money can't buy it. It doesn't just happen. It has to be planned, worked for and earned. Without it communities invite slow, crumbling decay. They can't

grow. They won't stand still. All they can do is fall back.

Many stagnant areas over the country are falling back. After a century a carpet factory moves away. An air conditioning plant and an elevator factory pull out. A file company shifts its manufacturing to other plants and reluctantly yanks the economic props out from under 620 employees and their families. The taxes these companies once paid now must be met by others. The stores which served their employees must find new customers or face hardship or bankruptcy.

Why do companies move? Usually because they can't stay where they are and stay in business.

All this is important, says GE, if only because industrial jobs mean dollars. A U. S. Chamber of Commerce study shows 100 industrial jobs in a community can create:

- 74 additional jobs
- 112 more households
- 4 more retail stores
- \$590,000 more annual personal income
- \$360,000 more annual retail sales

Take away 100 jobs and the picture is reversed.

What makes for a better business climate? The elements are simple:

1. Citizen understanding of and participation in civic and business problems.
2. Honest and efficient government through alert and informed voters.
3. Good transportation, hotel, shopping, bank, and hospital facilities.
4. A social and cultural atmosphere which will attract professional employees.
5. Qualified people developed in a sound education system to fill employment needs.

There are others such as a fair press, non-discriminatory taxes, constructive union leadership. In other words, favorable climate is created.

The problems of business climate are being thrashed out in Los Angeles and in Louisville; in Mattoon, Illinois, and Glens Falls, New York. General Telephone, with 48,000 employees, is sparking a do-it-yourself better climate effort among its member companies. In its plants Ford Motor Company is adding a better local business climate to the community responsibilities of managers.

There are many ways in which big neighbors can be good neighbors. And they will become even better neighbors in the future. But they will be the best neighbors in those communities where business—all business—is encouraged to develop, to expand, to provide more and better jobs for more and more people. These are the places where the community is a good neighbor, too. • •

## THE ELKS MAGAZINE Small Business Articles

This article by Dickson Hartwell is another in a series that THE ELKS MAGAZINE is publishing in the interest of the very substantial percentage of members of the B.P.O.E. that, surveys prove, are engaged in small business. Previous articles in the series included:

**SMALL BUSINESS' STAKE IN BIG BUSINESS**, by EMLYN LLOYD (January 1958). How a giant corporation works with 12,553 suppliers.

**GOING AHEAD WITH EMPLOYEES**, by ROBERT FROMAN (March 1958). Basic employee relations in small business.

**WHAT THE SBA CAN DO FOR YOU**, by WENDELL B. BARNES, Director, Small Business Adm. (May 1958).

**ENGINEERS IN THE NEW ERA OF SCIENCE**, by DR. EDWIN S. BURDELL, President of the Cooper Union (February 1959).

**PROGRAM FOR PROTECTION**, by EUGENE RACHLIS (March 1959). Types of company insurance for a small businessman to consider.

**GOVERNMENT REGULATIONS AND SMALL BUSINESS**, by DICKSON HARTWELL (April 1959).

Copies of any, or all, of the issues in which the previous small business articles appeared are available without charge. In ordering copies, please specify date of issue and enclose 5 cents in stamps for each issue requested. Orders should be sent to THE ELKS MAGAZINE, 386 Fourth Avenue, New York 16, N.Y. Because of limited supplies, please limit requests to one copy of any issue. Your comments and criticism or suggestions about this series of articles are welcome.

## CUSHIONED



Style  
K169  
Black  
Calf  
A to EE  
6 to 12  
\$14.95



# KNAPP

## Aerotred Shoes

Full line of Dress, Sport and Service Shoes for Men and Women  
Sizes 3 to 18 — Widths AAA to EEEE

Preferred choice of millions . . . for handsome styling . . . superb quality . . . Original Cushioned Comfort! Choose *your* Knapp Aerotreds from over 180 smart styles in Dress, Sport and Service Shoes for Men and Women. Enjoy Knapp's complete Factory-Fitting Service and substantial Factory-To-You Savings . . . No other shoes offer more — *at any price!*

### WRITE FOR FREE STYLE FOLDER

and name of your local Knapp Shoe Counselor.  
(Or check Yellow Pages of your phone book.)

**KNAPP BROS. SHOE MFG. CORP.**  
DEPT. 28C, Brockton, Mass.

Name .....  
Address .....  
City ..... State.....

A few choice territories open to experienced shoemen as Knapp Shoe Counselors. For full information write: Dept. 28CX, Knapp Bros. Shoe Mfg. Corp., Brockton, Mass.

## People 60 to 80

### APPLY FOR OLD LINE LEGAL RESERVE LIFE INSURANCE

If you are under 80, you can still apply for a \$1,000 life insurance policy to help take care of final expenses without burdening your family.

You handle the entire transaction by mail with OLD AMERICAN of KANSAS CITY. No obligation. No one will call on you!

Tear out this ad and mail it today with your name, address and year of birth to Old American Insurance Co., 1 West 9th, Dept. L555M, Kansas City, Missouri.

## Rod and Gun

(Continued from page 8)

Jules P. Cuenin, and many others whose names have slipped my memory.

I met Myron in San Francisco and we got to Monte Rio late in the afternoon. Bill Schaadt was painting a sign. He left bucket and brush hanging in mid-air, threw his waders over his shoulder, grabbed his rod, and we went fishing. I didn't catch anything that evening, which probably was just as well. Anticipation grows keener as the goal appears more difficult.

Despite the fact that I caught no shad, I learned quite a bit about fishing for them. To begin with, they are like steelhead in the respect that they don't lie just anywhere—or if they do, you can't catch them in some kinds of water.

They seem to prefer moderately deep and moderately swift water—not the deepest and not the fastest, but a good, strong flow from three to six feet deep is to their liking. They lie in the channel, near the bottom, like steelhead.

In fact, there is even a marked similarity in fishing for these two, totally different, anadromous fish, and all the shad anglers I met on the Russian River were using their steelhead tackle. This consisted of a fly rod capable of long casts, usually a powerful nine-footer, and a sinking line.

You cast across the channel, usually straight across or angling slightly upstream, and let the line sink as it drifts down. When it has passed you and begun to tighten, in the meantime sinking several feet, you begin to work your fly by jerking the line.

In this one respect, shad fishing is different. Steelhead are often caught on a fly that has no motion whatever except that imparted to it by the current; Shad never seem to hit unless the fly is darting erratically. Each angler had worked out his own system for giving his fly the required action. Bill Schaadt jerked his line steadily, using quick, sharp, four-inch pulls, one after the other. Howard George gave his line three sharp, short jerks followed by a slower, steady pull that took in about a foot of line. After each series of movements, of course, they both let the current pull out the line again.

The strike of a shad is—but wait! Bill, Myron and I went out to the river again next morning, to a place called Fyfe Creek. The sun was just warming the lovely California hills, and the mist was still rising from the water. I waded in until I could cast across the current, which was heavier toward the far shore.

I stripped out line and made a cast and jerked the line to start it sinking. It swung down, sinking as it went. I pulled the slack out, held the rod low and started jerking the line with my left hand. I had jerked it maybe 40 or 50 times—Bill Schaadt says you can tell a

shad fisherman as far as you can see him because his left hand jerks all the time, automatically—and the line was swinging rapidly toward my side of the current. When it reached the slack water there, of course, I would have to strip in and cast again.

Suddenly, it was jerked out of my fingers. It felt as though a colt had hit the end of it, running full speed the other way. I grabbed it and quickly raised the rod to strike, but that was probably unnecessary. The shad undoubtedly set the hook.

In seconds, all of the loose line trailing away downstream had hissed up from the water and shot out through the guides, throwing off a spray of droplets

he held briefly, rolled on the surface, and raced back down. He didn't take so much line this time. He was, no doubt, beginning to get tired. I knew he was getting tired because he had already resisted longer than any four- or five-pound fish has any right to.

Suddenly, he jumped. After all that, he jumped again! Spent fish don't jump. So we started over and eventually I forced him, still protesting, toward the beach. I wouldn't say I led him. Leading implies compliance on the part of whatever is being led. The shad, by this time so tired that he could no longer hold himself upright, still struggled. Even when I slid him out of the water, his tail beat a tattoo on the sand.

This fight was typical, with few exceptions, of every shad we hooked. One in twenty-five, maybe, or one in fifty, didn't have any more spunk than a dishrag. I think perhaps these occasional fish had completed spawning—which, of course, is their reason for entering fresh water—and were exhausted.

There was only one bad thing about shad fishing as I found it on the Russian River: you only need one fly. Or, to be more accurate, you only need one pattern of fly. You use up about fifteen per day because you have to fish deep and, as all steelhead and shad anglers know, rocks and logs on the bottom have a way of reaching up and attaching themselves firmly to any fly that passes near.

When you start out in the morning to fish for trout you never know whether they will prefer this fly or that one or maybe something else. This adds to the uncertainty. You always change flies with keen anticipation, hoping that the new pattern will be exactly what they want, and when you finally discover the right one you feel genuine satisfaction.

This is missing in shad fishing. You tie on *the* fly and start casting. If you don't get strikes it can mean only that the fish aren't there or else that they are present but aren't hitting at the moment. You can tie on a different fly if you want to, but you'll spend your time to better advantage if you lie down on the beach and go to sleep or else drive up- or downriver a few miles and try.

This standard fly, which Carl Ludemann is credited with originating, is tied on a No. 4 hook. First, a sparse red-hackle tail is attached, then the shank is wrapped with lead wire to give it weight. Oval silver tinsel is wrapped over the lead, which is held in place and tapered at the rear with tying thread. Next, two, and only two, turns of white hackle are taken at the front of the silver body. Finally, a small ball of red chenille is made behind the eye of the hook (see page 8).

While I was there, fully 95 per cent of the shad caught were hooked on this

### STATE ASSOCIATION CONVENTIONS

Ohio	Columbus	Apr. 30, May 1-2-3
Missouri	Kansas City	May 1-2-3
Mississippi	Jackson	May 2-3
Kansas	Wichita	May 8-9-10
Oklahoma	Ardmore	May 8-9-10
Arizona	Yuma	May 13-14-15-16
New York	New York	May 14-15-16
North Carolina	Greensboro	May 14-15-16
Wyoming	Thermopolis	May 14-15-16
Alabama	Tuscaloosa	May 14-15-16-17
Iowa	Davenport	May 15-16-17
Georgia	Brunswick	May 20-21-22-23
Florida	Pensacola	May 21-22-23
Indiana	Muncie	May 21-22-23-24
Illinois	Joliet	May 22-23-24
Michigan	Port Huron	May 22-23-24
Nebraska	Lincoln	May 22-23-24
New Hampshire	Claremont	May 22-23-24
Vermont	Springfield	May 22-23-24
Wisconsin	Superior	May 22-23-24
Arkansas	Hot Springs	May 23-24
Texas	San Antonio	June 3-4-5-6
Idaho	Caldwell	June 4-5-6
Kentucky	Henderson	June 4-5-6
Minnesota	Stillwater	June 4-5-6-7
Connecticut	Willimantic	June 5-6
Oregon	Klamath Falls	June 5-6-7
North Dakota	Grand Forks	June 7-8-9
Utah	Logan	June 11-12-13
South Carolina	Charleston	June 12-13
Washington	Olympia	June 18-19-20
New Jersey	Atlantic City	June 19-20
Massachusetts	Plymouth	June 19-20-21

that sparkled in the morning sun. My reel began to sing the sweetest song known to an angler.

The shad ripped off 50 feet of line, then threw itself into the air. It jumped again and again, twisting and shaking. It acted like a five-pound tarpon.

When it finally discovered that it wasn't too slick to stay in the water after all, it bored back into the current and hung there, its silvery, flat side no doubt turned to take full advantage of the sweeping current. I put the butt of the deeply bent rod against my belly and held. I held as hard as I thought prudent, and that is pretty hard with a steelhead rod and six-pound test tippet, while the line sang in the water and the shad hung tight.

Eventually, of course, he had to move. He worked his way back upstream, passed me, and continued into the riffle at the head of the pool, fighting both the rod and the river. There

one fly. Occasionally, somebody would try something else, usually a small buck-tail with silver body and some red and white or yellow showing, and occasionally one of these flies took a fish. There was never a time, however, when we couldn't hook as many or more on the Ludemann Shad Fly. And not once did we succeed in taking shad on another pattern when they refused the standard.

Strangely, fly fishing was far and away the best method to hook these Russian River shad. I say strangely because in the East, where I haven't fished for them, everybody seems to agree that lures are better. Even so redoubtable a fly fisherman as Joe Brooks reports in his book, *Salt Water Fly Fishing* (Putnam, \$3.50): "Shad will hit small buck-tails and spinner-bucktail combinations now and then. They hit the small, scantily tied Connecticut shad fly hard and often. But for consistent strikes, no other lure seems to have the same appeal for shad as does the 00 Huntington Drone, the Metalure, and Trix-Oreno. Shad definitely go for spoon-type lures."

One day on the Russian River near Healdsburg, Myron Gregory, Boots Rogers and I had caught shad until we were exhausted and we were lying on the bank, resting for another session, when a fellow stopped his car beside the road and walked down to talk to us. It developed that he was a tackle salesman. He had a spinning outfit and enough lures to decorate all the Christmas trees in Sonoma County. He wanted to catch a shad.

We told him where they were and sicked him on. He fished a dozen small, glittering lures through the water where the shad were lying and didn't get a touch. He fished deep and shallow, slow and fast, with jerks and without. Then Boots tied one of the Ludemann flies to the end of his line and attached a quarter-ounce weight two feet above so he could cast it. Still, not a single shad rewarded him.

By this time, we were beginning to wonder if they had moved away or quit striking. Myron, Boots and I picked up our rods, separated by fifty feet, and laid out casts. Almost within seconds, we all three had shad on.

When Boots and Myron beached theirs to remove the fly and turn them loose—I released mine at thirty yards—the salesman looked carefully at the lovely fish. Then he said, more or less to himself, "That's bad!"

Myron glanced up in surprise. "What's bad?" he asked.

"Why," said the salesman, glancing ruefully at his box of lures, "shad are bad. I've got to sell this stuff."

"It's a good thing," he added, as he gathered up gear and started toward his car, "the others are not so bad as shad." Then, looking back over his shoulder with a broad grin as he walked away, "I'll bet I have a fly rod along the next time I come by here!" ● ●



**Direct Prices & Discounts to Churches, Schools, Clubs, Lodges and All Organizations**

**COMPLETE CATALOG ON REQUEST**

#### MONROE TRUCKS



For handling and storing folding tables and chairs. The easy, modern way. Choice of models.



#### FOLDING CHAIRS

Steel built, sturdy, convenient.

#### PORTABLE PARTITIONS

Change your idle space into useful areas with these Partitions. Masonite panels in tubular steel frames with swivel action pedestals and casters or glides.



**THE Monroe COMPANY**  
90 Church St. Colfax, Iowa

## WIN AT POKER

You can start winning instead of losing after reading the first page. Simple, easy to follow rules on how to play winning poker. Send no money! 10-Day Free Trial! Only if you are satisfied do you send us \$2.50 (postage paid). Otherwise return book with no obligation. The sooner you send us your name, the sooner you start winning. Write today!

**INSTRUCTION BOOKS, INC.**  
Box 3457, Dept. 39, E. Chicago, Ind.

## TRY THE WALL STREET JOURNAL GET-AHEAD PLAN

**\$7 STARTS YOU**

You are living in a period of far-reaching changes. New inventions, new industries and new ways of doing business are creating opportunities for men who want to get ahead.

It will pay you to find out about these things. One place to find out is in the pages of *The Wall Street Journal*. You probably think *The Journal* is just for millionaires. That is WRONG. *The Journal* is a wonderful aid to salaried men making \$7,500 to \$25,000 a year. It is valuable to owners of small businesses. It can be of priceless benefit to ambitious young men who want to earn more money. Said one subscriber, "I read *The Journal* every morning and apply its lessons to my own business. I call this my 'get-ahead' plan."

To assure speedy delivery to you anywhere in the U.S., *The Journal* is printed daily in five cities—New York, Washington, Chicago, Dallas and San Francisco. It costs \$24 a year, but you can get a Trial Subscription for 3 months for \$7. Just tear out this ad and attach check for \$7 and mail. Or tell us to bill you. Address: *The Wall Street Journal*, 44 Broad St., New York 4, N. Y. EM-5

# CAN WE MAKE MONEY TOGETHER?

Do you have what it takes to start your own automotive wholesale business?

I want a practical, hard-headed man with the guts to succeed in his own business. Someone who doesn't kid himself about how easy it would be if he were the boss. This opportunity is only for a man who will work hard, devote his full time and be able to make an investment of about \$8,500 in a truck and stock.



**CHARLES E. BOWES**  
President

Still with me? Then here's the story: If you are the man I'm looking for, you will have a chance to become a franchised distributor, for the Bowes "Seal Fast" Corporation. In this business of your own, you'll meet the needs of service station operators for automotive parts and accessories—products they must have to stay open. You'll make money. Good money. And there's no

ceiling on your earnings. We'll make money too. So we're careful to pick the right man and give him all the training and help he needs toward building a solid, depression-proof business.

Is this what you're looking for? Then write today for our free booklet, "So You Want To Be Your Own Boss!" It has all the facts about this opportunity, and there's no obligation. Send your request to: Mr. Charles E. Bowes, President, The Bowes "Seal Fast" Corporation, 5902 E. 34th Street, Dept. 775, Indianapolis 18, Indiana.

Bowes Distributors throughout the country are part of a multi-million dollar operation. They represent a firm which in 40 years has grown to be one of the largest of its kind, with plants in London, England; Hamilton, Ontario; Riverside, California, and Indianapolis. Its credit rating is the highest (AAA-1) available.



# ELKS NATIONAL FOUNDATION

## "The Joy of Giving"



Giving a check for \$1,500 to Boston University President Harold C. Case in support of the seventh annual Institute on Cerebral Palsy is William H. Shaw, President of the Massachusetts Elks Assn. Left to right are: Past State Pres. Dr. William F. Maguire; Judge John E. Fenton, Committee on Judiciary; Mr. Shaw; Dr. Case; Elks National Foundation Chairman John F. Malley; Grand Trustee Edward A. Spry; and Prof. Arthur G. Miller, Director of the Institute.

## Massachusetts Elks Fight Cerebral Palsy

In support of the seventh annual Institute on Cerebral Palsy, a check for \$1,500 has been given by the Massachusetts State Elks Association to President Harold C. Case of Boston University, where a portion of the program will be held next June in cooperation with the Children's Medical Center of Boston. The check was presented to Dr. Case by William H. Shaw of Adams, Mass., President of the Massachusetts Elks Association.

Enrollment will be limited to 25 persons and is open to teachers and accredited therapists in the field. The Elks National Foundation, under the chairmanship of Past Grand Exalted Ruler John F. Malley, will grant scholarships to many of those attending the Institute who intend to use their training for treatment of the cerebral palsied.

The Institute will offer a series of lectures, demonstrations and clinical experiences on current information and techniques in the education of children with cerebral palsy, for a two-week period, June 8-19, according to Dr. Arthur G. Miller, Director of the Institute and a Professor of Education at Boston University's School of Education.

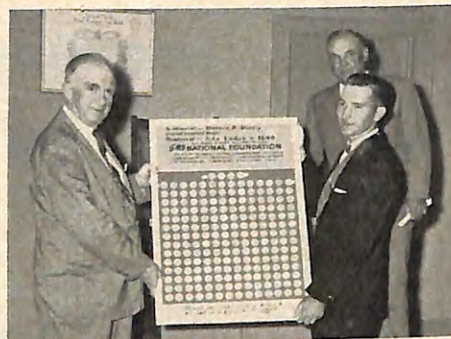

Past Grand Exalted Ruler Earl E. James, right background, looks on approvingly as E.R. Jim Wilcox of Ada, Okla., Lodge presents this board of \$100 in half-dollars to Floyd Hyer (left) Special Deputy for the Foundation. Coinboard represents payment on Ada Lodge's \$1,000 Permanent Benefactor's Certificate.



At a recent visit of District Deputy M. L. Ormsbee to Durango, Colo., Lodge, recess was taken at the lodge meeting to present checks of \$200 each to two handicapped students. The lodge sponsored two of the seven winners in Colorado, who received Handicapped Student Scholarships. From left to right: Merle Albright, Chairman, Handicapped Student Committee; H. Herbert Seigle, Secy. and Co-Chairman; District Deputy Ormsbee; E.R. Dallas C. Hiatt; students Martin H. Morrison and Billie Lee Hayes.

## Fastest Growing Sport

(Continued from page 11)

millions of boats, and millions of Americans gone plumb boat crazy.

\$2,085,000,000 were spent over the retail counter on pleasure boating last year. Petroleum companies poured 404,057,000 gallons of gasoline into pleasure boats during the year. The lumber industry supplied 171,000,000 square feet of sheet plywood to boat builders during the 12-month period. 47,000,000 pounds of aluminum and 36,900,000 pounds of fiberglass went into boats in 1958, and 10,435,000 gallons of paint and varnish were sold to boat owners and builders. Outboard motor manufacturers sold 545,000 new motors in 1958, bringing the total number of outboards in the country to over 5,525,000.

The figures are quoted from a joint report on boating by the National Association of Engine and Boat Manufacturers and the Outboard Boating Club of America.

One wonders who these 37 million people are, with 2 billion dollars to spend on boating. A like number never before existed in the history of the world. A few, of course, are wealthy yachtsmen who could afford to pay a million dollars or so for revival of America's Cup competition last year in expensive 12-Meter racing sloops. Many are professional and managerial people of comfortable means who own 2,000,000 boats. But the great majority of boatmen whose money keeps builders busy turning out new models are citizens with modest incomes, classes of people who a generation ago wouldn't have dreamed of boat ownership.

According to a factual survey by the statistical research firm of Sindlinger, Inc., for *Popular Boating* magazine, most boatmen today are "clerical, sales and kindred personnel, craftsmen, foremen, vehicle and machine operators, laborers, service employees, domestics, students and housewives." (8,839,000 non-working housewives were reported to be actively interested in boating. That's more than the present number of boats in existence in the United States. If the "power of a woman," which we are continually reminded "never to underestimate" means anything—then the boom in boating is likely to continue.)

Individual annual incomes of \$5,000 to \$10,000 provided most of the \$2,085,000,000 in last year's boating till. And the typical outboard-powered runabout owned by the typical boatman today is 14 feet long, trailered once a week 15 to 30 miles to water, used for fishing, skiing and family cruising, costs from \$500 to \$1,500 (including motor), and is better cared for than either the owner's house or car.

Why is this? What is this yen for getting afloat? There are millions and millions of amateur sailors; and the cities



can't hold them, the highways can't transport them far enough from everyday realities, the plains can't compete with the call of the water world.

There's something for everyone to do in a boat. Dad can fish or mess around with his tool-kit or practice navigation. Sis and Junior can steer and water ski. Mom may not give a hoot about tying sailor knots, but she can watch over her entire brood aboard the family flagship where even cooking and dishwashing are adventures Dad and the kids enjoy.

Of course, there are other reasons for the boom: the "40-hour week" and increased leisure time; credit buying in a period of material prosperity; need for outdoor activity for the whole family.

Increased numbers of facilities and lakes from dam construction have also provided people with new means to get afloat. At this very moment a lake is building behind the giant Oahe Dam in North Dakota which will be longer than Lake Ontario and deeper than Lake Erie. It will water another 2,500-mile shoreline of reason for boating.

Fact is, the mere presence of water is reason enough for most people to get into boating. The problem is not why, but *how*. And the prospective boat owner might well begin by asking about his credit at a local bank, where 15 per cent of the present boating population bought new craft and 30 per cent of the hopefuls like himself plan to finance the purchase of theirs.

From this point in approach to the problem of buying a boat, a man goes on to look over the market—perhaps going to one of the 35 or 40 boat shows held each year, dropping in on local dealers, writing to manufacturers and other authorities for information and advice. Probably he starts to read a boating magazine. They are the best means of communication in the field, and nearly all bring out a special "Boat Show" issue with listings of thousands of items from diesel yachts to paint pots.

What does the boat shopper find? He finds that he is confronted with the picture of approximately 250 boat builders in the country turning out over 2,000 different stock models on assembly line basis. There are wood planked boats and sheet plywood boats and molded plywood boats and fiber-glass boats, aluminum and steel and rubber and

canvas boats. Boats galore!—each type with its special advantages.

Prices range from \$200 to \$2,000 for a new 14-foot runabout, plus another \$225 for a 5½-horsepower motor, \$340 for a 10-horsepower motor, \$625 for a 35-horsepower motor, any one of which might be suitable for a 14-foot boat, depending on its type.

Second hand prices, if one is in the market for a used boat, depend more on the condition of the hull and equipment than age. But generally a boat in reasonably good shape will bring 30 per cent to 50 per cent of its new-boat price tag. *Blue Book* evaluation of used outboard motors averages 50 per cent of price when new for a one-year-old motor; 40 per cent for a 2-year-old motor; 30 per cent for a 3- or 4-year-old motor, and so on.

If it is a cruising boat the shopper wants, one with more space and living accommodations aboard, a new 18- to 22-foot outboard cruiser will cost between \$1,500 and \$3,000, fully equipped without power. Another \$750 will buy one new 50-horsepower motor. About \$1,000 is required to fit the boat with a 60-horsepower motor and accessories. A little more will permit twin 35's.

A trailer for the rig costs from \$150 to \$400, depending on the size of the boat and weight of the rig. Mooring fees at a club or marina vary from next to nothing to \$10 per foot length of boat for the season (including water, electricity, refuse disposal, a watchman and other facilities).

Inboard-powered cruisers are somewhat more expensive than their outboard counterparts, but the 4-cycle engines use less gas and have other advantages, not the least of which is accessibility for repairs in a seaway. Outboards, on the other hand, by virtue of being hung over the stern, are easily raised if the boat goes aground in shallow water.

Sailboats, specialty craft, and the hundreds of odds-and-ends of equipment useful in a boat, are matters the prospective boatman should discuss with local dealers, his boating neighbors and friends. A look at the boats in prevalence on the waters he intends to frequent will give him an idea of his needs. Most new boat owners burden themselves with junk they later throw away. It would be more sensible to spend the money on Coast Guard approved fire extinguishers, a reliable compass, anchor, life jackets, and an insurance policy.

When considering the worthiness of such expenditures on a hobby or sport, the new boat owner is inclined to seek justification of his purchases. This is not as difficult as it would seem. How much money has been saved that would otherwise be spent in hotel bills and restaurant checks, vacationing with the whole family? How much more important is it to spend weekends together doing

## A FAMOUS PHYSICIAN WRITES ABOUT HEARING LOSS

What causes a hearing loss? What are the corrective measures that one can take? Answers to these questions, and many others, are found in Zenith's authoritative booklet, "Hearing Loss and the Family Doctor," written by a nationally prominent physician and published by the Zenith Radio Corporation.

### FREE BOOKLET

For a free copy, plus descriptive literature on Zenith Hearing Aids, write to Zenith Hearing Aid Division, Dept. 275 5801 W. Dickens Avenue Chicago 39, Illinois

NAME \_\_\_\_\_  
 ADDRESS \_\_\_\_\_  
 CITY \_\_\_\_\_ ZONE \_\_\_\_\_ STATE \_\_\_\_\_

## SAVE \$11.00



NORELCO "Speedshaver" Men's Electric Shaver. Latest model, brand new, fully guaranteed and complete with travel case. Regularly retails at \$24.95. Now on sale for \$13.95 plus \$1.00 mailing costs. All orders filled within 24 hrs. Your money back if you are not fully satisfied. Send check or M.O. for \$14.95 to:

BROOKS, Dept. 19, Box 212, St. Louis 66, Mo.

### YOUR OWN SHOPPER

Thousands of Elk families have learned the convenience and pleasure of shopping by mail through their ELKS FAMILY SHOPPER. Right now, why don't you turn to this month's SHOPPER pages and see all the interesting, attractive and useful items offered—all under the guaranty of a refund if you are not satisfied with your purchase.

## LAW...

**STUDY AT HOME** Legally trained men win higher positions and bigger success in business and public life. Greater opportunities now than ever before. We guide you step by step. You can train in spare time. Degree of LL. B. We furnish all text material, including valuable 14-volume Law Library. Low cost, easy terms. Get full details. Law Training for Leadership and "Evidence" books FREE. Send NOW. ACCREDITED MEMBER, NATIONAL HOME STUDY COUNCIL LASALLE EXTENSION UNIVERSITY, 417 South Dearborn Street A Correspondence Institution Dept. 5328L Chicago 5, Ill.

## BE A CLAIM INVESTIGATOR



**INVESTIGATE ACCIDENTS!** Many earning \$750 to \$1000 a month. Thousands of insurance companies, airlines, steamship lines and Government Offices need Claim Investigators. Also big opportunities for your own spare time business. We train you at home. National Placement Service FREE of extra charge. Bill King writes: "Your course has paid off for me with large earnings. You can quote me — your Adjuster Training Course is worth many times the cost." Write TODAY for FREE book.

### UNIVERSAL SCHOOLS

University Park, Dept. K-5, Box 8202, Dallas 5, Texas

### JUNE ISSUE

Two articles of interest are scheduled to appear in the June issue of THE ELKS MAGAZINE. Our travel expert, Horace Sutton, will write an article on the attractions of Chicago, the city of the 1959 Grand Lodge Convention. There will also be an article by sportswriter Harold Rosenthal about the pennant prospects of the Pittsburgh Pirates in 1959.

something everyone in the family can enjoy? How much more fun is it being skipper of one's own ship than being guest in the fanciest *chateau*? Is a boat worth it? "Ask the man who owns one."

But boating is not an absolute paradise. The boom has had its growing pains and the country still has a way to go before solving all of the problems of protecting 37,000,000 water-sportsmen from themselves and from each other's boating ignorance and enthusiasm (although recently, after considerable effort on the part of industry, government agencies, and boating clubs, important steps have been taken in the direction of sound, sensible legislation and practical training of individuals in boat handling and water safety).

Before World War II boating was largely confined to people who had grown up close to the water. They learned about boats and the water from experience and their fathers' example. After the war the picture changed rapidly. In 1947 there were 2,440,000 recreational boats in use. In 1952 there were 4,333,000. In 1956, 6,686,000. In 1957, 7,071,000. Most of these new boats were owned by people who benefited by the lessons of centuries of boat building only if they were lucky enough to buy their craft from responsible and capable builders. And as for knowledge of seamanship, navigation and water safety—they were shockingly lacking and gravely endangered themselves, their families and other boatmen each time they set out on the water.

Despite these facts, boating was safer, and still is, than driving a car on the highways—if lower insurance rates are an indication of risks involved. But boating accidents were increasing in frequency. Cases of needless loss of life arose on every hand. Boats with engine failure were washed over falls time and again, for lack of an anchor or pair of oars with which to clear the danger. Explosion and fire took boats and lives because of improper ventilation and faulty extinguishers. Inadequate legislation and safety regulations plus lack of means to enforce such laws as existed encouraged delinquency on the part of naturally lawless persons. Nearly everyone who has been out in a boat a few times has witnessed reckless driving. Collisions were all too frequent.

However—fortunately for all—much has been done and is being done to correct the situation.

Day after day training courses in boat handling, water safety and more detailed aspects of good seamanship are being administered free of charge by members of non-profit groups such as the United States Power Squadrons, the U. S. Coast Guard Auxiliary, the Boy Scouts of America, and individual boat clubs all over the country.

The U. S. Power Squadrons, with headquarters at 96 West Street, Englewood, N. J., is currently conducting

80,000 free courses throughout the nation. The U. S. Coast Guard Auxiliary, a civilian, volunteer branch of the Coast Guard with headquarters in Washington, D. C., is conducting 40,000 courses.

The National Association of Engine & Boat Manufacturers, 420 Lexington Ave., New York 17, N. Y., an industry-sponsored organization dedicated to improving the conditions of boat and equipment construction and promoting boating knowledge, publishes instructive literature for free distribution. So does the Outboard Boating Club of America, 307 North Michigan Ave., Chicago 1, Ill., with such titles as "Outboard Handling", "How To Organize For More Fun On The Water", "Financing Outboard Equipment", and many more free booklets. Both organizations also publish a list of 16mm. films on boating and associated subjects, which are available on loan from sponsors who benefit from improved boating conditions.

Another important step in the direction of better boating was taken in the last session of Congress in Washington, with the passage of H.R. 11078, An Act To Promote Boating Safety, better known as the "Bonner Bill" after Congressman Herbert C. Bonner, Chairman of the Committee on Merchant Marine and Fisheries. Now known as Public Law 85-911, it is the first major revision of the nation's boating laws in 18 years, and the first improvement of the boat registration system since 1918. The law provides for proper operation of water craft, and requires that "every undocumented vessel propelled by machinery of more than 10-horsepower . . . using the navigable waters of the United States . . . shall be numbered." Boats will be numbered by the States, according to a consistent overall system, or by the Federal government.

Specific safety requirements are set forth in the Act, and in a broader scope it spells out the need "to encourage uniformity of boating laws, rules, and regulations as among the States and the Federal Government to the fullest extent practicable, subject to reasonable

exceptions arising out of local conditions."

By these means, boating will continue to boom and improve, keeping its place among the safest of sports. Sensible boatmen everywhere know that a sound respect for the other guy and for one's own responsibilities as skipper will solve the important problems of boating. Overcrowded facilities will be relieved by new facilities, and boats and equipment will continue to improve in quality.

And playing together, thusly, people will continue to learn better how to live together. The small town, over-the-back-fence neighborliness which tends to disappear in modern society is reborn amongst a fleet of boats tied up at the same dock, clustered in the same sheltering bay, harbored together against the sea outside the breakwater.

Fact is, many people who have taken to boating for relaxing vacations are retiring afloat—selling out ashore when they reach retirement and living afloat, spending summers in the North, winters in Florida and the Caribbean.

That's something to dream about. These people learned to dream, and they know what Herman Melville meant when he wrote of boating in "Moby Dick": "There is magic in it. Let the most absent-minded of men be plunged in his deepest reveries—stand that man on his legs, set his feet a-going, and he will infallibly lead you to water, if water there be in all that region . . . Yes, as everyone knows, meditation and water are wedded forever."

So likewise are many pleasures and rewards, from deep-sea sport fishing to water skiing, from lying in some quiet cove watching the moon come up on the water to shooting rapids in a canoe. Yes, wherever there is water, someone will be looking for it. For fun, or—like ancient seamen who symbolically emptied buckets of water over their heads to wash away the psychological stains of the shore—for retreat from the irrelevant paraphernalia of day-to-day living. For relaxation. Release from confinement. Introduction to horizons. ● ●

---

## South Carolina Elk Dignitary Passes

THE ELKS OF SOUTH CAROLINA mourn the loss of one of their most prominent leaders, Louis E. Burmester, Sr., who passed away February 22nd, ten days after his 64th birthday.

In 1950, Mr. Burmester became Exalted Ruler of Charleston, S. C., Lodge, No. 242. A driving force in the affairs of the South Carolina Elks Association, he was named as its President in 1954. Three years later, he was elected

to the office of Grand Inner Guard.

A native of Charleston, he attended its schools and was a communicant of the Stella Maris Roman Catholic Church there. Formerly a member of the Sullivan's Island Township Commission, he owned and operated a pharmacy on that Island.

Surviving are his wife, a daughter, a son, two grandchildren, a brother and three sisters.

---

## Change of Pace

(Continued from page 6)

a mark on the ground. Woody the great reporter got him to tell the whole story and we read it in the paper that week. 'I was standing there hosing down Mr. Fletcher's Buick,' George said in the paper, 'when all of a sudden I heard the crack of the bat and I said to myself, that one is surely hit, and a second later the ball landed with a smack and took one skip-hop and flew into the garage. I marked the spot with my heel and carried the ball back to the field.'

Woody took pictures of the place where the ball had hit and had a picture of George and Mr. Reilly and Lenny's father all standing there holding the ball up in the air and grinning like three kids eating jellybeans.

Well it measured close to 480, although I personally don't believe it went that far. I believe that George was either mistaken or bribed, or that Mr. Baron cheated with the tape measure thing, or that maybe there was more wind than anybody figured. I told everybody that 480 was an awful lot and that there were a lot of big leaguers that couldn't even pole one that far, much less a mere sandlotter like Lenny. But my voice was just a murmur in the crowd you might say. The paper ran it all over the front page, all about Lenny Baron's colossal clout. Malarky like that. I don't know how they can get away with it.

Well, let me tell you something else. 420 and 480 are all right—but they don't mean a thing. I'll tell you why. Who did he hit them off? He hit them both off of Skinny Wilson who can't pitch baseball any better than your grandmother. I'll tell you this—he never hit anything like that off of old Henry Price, because I know how to pitch him. Anybody can hit a long ball today if the pitcher is second-rate. I told that to Lenny. I said: "You never hit one of those flying saucers off of me and you never will—because I know how to pitch you." But he's a wise guy, like his old man, and he just scoffed and said: "You get back in there then, Henry, and we'll put it to the test."

And believe me, the only reason Lenny hit those lucky ones was because I wasn't in there. I had a bad back which I had hurt helping my father carry ashes out of the cellar and it affected my natural motion, and so the skipper said Henry take it easy for a couple weeks, because I guess I'm too valuable for the club to take any chances with. But this business was too much. I told the skipper I was ready to pitch again, that I wanted to go against Lenny's club on Sunday and take some of the wind out of that boy's sails. Lenny's club and my club were just about the best in the county and so we played each other quite a bit. Once in a while we'd go

# DO YOU OWN OR MANAGE A STORE?

Often, prospective advertisers for THE ELKS MAGAZINE request information concerning the number of Elks who are owners or managers of retail stores. Of course, the larger the number we can quote, the stronger is our portrayal of THE ELKS MAGAZINE as a forceful advertising medium.

If you have not returned the coupon below, will you please do so today. The return of the coupon will be of material assistance to your MAGAZINE.

●  
THANK YOU—In response to a facsimile of the dealer coupon displayed here, Brother John J. Cummings, PER of Ridgewood, N. J. Lodge No. 1455, now residing in Toms River, N. J., and Brother Walter F. Kelly, Sr., Secretary of Toms River Lodge, jointly sent THE ELKS MAGAZINE a list of all Toms River members engaged in retail business.

THE ELKS MAGAZINE takes this opportunity to thank Brother Cummings and Kelly and the hundreds of members who have returned the dealer coupon.

---

### THE ELKS MAGAZINE

386 4th Avenue, New York 16, N. Y.

MY NAME IS \_\_\_\_\_

ADDRESS \_\_\_\_\_

CITY \_\_\_\_\_ STATE \_\_\_\_\_

TYPE OF BUSINESS \_\_\_\_\_

(PLEASE CHECK BELOW)

I OWN THIS STORE

I AM PART OWNER OF THIS STORE

I DO NOT OWN BUT MANAGE THE STORE

## YOU'LL WONDER WHERE YOUR BELLY WENT



### —when you relax in your **PiPee SLIM-R HEALTH-BELT**



**\$498**  
postpaid

Take inches off your waistline, feel like you've taken years off your age! SLIM-R's broad, powerful elastic belt pulls in sagging stomach muscles, holds internal organs in proper position. Improved posture relieves back strain, clears up painful backache almost instantly. No-gauge stays prevent wrinkling, rolling. Detachable pouch for easy laundering. Elastic fabric "gives" with body movement—no corset-like pressure. 30-day money-back guarantee. Order today—next best thing to the fountain of youth! Send waist measure. Check or money order. \$4.98 postpaid. Buy two—one for change-off—and get a third pouch support FREE.

Piper Brace Co., Dept. EK-59R  
811 Wyandotte Kansas City 5, Mo.

## How To Hold FALSE TEETH More Firmly in Place

Do your false teeth annoy and embarrass by slipping, dropping or wobbling when you eat, laugh or talk? Just sprinkle a little FASTEETH on your plates. This alkaline (non-acid) powder holds false teeth more firmly and more comfortably. No gummy, goeey, pasty taste or feeling. Does not sour. Checks "plate odor" (denture breath). Get FASTEETH today, at drug counters everywhere.

### FREE BOOKLET "MY ROAD TO HEALTH"

Teresa Mitchell's fascinating story of her personal experience in triumphing over illness and regaining vibrant health and vigor through Prof. Ehret's Diet System. This could mean much to you. For your free copy send postcard to Crowell Dist. Co., Beaumont 19, California

## FREE FOR ASTHMA

If you suffer asthma attacks, choke and wheeze, find sleep impossible because of the struggle to breathe... try FRONTIER ASTHMA MEDICINE now! Get immediate, blessed relief from the dreaded symptoms of bronchial asthma. Over 1,000,000 bottles sold. FREE TRIAL bottle by return mail. You pay nothing. Send name and address now to: FRONTIER ASTHMA CO. 886-A Frontier Bldg., 462 Niagara Street, Buffalo 1, N.Y.

## RUPTURED?

**NEW LASTING RELIEF**

ENJOY NEW FREEDOM

Yes, enjoy freedom of action, peace of mind and comfort at work or play. Proven, patented MILLER holds your rupture back Day and Night—will bring you lasting relief, has helped thousands. For FREE facts in plain wrapper. Send Name and Address To: FRED B. MILLER, Dept. 44-E Hagerstown, Maryland

ENTIRELY DIFFERENT

Exclusive Manufacturer

Get FREE FACTS

## WHEN FALSE TEETH CAUSE SORE GUMS

You get undreamed of relief in seconds! Medically-formulated NUM-ZIT Adult Strength has already brought blessed relief to thousands. Recommended by dentists everywhere. Pleasant-tasting... eases discomfort while you break in new false teeth. Works wonders, too, for relief of toothache, neuralgic pains. Keep it handy for quick first aid. At all drug counters.



**NUM-ZIT Adult Strength**

into the next town to play somebody different or they'd come to us, but it was mostly against Lenny's team. The people never got tired of us though because there was a lot of rivalry, like between different drug stores and stuff like that; and another thing I have to admit was true was that a lot of people were hearing about Lenny the slugger and were coming out to see him hit one. One day I fanned fifteen of those beauties and Woody didn't even mention it. Not that I care though.

Anyway that Sunday it rained. I was really rarin' to go too. But it rained all day. So what do you think that phony Woody does, with no impossible home runs to write about? He rewrites the story, does the whole thing up again. Only this time he ignores 480 and says that the boy's legendary clout (get that—legendary—the boy hasn't even begun to shave yet) went almost 500 feet.

So with this kind of propaganda running in the paper for three weeks in a row something was bound to happen. And it sure did. Woody got a call at the paper on a Friday from a fellow who said he is a big league scout and wants to know who is this boy Baron. Well naturally Woody sold the scout a bill of goods, saying that every big league club is after the boy and that this fellow had better get down here for Sunday's game. The scout said he would be there.

So naturally in five minutes everybody in town knew about it—which I say is the wrong thing, because if a fellow knows that a big league scout is going to be there then he's just naturally going to tighten up a bit and maybe even get the apple. But here's Woody running up and down the street like a madman telling everybody that a big league scout is coming down to see Lenny Baron play on Sunday. Everybody in town acted like they were on the other side of sober. Nobody, not even Josh Pepper who is ninety-four, could remember a big league scout ever coming to town. I walked around and told everybody to be calm, that it didn't necessarily mean anything. But nobody listened to me, because after all who was I? Only the boy that was going to be pitching to Lenny Baron, that's all.

And what was the object of all this furor thinking about it? Well Lenny-boy was pretty cocky. I ran into him in the drug store on Saturday night. He was sitting in a booth with three girls (one of whom used to sit with me before the era of the 500 foot home run) and he was gassing off about what he was going to do tomorrow, which wasn't very sportsmanlike because after all I was going to be the pitcher.

"Lenny," I said, "you'd better get a good night's sleep because this isn't Skinny Wilson you're facing tomorrow."

"Oh no?" he said, standing up one of his eyebrows the way he does, which irritates the devil out of me.

"No," I said. "Henry Price is coming

back. And if you'll check your scrapbook you'll note that I not only have your number but your whole pedigree,"—which I thought was pretty clever.

"You'd better pitch with shin guards and chest protector on, Henry," Lenny said and the girls giggled. They'll giggle at anything.

"You can't hit 'em if you can't see 'em," I said.

"Don't be choking up when that scout comes out," Lenny said.

"Choke up?" I said. "We'll see who chokes up."

"Yes," Lenny said, real cool. "We'll see."

"When that scout leaves here tomorrow," I said, "he won't even remember your name."

"We'll see," he said, playing it real cool for the girls, making it look as if I'm the one who's gassing off.

So the next morning everybody was down at the station waiting for the scout to come in. Mr. Baron was all dressed up, and Woody was there and coach Morgan from the school and just about every popcorn in town. I was down there too with the rest of the guys, but just for curiosity's sake. I wanted to see them all making saps out of themselves. I read about these scouts. They're real sharp customers. You can't snow them with talk or phony newspaper stories. You've got to produce.

So the train came in and I knew right away this fellow is the scout, but Woody and Mr. Baron ran up to some guy in a sport jacket and shook hands with him. The scout was a little guy, kind of seedy looking, but he had those shrewd little eyes that they all have. His name was Joe Bell, an ex-ballplayer who was up in the big time for a little while. When everybody was finally done shaking hands with the fellow in the sport jacket, Joe said to somebody: "Who is Mr. Woodfield?" Then Woody and Mr. Baron rushed over to him and took his hand and shook it up and down and back and forth like they were trying to get water out of him. I could tell right away that Joe didn't like this phony business, that the only way you could impress him was to produce. But try and tell that to Mr. Baron. He had Lenny there and made him shake hands with Joe. Joe looked him over with those little eyes and I had the feeling that Joe didn't like him.

"That's the boy who hits them five hundred feet," Woody said. Joe just nodded. He wasn't impressed.

So naturally Mr. Baron took Joe home with him for lunch and then drove him out to the field in his big limousine. Me and my father, we came out in our old crate. My father's okay. He comes out to see me pitch every time although he really doesn't care too much for the game. And when I chuck a good one he feels just as proud as Mr. Baron, except that he doesn't go wind-bagging all over town about it. I guess maybe it's

because my father works for Lenny's and Lenny is supposed to be the only ballplayer in town.

I'll swear that the whole town was out there. Joe sat down right behind our bench and just before the game I went around and introduced myself. I figured that because I was pitching it was the polite thing to do.

"I'm Henry Price, Mr. Bell," I said. "I'm pitching for the Gaels."

"That's good, Henry," Joe said. He shook hands with me. He was a real swell guy.

Just before the game a guy came up in a sound truck—it must have been Woody's idea—and played a recording of the National Anthem, just like a big league game.

Then we started off. It wasn't that I had anything personal against Lenny or anything, but I said to myself that he wasn't going to pole any 500 foot home runs off of me. I felt it when I was warming up. I was real fast. You can feel that sometimes, even before you throw a ball, just by the way the ball feels in your hand, nice and light. And I always had a good curve, so I knew I was going to give Lenny-boy a good afternoon. Joe watched me warm up, too; I could catch him out of the corner of my eye. Naturally I didn't look straight at him like most of the guys were doing. That's bushleague. You don't get any contracts by waving your arms or yelling or running up and down in front of a guy. You got to produce.

The skipper of the other team put Lenny up second so he could get as many at bats as he could. He always batted fourth, although just between you and me I always thought there were a couple of other fellows on the club who were much better hitters than Lenny. But let them do it their way.

I got their leadoff man on a little grounder and then Lenny the Legend stepped in. I played it real cool. I let him wait because I knew he'd be anxious. Well he was. He knocked the dirt out of his spikes and dug in real fierce and pumped the bat and was pretty fidgety, but I just stared down at him real cool. I think Joe must have liked that. They call that poise, I think.

Well, like I said, I was real fast. I don't think I was ever any faster than that day. I was really pumping them, from way back, and throwing easy too. Lenny took three big swings and sat down. When I walked back to the bench at the end of the inning I could see Mr. Baron waving his hands and trying to explain to Joe how the whole thing had happened. Joe was nodding, business-like, and polite, too, like a guy cornered by a bathtub salesman.

"He takes a level swing," I heard Joe say.

"He's a little over-anxious," Lenny's father said. And Woody kept nodding up and down and saying something about the sun being at a certain level.

Well I don't know what they told Joe the next time, but I would love to

## Georgia Elksdom Mourns Bruce Jones

IN THE DEATH of Bruce C. Jones, Elksdom has lost a loyal and devoted member. He passed away February 6th, following a brief illness, at the age of 81.

Mr. Jones had been a member of Macon, Ga., Lodge, No. 230 for over 50 years. Its senior Past Exalted Ruler, he had ever been an active participant in its activities. He was also the senior Past President of the Georgia Elks Association, and his deep and abiding interest over the past 20 years was in "Aidmore", the Georgia Elks Crippled Children's Hospital, and in the charities of his own lodge, as well as in various other fraternal and civic activities and charitable enterprises. He had also been a member of one of Macon's leading law firms for more than half a century.

He had been deeply active in Boy Scout work for many years, and had served as President of the Central of Georgia Council of the Scouts and had received the Silver Beaver award. He was also a Past Potentate of the Al



Sihah Temple of the Shrine organization and a member of the Methodist Church for 65 years.

He is survived by his daughter, a sister and two grandchildren.

# SPECIAL INVESTMENT OPPORTUNITY in Sunny, Tropical, South FLORIDA

**5 ACRES TROPICAL FLORIDA UNBELIEVABLE PRICE \$595**

Equal to 16 Big residential lots  
75' x 135' (each lot 10,000 sq. ft.)  
**PAY ONLY \$10 MONTHLY**  
**• NO INTEREST AND NO OTHER COSTS**

Here's another special opportunity offered to every member of the Elks family! In a section of the State of FLORIDA where "The Boom is Bound to Come!" For many years, we have been predicting that a shortage of usable land in South Florida was imminent! And today the FACTS ARE BEARING OUT OUR PREDICTION! Greater Miami has expanded so rapidly in the past 10 years (the population estimated to double from 1958 to 1968) that a critical shortage now exists for residential and commercial land in Dade County, (Metropolitan Miami).

The surge in population and industry has pushed westward to a point where not only the western limits of Dade County, but also the neighboring counties of Collier and Monroe are destined to become part of this miraculous South Florida development.

61 of the nation's top financiers recently visited Miami and saw through their investment wise eyes why South Florida is possibly the hottest spot in the nation for growth.

The Miami Herald quoted several of these financiers including Alfred Mante, of the Smith-Barney Corp., who stated "It's Fantastic—there is no question about the future—it will be just tremendous!" and Robert S. Davis of the St. Paul Fire & Marine Insurance Co. stated, "you've just begun to tap the industrial possibilities."

We offer you this opportunity to invest in property which, in our sincere opinion, will bring you BIG PROFITS! This land is undeveloped with no roads at present, as speculative acreage should be—or else the price would be far higher. But it enjoys higher elevation than Miami Beach and many other famous South Florida areas; and has just become available to the limited income buyer in small tracts. Think of it! You can buy 5 Acres (title insurable) for only \$37 land cost per lot (16 lots—75' x 135') and wait for future progress to push the value upward.

Invest today, be ready when PROGRESS COMES TO YOU! To aid in your security and the future security of your loved ones, mail this coupon today. Send \$10. You take no risk, rather you be the judge. You must be satisfied or every penny is promptly refunded!

**32 years in Florida Real Estate  
Thousands of Satisfied Clients**

**WEBB REALTY CORPORATION** E5  
639 N.W. 102nd Street, Miami 50, Florida

Enclosed is \$10. Please reserve my 5-acre Collier tract. Send contract, map and data. If I am not fully satisfied that this is a BIG profit opportunity after receiving complete details, my money will be refunded at once.

Name.....  
Address.....  
City.....Zone.....State.....  
Member Miami-Dade Chamber of Commerce.

### IN SPRING, A YOUNG MAN'S FANCY TURNS . . . CAN BE WRONG TURNS

He needs a HULL AUTO COMPASS, the original motoring guide, that reveals wrong turns, the instant they happen, for thousands of motorists every day. \$5.50 and \$6.95. At your dealer's or write for literature.

Famous Compass Makers for Motorists and Boaters  
HULL MFG. CO., P.O. BOX 246-EE-4, WARREN, OHIO



### BOOK OF MEMORY

**in everlasting bronze**

For listing 100 to 3000 names economically. Write for free catalog including photos of hand-chased cast bronze plaques.

**NEWMAN BROTHERS, Inc.**  
Dept. 722, Cincinnati 3, Ohio

## Looking Behind the Red 21st Congress

TO FIGHT an enemy effectively, one must know something of that enemy's plans and strategy. It is therefore of the utmost importance for free people everywhere to know what goes on at such meetings as the recent 21st Congress of the communists—today's greatest enemies of freedom. At that meeting two important facts were made clear: first, that communism's aim remains, implacably, world domination; and second, that party members and sympathizers in every nation, including our own, are helping to further this aim. A recapitulation of the Soviet conclave is contained in this month's excerpts from Freedom's Facts—monthly publication of the All-American Conference to Combat Communism. The Conference, which consists of fifty national organizations, including the B.P.O.E., publishes these facts to help guard our democracy.

An American Communist rose to his feet in Moscow, February 2, 1959, to praise the work of the Soviet Party's 21st Congress. This gesture—by U. S. Party National Committee member James E. Jackson—means more than might appear at first. Soviet Premier Nikita Khrushchev had just announced at the 21st Party Congress that Communists were now leading the Soviet Union to supremacy over the entire capitalist world, including the United States; and that Communists in all countries "had not and should not have any different views or different understandings of the struggle against imperialists and the exploiters" from those issued from Moscow.

So, in effect, U. S. Communist James E. Jackson was offering allegiance of U. S. Reds to the Communist Party of the Soviet Union run by Soviet Premier Khrushchev. No matter how you look at it, this confirms U. S. Communists' loyalty to a foreign regime.

The purpose of the 21st Party Congress was much more serious than has been reported by the American press. A reason is that much of what was said in Moscow in January was phrased in hard-to-understand Communist theoretical terms. In simple terms the 21st Party Congress was called to announce that the Soviet Union has entered a period of all-out building of Communism. This means that there will be many changes inside the Soviet Union. These will include: stepped-up efforts to educate "a new type of man" who can live under Communism; increased efforts to boost Soviet farm and factory production; and

gradual change from distributing goods on a basis of the work a man does to a basis of the man's or woman's need.

Building Communism also means the defeat of capitalism everywhere in the world. Khrushchev made a special point that: "Only on condition that we outstrip the developed capitalist countries in production level and insure new and far higher productivity of labor than under capitalism will Communism be realized." This brings up to date Lenin's classic theory that Communism will conquer the world when it can outproduce capitalism. Furthermore, in Khrushchev's view, the Communist world already has caught up with the world capitalist system in per capita industrial output. The job of the new seven-year plan is "to tip the scales of world production in favor of the socialist system against the capitalist system." At the point where the scales begin to tip in the Communists' favor, Khrushchev figures Communism will be on the home stretch toward world victory.

Communists from all over the world who attended the 21st Party Congress came away with the conviction that soon the Communist banner "from each according to his ability and to each according to his need" will fly above the Soviet Union and the whole Communist camp, and that this banner will attract all the working people of the world to Communism. This, true Communists feel, will shatter capitalism. So, today, Communists are fully confident that the future of the world indisputably belongs to Communism.

Khrushchev has made this statement to his Party's Central Committee:

"We will leave the capitalist world far behind us. Our country will then win over the universe by giving its workers the highest living standard. Capitalism will fall like a dead branch from a tree."

This confidence will make it more difficult, rather than less difficult, to deal with Communists in the future. They will expect us to surrender to their self-proclaimed superiority. They will regard any opposition to their demands as incitement to war.

In the wake of the 21st Party Congress, you can now expect an upsurge in propaganda to surrender to Communist proposals, which will be aimed toward ultimate destruction of our independence and our way of life. Strong and determined people will be needed to win the day for freedom in such a contest.



have heard. I got Lenny on three curves this time. He was looking for the fast ball on the last one but I played his game and crossed him up with a curve across his knees on the inside that he didn't even swing at. He threw his bat about fifty feet in the air and believe me it was pretty quiet in the stands. I don't know what his father said that time, except that maybe his boy had a lot of form in taking a pitch.

I would like to mention that Lenny wasn't the only one who was seeing third strikes. By the sixth inning I had cut down nine of those beauties on strikes. But I wasn't showing off. Each time I walked back to the bench and I kept my eyes down, just like a pro. Once, though, I stole a glance at Lenny's father and Woody and they were sitting next to Joe like two hungry cocker spaniels.

Next time Lenny came up I could hear his father and Woody yelling for him to hit one. It was the first time I ever heard Mr. Baron root like that. And Woody, the phony, should have stood neutral. But I didn't care. It gave me more determination. I could tell that Lenny was guessing this time. You can tell when a hitter is guessing, the way he moves his feet around with every pitch. Joe must have saw it too and they don't like that in a hitter, guessing.

Well the boy guessed wrong. He fouled one off this time, straight up in the air that caught on the backstop. I was glad it did because I wanted to whiff him again. I got him with a beautiful pitch. I set him up with a fast ball right in close on the letters that he chopped at like somebody's grandmother. And then I fired this curve, a real honey. I can still see it bending and sweeping like a good curve ought to, cutting low over the outside corner. He swung all right—but he had been laying back for the fast ball, I could tell. He never stood a chance. He took that real pretty swing of his and missed by I swear a foot. He threw his bat into the ground and really glared when he went running by to the outfield.

And then what do you think began to happen? Mr. Baron, who I knew must really be fit to be lashed, started to pull rank. He went over, his face all white, and told my father that this is terrible, terrible, that what is happening is a disgrace to the town. My father knew right away what he wanted. I really can't blame my father. He works for Mr. Baron you know, and when a guy is paying you money you naturally feel a little funny with him. Not that Mr. Baron said it in so many words. But my father is no dope. Between innings he slipped down to the bench and whispered: "Henry, Mr. Baron is furious."

"I can imagine," I said with a chuckle.

"I don't know what'll happen if you strike Lenny out again."

"Well you just wait and see," I said,

"because it's going to happen once more."

"Henry," he said, quiet, just like that, a little scared.

I knew what it meant. It was outright blackmail. But my father had to work for Lenny's father the next morning.

"All right," I said. "I'll let him hit one."

"Mr. Baron said it would be nice if you threw Lenny a slow one."

"It ain't right, Dad," I said.

"I know, son," my father said.

"But okay," I said because I didn't want to put my father in Dutch, he's a terrific guy. "Go back and tell that hypocrite that I'll give his son a slow one," I said. My father patted me on the shoulder and went away.

When I turned around I could see Mr. Baron sitting there all smug and ready. It was a real squeeze play.

**W**ELL, now here's the kicker. I knew Lenny-boy was going to get a slow one, and my father knew it and Lenny's father and that great sportswriter Woody knew it. But I guess us schemers forgot to tell Homerun Lenny about it when he came up in the ninth. He was really glaring through his teeth this time too. As usual I whipped two quick ones right by the boy—just to show them that I could do it if I wanted—and then I stepped back and looked over at Mr. Baron and my father in the stands. They were leaning forward in their seats, waiting for the big 1000 foot clout. I touched the peak of my cap to kind of tell them all right, that the fix was in.

But meanwhile there's Kid Lenny down at the plate, dug in almost to his knees, that bat set behind his ear like a cannon.

I took the big windup, gave him the big motion and brought my arm around fast, but was holding the ball back loose in my hand and let up at the last second and just eased it in there. You couldn't have asked for it to be any slower. I mean I kept my end of the deal. She was floating in there for the strike too. You should have seen good old Lenny's face. And that bat. That bat got the shakes. It started and it stopped. It went back while Lenny went forward. It came forward while Lenny was falling. It was pitiful. I mean it was pitiful. I don't think he ever did swing. He wound up flat on his face.

It wasn't my fault at all. I couldn't go up and hand it to him could I? I even looked over at Mr. Baron and my father and shrugged. They didn't shrug back though.

As soon as I cut down the last man Joe Bell came running out of the stands and grabbed my hand.

"Nice game, Henry," he said. "Very nice game."

Everybody was hitting me on the back and saying the same thing except Lenny's father and that phony Woody. And except my father too, who really didn't know what to do.

Anyway Joe was so impressed that he got me a thousand dollar bonus when I went up to the city to sign the contract. The money came in real handy too that winter while my father was looking for a job. • •

## Prominent New York State Elk Dies



LOUIS R. DOWD, a member of Cortland, N. Y., Lodge, No. 748, for nearly 38 years, passed away at Cortland Memorial Hospital on March 3rd. He was 69 years old.

A devoted and active member of the Order from the time of his initiation, Mr. Dowd was appointed Chairman of his lodge's Charity Committee in 1923 and continued in that capacity without interruption for well over a quarter of a century. Mr. Dowd was elected Exalted Ruler of his lodge in 1928, the same year he served as Vice-President of the South Central District for which he was District Deputy in 1930-31. He was also a Past President of the area's Past Exalted Ruler's Assn.

Throughout his Elk career, he took a leading part in the affairs of his State Association, serving on several of its committees; in 1944, he was elected President of that group, and in 1945, he was appointed to the Grand Lodge Committee on Lodge Activities.

He was also a Past Grand Knight of the Knights of Columbus and had served his community both as City Judge and as Prosecuting Attorney.

Surviving are his wife, a son, brother and grandson.

Have you tried  
this better way  
to clean  
**DENTURES?**



New

**Dr. WEST'S**

INSTA-CLEAN\*

**DENTURE CLEANSER**

- Removes sticky film, tartar-forming substance and odor-breeding bacteria in just 2 to 5 minutes!
- A liquid—not a powder—dissolves instantly!
- Leaves refreshing "breath of mint." Month's supply, 69c at drug counters.

**SPECIAL OFFER:** Get 5 Trial-Size Packs Dr. West's Insta-Clean Denture Cleanser plus Lifetime Denture Bath. Mail 25c to Weeco Products Co., Dept. EM-45B, 20 N. Wacker Dr., Chicago 6, Illinois.

\*INSTA-CLEAN is the trademark of Weeco Products Co.

**The BALL CLINIC**  
Dept. 759, EXCELSIOR SPRINGS, MISSOURI  
Specializing since 1919 in the treatment of Rheumatism, Arthritis and associated chronic conditions.

WRITE FOR FREE BOOK TODAY!

**REAL ESTATE**  
**BE A BROKER**  
PAYS BIG! SEND FOR FREE, BIG, ILLUSTRATED CATALOG NOW! Graduates report making substantial incomes. Start and run your own business quickly. Men, women of all ages, learn easily. Course covers Sales, Property Management, Appraising, Loans, Mortgages, and related subjects. **STUDY AT HOME** or in classrooms in leading cities. Diploma awarded. Write TODAY for free book! No obligation. Approved for World War II and Korean Veterans.  
**WEAVER SCHOOL OF REAL ESTATE** (Est. 1936)  
2020H Grand Avenue Kansas City, Mo.

**ACCOUNTANT**  
**BECOME AN EXPERT**  
SEND FOR FREE SAMPLE LESSON  
Executive Accountants and CPAs earn \$5,000 to \$10,000 a year and up. Thousands needed. We train you thoroughly at home in spare time for CPA examinations or executive accounting positions. Previous experience unnecessary. Personal training under supervision of staff of CPAs and Expert Accountants. Write for free book, "Opportunities in Accounting" and sample lesson.  
**LASALLE Extension University, 417 So. Dearborn St.,**  
A Correspondence Institution, Dept. 5328H, Chicago 5, Ill.

# ELKS HOME WORKSHOP

By HARRY WALTON

## Getting Garden Furniture Ready For The Summer

WITH another season's use ahead of it, last year's garden furniture may need a check-up. Weather and stress can loosen rungs and rails, crack slats and legs, rot canvas and rope webbing. But though outdoor furniture is vulnerable to sun and rain, it is usually easy to repair.

When glue is used, it must of course be a waterproof type. The water-mixed plastic-resin kind will do; the resorcinol type made for marine use is even better. Be sure to mix either according to directions on the container, and to put the work in a warm room (at 70 degrees minimum) while the glue is setting.

Copper tacks, copper or aluminum nails, and zinc-coated, aluminum or brass wood screws are worth their extra cost for outdoor repairs. Not only will they last longer than iron and steel fastenings, but they will spare the surrounding wood from deterioration. A rusty bolt or bracket, on the other hand, speeds decay by holding dampness near the wood, and a rusted pivot bolt rapidly wears the wood in which it works.

**TO TIGHTEN LOOSE JOINTS** in wooden parts, see first whether they can be taken apart easily. There may be a nail or screw still holding them. If it can be removed, do so. If not, work glue into the joint with a bit of

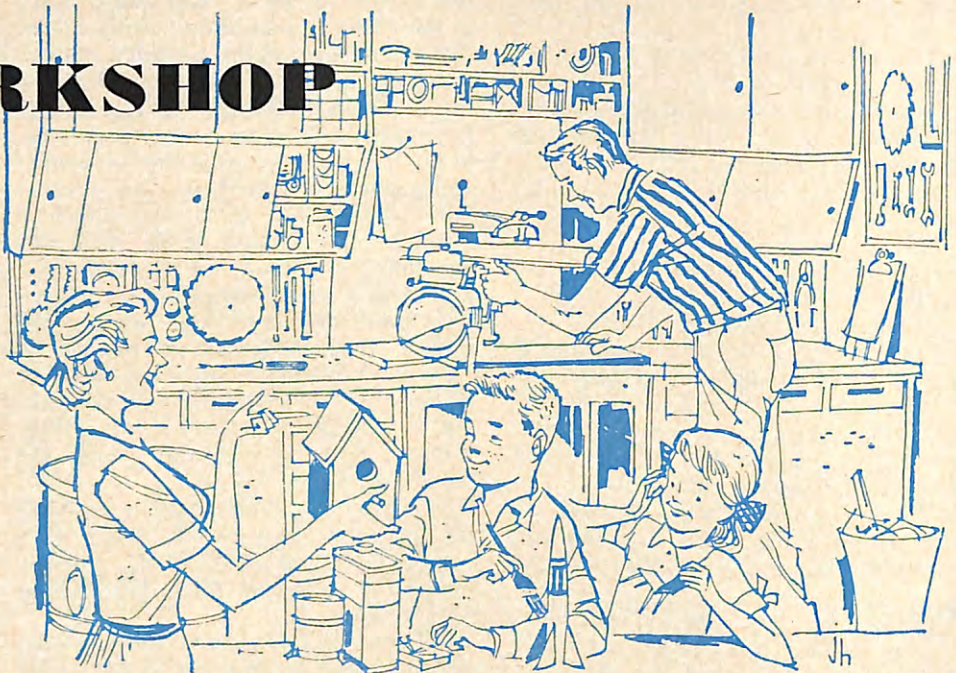

wire and drive another nail, or better still a screw, where it will reinforce the joint.

Disassembling the parts will make it easier to apply glue properly. Slight looseness where a rung fits into its socket can be taken up with a cloth patch. Simply place a glue-soaked disk of cloth over the end of the rung. After pushing the rung in, trim off any cloth that shows. A loose rung or rail may also be slotted with a saw as in Figure 1, glued into its socket, and then spread with a wooden wedge, also glued in. Cut the slot so that the wedging effect will be along the grain of the socket as shown, not across it.

Rectangular tenons can be wedged in the same way, or more simply by inserting thin slips of wood between them and the walls of the mortises (sockets).

**USE METAL REINFORCEMENTS** where space permits. A flat right-angle bracket (A in Figure 2) may be mounted on one or both sides of heavy frame joints. Ordinary angle irons, which come in several sizes, are used inside corners as at B. On smaller members or for a neater appearance, the stamped bracket at C is preferable. Protect iron brackets by painting them, preferably before installation. Use only rust-resistant screws—never nails—to attach them.

A split slat or rung not subject to great strain may simply be glued together. Draw the split shut with a temporary binding of soft cord or rubber-covered wire as in Figure 3. Drive in wedges or simply twist the cord in order to tighten it.

Splits that will be under strain, like the chair member shown in Figure 4, require reinforcement. Work in glue with a fine wire, squeeze the split together with a C-clamp, and drill for

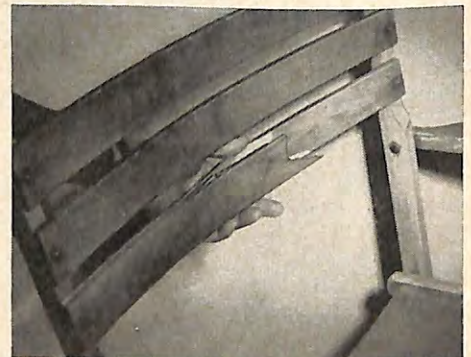

So badly broken as to be unrepairable, the plywood slat in this folding chair was removed by drilling out the hollow-head rivets that held it. A thin strip of wood from the side of a fruit box was ripped to slat width but left extra long. Steamed in front of a kettle for 10 minutes, it was sprung into a curve between two blocks nailed to a board and left overnight. Then it was clamped to the chair back, fastened with two screws at each end, and cut to length.

a wood screw as shown. Once the screw is in tight, the clamp can be removed and the split won't open.

**REPLACING BROKEN MEMBERS,** or those so badly split or rotted as to be beyond patching, is less difficult than it may seem. Such parts must of course be removed, and this may be the hardest part of the job. If rusty bolts defy loosening, apply penetrating oil to the stubborn nuts. In hopeless cases, hacksaw through the bolt shanks or chisel the nuts off. Use the defective piece as a pattern for cutting an identical one from good lumber.

If only the end is rotted, which is common, you might consider bolting on side pieces as shown in Figure 5. They should extend well up to sound wood;

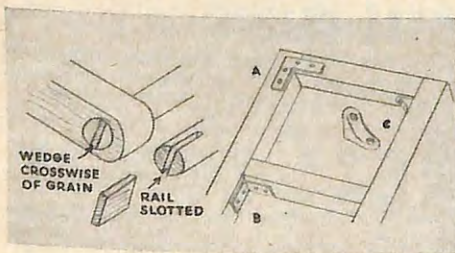

Figures 1 and 2

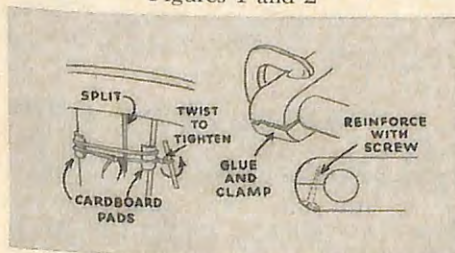

Figures 3 and 4



the upper ends should be sloped in order to shed water.

A new section can be spliced on in place of a damaged end as shown in Figure 6. Clamp a piece of wood of matching thickness and width alongside the member. Saw through new and old pieces simultaneously at a slope. Glue and screw on the new piece and trim it to length.

Broken rungs and rails can be glued and strengthened with nails, screws, or a wrapping of brass wire tacked fast at both ends. For new pieces, use hardwood doweling of the same size or slightly larger than the old. The ends can be whittled or shaped with a rasp to fit into the sockets.

Damaged plywood parts should be replaced with new ones cut from exterior grade plywood. Thin solid lumber from fruit boxes can also be used. Bent shapes are rather difficult to form satisfactorily, but one way is to hold the piece in front of a kettle spout until steam has penetrated the wood fibers enough to permit bending.

The framework of rattan furniture can be repaired by the same methods once the rattan covering has been carefully unwound. Apply glue before wrapping the rattan back on. Hold the end of it with tape or cord until the glue hardens, or insert the end under a previous turn and pull it tight.

Damaged slat, reed and cane seats are difficult to repair. But it is easy to buy a replacement seat or to cut one from hard composition board or the perforated kind. Fasten it with upholstery nails over the damaged seat.

**SPLIT WOODEN WHEELS** on lounges and other heavy pieces are often beyond repair. New ones can be cut from thick boards, but a better way is to glue together two thicknesses with their grain at right angles. Without a power saw, cutting out a thick wheel is slow work. One way to do it is to cut the

## ELKS WORKSHOP TIP

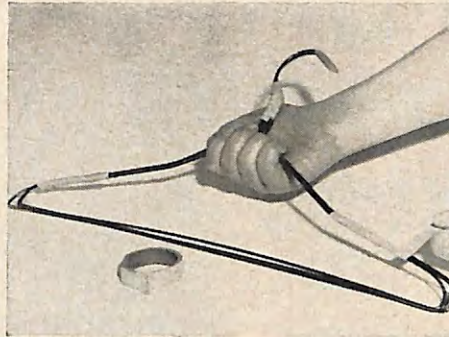

### FOUND:

#### A Use for Wire Hangers

After cutting the hook off one, tape it and two others together tightly at the neck and both ends. Tape the doubled hook together or slip a bit of rubber tubing over the two wires. No longer flimsy, such triple-strength hangers will hold heavy garments and make handy extra hangers for storage or company use.—HARRY WALTON.

corners off with a straight saw, and then use a rasp to shape it.

Rubber-tired metal wheels from old toys or garden implements, or new replacement wheels of that kind, make excellent substitutes.

**REMOVING HARDWARE** such as the brackets and pivot pins used in folding furniture calls for a few metal-working tools. To get out riveted pins, file off hammered end (A in Figure 7) or drill out hollow spread ends (B). Then drive out the pin with a thick nail or a small punch. Replacements for damaged brackets are not easy to find, but you may be able to saw and file one out of a flat mending plate, angle bracket, or plain sheet steel.

Aluminum rivets up to 3/16" diameter are now available. For larger pins, obtain long stove bolts and saw off the threaded ends. Always put close-fitting washers on before hammering the ends over, especially when using such fasteners on wooden parts.

**TUBULAR FURNITURE** sometimes breaks where holes have been drilled for joining parts. Whole new pieces can be shaped from aluminum tubing or the light steel tubing called conduit that is used by electricians. An electrical shop may be willing to make a duplicate if you bring in the original as a pattern.

A way to repair broken tubular members is shown in Figure 8. Sandpaper

## Model Changeover Sale

### 8" TILT ARBOR POWER SAW

1958 MODEL  
BLADE TILTS  
TABLE ALWAYS  
REMAINS LEVEL

Comp. As Shown  
Less Blade

Heavy duty all cast iron and steel construction, Precision ground cast iron table. Price includes massive cast iron mitre gauge and patented motor drive that fits any motor. Does everything same as saws costing 4 times as much—cross cuts, rips, bevels, mitres, dadoes, cuts compound angles. Adjustable depth of cut: 0" to 2 1/2". **SPECIAL BARGAIN** during model changeover. This is a 1958 model. Brand new—sent to you in factory sealed cartons. Sold and guaranteed direct from factory at a fantastic bargain during changeover of assembly lines to 1959 models.

**MONEY BACK GUARANTEE**—Try this famous saw 10 days. If not completely delighted—FOR ANY REASON—return for immediate refund.

**SEND EXPRESS COLLECT**—Send check or M.O. \$2.00 deposits on C.O.D.'s. We reserve right to refund money if stock is exhausted. Avoid disappointment. Order right now!

AMERICAN MACHINE & TOOL COMPANY  
Royersford 11, Pa.

## BUY DIRECT FROM-FACTORY SAVE MIDDLEMAN PROFITS

**MASTER MECHANIC PORTABLE LIGHT PLANTS**  
(Item 24)  
Push Button Start—700 watts 115 v. 50 cps. AC. Powered by a rugged 2.2 hp. easy starting Briggs gas engine. No wiring necessary. Just plug in and operate. Plenty of current for any radio, television, oil burner, freezer, pump, lights, etc. which require up to 700 watts. Ideal for camp, cottage, trailer or boat! Includes voltmeter and built-in winding to charge 6 v. auto batteries. Wt. 75 lbs. Easily fits in car trunk. Be prepared if storm knocks out power lines. Fully guaranteed. Regularly \$275. Special factory price... **\$143.50**  
1200 Watt Plant (Item 45) same as Item 24 but with larger generator & engine—50% greater output... **\$199.50**

**FAUCET WATER HEATER**  
Instant hot water for just pennies—You just slip MASTER MECHANIC'S new Faucet Water Heater over any faucet—plug it in a wall outlet and you've got steaming hot water instantly for dishes, shaving, washing baby's bottle, etc. Simple and safe—operates on ordinary 110 v. house current—costs only 2 1/2 cents per hour for hot water. Ideal for homes, shops, cabins, trailers, etc. Easily regulated from lukewarm to full hot. Fully guaranteed. Wt. 2 lbs. (Item 408) Factory price... **\$4.95**  
Send 10c for New Catalog. Free with order. 10 day money back guarantee. Send check or M.O.  
Master Mechanic Mfg. Co., Dept. P-59, Burlington, Wis.

**\$7.95 DRAINS** cellars, cisterns, wash tubs; IRRIGATES - CIRCULATES - SPRAYS  
1,001 uses. Stainless shaft. Won't rust or clog! Use 1/8 HP motor or larger 3/4 HP for up to 3000 GPH; 450 GPH 80" high or 1500 GPH from 2 1/2" well. 1" inlet; 3/4" outlet. Coupling included free. \$7.95  
Heavy Duty Ball-Bearing Pump. Up to 7,500 GPH. 1 1/4" inlet; 1" outlet. \$12.95 Postpaid if cash with order. Money back guarantee. Also other sizes, types.  
LABAWCO PUMPS, Belle Mead 58, N.J.

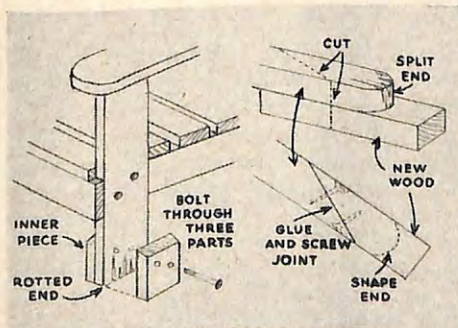

Figures 5 and 6

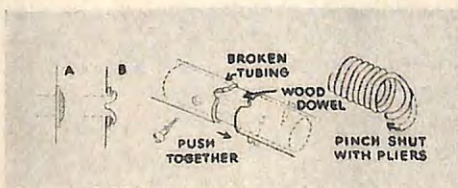

Figures 7, 8 and 9

or file a piece of dowel to a tight drive fit in both sections. Assemble the two pieces with the dowel inside, drill through the tubing to insert one or more wood screws on each side, and run any necessary holes for bolts or pivot pins through the dowel.

Stretched coil springs of the kind shown in Figure 9 are best replaced. But if only the hooked end has pulled open, such springs will serve for a time if these ends are closed with pliers.

Worn canvas should be carefully removed so that it can be used as a pattern for cutting new material. Note the direction in which it is wrapped around the wooden members; the overlap of the material usually hides the tacks. Fold the edge of the new piece over like a hem and tack through this double thickness. To replace rope webbing, use plastic coated clothesline. Such line resists weather, stays white and is easily cleaned.

## ROBERT SOUTH BARRETT

With the death of Past Grand Exalted Ruler Robert South Barrett there has been taken a most devoted Elk, a prideful, loyal American, a great humanitarian.

### AS AN ELK

Some years ago THE ELKS MAGAZINE published a memorandum by Brother Barrett bearing the title "Why I Wear An Elks Pin". It reads as follows:

"It is an emblem that tells the world that I am a member of a great Fraternity of a million American citizens who believe in God and in the destiny of the United States of America to bring happiness to its people and peace to the world. It is an emblem whose antlers are symbolic of the elk in the freedom of the forest and indicates that I too am free, free to worship God according to the dictates of my conscience, free to vote as I choose, free to speak as I choose. It is an emblem that tells that I believe in charity—the charity of kindly thoughts as well as of kindly deeds: a charity that feeds the hungry, heals the sick, straightens crippled limbs, opens blind eyes. "It is an emblem that declares my willingness to assist the youth of our land by education, guidance and protection in reaching its highest ideals.

"It is an emblem that protects womankind and is an assurance that neither harm nor tears will ever be brought to any good woman through fault of mine.

"It is an emblem that shows that I believe in brotherhood, that every man of every creed is my brother and that as I believe in the Fatherhood of God, so do I believe in the Brotherhood of Man.

"The emblem of my Fraternity! The emblem of my faith! An emblem of my country! God grant that I may always be faithful to all it represents."

### AS AN AMERICAN

In another memorandum Brother Barrett, some years ago, indicated that he regarded "American citizen" as the proudest title in all the world. He referred to his Elks card as telling him that he was the peer of emperors and kings, the ruler of his own destiny, the maker of his own fortune, as telling him that he was a citizen of a land where democracy rules, where brotherhood prevails, where tolerance holds sway.

He said that it told him that he had joined with hundreds of thousands of other Americans in the pledging of allegiance to our country and its laws, in placing the American flag first in their hearts as loyal Americans and first upon their altars as loyal Elks.

### AS A HUMANITARIAN

He was indeed one of America's great humanitarians. Largely because of his great interest in the underprivileged and his generosity, thousands of American boys and girls, victims of the cruel disease of cerebral palsy, children who, in many instances, were practically hidden by their parents because of their deformities, are now facing the world blessed with the power properly to use their physical equipment and ready to lead normal and useful lives.

For 25 years, following his mother who was one of the organizers of the institution, he served as president of that great beneficent organization, the Florence Crittenton Foundation, which has given guidance and protection to thousands of unmarried mothers practically devoid of other organizations to turn to for relief.

As an Elk, as an American, as a humanitarian Brother Barrett has left a great inspiration to all.

### A More Insidious Youth Trap

In December, 1956, THE ELKS MAGAZINE ran an editorial calling attention to the campaign of the Russian communists for a "Festival" to be held in Moscow. This they referred to as "open to all youth irrespective of their convictions, race, religious beliefs or nationality". They stated that no political, philosophical, or other tendencies would prevail at the "Festival".

A limited number of American youth attended in spite of the fact that there was considerable publicity relative to the real nature of the organization and its supporters.

This year the communists have changed the location of the "Festival"

to Vienna, the capital of a non-communist country.

This is a demonstration of the acuteness of the communists in their recent propaganda activities. Undoubtedly they expected that some of the opposition to their so-called world youth festival would be lessened if it were held outside of a communist country.

It is certain, however, that they are recognized for what they are by Roman Catholic groups of students and others from all over Austria who recently staged a mass demonstration in Vienna in protest against the "Festival".

The leader of the Conservative Party in Austria, Chancellor Charles Raal, stated that it was expected that the organization designed to protest the holding of a "Youth Festival" in Vienna would reach 30,000 students and others but

these expectations were greatly exceeded and the number of marchers really amounted to more than 50,000.

It has been very surprising, disappointing and disturbing to learn from the press that some branch of the United States Government has unofficially encouraged the participation of American students in a so-called communist "Youth Festival" this summer.

It has not been disclosed what department of the United States Government is responsible for the program to encourage the young people of America to participate in the so-called "Youth Festival" but we are compelled to hold in higher regard the Catholics of Austria than such Americans as encourage the attendance of American youth at this so-called "Festival of Youth" where ever it may be held.

Over and over again — It's the same old story...

FINALLY A FORMULA THAT REALLY WORKS

*"I was ashamed to always be so tired!"*



ALWAYS felt simply "run down". People were thinking of me as a "spoil-sport". I didn't know why until my doctor explained why I felt "tired" ... why my vigor was slipping away ... why my wife and family were beginning to think of me as a worn-out man. He told me how a vitamin-mineral deficiency in my diet could rob me of the joys of living ... and suggested that I supplement my diet with pep-building vitamins and minerals.

Well, I put off doing anything about my condition — until one day I sent for a 30-day FREE supply of high-potency Vitasafe C. F. Capsules and

began taking one Capsule a day. In a short time, I began to feel like a new man! My pep and vigor increased, I continued with the Vitasafe Plan—and I felt stronger, more energetic!

Today, no one thinks of me as a "worn-out old man". I've got pep and energy to burn, and I have fun like a fellow half my age! And you may fool! Why don't you take advantage of this sensational free offer to see for yourself whether you, too, can again feel peppy and full of life! Mail the postcard today and accept this no risk offer as I did.

Do You Wonder What Makes You

SO

DARN TIRED?



A dramatization posed by professional model.

I used to feel weak and run-down from the moment I woke up in the morning to the time I tumbled into bed at night. Believe me, doing a full day's work is hard enough even when you feel good. But trying to be a good worker, husband and father when you're "dead on your feet" would make any man a nervous wreck!

I found myself getting upset by almost everything. I was "touchy" at the office, cross and irritable with the children. I'd start arguments with my wife over the smallest things. I finally decided to see our doctor.

After examining me, the doctor explained that my tiredness and nervousness were due to a lack of important vitamins and minerals. To help correct my condition he recommended I take a good food supplement daily.

I sent away for a trial supply of Vitasafe High-Potency Capsules that I had seen advertised. In just a few weeks my energy came back, and now I feel like a new man! If you feel tired, nervous and miserable, why not send for your trial supply by mailing the postcard today?

OPEN THIS FLAP FOR SENSATIONAL FREE HIGH-POTENCY CAPSULE OFFER!



No Postage Stamp Necessary If Mailed in the United States

Postage Will be Paid by Addressee

BUSINESS REPLY MAIL FIRST CLASS PERMIT NO. 10083 — NEW YORK, N. Y.

Vitasafe Corp. 43 West 61st Street New York 23, N. Y.



**MONEY'S WORTH.** Get full value in your cigarette. Get rich, golden tobacco—and get it clear through. Lucky Strike delivers just that—plus the honest taste no man can forget.



Forest-fire lookout tower,  
Bald Mountain, Va.

**PLAY IT SAFE**—especially in wooded areas. Kill your match. Make sure your cigarette's completely out.



Indoors or outdoors,  
you enjoy the taste.



Get the genuine article

**Get the honest taste  
of a LUCKY STRIKE**